

CSD86356Q5D 同步降压 NexFET™ 电源块

1 特性

- 半桥电源块
- 25A 电流下系统效率高达 93.0%
- 工作电流高达 40A
- 高频工作（高达 1.5MHz）
- 高密度 SON 5mm × 6mm 封装
- 针对 5V 栅极驱动进行了优化
- 开关损耗较低
- 超低电感封装
- 符合 RoHS 标准
- 无卤素
- 无铅引脚镀层

2 应用

- 同步降压转换器
 - 高频应用
 - 高电流、低占空比应用
- 多相位同步降压转换器
- 负载点 (POL) 直流/直流转换器
- IMVP、VRM 和 VRD 应用

3 说明

CSD86356Q5D NexFET™ 电源块是面向同步降压应用的优化设计方案，能够以 5mm × 6mm 的小巧外形提供高电流、高效率以及高频率性能。该产品针对 5V 栅极驱动应用进行了优化，在与外部控制器/驱动器的任一 5V 栅极驱动配套使用时，可提供一套灵活的解决方案来实现高密度电源。

俯视图

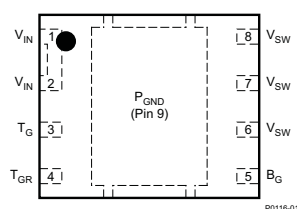

器件信息(1)

| 器件 | 介质 | 数量 | 封装 | 发货 |
|--------------|---------|------|-----------------------------|------|
| CSD86356Q5D | 13 英寸卷带 | 2500 | 5.00mm × 6.00mm SON 塑料封装 | 卷带封装 |
| CSD86356Q5DT | 7 英寸卷带 | 250 | | |

(1) 如需了解所有可用封装，请参阅数据表末尾的可订购产品附录。

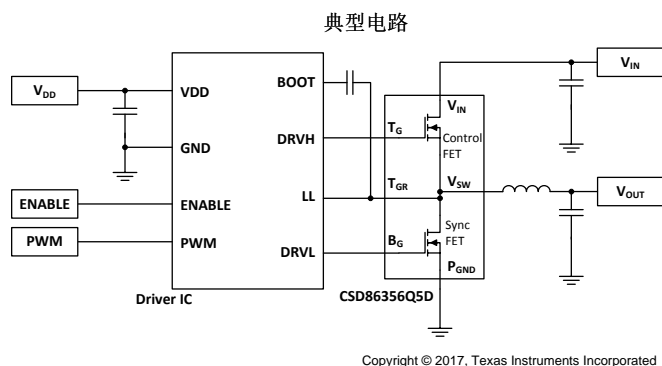

典型电源块效率与功率损耗

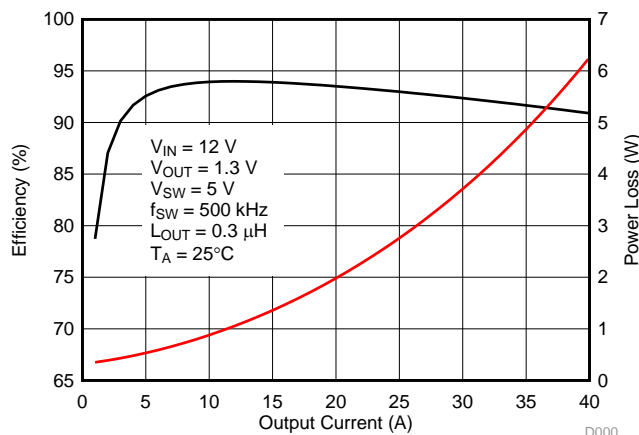

目录

| | |
|---|---|
| <p>1 特性 1</p> <p>2 应用 1</p> <p>3 说明 1</p> <p>4 修订历史记录 2</p> <p>5 Specifications 3</p> <p> 5.1 Absolute Maximum Ratings 3</p> <p> 5.2 Recommended Operating Conditions 3</p> <p> 5.3 Thermal Information 3</p> <p> 5.4 Power Block Performance 3</p> <p> 5.5 Electrical Characteristics – Q1 Control FET 4</p> <p> 5.6 Electrical Characteristics – Q2 Sync FET 5</p> <p> 5.7 Typical Power Block Device Characteristics 6</p> <p> 5.8 Typical Power Block MOSFET Characteristics 8</p> <p>6 Application and Implementation 11</p> <p> 6.1 Application Information 11</p> | <p> 6.2 Typical Application 14</p> <p>7 Layout 17</p> <p> 7.1 Recommended Schematic Overview 17</p> <p> 7.2 Recommended PCB Design Overview 18</p> <p>8 器件和文档支持 20</p> <p> 8.1 接收文档更新通知 20</p> <p> 8.2 社区资源 20</p> <p> 8.3 商标 20</p> <p> 8.4 静电放电警告 20</p> <p> 8.5 Glossary 20</p> <p>9 机械、封装和可订购信息 21</p> <p> 9.1 Q5D 封装尺寸 21</p> <p> 9.2 引脚配置 21</p> <p> 9.3 焊盘图案建议 22</p> <p> 9.4 模版建议 23</p> |
|---|---|

4 修订历史记录

| 日期 | 修订版本 | 说明 |
|------------|------|---------|
| 2018 年 3 月 | * | 最初发布版本。 |

5 Specifications

5.1 Absolute Maximum Ratings

 $T_A = 25^\circ\text{C}$ (unless otherwise noted)⁽¹⁾

| | | MIN | MAX | UNIT |
|---|--|------|-----|------------------|
| Voltage | V_{IN} to P_{GND} | -0.8 | 25 | V |
| | V_{SW} to P_{GND} | | 25 | |
| | V_{SW} to P_{GND} (10 ns) | | 27 | |
| | T_G to T_{GR} | -8 | 10 | |
| | B_G to P_{GND} | -8 | 10 | |
| Pulsed current rating, IDM ⁽²⁾ | | | 120 | A |
| Power dissipation, P_D | | | 12 | W |
| Avalanche energy, E_{AS} | Sync FET, $I_D = 88$ A, $L = 0.1$ mH | | 387 | mJ |
| | Control FET, $I_D = 45$ A, $L = 0.1$ mH | | 101 | |
| T_J and T_{STG} | Operating junction and storage temperature | -55 | 150 | $^\circ\text{C}$ |

(1) Stresses beyond those listed under Absolute Maximum Ratings may cause permanent damage to the device. These are stress ratings only, and functional operation of the device at these or any other conditions beyond those indicated is not implied. Exposure to absolute-maximum-rated conditions for extended periods may affect device reliability.

(2) Pulse duration = 50 μs . Duty cycle = 0.01.

5.2 Recommended Operating Conditions

 $T_A = 25^\circ\text{C}$ (unless otherwise noted)

| | | MIN | MAX | UNIT |
|-----------|---|-----|------|------------------|
| V_{GS} | Gate drive voltage | 4.5 | 8 | V |
| V_{IN} | Input supply voltage ⁽¹⁾ | | 22 | V |
| f_{SW} | Switching frequency $C_{BST} = 0.1$ μF (min) | | 1500 | kHz |
| | Operating current | | 40 | A |
| T_J | Operating temperature | | 125 | $^\circ\text{C}$ |
| T_{STG} | Storage temperature | | 125 | $^\circ\text{C}$ |

(1) Operating at high V_{IN} can create excessive AC voltage overshoots on the switch node (V_{SW}) during MOSFET switching transients. For reliable operation, the switch node (V_{SW}) to ground voltage must remain at or below the *Absolute Maximum Ratings*.

5.3 Thermal Information

 $T_A = 25^\circ\text{C}$ (unless otherwise noted)

| THERMAL METRIC | | MIN | MAX | UNIT |
|-----------------|---|-----|-----|---------------------------|
| $R_{\theta JA}$ | Junction-to-ambient thermal resistance (min Cu) ⁽¹⁾ | | 125 | $^\circ\text{C}/\text{W}$ |
| $R_{\theta JA}$ | Junction-to-ambient thermal resistance (max Cu) ^{(1) (2)} | | 50 | $^\circ\text{C}/\text{W}$ |
| $R_{\theta JC}$ | Junction-to-case thermal resistance (top of package) ⁽¹⁾ | | 12 | $^\circ\text{C}/\text{W}$ |
| $R_{\theta JC}$ | Junction-to-case thermal resistance (P_{GND} pin) ⁽¹⁾ | | 1.8 | $^\circ\text{C}/\text{W}$ |

(1) $R_{\theta JC}$ is determined with the device mounted on a 1-in² (6.45-cm²), 2-oz (0.071-mm) thick Cu pad on a 1.5-in \times 1.5-in (3.81-cm \times 3.81-cm), 0.06-in (1.52-mm) thick FR4 board. $R_{\theta JC}$ is specified by design while $R_{\theta JA}$ is determined by the user's board design.

(2) Device mounted on FR4 material with 1-in² (6.45-cm²) Cu.

5.4 Power Block Performance

 $T_A = 25^\circ\text{C}$ (unless otherwise noted)

| PARAMETER | TEST CONDITIONS | MIN | TYP | MAX | UNIT |
|------------|---|--|-----|-----|---------------|
| P_{LOSS} | Power loss ⁽¹⁾ | $V_{IN} = 12$ V, $V_{GS} = 5$ V, $V_{OUT} = 1.3$ V, $I_{OUT} = 25$ A, $f_{SW} = 500$ kHz, $L_{OUT} = 0.3$ μH , $T_J = 25^\circ\text{C}$ | | 2.8 | W |
| I_{QVIN} | V_{IN} quiescent current ⁽¹⁾ | T_G to $T_{GR} = 0$ V, B_G to $P_{GND} = 0$ V | | 10 | μA |

(1) Measurement made with six 10- μF (TDK C3216X5R1C106KT or equivalent) ceramic capacitors placed across V_{IN} to P_{GND} pins and using a high-current 5-V driver IC.

5.5 Electrical Characteristics – Q1 Control FET

 $T_j = 25^\circ\text{C}$ (unless otherwise noted)

| PARAMETER | | TEST CONDITIONS | MIN | TYP | MAX | UNIT |
|--------------------------------|----------------------------------|--|------|------|------|---------------|
| STATIC CHARACTERISTICS | | | | | | |
| BV_{DSS} | Drain-to-source voltage | $V_{GS} = 0\text{ V}, I_{DS} = 250\ \mu\text{A}$ | 25 | | | V |
| I_{DSS} | Drain-to-source leakage current | $V_{GS} = 0\text{ V}, V_{DS} = 20\text{ V}$ | | | 1 | μA |
| I_{GSS} | Gate-to-source leakage current | $V_{DS} = 0\text{ V}, V_{GS} = +10 / -8\text{ V}$ | | | 100 | nA |
| $V_{GS(th)}$ | Gate-to-source threshold voltage | $V_{DS} = V_{GS}, I_{DS} = 250\ \mu\text{A}$ | 0.95 | | 1.85 | V |
| $Z_{DS(on)}$ | Effective AC on-impedance | $V_{IN} = 12\text{ V}, V_{GS} = 5\text{ V}, V_{OUT} = 1.3\text{ V},$ $I_{OUT} = 20\text{ A}, f_{SW} = 500\text{ kHz},$ $L_{OUT} = 300\text{ nH}$ | | 4.5 | | m Ω |
| g_{fs} | Transconductance | $V_{DS} = 2.5\text{ V}, I_{DS} = 20\text{ A}$ | | 70 | | S |
| DYNAMIC CHARACTERISTICS | | | | | | |
| C_{ISS} | Input capacitance | $V_{GS} = 0\text{ V}, V_{DS} = 12.5\text{ V}, f = 1\text{ Mhz}$ | | 803 | 1040 | pF |
| C_{OSS} | Output capacitance | | | 548 | 712 | pF |
| C_{RSS} | Reverse transfer capacitance | | | 27 | 35 | pF |
| R_G | Series gate resistance | | | 2.1 | 4.2 | Ω |
| Q_g | Gate charge total (4.5 V) | $V_{DS} = 12.5\text{ V}, I_{DS} = 20\text{ A}$ | | 6.0 | 7.9 | nC |
| Q_{gd} | Gate charge – gate-to-drain | | | 1.3 | | nC |
| Q_{gs} | Gate charge – gate-to-source | | | 2.6 | | nC |
| $Q_{g(th)}$ | Gate charge at V_{th} | | | 1.2 | | nC |
| Q_{OSS} | Output charge | $V_{DS} = 12.5\text{ V}, V_{GS} = 0\text{ V}$ | | 10.3 | | nC |
| $t_{d(on)}$ | Turn on delay time | $V_{DS} = 12.5\text{ V}, V_{GS} = 4.5\text{ V}, I_{DS} = 20\text{ A},$ $R_G = 0\ \Omega$ | | 7 | | ns |
| t_r | Rise time | | | 26 | | ns |
| $t_{d(off)}$ | Turn off delay time | | | 12 | | ns |
| t_f | Fall time | | | 3 | | ns |
| DIODE CHARACTERISTICS | | | | | | |
| V_{SD} | Diode forward voltage | $I_{DS} = 20\text{ A}, V_{GS} = 0\text{ V}$ | 0.84 | 0.95 | | V |
| Q_{rr} | Reverse recovery charge | $V_{DD} = 12.5\text{ V}, I_F = 20\text{ A}, di/dt = 300\text{ A}/\mu\text{s}$ | | 34 | | nC |
| t_{rr} | Reverse recovery time | | | 23 | | ns |

5.6 Electrical Characteristics – Q2 Sync FET

 $T_j = 25^\circ\text{C}$ (unless otherwise noted)

| PARAMETER | | TEST CONDITIONS | MIN | TYP | MAX | UNIT |
|--------------------------------|----------------------------------|--|-----|------|------|---------------|
| STATIC CHARACTERISTICS | | | | | | |
| V_{DSS} | Drain-to-source voltage | $V_{GS} = 0\text{ V}, I_{DS} = 250\ \mu\text{A}$ | 25 | | | V |
| I_{DSS} | Drain-to-source leakage current | $V_{GS} = 0\text{ V}, V_{DS} = 20\text{ V}$ | | | 1 | μA |
| I_{GSS} | Gate-to-source leakage current | $V_{DS} = 0\text{ V}, V_{GS} = +10 / -8\text{ V}$ | | | 100 | nA |
| $V_{GS(th)}$ | Gate-to-source threshold voltage | $V_{DS} = V_{GS}, I_{DS} = 250\ \mu\text{A}$ | 0.9 | | 1.5 | V |
| $Z_{DS(on)}$ | Effective AC on-impedance | $V_{IN} = 12\text{ V}, V_{GS} = 5\text{ V}, V_{OUT} = 1.3\text{ V},$ $I_{OUT} = 20\text{ A}, f_{SW} = 500\text{ kHz},$ $L_{OUT} = 300\text{ nH}$ | | 0.8 | | m Ω |
| g_{fs} | Transconductance | $V_{DS} = 2.5\text{ V}, I_{DS} = 20\text{ A}$ | | 106 | | S |
| DYNAMIC CHARACTERISTICS | | | | | | |
| C_{ISS} | Input capacitance | $V_{GS} = 0\text{ V}, V_{DS} = 12.5\text{ V}, f = 1\text{ Mhz}$ | | 1930 | 2510 | pF |
| C_{OSS} | Output capacitance | | | 1350 | 1760 | pF |
| C_{RSS} | Reverse transfer capacitance | | | 64 | 83 | pF |
| R_G | Series gate resistance | | | 0.8 | 1.6 | Ω |
| Q_g | Gate charge total (4.5 V) | $V_{DS} = 12.5\text{ V}, I_{DS} = 20\text{ A}$ | | 14.8 | 19.3 | nC |
| Q_{gd} | Gate charge – gate-to-drain | | | 3.3 | | nC |
| Q_{gs} | Gate charge – gate-to-source | | | 5.2 | | nC |
| $Q_{g(th)}$ | Gate charge at V_{th} | | | 2.5 | | nC |
| Q_{OSS} | Output charge | $V_{DS} = 12.5\text{ V}, V_{GS} = 0\text{ V}$ | | 24.9 | | nC |
| $t_{d(on)}$ | Turn on delay time | $V_{DS} = 12.5\text{ V}, V_{GS} = 4.5\text{ V}, I_{DS} = 20\text{ A},$ $R_G = 0\ \Omega$ | | 10 | | ns |
| t_r | Rise time | | | 25 | | ns |
| $t_{d(off)}$ | Turn off delay time | | | 18 | | ns |
| t_f | Fall time | | | 4 | | ns |
| DIODE CHARACTERISTICS | | | | | | |
| V_{SD} | Diode forward voltage | $I_{DS} = 20\text{ A}, V_{GS} = 0\text{ V}$ | | 0.79 | 0.95 | V |
| Q_{rr} | Reverse recovery charge | $V_{DS} = 12.5\text{ V}, I_F = 20\text{ A}, di/dt = 300\text{ A}/\mu\text{s}$ | | 60 | | nC |
| t_{rr} | Reverse recovery time | | | 30 | | ns |

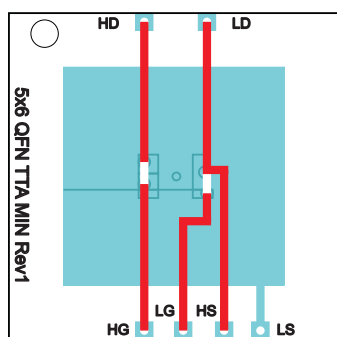

M0189-01

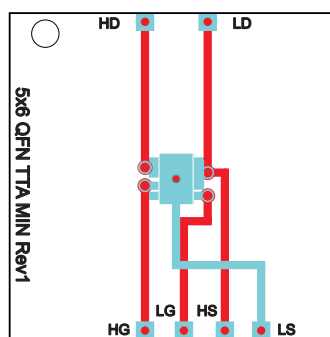

M0190-01

5.7 Typical Power Block Device Characteristics

$T_J = 125^\circ\text{C}$, unless stated otherwise. The typical power block system characteristic curves and 图 3 are based on measurements made on a PCB design with dimensions of 4 in (W) × 3.5 in (L) × 0.062 in (H) and 6 copper layers of 1-oz copper thickness. See [Application and Implementation](#) section for detailed explanation.

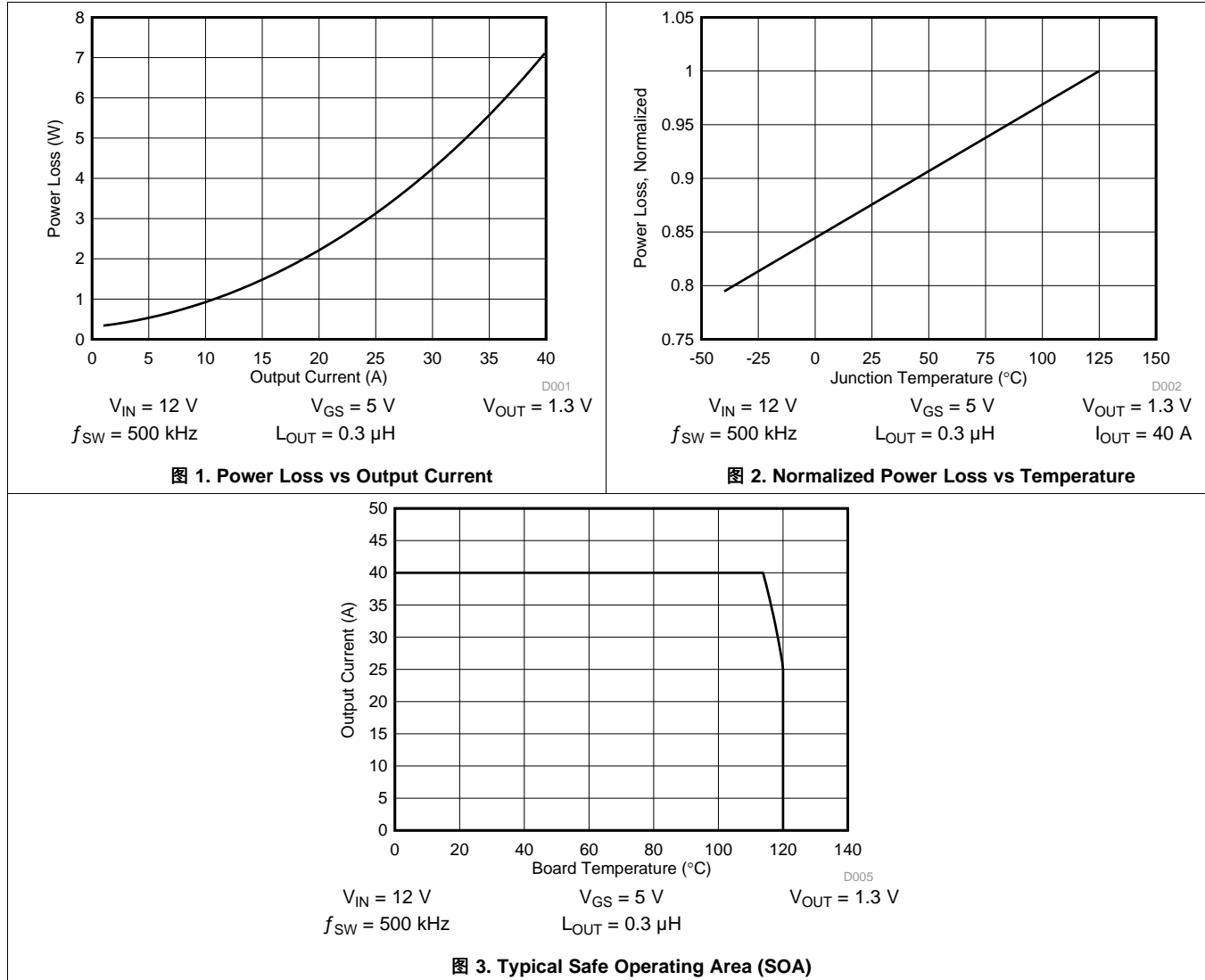

Typical Power Block Device Characteristics (接下页)

$T_J = 125^\circ\text{C}$, unless stated otherwise. The typical power block system characteristic curves and 图 3 are based on measurements made on a PCB design with dimensions of 4 in (W) × 3.5 in (L) × 0.062 in (H) and 6 copper layers of 1-oz copper thickness. See [Application and Implementation](#) section for detailed explanation.

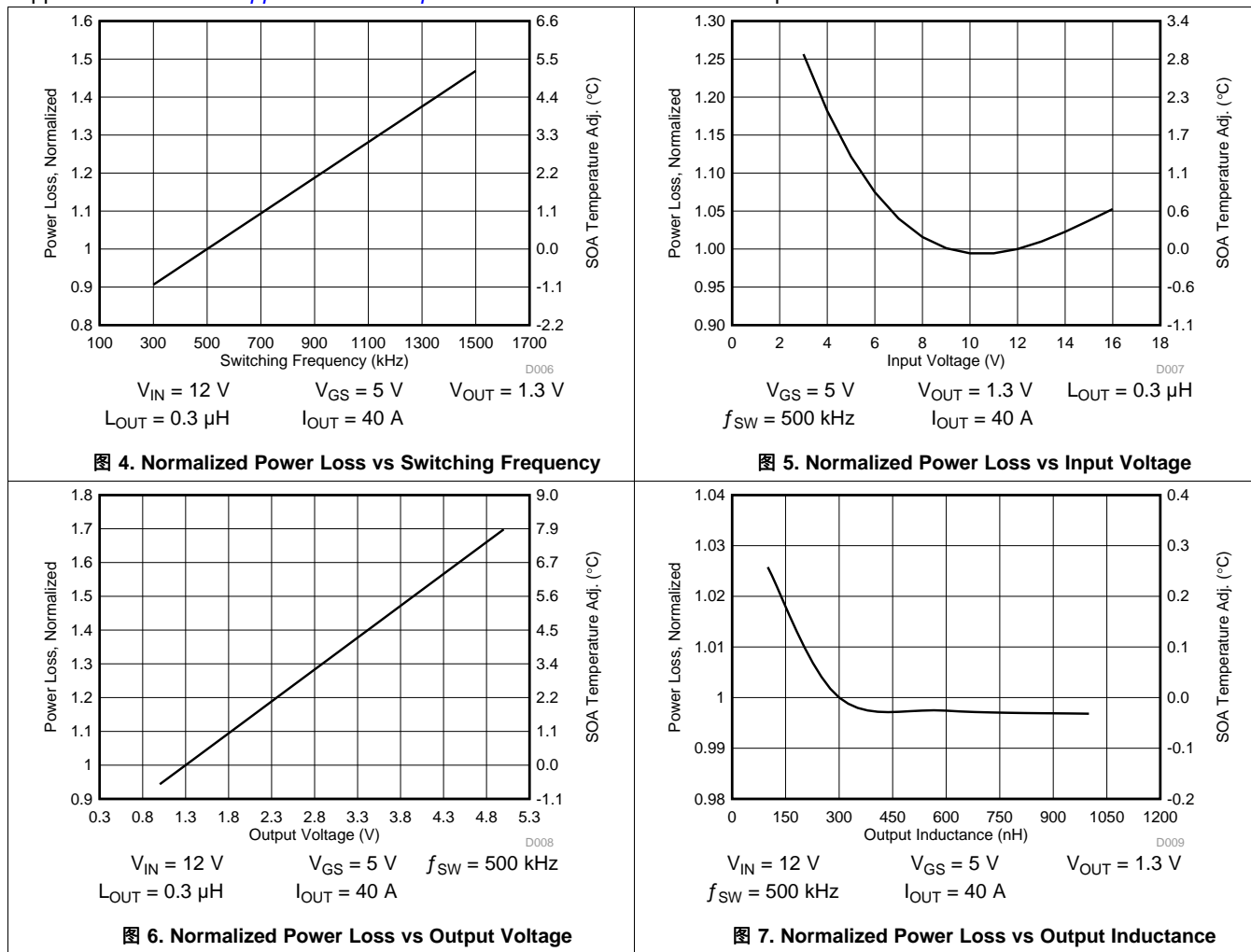

5.8 Typical Power Block MOSFET Characteristics

$T_A = 25^\circ\text{C}$, unless stated otherwise.



图 8. Control MOSFET Saturation



图 9. Sync MOSFET Saturation

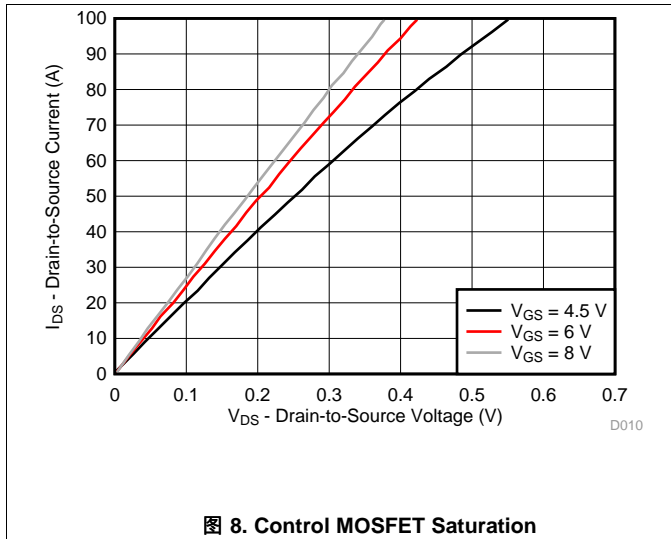

图 10. Control MOSFET Transfer

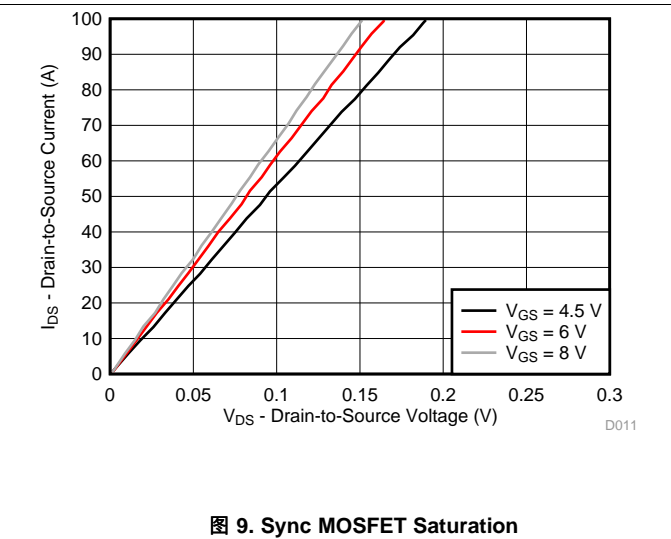

图 11. Sync MOSFET Transfer

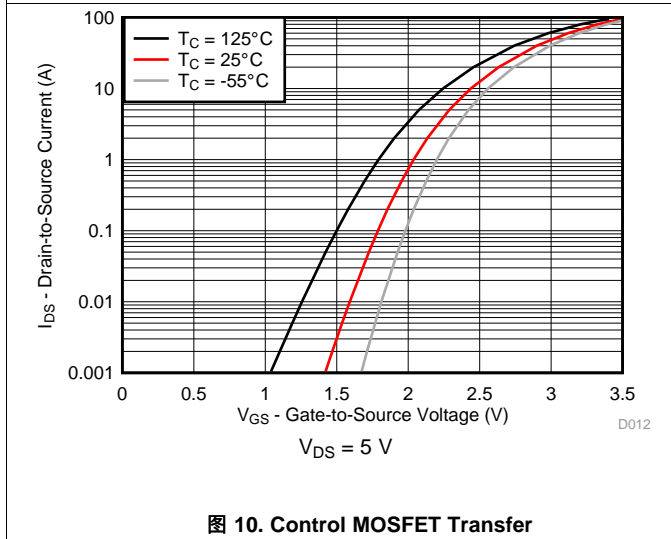

图 12. Control MOSFET Gate Charge

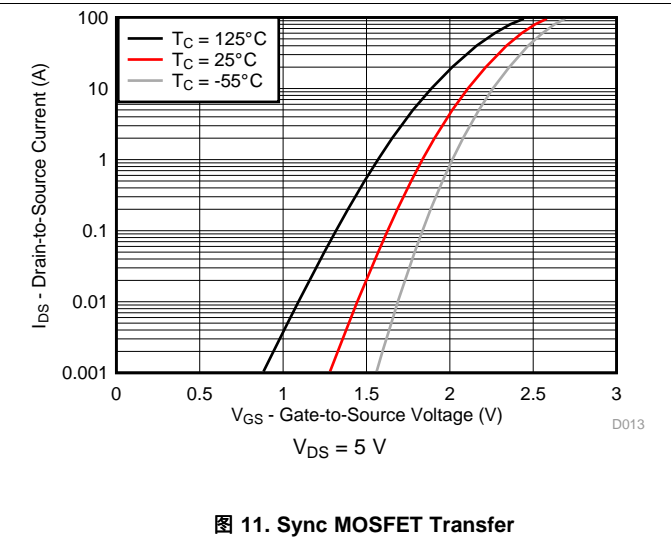

图 13. Sync MOSFET Gate Charge

Typical Power Block MOSFET Characteristics (接下页)

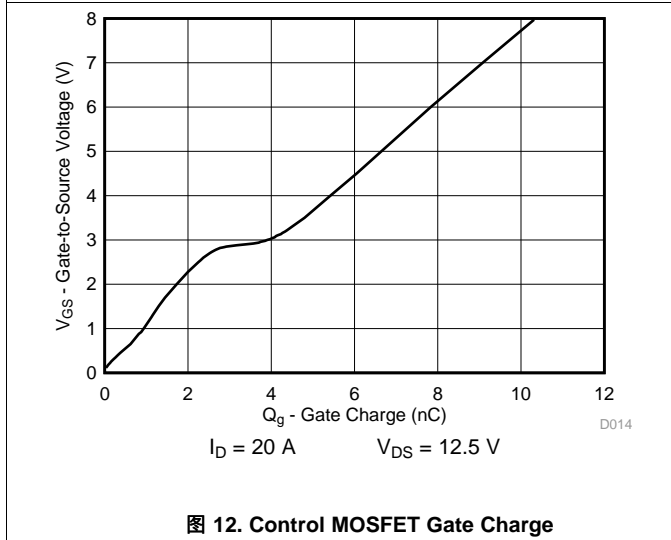
$T_A = 25^\circ\text{C}$, unless stated otherwise.

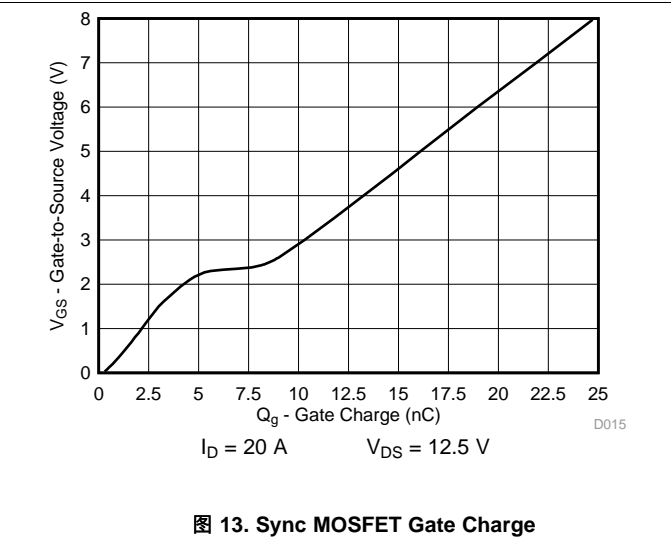

图 14. Control MOSFET Capacitance



图 15. Sync MOSFET Capacitance

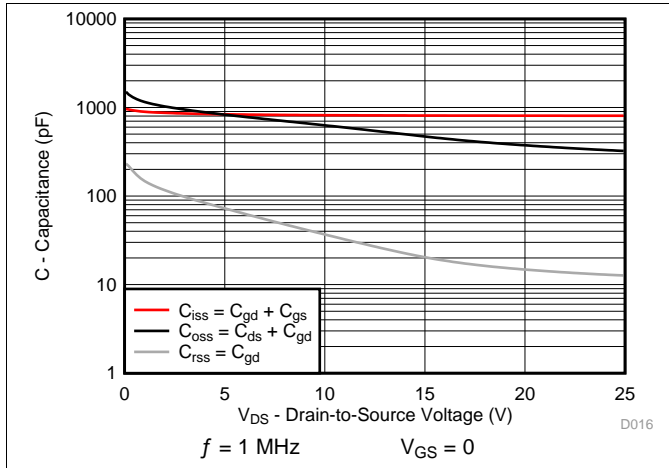

图 16. Control MOSFET $V_{GS(th)}$

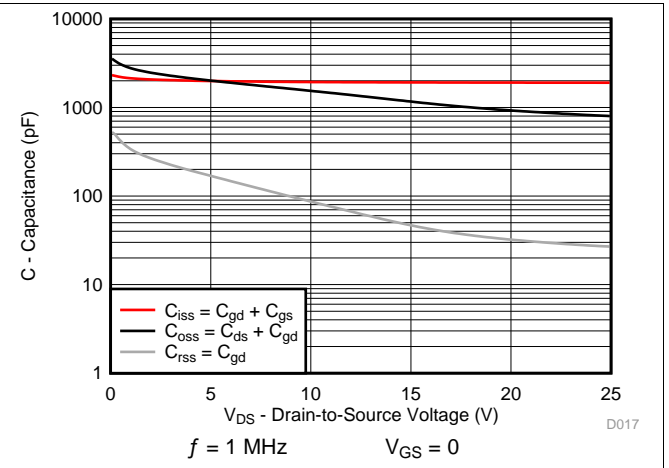

图 17. Sync MOSFET $V_{GS(th)}$

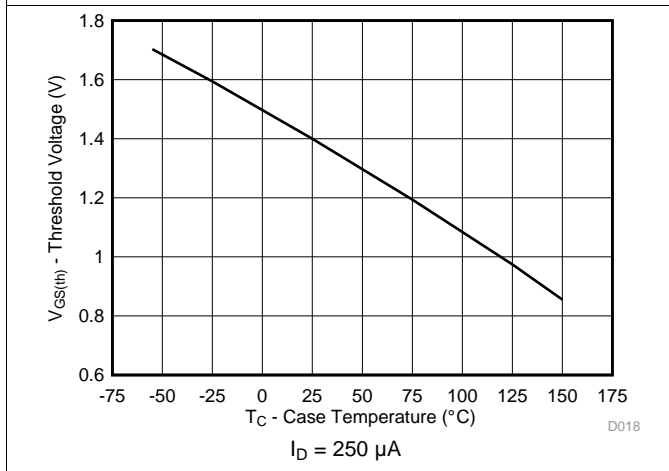

图 18. Control MOSFET $R_{DS(on)}$ vs V_{GS}

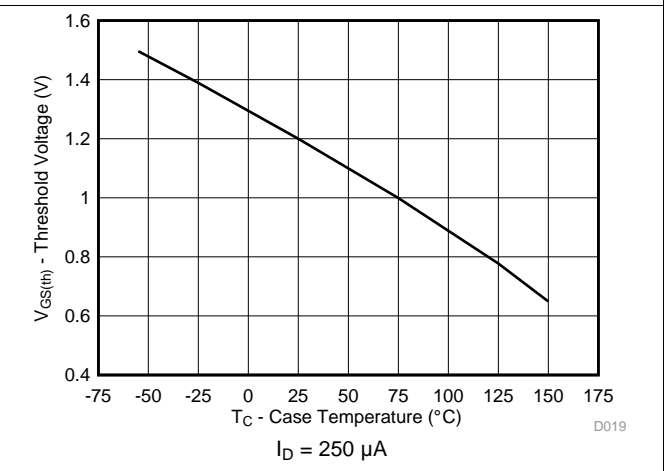

图 19. Sync MOSFET $R_{DS(on)}$ vs V_{GS}

Typical Power Block MOSFET Characteristics (接下页)

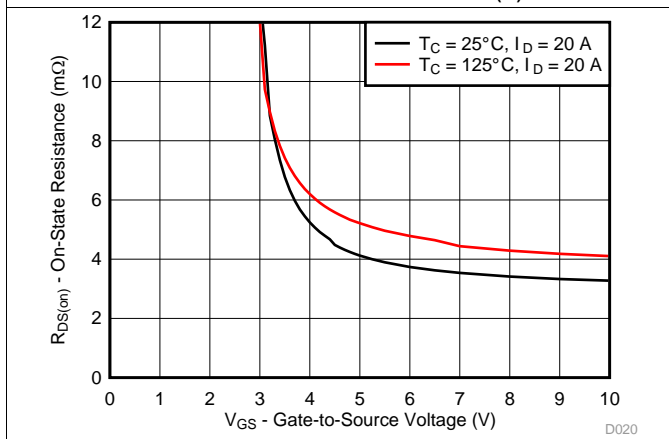
$T_A = 25^\circ\text{C}$, unless stated otherwise.

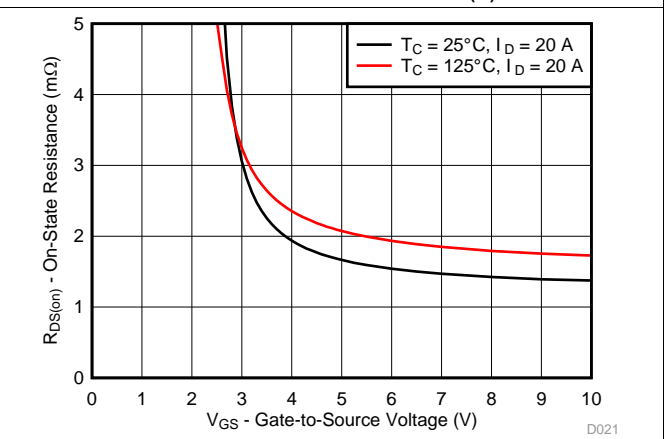
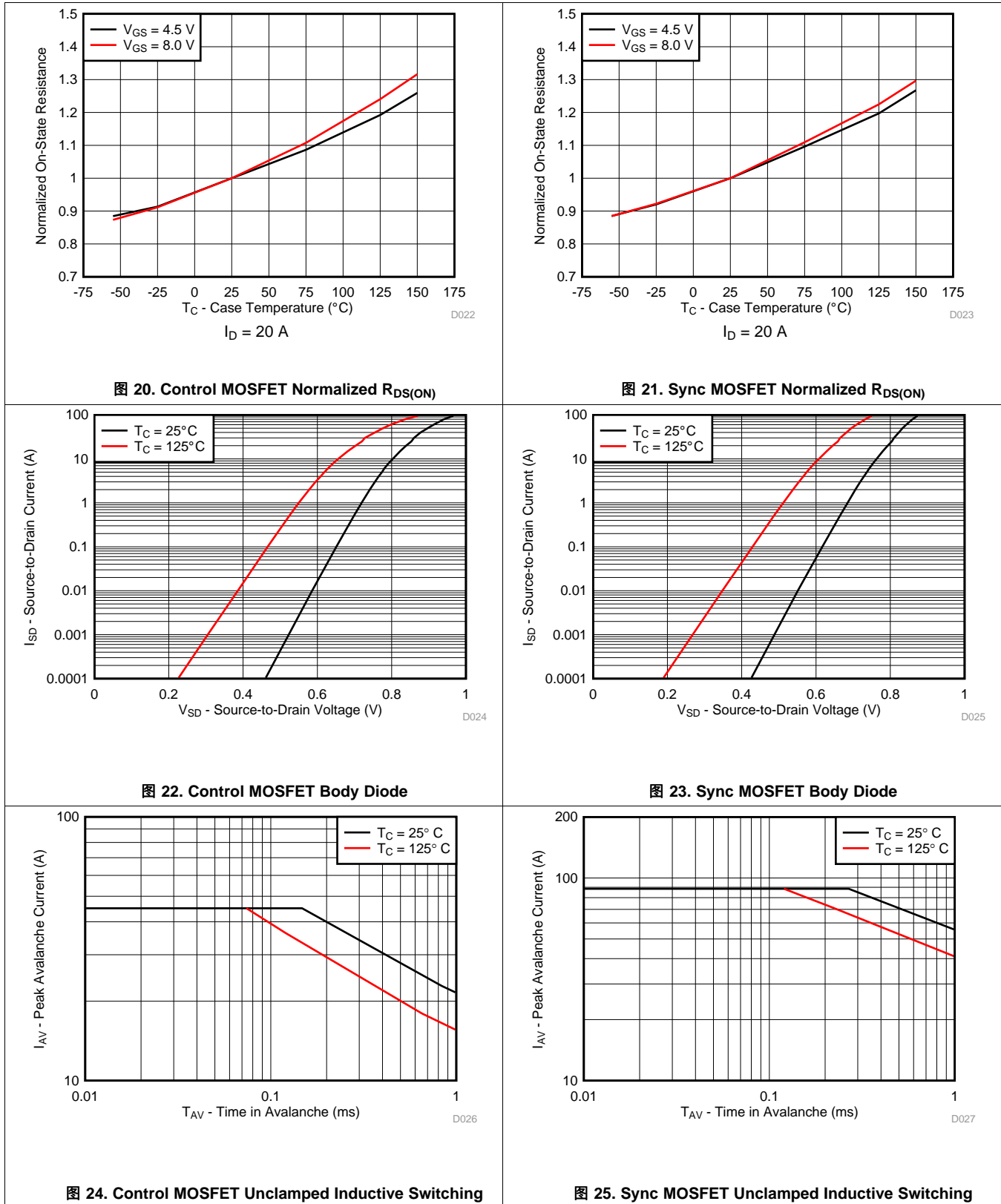

6 Application and Implementation

注

Information in the following applications sections is not part of the TI component specification, and TI does not warrant its accuracy or completeness. TI's customers are responsible for determining suitability of components for their purposes. Customers should validate and test their design implementation to confirm system functionality.

6.1 Application Information

The CSD86356Q5D NexFET power block is an optimized design for synchronous buck applications using 5-V gate drive. The control FET and sync FET silicon are parametrically tuned to yield the lowest power loss and highest system efficiency. As a result, a new rating method is needed which is tailored towards a more systems-centric environment. System-level performance curves such as power loss, Safe Operating Area (SOA), and normalized graphs allow engineers to predict the product performance in the actual application.

6.1.1 Equivalent System Performance

Many of today's high-performance computing systems require low-power consumption in an effort to reduce system operating temperatures and improve overall system efficiency. This has created a major emphasis on improving the conversion efficiency of today's synchronous buck topology. In particular, there has been an emphasis in improving the performance of the critical power semiconductor in the power stage of this application (see 图 26). As such, optimization of the power semiconductors in these applications, needs to go beyond simply reducing $R_{DS(ON)}$.



图 26. Synchronous Buck Topology

Application Information (接下页)

The CSD86356Q5D is part of TI's power block product family which is a highly optimized product for use in a synchronous buck topology requiring high current, high efficiency, and high frequency. It incorporates TI's latest generation silicon which has been optimized for switching performance, as well as minimizing losses associated with Q_{GD} , Q_{GS} , and Q_{RR} . Furthermore, TI's patented packaging technology has minimized losses by nearly eliminating parasitic elements between the control FET and sync FET connections (see 图 27). A key challenge solved by TI's patented packaging technology is the system-level impact of Common Source Inductance (CSI). CSI greatly impedes the switching characteristics of any MOSFET which in turn increases switching losses and reduces system efficiency. As a result, the effects of CSI need to be considered during the MOSFET selection process. In addition, standard MOSFET switching loss equations used to predict system efficiency need to be modified in order to account for the effects of CSI. Further details behind the effects of CSI and modification of switching loss equations are outlined in TI's Application Note [Power Loss Calculation With Common Source Inductance Consideration for Synchronous Buck Converters](#) (SLPA009).

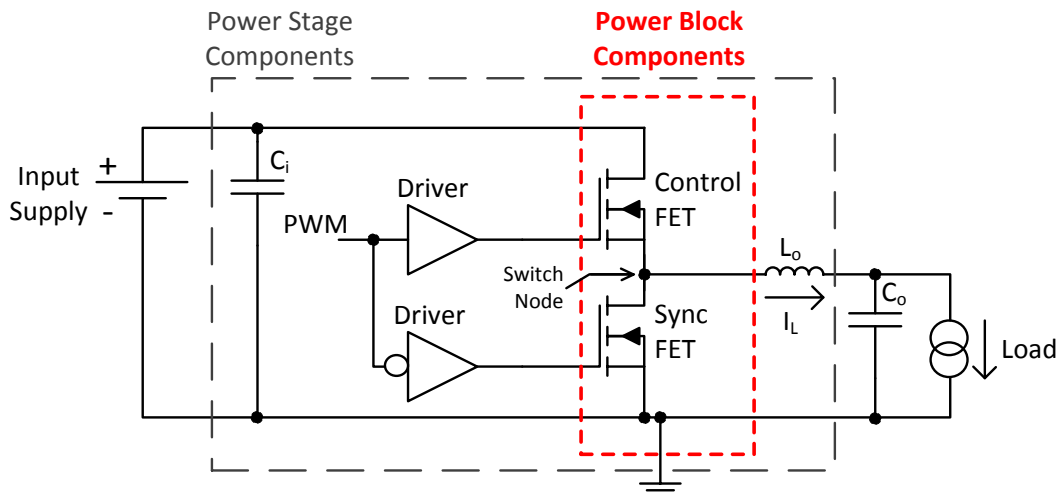

图 27. Elimination of Common Source Inductance

The combination of TI's latest generation silicon and optimized packaging technology has created a benchmarking solution that outperforms industry standard MOSFET chipsets of similar $R_{DS(ON)}$ and MOSFET chipsets with lower $R_{DS(ON)}$. 图 28 and 图 29 compare the efficiency and power loss performance of the CSD86356Q5D versus industry standard MOSFET chipsets commonly used in this type of application. This comparison purely focuses on the efficiency and generated loss of the power semiconductors only. The performance of CSD86356Q5D clearly highlights the importance of considering the Effective AC On-Impedance ($Z_{DS(ON)}$) during the MOSFET selection process of any new design. Simply normalizing to traditional MOSFET $R_{DS(ON)}$ specifications is not an indicator of the actual in-circuit performance when using TI's Power Block technology.

Application Information (接下页)

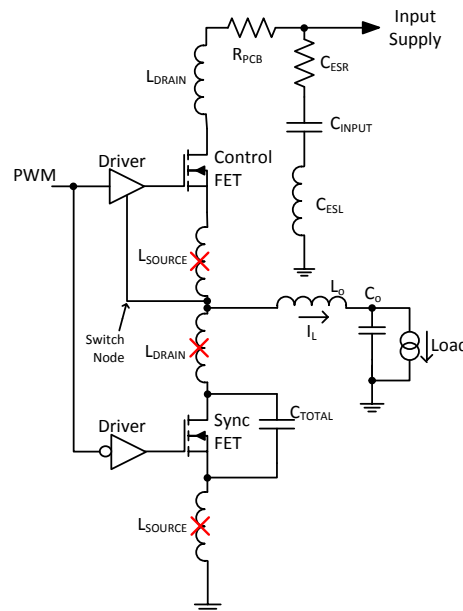
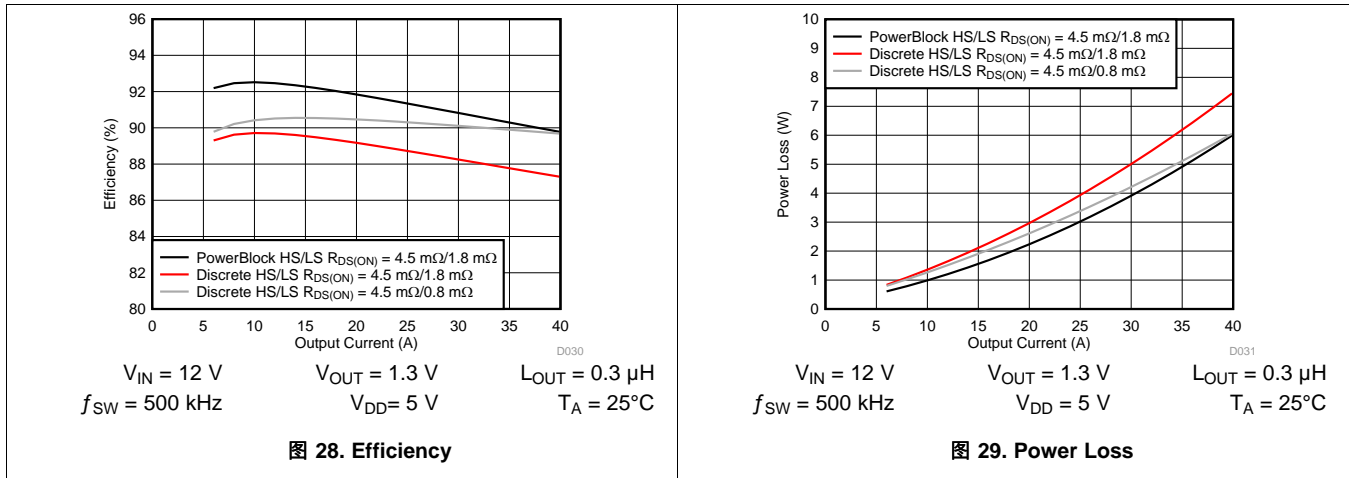

Comparison of $R_{DS(ON)}$ vs $Z_{DS(ON)}$ compares the traditional DC measured $R_{DS(ON)}$ of CSD86356Q5D versus its $Z_{DS(ON)}$. This comparison takes into account the improved efficiency associated with TI's patented packaging technology. As such, when comparing TI's Power Block products to individually packaged discrete MOSFETs or dual MOSFETs in a standard package, the in-circuit switching performance of the solution must be considered. In this example, individually packaged discrete MOSFETs or dual MOSFETs in a standard package would need to have DC measured $R_{DS(ON)}$ values that are equivalent to CSD86356Q5D's $Z_{DS(ON)}$ value in order to have the same efficiency performance at full load. Mid to light-load efficiency will still be lower with individually packaged discrete MOSFETs or dual MOSFETs in a standard package.

6.1.1.1 Comparison of $R_{DS(ON)}$ vs $Z_{DS(ON)}$

| PARAMETER | HS | | LS | | UNIT |
|---|-----|-----|-----|-----|------|
| | TYP | MAX | TYP | MAX | |
| Effective AC on-impedance $Z_{DS(ON)}$ ($V_{GS} = 5 V$) | 4.5 | — | 0.8 | — | mΩ |
| DC measured $R_{DS(ON)}$ ($V_{GS} = 4.5 V$) | 4.5 | 5.6 | 1.8 | 2.2 | mΩ |

6.1.2 Power Loss Curves

MOSFET centric parameters such as $R_{DS(ON)}$ and Q_{gd} are needed to estimate the loss generated by the devices. In an effort to simplify the design process for engineers, Texas Instruments has provided measured power loss performance curves. 图 1 plots the power loss of the CSD86356Q5D as a function of load current. This curve is measured by configuring and running the CSD86356Q5D as it would be in the final application (see 图 30). The measured power loss is the CSD86356Q5D loss and consists of both input conversion loss and gate drive loss. 公式 1 is used to generate the power loss curve.

$$(V_{IN} \times I_{IN}) + (V_{DD} \times I_{DD}) - (V_{SW_AVG} \times I_{OUT}) = \text{Power loss} \tag{1}$$

The power loss curve in 图 1 is measured at the maximum recommended junction temperatures of 125°C under isothermal test conditions.

6.1.3 Safe Operating Area (SOA) Curves

The SOA curves in the CSD86356Q5D data sheet provides guidance on the temperature boundaries within an operating system by incorporating the thermal resistance and system power loss. 图 3 outline the temperature and airflow conditions required for a given load current. The area under the curve dictates the safe operating area. All the curves are based on measurements made on a PCB design with dimensions of 4 in (W) × 3.5 in (L) × 0.062 in (T) and 6 copper layers of 1-oz copper thickness.

6.1.4 Normalized Curves

The normalized curves in the CSD86356Q5D data sheet provides guidance on the power loss and SOA adjustments based on their application specific needs. These curves show how the power loss and SOA boundaries will adjust for a given set of system conditions. The primary Y-axis is the normalized change in power loss and the secondary Y-axis is the change in system temperature required in order to comply with the SOA curve. The change in power loss is a multiplier for the power loss curve and the change in temperature is subtracted from the SOA curve.

6.2 Typical Application

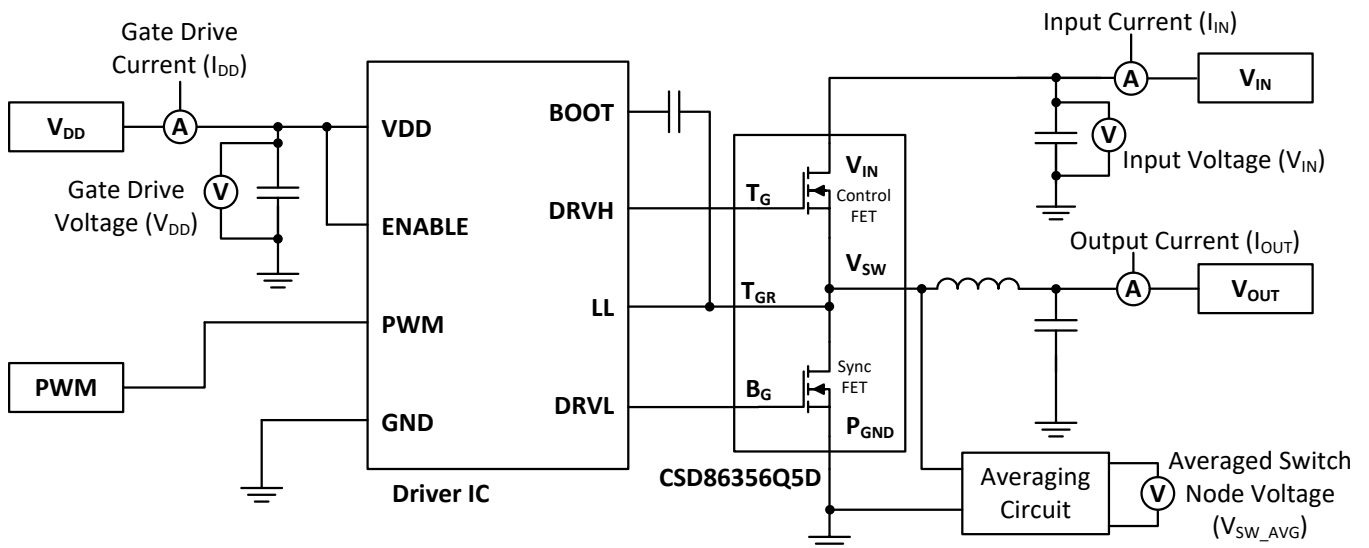

Copyright © 2018, Texas Instruments Incorporated

图 30. Typical Application

Typical Application (接下页)

6.2.1 Design Example: Calculating Power Loss and SOA

The user can estimate product loss and SOA boundaries by arithmetic means (see [Operating Conditions](#)). Though the power loss and SOA curves in this data sheet are taken for a specific set of test conditions, the following procedure will outline the steps the user should take to predict product performance for any set of system conditions.

6.2.2 Operating Conditions

- Output current = 35 A
- Input voltage = 5 V
- Output voltage = 2 V
- Switching frequency = 950 kHz
- Inductor = 0.3 μ H

6.2.2.1 Calculating Power Loss

- Power loss at 35 A = 5.57 W (图 1)
- Normalized power loss for input voltage \approx 1.12 (图 5)
- Normalized power loss for output voltage \approx 1.13 (图 6)
- Normalized power loss for switching frequency \approx 1.21 (图 4)
- Normalized power loss for output inductor \approx 1 (图 7)
- **Final calculated power loss = 5.57 W \times 1.12 \times 1.13 \times 1.21 \times 1 \approx 8.5 W**

6.2.2.2 Calculating SOA Adjustments

- SOA adjustment for input voltage \approx 1.37°C (图 5)
- SOA adjustment for output voltage \approx 1.48°C (图 6)
- SOA adjustment for switching frequency \approx 2.34°C (图 4)
- SOA adjustment for output inductor \approx 0.03°C (图 7)
- **Final calculated SOA adjustment = 1.37 + 1.48 + 2.34 + 0.03 \approx 5.2°C**

In the previous design example, the estimated power loss of the CSD58915Q5D would increase to 8.5 W. In addition, the maximum allowable board and/or ambient temperature would have to decrease by 5.2°C. 图 31 graphically shows how the SOA curve would be adjusted accordingly.

1. Start by drawing a horizontal line from the application current to the SOA curve.
2. Draw a vertical line from the SOA curve intercept down to the board/ambient temperature.
3. Adjust the SOA board/ambient temperature by subtracting the temperature adjustment value.

Typical Application (接下页)

In the design example, the SOA temperature adjustment yields a reduction in allowable board/ambient temperature of 5.2°C. In the event the adjustment value is a negative number, subtracting the negative number would yield an increase in allowable board/ambient temperature.



图 31. Power Block SOA

7 Layout

7.1 Recommended Schematic Overview

There are several critical components that must be used in conjunction with this power block device. 图 32 shows a portion of a schematic with the critical components needed for proper operation.

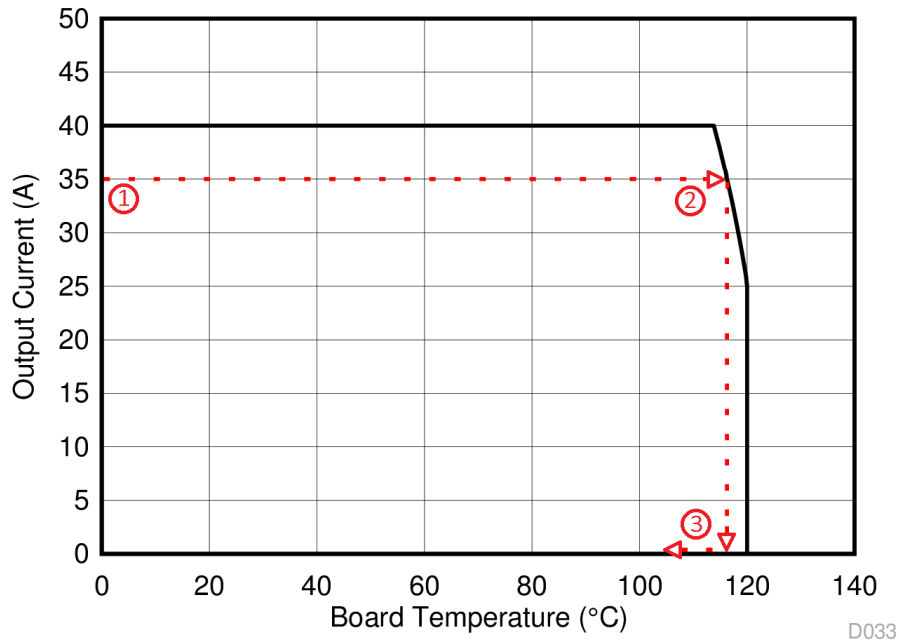
- C22: Bypass capacitor for V_{IN} to help with ringing reduction (recommend 3.3-nF, 0402, 50-V ceramic capacitor)
- C20: Bootstrap capacitor
- C21: Bypass capacitor for V_{DD}
- C7-C14: Bypass capacitors for V_{IN} (minimum of 40 μ F)
- C15: Electrolytic capacitor for V_{IN}
- R14, R16: Place holder for gate resistor (optional)
- R15: Place holder for bootstrap resistor (optional)
- R17, C16: Place holder for snubber (optional)

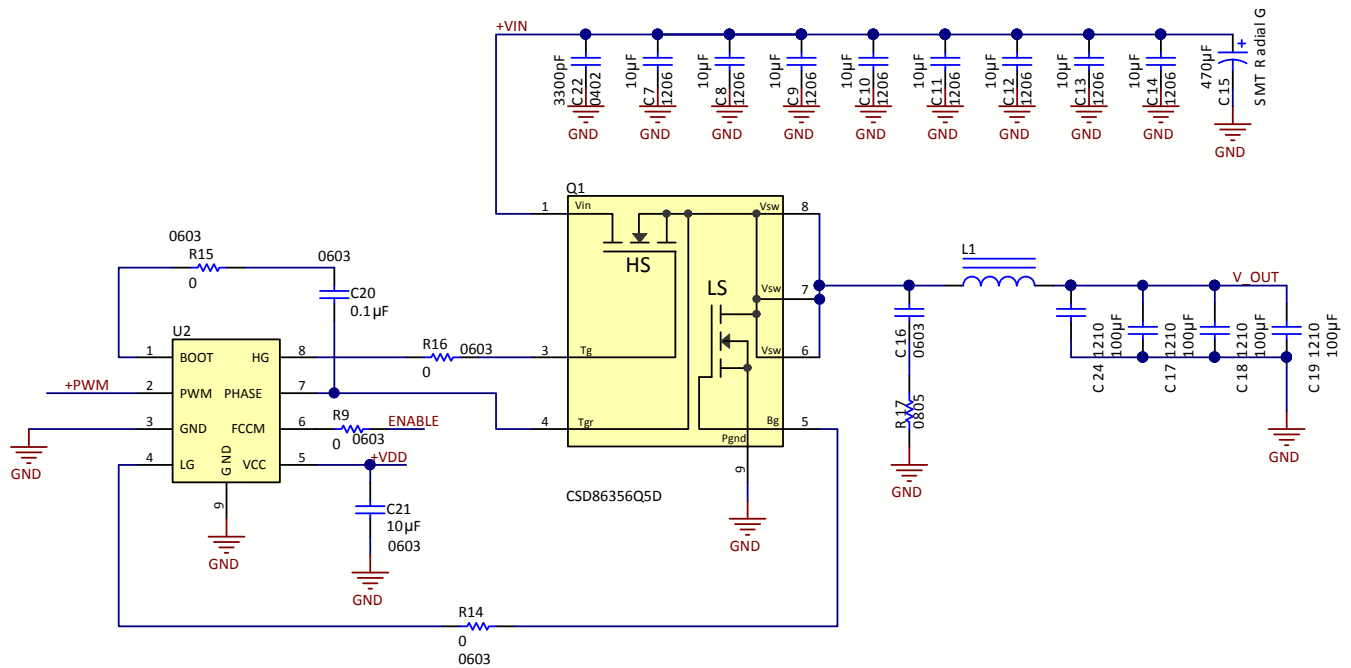

Copyright © 2017, Texas Instruments Incorporated

图 32. Recommended Schematic

7.2 Recommended PCB Design Overview

There are two key system-level parameters that can be addressed with a proper PCB design: electrical and thermal performance. Properly optimizing the PCB layout yields maximum performance in both areas. A brief description on how to address each parameter follows.

7.2.1 Electrical Performance

The power block has the ability to switch at voltage rates greater than 10 kV/μs. Special care must be taken with the PCB layout design and placement of the input capacitors, inductor, driver IC and output capacitors.

- The placement of the input capacitors relative to the power block's VIN and PGND pins should have the highest priority during the component placement routine. It is critical to minimize these node lengths. As such, ceramic input capacitors need to be placed as close as possible to the VIN and PGND pins (see [图 33](#) and [图 34](#)). It is recommended that one 3.3-nF (or similar), 0402, 50-V ceramic capacitor be placed on the top side of the board as close as possible to VIN and PGND pins. In addition, a minimum of 40 μF of bulk ceramic capacitance should be placed as close as possible to the power block in a design. For high-density design, some of these ceramic capacitors can be placed on the bottom layer of PCB with appropriate number of vias interconnecting both layers.
- The driver IC should be placed relatively close to the power block gate pins. T_G and B_G should connect to the outputs of the driver IC. The T_{GR} pin serves as the return path of the high-side gate drive circuitry and should be connected to the phase pin of the IC (sometimes called LX, LL, SW, PH, etc.). The bootstrap capacitor for the driver IC will also connect to this pin.
- The switching node of the output inductor should be placed relatively close to the power block VSW pins. Minimizing the node length between these two components will reduce the PCB conduction losses and actually reduce the switching noise level. In the event the switch node waveform exhibits ringing that reaches undesirable levels, the use of a boost resistor or RC snubber can be an effective way to easily reduce the peak ring level. The recommended boost resistor value will range between 1.0 Ω to 4.7 Ω depending on the output characteristics of driver IC used in conjunction with the power block. The RC snubber values can range from 0.5 Ω to 2.2 Ω for the R and 330 pF to 2200 pF for the C. Please refer to [Snubber Circuits: Theory, Design and Application](#) (SLUP100) for more details on how to properly tune the RC snubber values. The RC snubber should be placed as close as possible to the VSW node and PGND (see [图 33](#) and [图 34](#)).⁽¹⁾

(1) Keong W. Kam, David Pommerenke, "EMI Analysis Methods for Synchronous Buck Converter EMI Root Cause Analysis", University of Missouri – Rolla

Recommended PCB Design Overview (接下页)

7.2.2 Thermal Performance

The power block has the ability to utilize the GND planes as the primary thermal path. As such, the use of thermal vias is an effective way to pull away heat from the device and into the system board. Concerns of solder voids and manufacturability problems can be addressed by the use of three basic tactics to minimize the amount of solder attach that will wick down the via barrel:

- Intentionally space out the vias from each other to avoid a cluster of holes in a given area.
- Use the smallest drill size allowed in your design. The examples in 图 33 and 图 34 use vias with a 10-mil drill hole and a 16-mil capture pad.
- Tent the opposite side of the via with solder-mask.

In the end, the number and drill size of the thermal vias should align with the end user's PCB design rules and manufacturing capabilities.



图 33. Recommended PCB Layout (Top Down View)



图 34. Recommended PCB Layout (Bottom View) ⁽²⁾

(2) The yellow box on 图 34 signifies an approximate location of the power block on the upper layer.

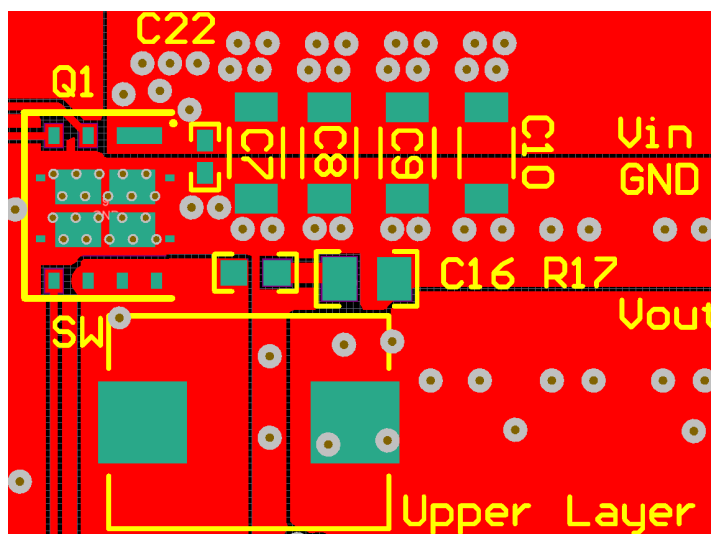
8 器件和文档支持

8.1 接收文档更新通知

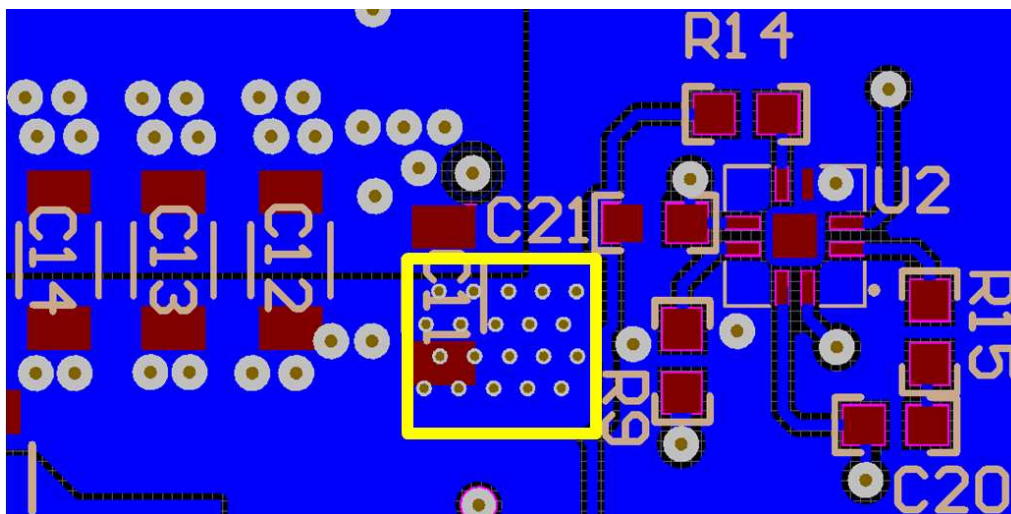
要接收文档更新通知，请导航至 TI.com.cn 上的器件产品文件夹。请单击右上角的 **提醒我** 进行注册，即可每周接收产品信息更改摘要。有关更改的详细信息，请查看任何已修订文档中包含的修订历史记录。

8.2 社区资源

下列链接提供到 TI 社区资源的连接。链接的内容由各个分销商“按照原样”提供。这些内容并不构成 TI 技术规范，并且不一定反映 TI 的观点；请参阅 TI 的 [《使用条款》](#)。

TI E2E™ 在线社区 [TI 的工程师对工程师 \(E2E\) 社区](#)。此社区的创建目的在于促进工程师之间的协作。在 e2e.ti.com 中，您可以咨询问题、分享知识、拓展思路并与同行工程师一道帮助解决问题。

设计支持 [TI 参考设计支持](#) 可帮助您快速查找有帮助的 E2E 论坛、设计支持工具以及技术支持的联系信息。

8.3 商标

NexFET, E2E are trademarks of Texas Instruments.
All other trademarks are the property of their respective owners.

8.4 静电放电警告



这些装置包含有限的内置 ESD 保护。存储或装卸时，应将导线一起截短或将装置放置于导电泡棉中，以防止 MOS 门极遭受静电损伤。

8.5 Glossary

[SLYZ022](#) — *TI Glossary*.

This glossary lists and explains terms, acronyms, and definitions.

9 机械、封装和可订购信息

以下页面包含机械、封装和可订购信息。这些信息是指定器件的最新可用数据。数据如有变更，恕不另行通知，且不会对此文档进行修订。如需获取此数据表的浏览器版本，请参阅左侧的导航栏。

9.1 Q5D 封装尺寸

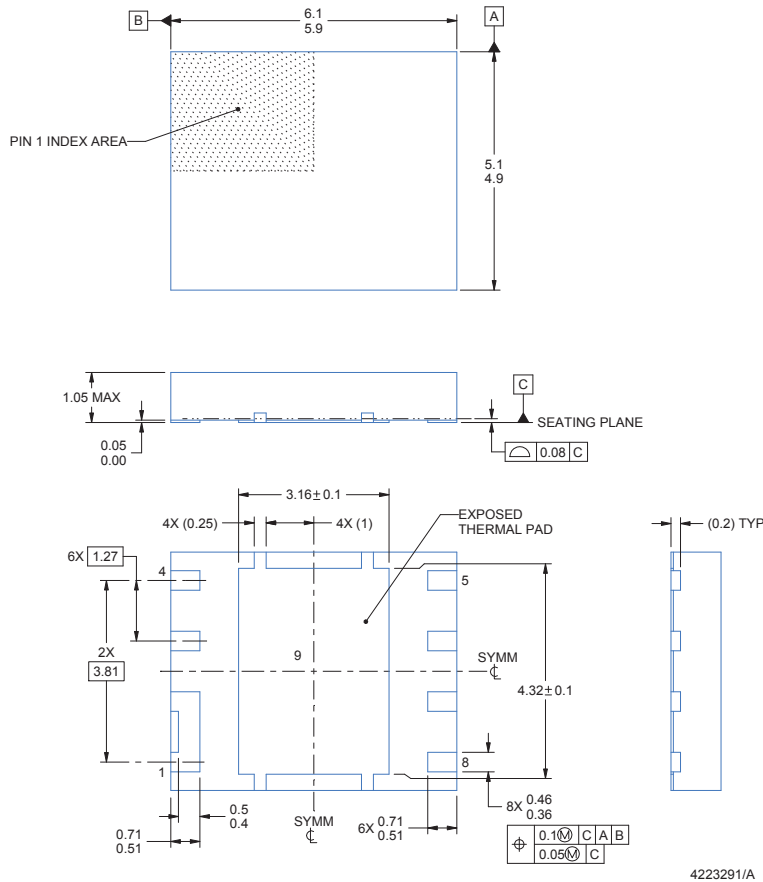

1. 所有线性尺寸的单位均为毫米。括号中的任何尺寸仅供参考。尺寸和公差值符合 ASME Y14.5M 标准。
2. 本图如有变更，恕不另行通知。
3. 封装散热焊盘必须焊接在印刷电路板上，以实现最佳的散热和机械性能。

9.2 引脚配置

| 位置 | 名称 |
|------|------------------|
| 引脚 1 | V _{IN} |
| 引脚 2 | V _{IN} |
| 引脚 3 | T _G |
| 引脚 4 | T _{GR} |
| 引脚 5 | B _G |
| 引脚 6 | V _{SW} |
| 引脚 7 | V _{SW} |
| 引脚 8 | V _{SW} |
| 引脚 9 | P _{GND} |

9.3 焊盘图案建议

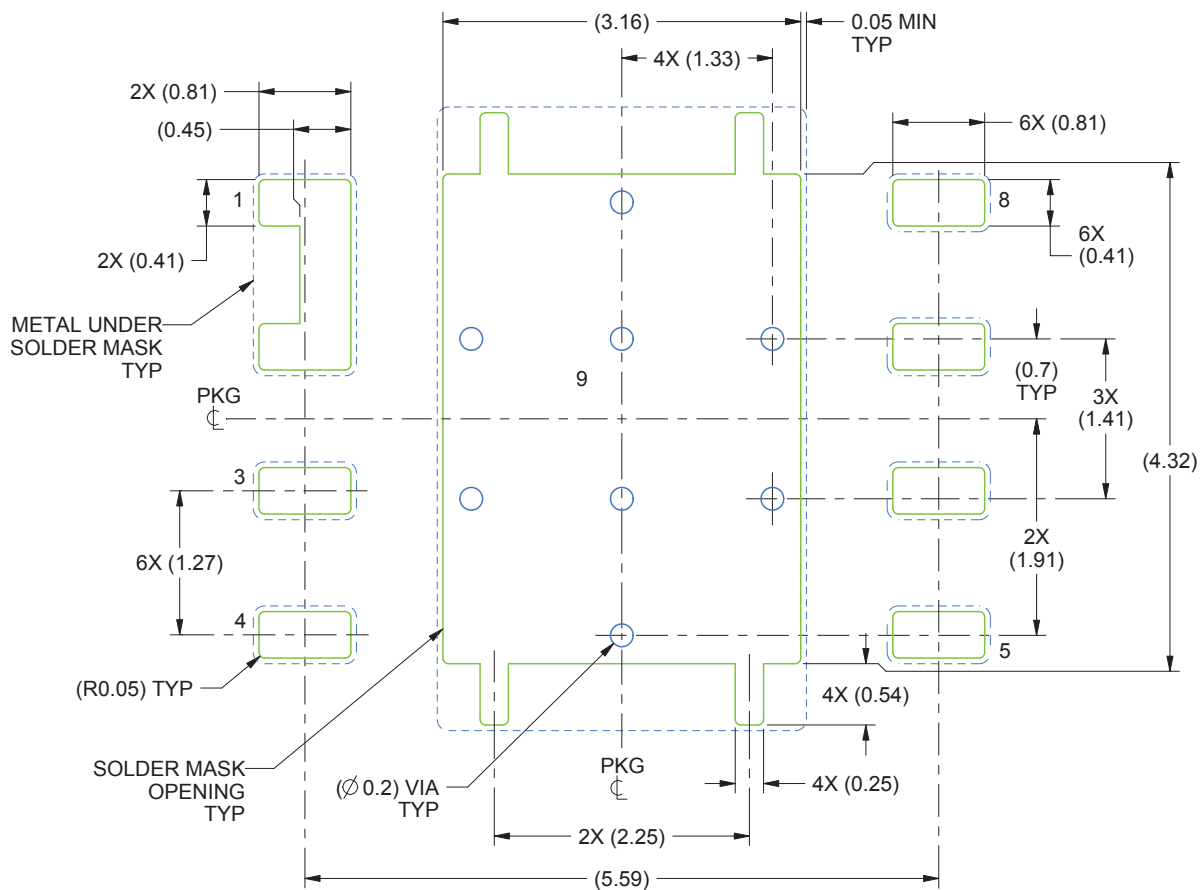

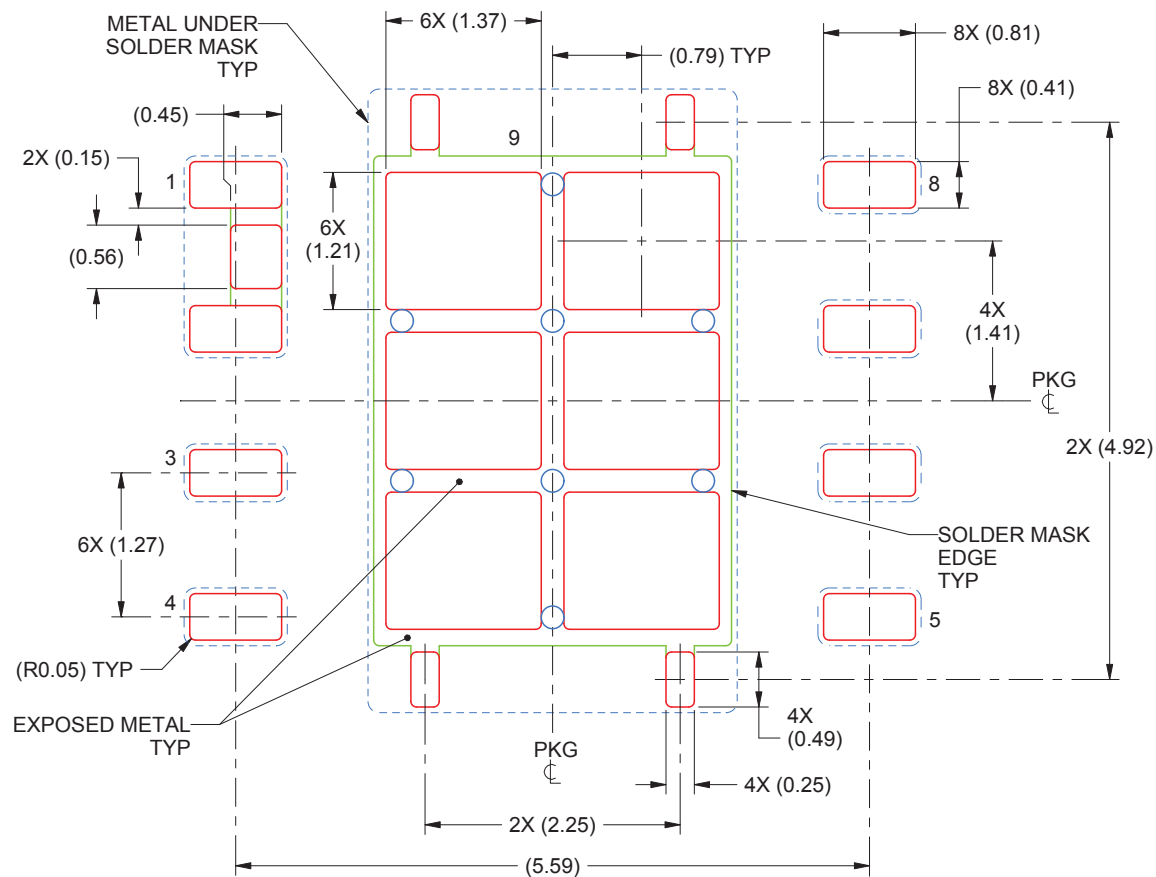

1. 所有线性尺寸的单位均为毫米。括号中的任何尺寸仅供参考。尺寸和公差值符合 ASME Y14.5M 标准。
2. 此封装设计用于焊接到电路板的散热焊盘上。有关更多信息，请参阅《[QFN/SON PCB 连接](#)》应用报告 (SLUA271)。
3. 根据应用决定是否选用过孔，详情请参见器件数据表。如果实现了部分或全部过孔，则会显示建议的过孔位置。

9.4 模版建议



1. 所有线性尺寸的单位均为毫米。括号中的任何尺寸仅供参考。尺寸和公差值符合 ASME Y14.5M 标准。
2. 具有漏斗形壁和圆角的激光切割孔可提供更佳的锡膏脱离。IPC-7525 可能提供替代设计建议。

PACKAGING INFORMATION

| Orderable Device | Status (1) | Package Type | Package Drawing | Pins | Package Qty | Eco Plan (2) | Lead finish/ Ball material (6) | MSL Peak Temp (3) | Op Temp (°C) | Device Marking (4/5) | Samples |
|------------------|---------------|--------------|-----------------|------|-------------|---------------------|--------------------------------------|----------------------|--------------|-------------------------|---|
| CSD86356Q5D | ACTIVE | VSON-CLIP | DMV | 8 | 2500 | RoHS-Exempt & Green | SN | Level-1-260C-UNLIM | -55 to 150 | 86356D |  |
| CSD86356Q5DT | ACTIVE | VSON-CLIP | DMV | 8 | 250 | RoHS-Exempt & Green | SN | Level-1-260C-UNLIM | -55 to 150 | 86356D |  |

(1) The marketing status values are defined as follows:

ACTIVE: Product device recommended for new designs.

LIFEBUY: TI has announced that the device will be discontinued, and a lifetime-buy period is in effect.

NRND: Not recommended for new designs. Device is in production to support existing customers, but TI does not recommend using this part in a new design.

PREVIEW: Device has been announced but is not in production. Samples may or may not be available.

OBSOLETE: TI has discontinued the production of the device.

(2) **RoHS:** TI defines "RoHS" to mean semiconductor products that are compliant with the current EU RoHS requirements for all 10 RoHS substances, including the requirement that RoHS substance do not exceed 0.1% by weight in homogeneous materials. Where designed to be soldered at high temperatures, "RoHS" products are suitable for use in specified lead-free processes. TI may reference these types of products as "Pb-Free".

RoHS Exempt: TI defines "RoHS Exempt" to mean products that contain lead but are compliant with EU RoHS pursuant to a specific EU RoHS exemption.

Green: TI defines "Green" to mean the content of Chlorine (Cl) and Bromine (Br) based flame retardants meet JS709B low halogen requirements of <=1000ppm threshold. Antimony trioxide based flame retardants must also meet the <=1000ppm threshold requirement.

(3) MSL, Peak Temp. - The Moisture Sensitivity Level rating according to the JEDEC industry standard classifications, and peak solder temperature.

(4) There may be additional marking, which relates to the logo, the lot trace code information, or the environmental category on the device.

(5) Multiple Device Markings will be inside parentheses. Only one Device Marking contained in parentheses and separated by a "~" will appear on a device. If a line is indented then it is a continuation of the previous line and the two combined represent the entire Device Marking for that device.

(6) Lead finish/Ball material - Orderable Devices may have multiple material finish options. Finish options are separated by a vertical ruled line. Lead finish/Ball material values may wrap to two lines if the finish value exceeds the maximum column width.

Important Information and Disclaimer: The information provided on this page represents TI's knowledge and belief as of the date that it is provided. TI bases its knowledge and belief on information provided by third parties, and makes no representation or warranty as to the accuracy of such information. Efforts are underway to better integrate information from third parties. TI has taken and continues to take reasonable steps to provide representative and accurate information but may not have conducted destructive testing or chemical analysis on incoming materials and chemicals. TI and TI suppliers consider certain information to be proprietary, and thus CAS numbers and other limited information may not be available for release.

In no event shall TI's liability arising out of such information exceed the total purchase price of the TI part(s) at issue in this document sold by TI to Customer on an annual basis.

TAPE AND REEL INFORMATION

QUADRANT ASSIGNMENTS FOR PIN 1 ORIENTATION IN TAPE

*All dimensions are nominal

| Device | Package Type | Package Drawing | Pins | SPQ | Reel Diameter (mm) | Reel Width W1 (mm) | A0 (mm) | B0 (mm) | K0 (mm) | P1 (mm) | W (mm) | Pin1 Quadrant |
|--------------|--------------|-----------------|------|-----|--------------------|--------------------|---------|---------|---------|---------|--------|---------------|
| CSD86356Q5DT | VSON-CLIP | DMV | 8 | 250 | 330.0 | 12.4 | 5.3 | 6.3 | 1.2 | 8.0 | 12.0 | Q2 |

TAPE AND REEL BOX DIMENSIONS

*All dimensions are nominal

| Device | Package Type | Package Drawing | Pins | SPQ | Length (mm) | Width (mm) | Height (mm) |
|--------------|--------------|-----------------|------|-----|-------------|------------|-------------|
| CSD86356Q5DT | VSON-CLIP | DMV | 8 | 250 | 336.6 | 336.6 | 41.3 |

重要声明和免责声明

TI“按原样”提供技术和可靠性数据（包括数据表）、设计资源（包括参考设计）、应用或其他设计建议、网络工具、安全信息和其他资源，不保证没有瑕疵且不做任何明示或暗示的担保，包括但不限于对适销性、某特定用途方面的适用性或不侵犯任何第三方知识产权的暗示担保。

这些资源可供使用 TI 产品进行设计的熟练开发人员使用。您将自行承担以下全部责任：(1) 针对您的应用选择合适的 TI 产品，(2) 设计、验证并测试您的应用，(3) 确保您的应用满足相应标准以及任何其他功能安全、信息安全、监管或其他要求。

这些资源如有变更，恕不另行通知。TI 授权您仅可将这些资源用于研发本资源所述的 TI 产品的应用。严禁对这些资源进行其他复制或展示。您无权使用任何其他 TI 知识产权或任何第三方知识产权。您应全额赔偿因在这些资源的使用中对 TI 及其代表造成的任何索赔、损害、成本、损失和债务，TI 对此概不负责。

TI 提供的产品受 [TI 的销售条款](#) 或 [ti.com](#) 上其他适用条款/TI 产品随附的其他适用条款的约束。TI 提供这些资源并不会扩展或以其他方式更改 TI 针对 TI 产品发布的适用的担保或担保免责声明。

TI 反对并拒绝您可能提出的任何其他或不同的条款。

邮寄地址：Texas Instruments, Post Office Box 655303, Dallas, Texas 75265

Copyright © 2022，德州仪器 (TI) 公司