

TPS2662x 具有集成输入和输出反极性保护功能的 60V 800mA 工业电子保险丝

1 特性

- 工作电压为 4.5V 至 60V，绝对最大值为 62V
- 集成反向输入极性保护，低至 -60V
- 集成反向输出极性保护，低至 $-(60 - V_{IN})$ (仅限 TPS26624 和 TPS26625)
- 总 RON 为 478mΩ 的集成背对背 MOSFET
- 25mA 至 880mA 可调节电流限制 (880mA 时精度为 ±5%)
- 使用最少的外部组件在浪涌期间提供负载保护 (IEC 61000-4-5)
- 符合 IEC 61000-4-4 标准的电气快速瞬变抗扰度
- 快速反向电流阻断响应 (0.3μs)
- 可调节 UVLO、OVP 切断、输出压摆率控制，用于浪涌电流限制
- 38V 固定过压钳位 (仅限 TPS26622 和 TPS26623)
- 低静态电流 (工作时为 340μA，关断时为 12μA)
- 小尺寸 - 10L (3mm × 3mm) VSON
- 通过 UL 2367 认证
 - 文件编号 169910
 - $R_{ILIM} \geq 7.5k\Omega$ (最大电流为 0.91A)
- 通过 IEC 62368-1 认证

2 应用

- PLC I/O 模块
- 交流和伺服驱动器
- 传感器和控制
- 恒温器
- PoE 高侧保护

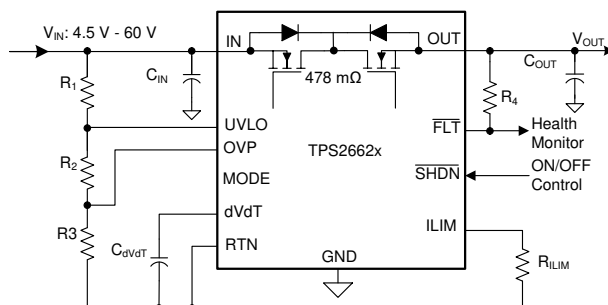

简化版原理图

3 说明

TPS2662x 系列高电压电子保险丝设计紧凑，功能丰富，且具有一整套保护功能。4.5V 至 60V 的宽电源输入范围可实现对众多常用直流总线电压的控制。该器件可以承受并保护由高达 ±60V 的正负电源供电的负载。TPS26624 和 TPS26625 器件支持输入和输出反极性保护功能。集成的背对背 FET 可提供反向电流阻断功能，因此该器件适用于在电源故障和欠压条件下要求保持输出电压的系统。负载、电源和器件保护具有许多可调特性，包括过流、输出压摆率和过压、欠压阈值。TPS2662x 系列内部可靠的保护控制模块以及高额定电压有助于简化针对浪涌保护的系统设计。

TPS26620、TPS26622 和 TPS26624 具有闭锁功能，TPS26621、TPS26623 和 TPS26625 具有自动重试功能，用于应对过热和过流故障事件。

这些器件采用 3mm × 3mm 10 引脚 SON 封装，额定工作温度范围为 -40°C 至 +125°C。

器件信息⁽¹⁾

器件型号	封装	封装尺寸 (标称值)
TPS26620	SON (10)	3.00mm × 3.00mm
TPS26621		
TPS26622		
TPS26623		
TPS26624		
TPS26625		

(1) 如需了解所有可用封装，请参阅数据表末尾的可订购产品附录。

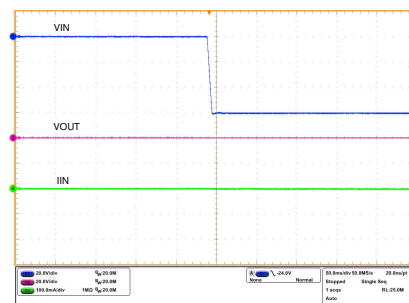

- 60V 电源时的反向输入极性保护



Table of Contents

1 特性	1	10 Application and Implementation	25
2 应用	1	10.1 Application Information.....	25
3 说明	1	10.2 Typical Application.....	25
4 Revision History	2	10.3 System Examples.....	31
5 Device Comparison Table	4	10.4 Do's and Don'ts.....	32
6 Pin Configuration and Functions	4	11 Power Supply Recommendations	33
7 Specifications	5	11.1 Transient Protection.....	33
7.1 Absolute Maximum Ratings.....	5	12 Layout	35
7.2 ESD Ratings.....	5	12.1 Layout Guidelines.....	35
7.3 Recommended Operating Conditions.....	5	12.2 Layout Example.....	36
7.4 Thermal Information.....	6	13 Device and Documentation Support	37
7.5 Electrical Characteristics.....	6	13.1 Documentation Support.....	37
7.6 Timing Requirements.....	8	13.2 接收文档更新通知.....	37
7.7 Typical Characteristics.....	9	13.3 支持资源.....	37
8 Parameter Measurement Information	14	13.4 Trademarks.....	37
9 Detailed Description	15	13.5 Electrostatic Discharge Caution.....	37
9.1 Overview.....	15	13.6 术语表.....	37
9.2 Functional Block Diagram.....	16	14 Mechanical, Packaging, and Orderable Information	37
9.3 Feature Description.....	16		
9.4 Device Functional Modes.....	24		

4 Revision History

注：以前版本的页码可能与当前版本的页码不同

Changes from Revision E (August 2019) to Revision F (December 2021)	Page
• 更新了整个文档中的表格、图和交叉参考的编号格式.....	1
• Moved I _{SHDN} from Source Current to Sink Current row in the Absolute Maximum Ratings table.....	5
• Changed External Capacitance min from 0.1 to 0.01 in Recommended Operating Conditions table.....	5
• Deleted OVP _{MAX} row in Electrical Characteristics table.....	6
• Changed I _(FLT) test condition in Electrical Characteristics table.....	6
• Deleted UVLO_t _{REC} row in Timing Requirements table.....	8
• Updated the Parameter Measurement Information section.....	14
• Added t _{CL_Dly} description to Overvoltage Protection (OVP) section.....	17
• Changed device mention to TPS2662x to include all variants in Input Side Reverse Polarity Protection section.....	19
• Added UVLO back to the Overload Protection section.....	20
• Added more description and clarification for the t _{CL(dly)} parameter in the Overload Protection section.....	20
• Added minimum voltage to FAULT Response section.....	23

Changes from Revision D (February 2019) to Revision E (August 2019)	Page
• 将特性部分中的“UL 2367 认证正在处理中”更改为“通过 UL 2367 认证”和“通过 IEC 62368-1 认证”	1
• Replaced TPS26623 with TPS26624 for Pin No. 4 SHDN in the Pin Functions table.....	4
• Added UVLO Recovery Time in the Timing Requirements table in the Specifications section.....	5
• Changed Input voltage range MAX from 60 V to 62 V in the Absolute Maximum Ratings table in the Specifications section.....	5
• Changed Input voltage MAX from 57 V to 60 V in the Recommended Operating Conditions table in the Specifications section.....	5
• Updated the Parameter Measurement Information graph to explain the UVLO_t _{REC}	14
• Updated the Feature Description Undervoltage Lockout (UVLO) section to explain the UVLO_t _{REC} timer.....	16
• Updated the Feature Description Undervoltage Lockout (UVLO) section	16

- Removed UVLO from the [Overload Protection](#) section 20

Changes from Revision C (July 2018) to Revision D (February 2019)	Page
• Changed SHDN pin voltage MAX from 4 V to 6 V in the <i>Recommended Operating Conditions</i> table in the Specifications section	5

Changes from Revision B (April 2018) to Revision C (July 2018)	Page
• 将状态从“预告信息”更改为“量产数据”	1

Changes from Revision A (March 2018) to Revision B (April 2018)	Page
• Changed Repinse to Response in the <i>Device Comparison</i> table header	4

Changes from Revision * (October 2017) to Revision A (March 2018)	Page
• 将一页更改为整个数据表.....	1

5 Device Comparison Table

PART NUMBER	OVERVOLTAGE PROTECTION	OVERLOAD and THERMAL FAULT RESPONSE	REVERSE POLARITY PROTECTION
TPS26620	Overvoltage cut-off, adjustable	Latch Off	Input side
TPS26621	Overvoltage cut-off, adjustable	Auto-Retry	Input side
TPS26622	Overvoltage clamp, fixed (38 V)	Latch Off	Input side
TPS26623	Overvoltage clamp, fixed (38 V)	Auto-Retry	Input side
TPS26624	Overvoltage cut-off, adjustable	Latch Off	Input and Output side
TPS26625	Overvoltage cut-off, adjustable	Auto-Retry	Input and Output side

6 Pin Configuration and Functions



图 6-1. DRC Package 10-Pin VSON Top View

表 6-1. Pin Functions

PIN		TYPE	DESCRIPTION
NO.	NAME		
1	IN	Power	Input supply voltage
2	UVLO	I	Resistor programmable undervoltage lockout threshold setting input. An undervoltage event opens the internal FET. If the Undervoltage Lock Out function is not needed, the UVLO terminal must be connected to the IN terminal with at least a 1-MΩ resistor. UVLO pin is 5-V rated and this resistor limits the UVLO pin current to < 60 μA.
3	OVP	I	Resistor programmable overvoltage protection threshold. An overvoltage event opens internal FET. In TPS26620, TPS26621, TPS26624, TPS26625 devices, if overvoltage protection feature is not to be used then connect OVP terminal to RTN. For overvoltage clamp response (TPS26622 and TPS26623 only) connect OVP to RTN externally.
4	SHDN	I	Shutdown pin. Pulling the pin low makes the device to enter into low power shutdown mode. Cycling SHDN low and then back high resets the device that has latched off (TPS26620, TPS26622, TPS26624 only) due to a fault condition.
5	RTN	-	Reference ground for all internal voltages
6	GND	-	System ground
7	ILIM	I/O	A resistor from this pin to RTN sets the overload and short-circuit current limit. See the Overload and Short Circuit Protection section.
8	dVdT	I/O	A capacitor from this pin to RTN sets output voltage slew rate. See the Hot Plug-In and In-Rush Current Control section.
9	FLT	O	Fault event indicator. This pin is an open drain output. If unused, leave floating.
10	OUT	Power	Output voltage
-	PowerPAD™	-	Connect PowerPAD to RTN plane for heat sinking. Do not use PowerPAD as the only electrical connection to RTN.

7 Specifications

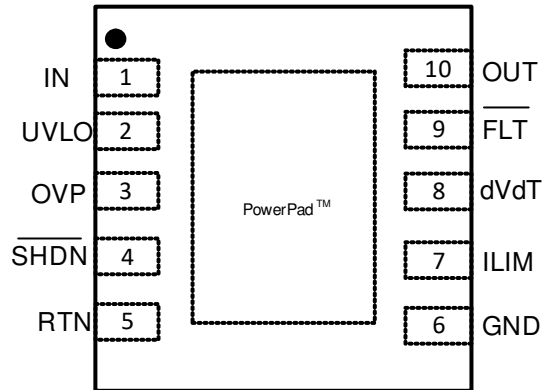
7.1 Absolute Maximum Ratings

over operating free-air temperature range, all voltages referred to GND (unless otherwise noted)⁽¹⁾

		MIN	MAX	UNIT
Input voltage range	IN, IN - OUT	- 60	62	V
	OUT (TPS26624 and TPS26625 Only)	- (60 - V _{IN})	62	
	IN, IN - OUT (10 ms transient), T _A = 25 °C	- 70	70	
	[IN, OUT, FLT, SHDN] to RTN	- 0.3	62	
	[UVLO, OVP, dVdT, ILIM] to RTN	- 0.3	5	
	RTN	- 60	0.3	
Sink current	I _{FLT} , I _{dVdT}		10	mA
Source current	I _{dVdT} , I _{LIM} , I _{SHDN}	Internally limited		
Operating junction temperature	T _J	- 40	150	°C
Transient junction temperature		- 65	T _(TSD)	°C
Storage temperature	T _{stg}	- 65	150	°C

- (1) Stresses beyond those listed under Absolute Maximum Ratings may cause permanent damage to the device. These are stress ratings only, which do not imply functional operation of the device at these or any other conditions beyond those indicated under Recommended Operating Conditions. Exposure to absolute-maximum-rated conditions for extended periods may affect device reliability.

7.2 ESD Ratings

			VALUE	UNIT
V _(ESD)	Electrostatic discharge	Human body model (HBM), per ANSI/ESDA/JEDEC JS-001, all pins ⁽¹⁾	±1500	V
		Charged device model (CDM), per JEDEC specification JESD22-C101, all pins ⁽²⁾	±500	

- (1) JEDEC document JEP155 states that 500-V HBM allows safe manufacturing with a standard ESD control process.
(2) JEDEC document JEP157 states that 250-V CDM allows safe manufacturing with a standard ESD control process.

7.3 Recommended Operating Conditions

over operating free-air temperature range (unless otherwise noted)

		MIN	NOM	MAX	UNIT
IN	Input voltage	4.5		60	V
OUT, FLT	Input voltage	0		60	V
UVLO, OVP, dVdT, ILIM	Input voltage	0		4	V
SHDN	Input voltage	0		6	V
ILIM	Resistance	7.5		267	kΩ
IN, OUT	External capacitance	0.01			μF
dVdT		6.8			nF
T _J	Operating junction temperature	- 40	25	125	°C

7.4 Thermal Information

THERMAL METRIC ⁽¹⁾		TPS2662	UNIT
		DRC (VSON)	
		10 PINS	
R _{θJA}	Junction-to-ambient thermal resistance	44.8	°C/W
R _{θJC(top)}	Junction-to-case (top) thermal resistance	39.5	°C/W
R _{θJB}	Junction-to-board thermal resistance	20.7	°C/W
Ψ _{JT}	Junction-to-top characterization parameter	0.5	°C/W
Ψ _{JB}	Junction-to-board characterization parameter	20.7	°C/W
R _{θJC(bot)}	Junction-to-case (bottom) thermal resistance	3.4	°C/W

(1) For more information about traditional and new thermal metrics, see the [Semiconductor and IC Package Thermal Metrics application](#) report.

7.5 Electrical Characteristics

-40°C ≤ T_A = T_J ≤ +125°C, V_(IN) = 24 V, V_(SHDN) = 2 V, R_(ILIM) = 267 kΩ, $\overline{\text{FLT}}$ = OPEN, C_(OUT) = 1 μF, C_(dVdT) = OPEN. (All voltages referenced to GND, (unless otherwise noted))

PARAMETER		TEST CONDITIONS	MIN	TYP	MAX	UNIT
SUPPLY VOLTAGE						
V _(IN)	Operating input voltage		4.5		60	V
V _(PORR)	Internal POR threshold, rising		3.54	3.73	4.2	V
V _(PORHys)	Internal POR hysteresis			110		mV
I _{Q(ON)}	Supply current	Enabled: V _(SHDN) = 2 V		343	482	μA
I _{Q(OFF)}		V _(SHDN) = 0 V		11.5	25	μA
I _(VINR)	Reverse Input supply current	V _(IN) = -24 V, V _(OUT) = 0 V		50	130	μA
V _(OVC)	Over voltage clamp	V _(IN) > 40 V, I _{LOAD} = 10 mA, TPS26622, TPS26623 Only	36	37.5	40	V
UNDERVOLTAGE LOCKOUT (UVLO) INPUT						
V _(UVLOR)	UVLO threshold voltage, rising		1.18	1.2	1.23	V
V _(UVLOF)	UVLO threshold, Falling		1.09	1.1	1.135	V
I _(UVLO)	UVLO Input Leakage Current	0 V ≤ V _(UVLO) ≤ 3.5 V	-100	0	100	nA
I _(UVLO)	UVLO Input Leakage Current	V _(UVLO) = 5 V		18.8	38	μA
OVER VOLTAGE PROTECTION (OVP) INPUT						
V _(OVPR)	Overvoltage threshold voltage, rising		1.18	1.2	1.23	V
V _(OVPF)	Overvoltage threshold, falling		1.09	1.12	1.135	V
I _(OVP)	OVP Input Leakage Current	0 V ≤ V _(OVP) ≤ 5 V	-100	0	100	nA
LOW IQ SHUTDOWN (SHDN) INPUT						
V _(SHDN)	Output voltage	I _(SHDN) = 0.1 μA	2.39	2.781	3.1	V
V _(SHUTF)	SHDN Threshold Voltage for Low IQ Shutdown, Falling		0.9			V
V _(SHUTR)	SHDN Threshold, rising				1.8	V
I _(SHDN)	Input current	V _(SHDN) = 0.4 V	-10	-2.4		μA
OUTPUT RAMP CONTROL (dVdT)						
I _(dVdT)	dVdT Charging Current	V _(dVdT) = 0V	1.68	1.98	2.33	μA
R _(dVdT)	dVdT Discharging Resistance	V _(SHDN) = 0 V, with I _(dVdT) = 10mA sinking		13.1	22	Ω
V _(dVdTmax)	dVdT Max Capacitor Voltage		4	4.34	4.75	V
GAIN _(dVdT)	dVdT to OUT Gain	V _(OUT) / V _(dVdT)	23.9	24.6	25.2	V/V

7.5 Electrical Characteristics (continued)

$-40^{\circ}\text{C} \leq T_A = T_J \leq +125^{\circ}\text{C}$, $V_{(IN)} = 24\text{ V}$, $V_{(\overline{\text{SHDN}})} = 2\text{ V}$, $R_{(ILIM)} = 267\text{ k}\Omega$, $\overline{\text{FLT}} = \text{OPEN}$, $C_{(OUT)} = 1\text{ }\mu\text{F}$, $C_{(dVdT)} = \text{OPEN}$. (All voltages referenced to GND, (unless otherwise noted))

PARAMETER	TEST CONDITIONS	MIN	TYP	MAX	UNIT	
CURRENT LIMIT PROGRAMMING (ILIM)						
$V_{(ILIM)}$	ILIM bias voltage		1		V	
$I_{(OL)}$	Overload Current Limit	$R_{(ILIM)} = 267\text{ k}\Omega$, $V_{(IN)} - V_{(OUT)} = 1\text{ V}$	0.02	0.025	0.032	A
		$R_{(ILIM)} = 44.2\text{ k}\Omega$, $V_{(IN)} - V_{(OUT)} = 1\text{ V}$	0.145	0.152	0.159	
		$R_{(ILIM)} = 26.7\text{ k}\Omega$, $V_{(IN)} - V_{(OUT)} = 1\text{ V}$	0.237	0.25	0.257	
		$R_{(ILIM)} = 13.3\text{ k}\Omega$, $V_{(IN)} - V_{(OUT)} = 1\text{ V}$	0.47	0.5	0.52	
		$R_{(ILIM)} = 8.25\text{ k}\Omega$, $V_{(IN)} - V_{(OUT)} = 1\text{ V}$	0.757	0.8	0.827	
		$R_{(ILIM)} = 7.5\text{ k}\Omega$, $V_{(IN)} - V_{(OUT)} = 1\text{ V}$	0.83	0.88	0.91	
$I_{(OL_R-OPEN)}$	$R_{(ILIM)} = \text{OPEN}$, Open Resistor Current Limit (single point failure test: UL60950)	8	15.5	27	mA	
$I_{(OL_R-SHORT)}$	$R_{(ILIM)} = \text{SHORT}$, Shorted Resistor Current Limit (single point failure test: UL60950)	31	39.3	51	mA	
$I_{(SCL)}$	Short-Circuit Current Limit	$R_{(ILIM)} = 7.5\text{ k}\Omega$, $V_{(IN)} - V_{(OUT)} = 24\text{ V}$	0.885		A	
$I_{(FAST-TRIP)}$	Fast-Trip Comparator Threshold		1.6		A	
PASS FET OUTPUT (OUT)						
R_{ON}		$0.025\text{ A} \leq I_{(OUT)} \leq 0.8\text{ A}$, $T_J = 25^{\circ}\text{C}$, $R_{(ILIM)} = 7.5\text{ k}\Omega$	435	478	521	m Ω
		$0.025\text{ A} \leq I_{(OUT)} \leq 0.8\text{ A}$, $T_J = 85^{\circ}\text{C}$, $R_{(ILIM)} = 7.5\text{ k}\Omega$		626	685	
		$0.025\text{ A} \leq I_{(OUT)} \leq 0.8\text{ A}$, $-40^{\circ}\text{C} \leq T_J \leq 125^{\circ}\text{C}$, $R_{(ILIM)} = 7.5\text{ k}\Omega$	250	478	800	
$I_{kg(OUT)}$	OUT Leakage Current in Off State	$V_{(IN)} = 57\text{ V}$, $V_{(\overline{\text{SHDN}})} = 0\text{ V}$, $V_{(OUT)} = 0\text{ V}$, Sourcing	4.38		12	μA
		$V_{(IN)} = 0\text{ V}$, $V_{(\overline{\text{SHDN}})} = 0\text{ V}$, $V_{(OUT)} = 24\text{ V}$, Sinking	7.27		102	
		$V_{(IN)} = -57\text{ V}$, $V_{(\overline{\text{SHDN}})} = 0\text{ V}$, $V_{(OUT)} = 0\text{ V}$, Sinking			168	
	OUT leakage current under output reverse polarity condition	$V_{(IN)} = 24\text{ V}$, $V_{(OUT)} = -24\text{ V}$, $V_{(\overline{\text{SHDN}})} = 2\text{ V}$, TP26624, TPS26625 Only	450			
$V_{(REVTH)}$	$V_{(IN)} - V_{(OUT)}$ threshold for reverse protection comparator, falling		-71	-54	-40	mV
$V_{(FWDTH)}$	$V_{(IN)} - V_{(OUT)}$ threshold for reverse protection comparator, rising		1.4	15	30	mV
FAULT FLAG (FLT): ACTIVE LOW						
$R_{(FLT)}$	$\overline{\text{FLT}}$ Pull-Down Resistance	$V_{(OVP)} = 2\text{ V}$, $I_{(FLT)} = 5\text{ mA}$ sinking	45	82.3	145	Ω
$I_{(FLT)}$	$\overline{\text{FLT}}$ Input Leakage Current	$0\text{ V} \leq V_{(FLT)} \leq 60\text{ V}$	-100	0	100	nA
THERMAL SHUT DOWN (TSD)						
$T_{(TSD)}$	TSD Threshold, rising		155			$^{\circ}\text{C}$
$T_{(TSDhyst)}$	TSD Hysteresis		10			$^{\circ}\text{C}$
	Thermal Fault (Latch or Auto-Retry)	TPS26620, TPS26622, TPS26624		Latch		
		TPS26621, TPS26623, TPS26625		Auto - retry		

7.6 Timing Requirements

-40°C ≤ T_A = T_J ≤ +125°C, V_(IN) = 24 V, V_(SHDN) = 2 V, R_(ILIM) = 267 kΩ, $\overline{\text{FLT}}$ = OPEN, C_(OUT) = 1 μF, C_(dVdT) = OPEN. (All voltages referenced to GND, (unless otherwise noted))

PARAMETER		TEST CONDITIONS	MIN	NOM	MAX	UNIT
IN and UVLO INPUT						
UVLO_t _{ON(dly)}	UVLO Turnon Delay	UVLO ↑ (100 mV above V _(UVLOR)) to V _(OUT) = 100 mV, C _(dVdT) = Open		51		μs
		UVLO ↑ (100 mV above V _(UVLOR)) to V _(OUT) = 100 mV, C _(dVdT) > 4.7 nF, [C _(dVdT) in nF]		51 + 27.4 x C _(dVdT)		μs
UVLO_t _{off(dly)}	UVLO Turnoff delay	UVLO ↓ (100 mV below V _(UVLOF)) to $\overline{\text{FLT}}$ ↓		6.14		μs
SHUTDOWN CONTROL INPUT (SHDN)						
t _{SD(dly)}	SHUTDOWN exit delay	SHDN ↑ to V _(OUT) = 100 mV, C _(dVdT) = Open		156		μs
		SHDN ↑ to V _(OUT) = 100 mV, C _(dVdT) > 4.7 nF, [C _(dVdT) in nF]		156 + 27.4 x C _(dVdT)		μs
	SHUTDOWN entry delay	SHDN ↓ (below SHUTF) to $\overline{\text{FLT}}$ ↓		6.83		μs
OVER VOLTAGE PROTECTION INPUT (OVP)						
t _{OVP(dly)}	OVP Exit delay	OVP ↓ (20 mV below V _(OVPF)) to V _(OUT) = 100 mV, TPS26620/21/24/25 Only		77		μs
	OVP Disable delay	OVP ↑ (20mV above V _(OVPR)) to $\overline{\text{FLT}}$ ↓ , TPS26620/21/24/25 Only		4.84		μs
CURRENT LIMIT						
t _{CL(dly)}	Maximum duration in current limit	I _(ILIM) < I _(OUT) < I _(FAST-TRIP) , V _(IN) - V _(OUT) < 2.6 V		512		ms
t _{FAST-TRIP(dly)}	Fast-Trip Comparator Delay	I _(OUT) > I _(FAST-TRIP) , V _(IN) - V _(OUT) = 2 V		1.5		μs
		I _(OUT) > I _(FAST-TRIP) , 4.5 V < V _(IN) ≤ 6 V, V _(IN) - V _(OUT) ≥ 2.6 V		1.4		μs
		I _(OUT) > I _(FAST-TRIP) , 6 V < V _(IN) ≤ 57 V, V _(IN) - V _(OUT) ≥ 2.6 V		220		ns
REVERSE PROTECTION COMPARATOR						
t _{REV(dly)}	Reverse Protection Comparator Delay	(V _(IN) - V _(OUT)) ↓ (10 mV overdrive below V _(REVTH)) to internal FET turn OFF		15		μs
		(V _(IN) - V _(OUT)) ↓ (1 V overdrive below V _(REVTH)) to internal FET turn OFF		3.71		
		(V _(IN) - V _(OUT)) ≤ - 2.6 V to internal FET turn OFF		0.31		
		(V _(IN) - V _(OUT)) ↓ (150 mV overdrive below V _(REVTH)) to $\overline{\text{FLT}}$ ↓		45		
t _{FWD(dly)}		(V _(IN) - V _(OUT)) ↑ (100 mV overdrive above V _(FWDTH)) to $\overline{\text{FLT}}$ ↑		63		
THERMAL SHUTDOWN						
Retry Delay in TSD				512		ms
OUTPUT RAMP CONTROL (dVdT)						
t _{dVdT}	Output Ramp Time	SHDN ↑ to V _(OUT) = 23.9 V, with C _(dVdT) = 22 nF		11		ms
		SHDN ↑ to V _(OUT) = 23.9 V, with C _(dVdT) = open		0.664		
FAULT FLAG (FLT)						

7.6 Timing Requirements (continued)

$-40^{\circ}\text{C} \leq T_A = T_J \leq +125^{\circ}\text{C}$, $V_{(IN)} = 24\text{ V}$, $V_{(\overline{\text{SHDN}})} = 2\text{ V}$, $R_{(\text{ILIM})} = 267\text{ k}\Omega$, $\overline{\text{FLT}} = \text{OPEN}$, $C_{(\text{OUT})} = 1\text{ }\mu\text{F}$, $C_{(\text{dVdT})} = \text{OPEN}$. (All voltages referenced to GND, (unless otherwise noted))

PARAMETER		TEST CONDITIONS	MIN	NOM	MAX	UNIT
t_{PGOODF}	PGOOD Delay	Falling edge		875		μs
t_{PGOODR}		Rising edge, $C_{(\text{dVdT})} = \text{Open}$		1.4		ms
		Rising edge, $C_{(\text{dVdT})} > 4.7\text{ nF}$, [$C_{(\text{dVdT})}$ in nF]			750 + 573 x $C_{(\text{dVdT})}$	

7.7 Typical Characteristics



图 7-1. On-Resistance vs Temperature Across Load Current



图 7-2. UVLO Threshold Voltage vs Temperature

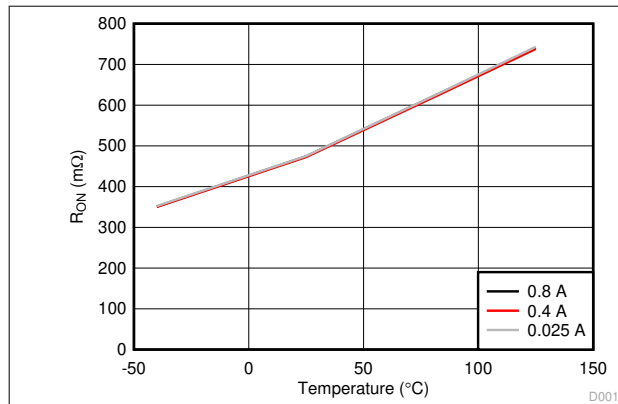

图 7-3. OVP Threshold Voltage vs Temperature

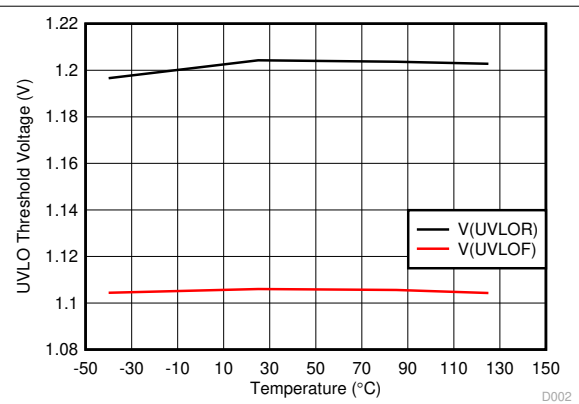

图 7-4. Reverse Voltage Threshold vs Temperature

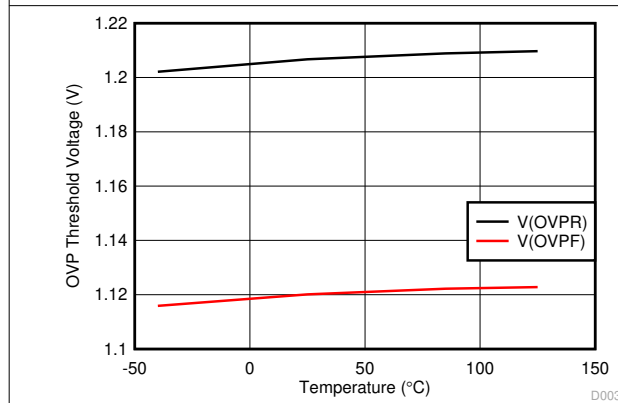

图 7-5. $V_{(\text{FWDTH})}$ vs Temperature

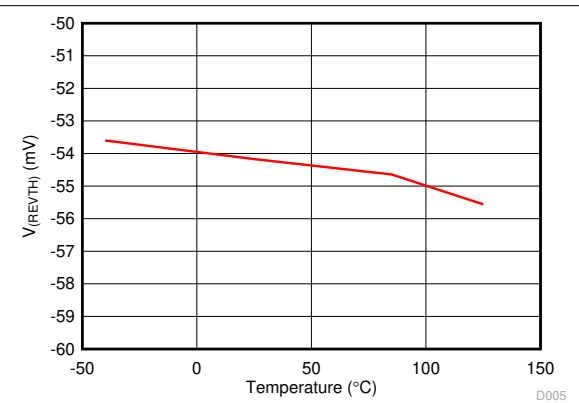

图 7-6. Overvoltage Clamp Threshold vs Temperature

7.7 Typical Characteristics (continued)

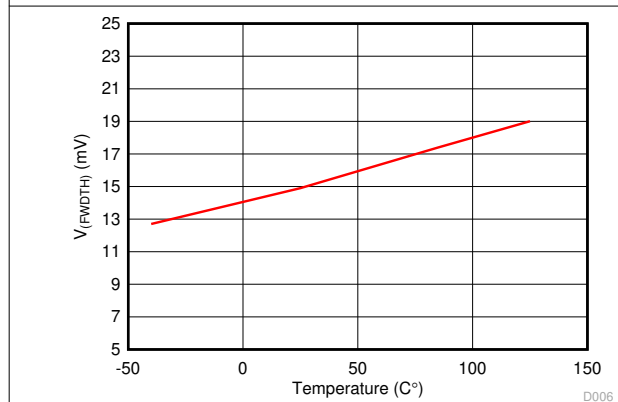

图 7-7. Internal POR Threshold Voltage vs Temperature

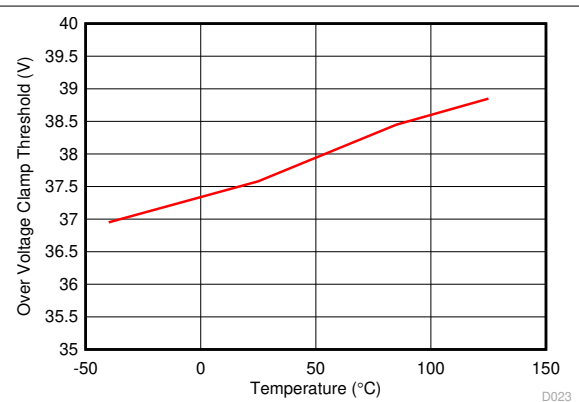

图 7-8. Input Supply Current vs Supply Voltage in Shutdown

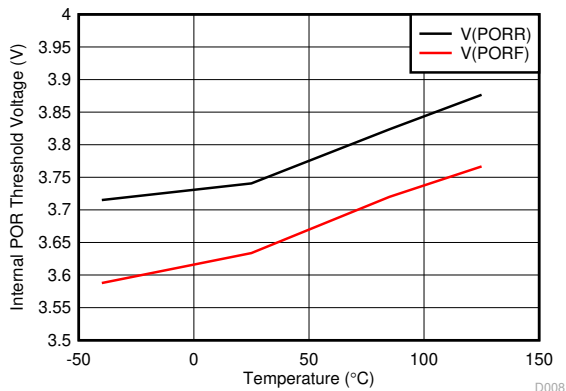

图 7-9. Input Supply Current vs Supply Voltage During Normal Operation

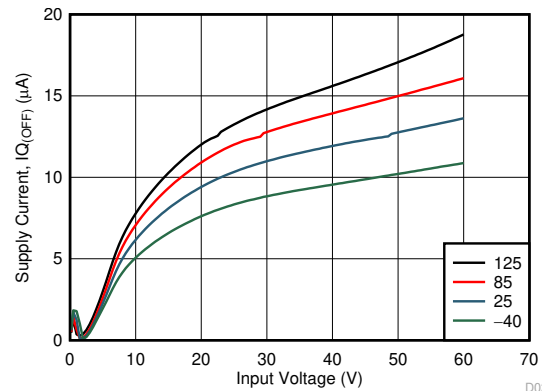

$V_{(OUT)} = 0\text{ V}$

图 7-10. Input Supply Current vs Reverse Supply Voltage, $-V_{(IN)}$

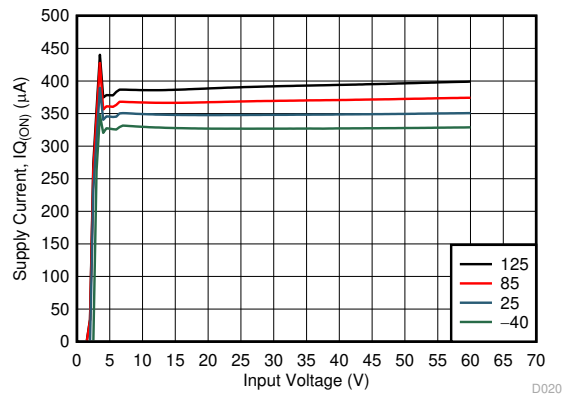
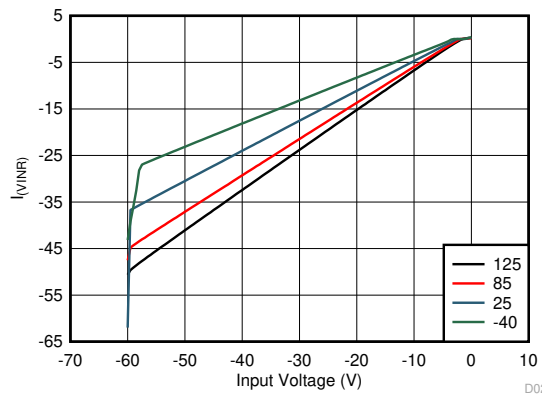

图 7-11. OVP Disable Delay vs Temperature



图 7-12. Shutdown Entry Delay vs Temperature

7.7 Typical Characteristics (continued)

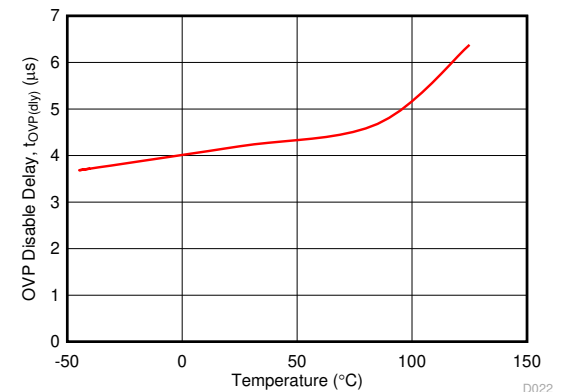

图 7-13. Shutdown Threshold Voltage Shutdown vs Temperature

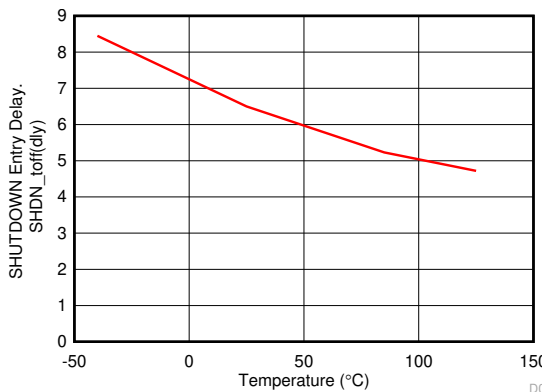

图 7-14. Max Duration in Current Limiting $t_{(CL)}$ vs Temperature

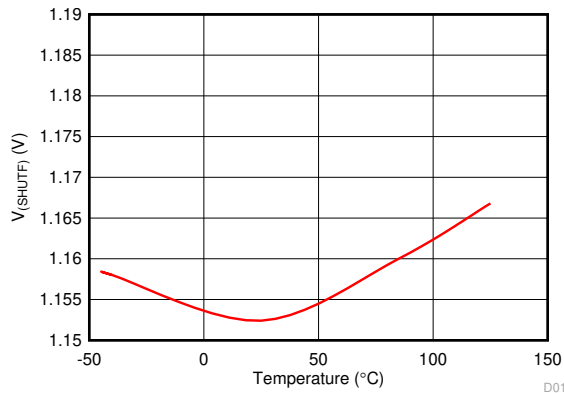

图 7-15. Current Limit (% Normalized) vs Temperature

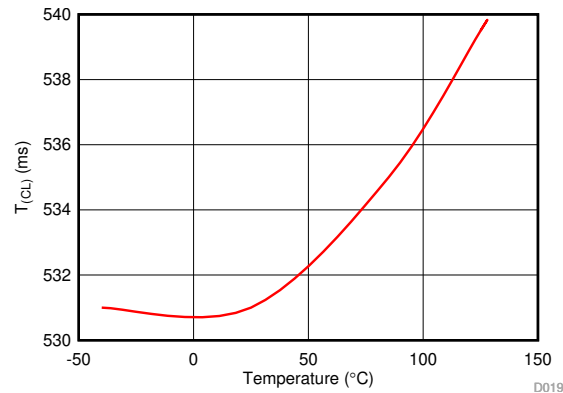

图 7-16. Current Limit (% Normalized) vs Temperature

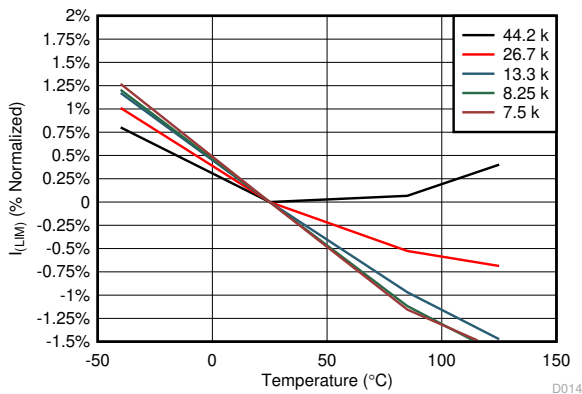

图 7-17. Over Load Current Limit vs Temperature

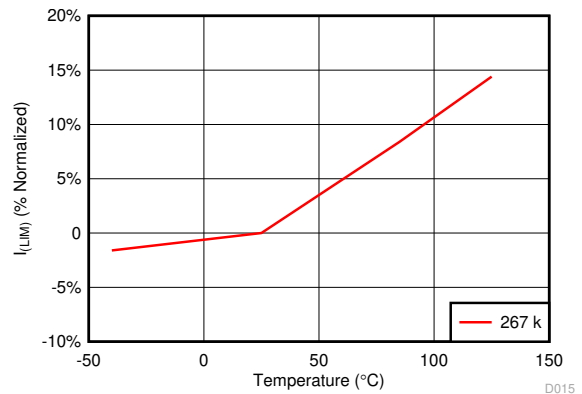

图 7-18. Current Limit for $R_{(ILIM)}$ = Open and Short vs Temperature

7.7 Typical Characteristics (continued)

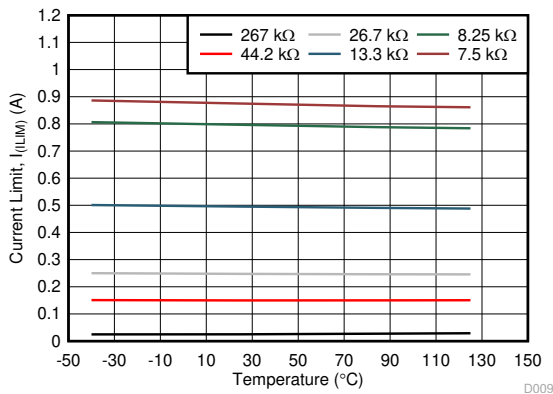

图 7-19. Fast-Trip Comparator Threshold $I_{(FAST-TRIP)}$ vs Temperature Threshold

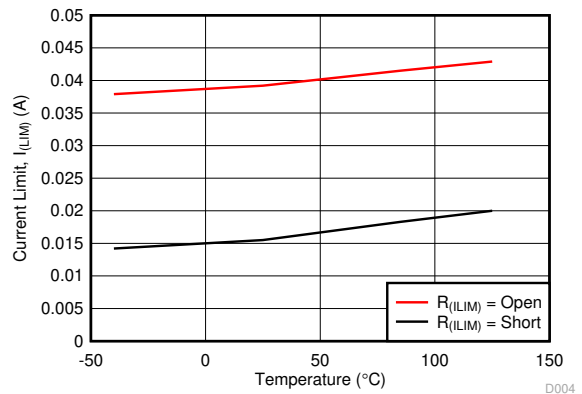

图 7-20. Current Limit Accuracy vs Current Limit, $I_{(OL)}$

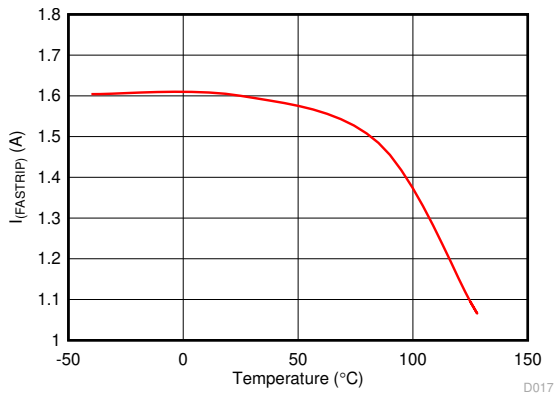

图 7-21. UVLO Turnoff Delay vs Temperature

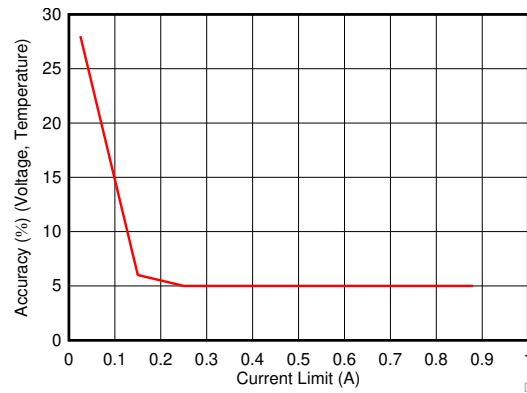

图 7-22. Reverse Current Blocking Response Time vs Reverse Comparator Overdrive Voltage

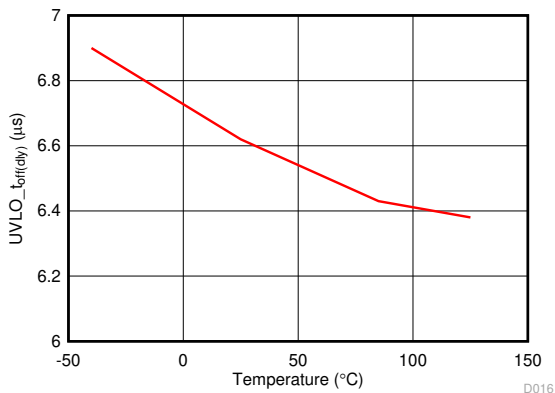

Taken on 2-Layer board, 2 oz.(0.08-mm thick) with RTN plane area: 0.8 cm² (Top) and 4.5 cm² (Bottom)

图 7-23. Thermal Shutdown Time vs Power Dissipation

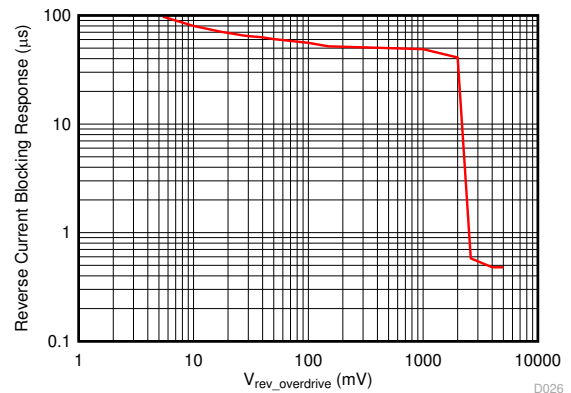
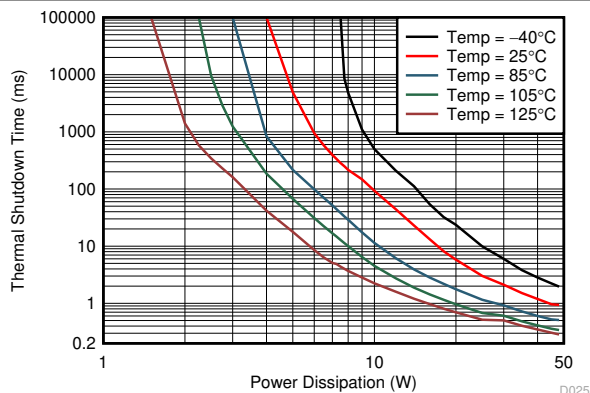
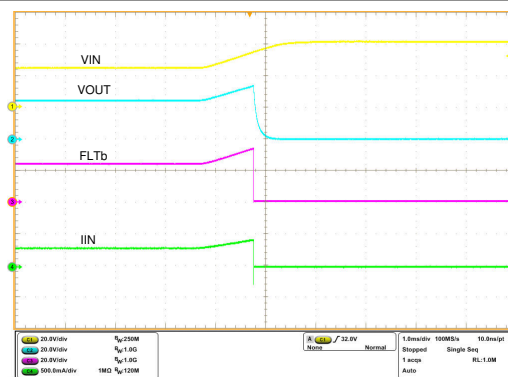

$R_{LIM} = 7.5 \text{ k}\Omega$ $R_{FLTb} = 100 \text{ k}\Omega$ $R_{LOAD} = 80 \Omega$
OVP setting at 33 V

图 7-24. OVP Overvoltage Cut-Off Response

7.7 Typical Characteristics (continued)

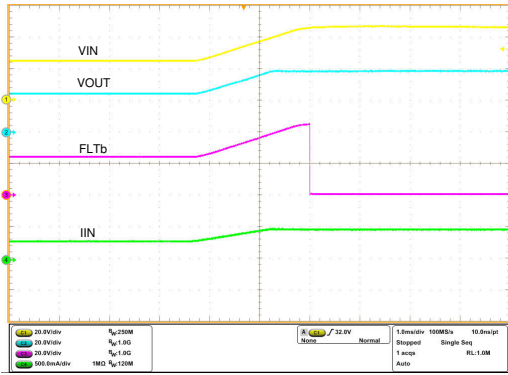

$R_{ILIM} = 7.5\text{ k}\Omega$ $R_{FLTb} = 100\text{ k}\Omega$ $R_{LOAD} = 80\ \Omega$

图 7-25. OV Clamp Response (TPS26602 Only)

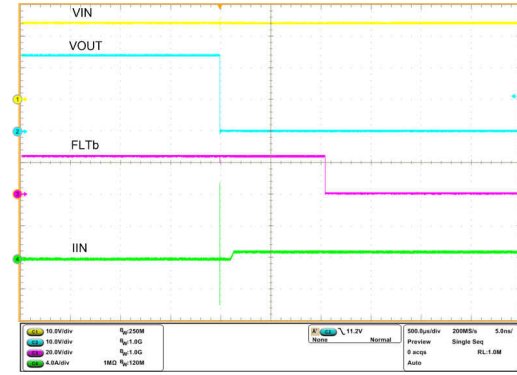

$R_{ILIM} = 7.5\text{ k}\Omega$ $R_{FLTb} = 100\text{ k}\Omega$

图 7-26. Hot-Short: Fast-Trip Response and Current Regulation

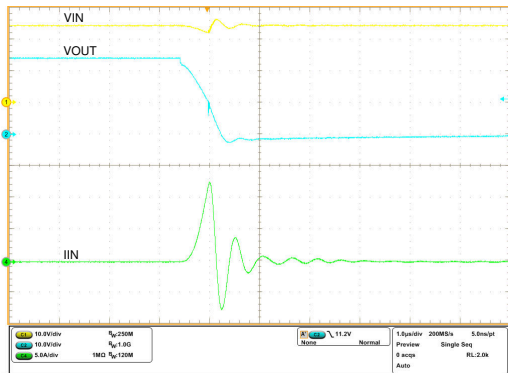

$R_{ILIM} = 7.5\text{ k}\Omega$

图 7-27. Hot-Short: Fast-Trip Response (Zoomed)

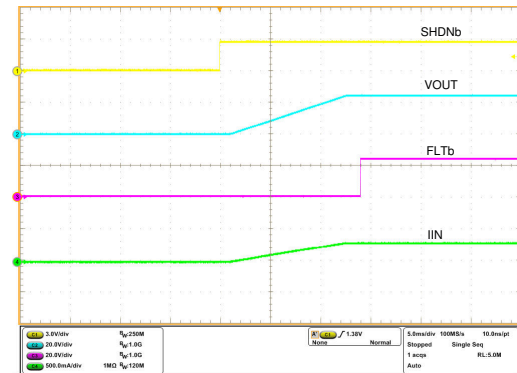

$R_{ILIM} = 7.5\text{ k}\Omega$ $R_{FLTb} = 100\text{ k}\Omega$ $R_{LOAD} = 80\ \Omega$

图 7-28. Turnon Control With SHDN

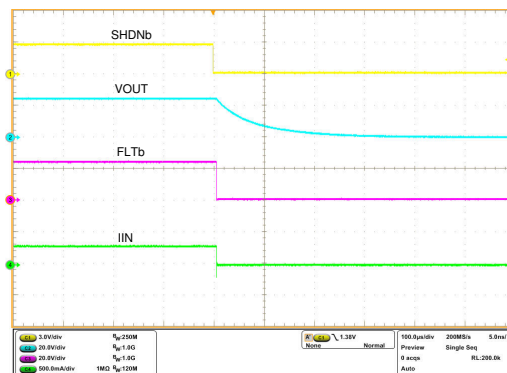

$R_{ILIM} = 7.5\text{ k}\Omega$

$R_{FLTb} = 100\text{ k}\Omega$

$R_{LOAD} = 80\ \Omega$

图 7-29. Turnoff Control With SHDN

8 Parameter Measurement Information



图 8-1. Timing Waveforms

9 Detailed Description

9.1 Overview

The TPS2662x is a family of high voltage industrial eFuses with integrated back-to-back MOSFETs and enhanced built-in protection circuitry. The device provides robust protection for all systems and applications powered from 4.5 V to 60 V. The device can withstand ± 60 -V positive and negative supply voltages without damage. The device features fully integrated reverse polarity protection and require zero additional power components. For hot-pluggable boards, the device provides hot-swap power management with in-rush current control. Load, source, and device protections are provided with many programmable features including overcurrent, overvoltage, undervoltage. The precision overcurrent limit ($\pm 5\%$ at 880 mA) helps to minimize over design of the input power supply, while the fast response short-circuit protection 220 ns (typical) immediately isolates the faulty load from the input supply when a short circuit is detected.

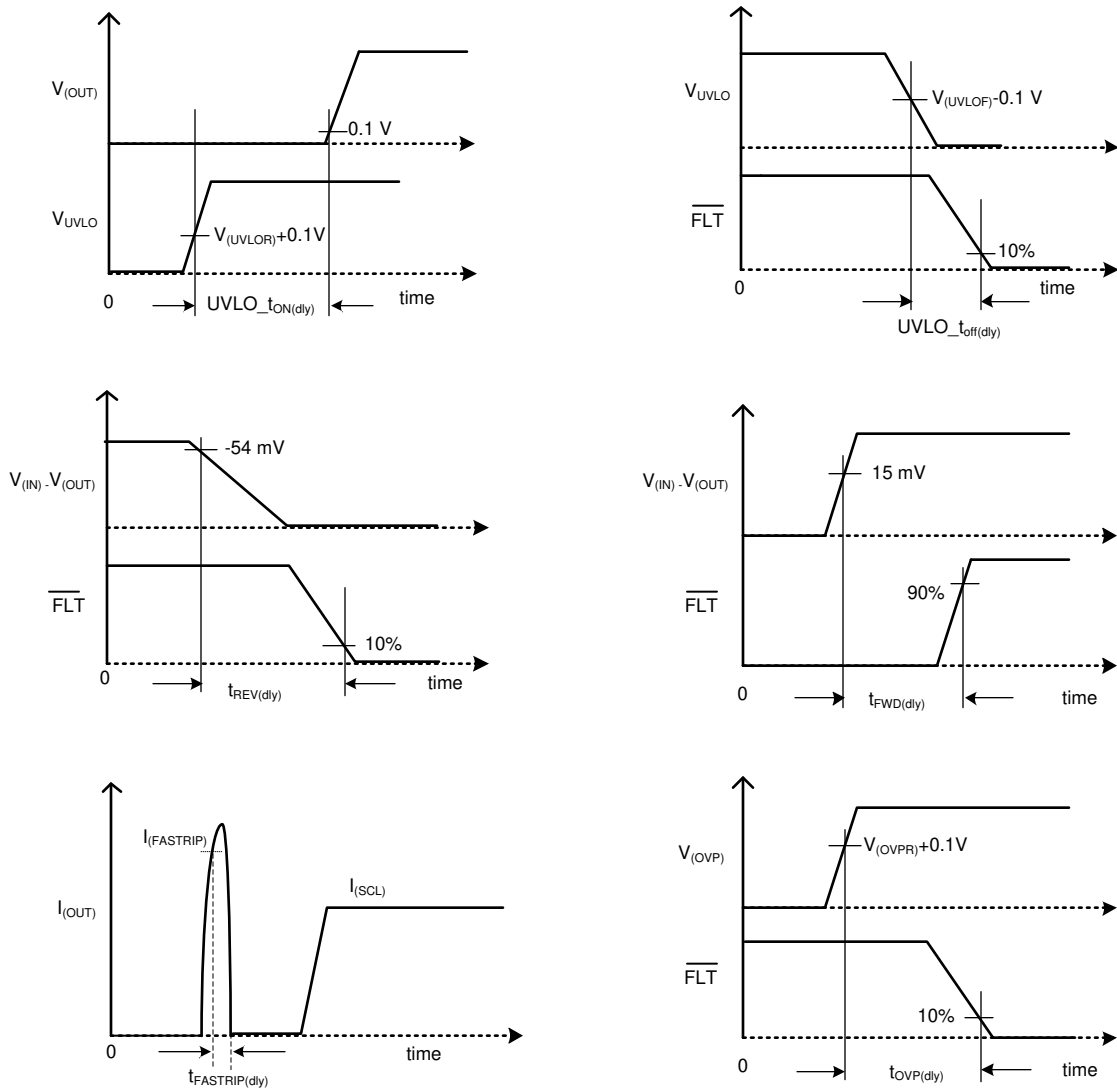
The internal robust protection control blocks of the TPS2662x along with its ± 60 -V rating helps to simplify the system designs for the surge compliance ensuring complete protection of the load and the device. TPS2662x devices are immune to noise tests like Electrical Fast Transients that are common in industrial applications and simplifies the system design that require criterion-A performance during this test.

The device provides precise monitoring of voltage bus for brown-out and overvoltage conditions and asserts fault signal for the downstream system. The TPS2662x monitor functions threshold accuracy of $\pm 3\%$ ensures tight supervision of the supply bus, eliminating the need for a separate supply voltage supervisor chip.

The device monitors $V_{(IN)}$ and $V_{(OUT)}$ to provide true reverse current blocking when a reverse condition or input power failure condition is detected.

9.2 Functional Block Diagram

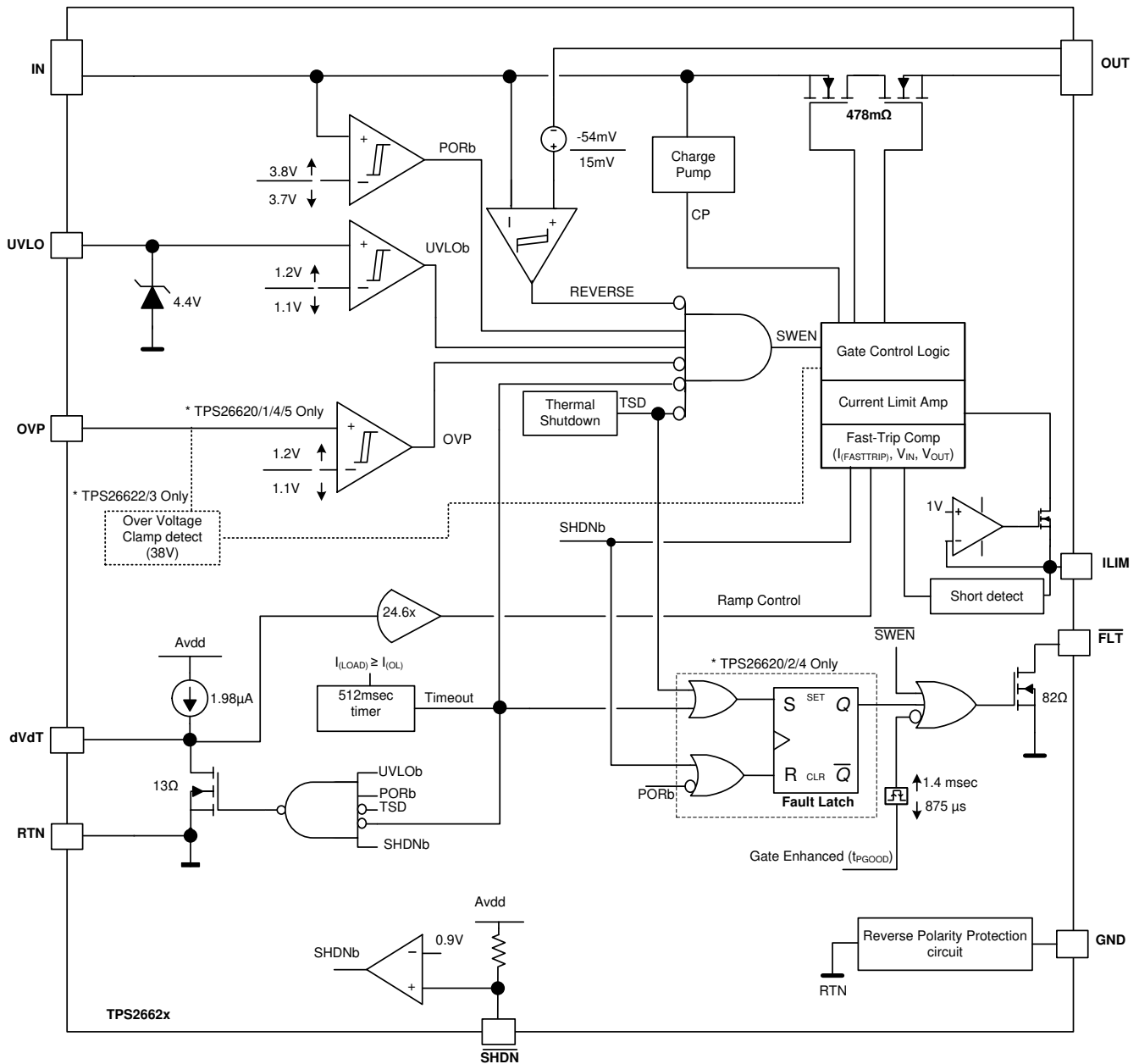

9.3 Feature Description

9.3.1 Undervoltage Lockout (UVLO)

When the voltage at UVLO pin falls below $V_{(UVLOF)}$ during input power fail or input undervoltage fault, the internal FET quickly turns off and FLT is asserted. The UVLO comparator has a hysteresis of 100 mV. To set the input UVLO threshold, connect a resistor divider network from IN supply to UVLO terminal to RTN as shown in [Figure 9-1](#).



图 9-1. UVLO and OVP Thresholds Set by R_1 , R_2 and R_3

If the Undervoltage Lockout function is not needed, the UVLO terminal must be connected to the IN terminal with a 1-M Ω resistor. UVLO pin is 5-V rated and this resistor limits the UVLO pin current to < 60 μ A. The UVLO terminal must not be left floating.

9.3.2 Overvoltage Protection (OVP)

The TPS2662x family incorporate circuitry to protect the system during overvoltage conditions. The TPS26620, TPS26621, TPS26624 and TPS26625 feature overvoltage cut off functionality. A voltage more than $V_{(OVPR)}$ on OVP pin turns off the internal FET and protects the downstream load. To program the OVP threshold externally, connect a resistor divider from IN supply to OVP terminal to RTN as shown in 图 9-1. If the overvoltage feature is not to be used then connect OVP terminal to RTN directly and ensure V_{IN} is not exceeded beyond OVP_{MAX} .

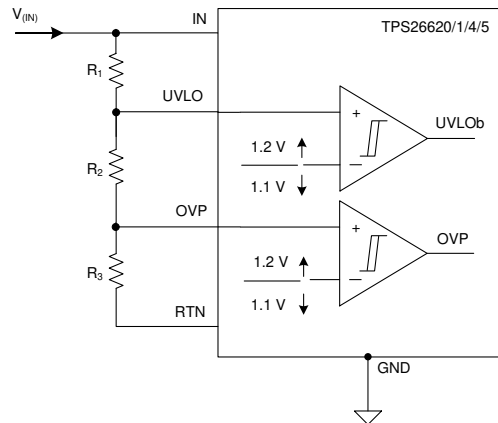
The TPS26622 and TPS26623 feature an internally fixed 38-V overvoltage clamp (V_{OVC}) functionality. The OVP terminal of these devices must be connected to the RTN terminal directly. These devices clamp the output voltage to V_{OVC} , when the input voltage exceeds 38 V. During the output voltage clamp operation, the power dissipation in the internal MOSFET is $P_D = (V_{IN} - V_{OVC}) \times I_{OUT}$. Excess power dissipation for prolonged period can make the device to enter into thermal shutdown. If the device temperature does not reach $T_{(TSD)}$, the device turns off the internal FETs after a delay of t_{CL_Dly} . After the internal FETs are turned off, TPS26622 latches-off and TPS26623 device auto-retries. 图 7-25 illustrates the overvoltage clamp functionality.

9.3.3 Hot Plug-In and Inrush Current Control

The devices are designed to control the inrush current upon insertion of a card into a live backplane or other *hot* power source. This design limits the voltage sag on the backplane's supply voltage and prevents unintended resets of the system power. The controlled start-up also helps to eliminate conductive and radiative interferences. An external capacitor connected from the dVdT pin to RTN defines the slew rate of the output voltage at power-on as shown in 图 9-2 and Figure 9-3.



图 9-2. Output Ramp Up Time t_{dVdT} is Set by $C_{(dVdT)}$

The dVdT pin can be left floating to obtain a predetermined slew rate (t_{dVdT}) on the output. When the terminal is left floating, the devices set an internal output voltage ramp rate of 24 V/660 μ s. A capacitor can be connected from dVdT pin to RTN to program the output voltage slew rate slower than 24 V/660 μ s. Use [方程式 1](#) and [方程式 2](#) to calculate the external $C_{(dVdT)}$ capacitance.

[方程式 1](#) governs slew rate at start-up.

$$I_{(dVdT)} = \left(\frac{C_{(dVdT)}}{\text{Gain}_{(dVdT)}} \right) \times \left(\frac{dV_{(OUT)}}{dt} \right) \quad (1)$$

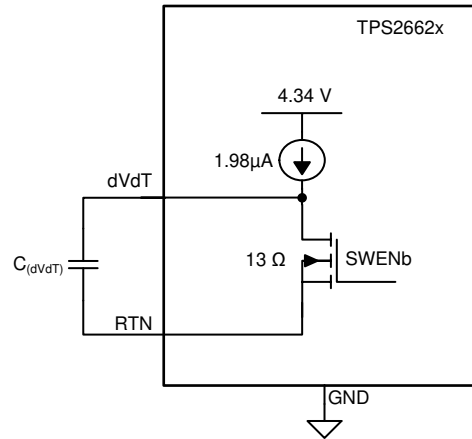
where

- $I_{(dVdT)} = 1.98 \mu\text{A}$ (typical)
- $\frac{dV_{(OUT)}}{dt}$ = Desired output slew rate
- $\text{Gain}_{(dVdT)} = \text{dVdT to } V_{OUT} \text{ gain} = 24.6$

The total ramp time (t_{dVdT}) of $V_{(OUT)}$ for 0 to $V_{(IN)}$ can be calculated using [方程式 2](#).

$$t_{dVdT} = 20.5 \times 10^3 \times V_{(IN)} \times C_{(dVdT)} \quad (2)$$



图 9-3. Hot Plug-In and Inrush Current Control at 24-V Input

9.3.4 Reverse Polarity Protection

9.3.4.1 Input Side Reverse Polarity Protection

TPS2662x eFuses feature fully integrated input side reverse polarity protection. The internal FETs of the eFuse turn OFF during the input reverse polarity event and protect the downstream loads from negative supply voltages that can appear due to field mis-wiring on the input power terminals. Figure 9-4 illustrates the reverse input polarity protection functionality.

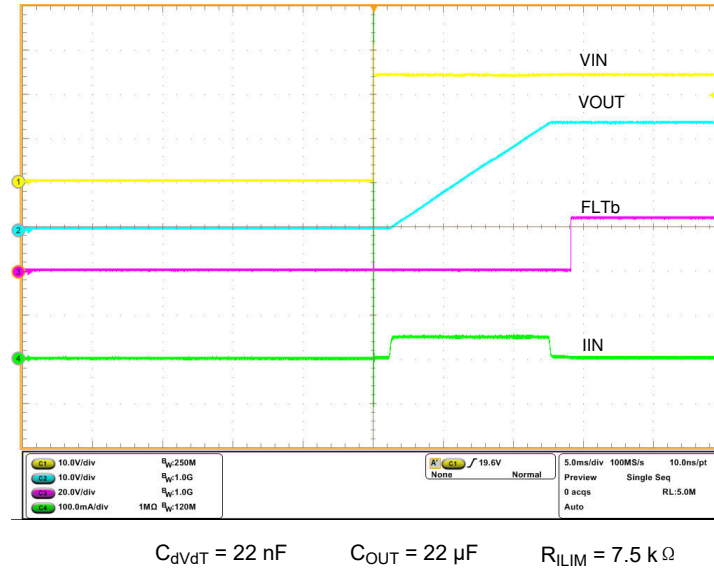

图 9-4. Reverse Input Supply Protection at - 60 V

9.3.4.2 Output Side Reverse Polarity Protection

The TPS26624 and TPS26625 eFuses feature fully integrated input as well as output reverse polarity protection. The internal FETs of the eFuse turn OFF during the output reverse polarity event and protects the upstream circuits from negative voltage that can appear at the output of the eFuse due to field miswiring at the output side with an external isolated power supplies. 图 9-5 illustrates the performance during output side reverse polarity event with $V_{(IN)}$ un-powered and 图 9-6 illustrates the performance with $V_{(IN)}$ powered. 图 9-7 illustrates the output recovery performance after the reverse polarity is removed.

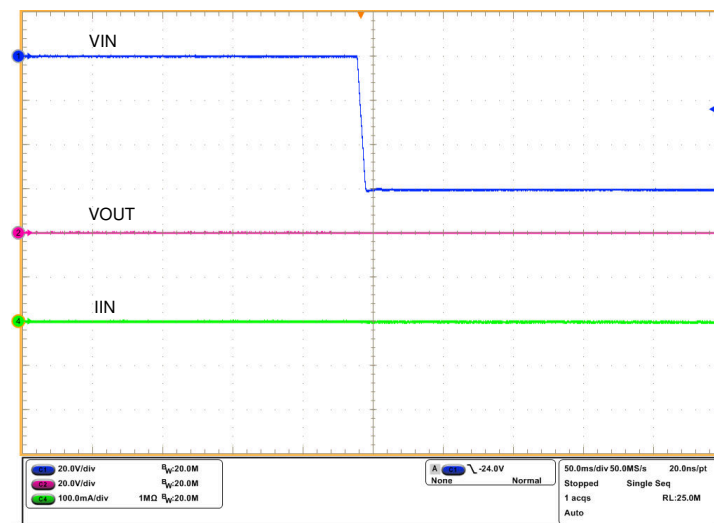

图 9-5. Reverse Output Polarity Protection With - 60 V at OUT and VIN = 0 V



图 9-6. Reverse Output Polarity Protection With - 24 V at OUT and 24 V at IN

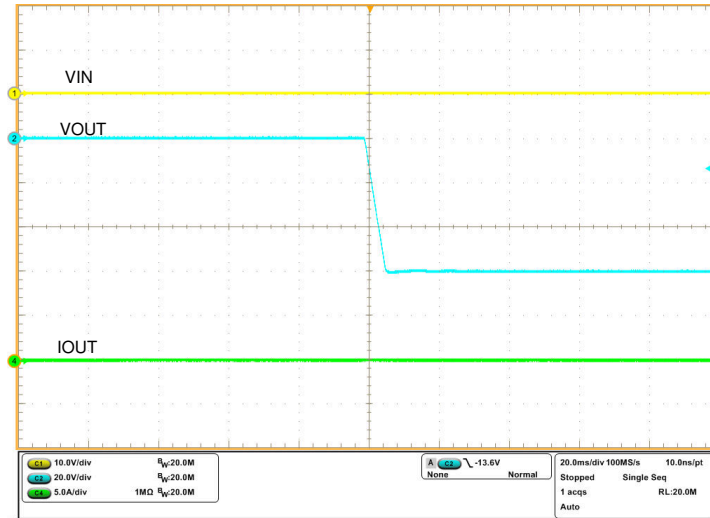

图 9-7. Response During Coming Out of Output Reverse Polarity Fault Condition

9.3.5 Overload and Short-Circuit Protection

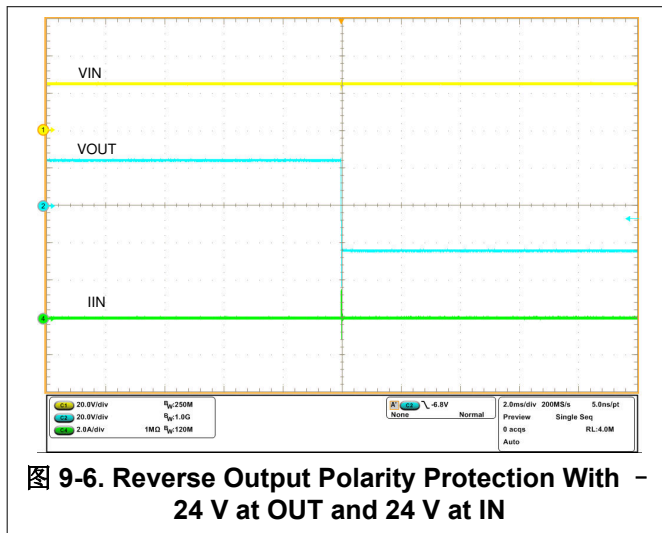
The device monitors the load current by sensing the voltage across the internal sense resistor. The FET current is monitored during start-up and normal operation.

9.3.5.1 Overload Protection

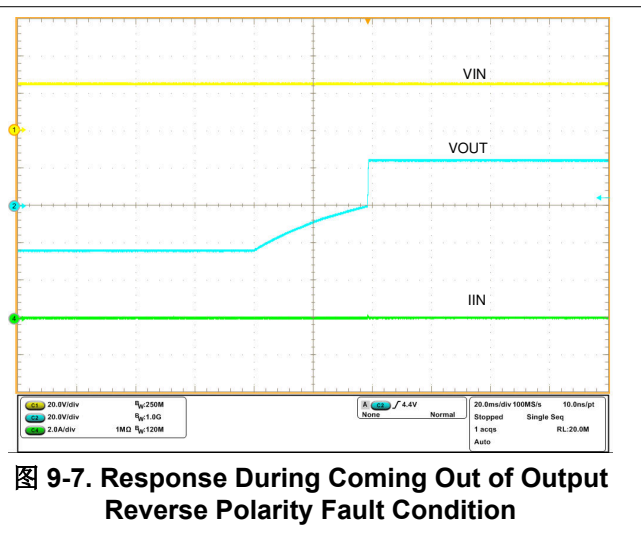
Connect a resistor across ILIM to RTN to program the over load current limit $I_{(OL)}$. During overload conditions, the device regulates the current through it at $I_{(OL)}$ programmed by the $R_{(ILIM)}$ resistor as shown in 方程式 3 for a maximum duration of $t_{CL(dly)}$.

$$I_{OL} = \frac{6.636}{R_{ILIM}} \tag{3}$$

where

- $I_{(OL)}$ is the overload current limit in Ampere
- $R_{(ILIM)}$ is the current limit resistor in k Ω

During the current limit operation the output voltage droops and this can cause the device to hit the thermal shutdown threshold $T_{(TSD)}$ before $t_{CL(dly)}$ time. After the thermal shutdown threshold is hit or $t_{CL(dly)}$ is elapsed,

the internal FETs of TPS2662x turns OFF. FETs in TPS26620, TPS26622 and TPS26624 remain OFF and latched. To reset the latch, cycle the SHDN or UVLO, or recycle the V_{IN}. TPS26621, TPS26623 and TPS26625 commence an auto-retry cycle after a retry time of 512 msec. The internal FETs turn back on in dVdT mode after this retry time. If the overload still exists, then the device regulates the current at programmed current limit, I_(OL). t_{CL(dly)} is the maximum duration for current limiting and estimated as $t_{CL(dly)} = 512 \text{ ms} + [3.3 \times C_{dVdT} / 2 \text{ } \mu\text{A}]$ (C_{dVdT} in nF).

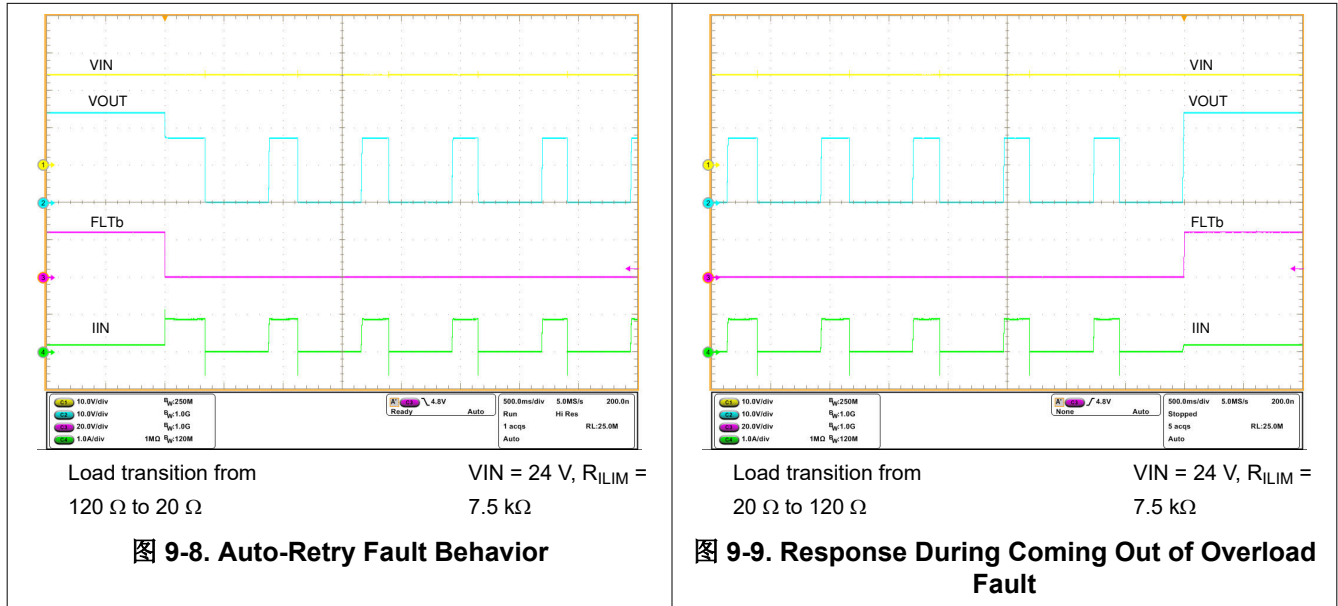

9.3.5.2 Short-Circuit Protection

During a transient output short circuit event, the current through the device increases rapidly. As the current-limit amplifier cannot respond quickly to this event due to its limited bandwidth, the device incorporates a fast-trip comparator. The fast-trip comparator architecture is designed for fast turn OFF ($t_{FAST-TRIP(dly)} = 220 \text{ ns}$ (typical)) of the internal FET during an output short circuit event. The fast-trip threshold is internally set to I_(FAST-TRIP). The fast-trip circuit holds the internal FET off for only a few microseconds, after which the device turns back on slowly, allowing the current-limit loop to regulate the output current to I_(OL). Then the device functions similar to the overload condition. Figure 9-10 and Figure 9-11 illustrate the behavior of the system during output short-circuit condition.

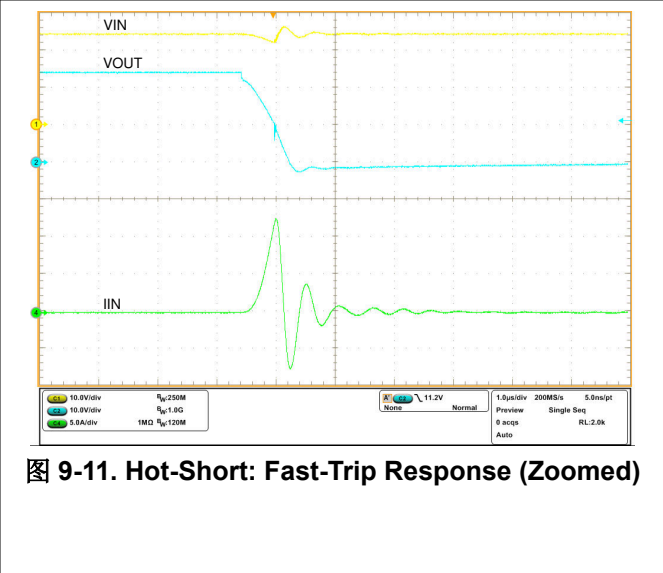
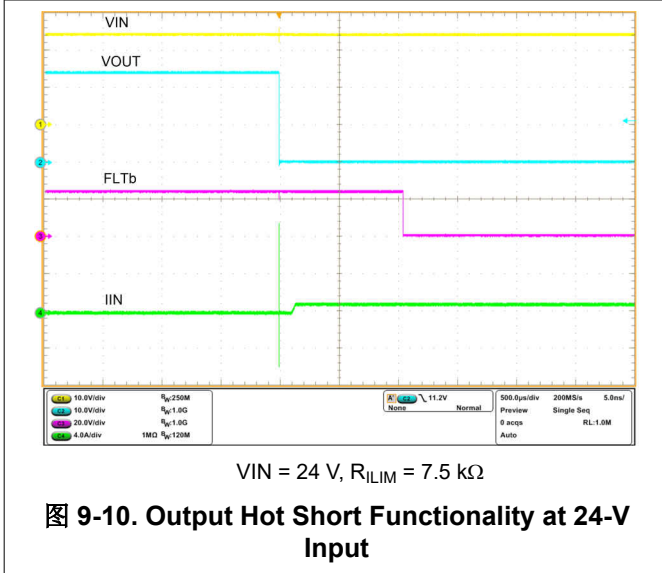

The fast-trip comparator architecture has a supply line noise immunity resulting in a robust performance in noisy environments. This feature is achieved by controlling the turn OFF time of the internal FET based on the differential voltage across $V_{(IN)}$ and $V_{(OUT)}$ after the current through the device exceeds $I_{(FAST-TRIP)}$. Higher the voltage difference $V_{(IN)} - V_{(OUT)}$, faster the turn OFF time, $t_{FAST-TRIP(dly)}$.

9.3.5.2.1 Start-Up With Short-Circuit On Output

When the device is started with short-circuit on the output, it limits the load current to the current limit, $I_{(OL)}$, and functions similar to the overload condition. Figure 9-12 illustrates the function of the device in this condition. This feature helps in quick isolation of the fault and ensures stability of the DC bus.

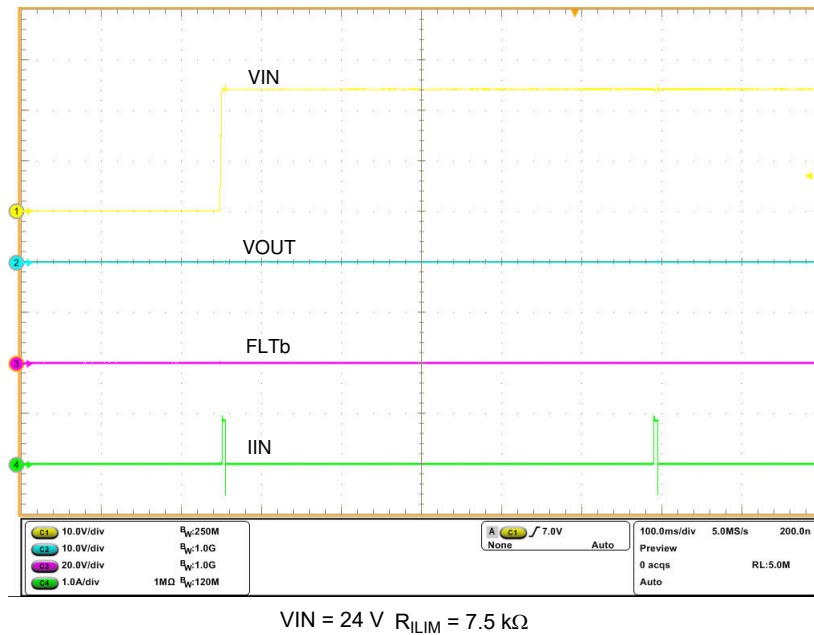

9.3.6 Reverse Current Protection

The device monitors $V_{(IN)}$ and $V_{(OUT)}$ to provide true reverse current blocking when a reverse condition or input power failure condition is detected. The reverse comparator turns OFF the internal FET within 310 ns (typical) as

soon as $V_{(IN)} - V_{(OUT)}$ falls below -2.6 V. The reverse comparator turns on within $63 \mu\text{s}$ (typical) after the differential forward voltage $V_{(IN)} - V_{(OUT)}$ exceeds 115 mV. 图 9-13 and 图 9-14 illustrate the behavior of the system during input hot short circuit condition.



图 9-13. Input Hot Short Functionality at 24-V Supply



图 9-14. Hot-Short: Fast-Trip Response (Zoomed)

The reverse comparator architecture has a supply line noise immunity resulting in a robust performance in noisy environments. This feature is achieved by controlling the turn OFF time of the internal FET based on the over-drive differential voltage $V_{(IN)} - V_{(OUT)}$ over $V_{(REVTH)}$. Higher the over-drive, faster the turn OFF time, $t_{REV(dly)}$. Figure 7-22 shows the reverse current blocking response time versus over-drive voltage.

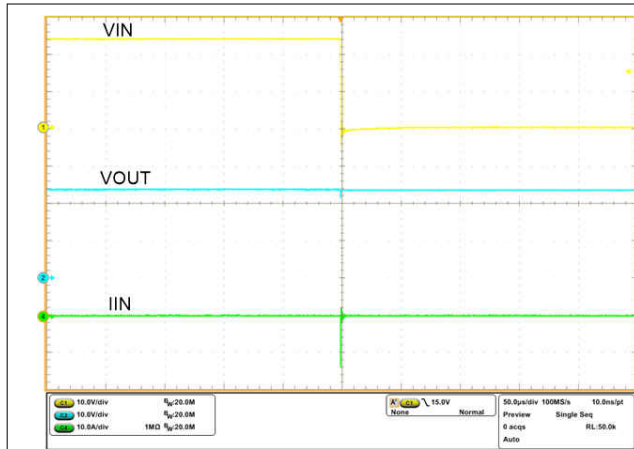
9.3.7 FAULT Response

The FLT open-drain output asserts (active low) under the following conditions:

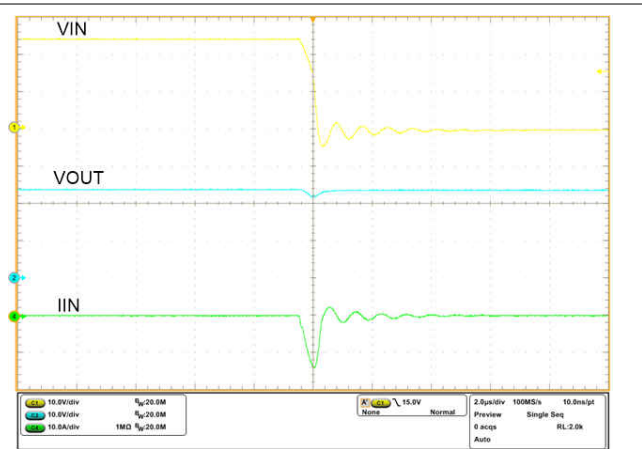
- Fault events such as undervoltage, overvoltage, over load, reverse current and thermal shutdown conditions
- The device enters low current shutdown mode when $\overline{\text{SHDN}}$ is pulled low
- During start-up when the internal FET GATE is not fully enhanced

The device is designed to eliminate false reporting by using an internal *de-glitch* circuit for fault conditions without the need for an external circuitry.

The FLT signal can also be used as a Power Good indicator to the downstream loads like DC/DC converters. An internal Power Good (PGOOD) signal is ORd with the fault logic. During start-up, when the device is operating in dVdT mode, PGOOD and FLT it remains low and is de-asserted after the dVdT mode is completed and the internal FET is fully enhanced. The PGOOD signal has deglitch time incorporated to ensure that internal FET is fully enhanced before heavy load is applied by the downstream converters. Rising deglitch delay is determined by $t_{PGOOD(deg)} = \text{Maximum} \{(750 + 573 \times C_{(dVdT)}), t_{PGOODR}\}$, where $C_{(dVdT)}$ is in nF and $t_{PGOOD(deg)}$ is in μs . FLT can be left open or connected to RTN when not used. $V_{(IN)}$ falling below 3.4 V resets FLT.

9.3.8 IN, OUT, RTN, and GND Pins

TI recommends a ceramic bypass capacitor close to the device from IN to GND to alleviate bus transients. The recommended input operating voltage range is 4.5 to 60 V. $V_{(OUT)}$, in the ON condition, is calculated using 方程式 4.

$$V_{(OUT)} = V_{(IN)} - (RON \times I_{(OUT)}) \quad (4)$$

Where,

- RON is the total ON resistance of the internal FETs.

GND pin must be connected to the system ground. RTN is the device ground reference for all the internal control blocks. Connect the TPS2662x family support components: $R_{(ILIM)}$, $C_{(dVdT)}$ and resistors for UVLO and OVP with respect to the RTN pin. Internally, the device has reverse input polarity protection block between RTN and the GND terminal. Connecting RTN pin to GND pin disables the reverse polarity protection feature and the TPS2662x gets permanently damaged when operated under this fault event.

9.3.9 Thermal Shutdown

The device has a built-in overtemperature shutdown circuitry designed to protect the internal FETs, if the junction temperature exceeds $T_{(TSD)}$. After the thermal shutdown event, depending upon the mode of fault response, the device either latches off or commences an auto-retry cycle 512 ms after $T_J < (T_{(TSD)} - 13.5^\circ\text{C})$. During the thermal shutdown, the fault pin \overline{FLT} pulls low to indicate a fault condition.

9.4 Device Functional Modes

9.4.1 Low Current Shutdown Control (\overline{SHDN})

The internal FETs and the load current can be switched off by pulling the \overline{SHDN} pin below 0.9-V threshold with a micro-controller GPIO pin or can be controlled remotely with an opto-isolator device as shown in [图 9-15](#) and [图 9-16](#). The device quiescent current reduces to 10 μA (typical) in SHUTDOWN state. To assert \overline{SHDN} low, the pull down must sink at least 10 μA at 400 mV. To enable the device, \overline{SHDN} must be pulled up to at least 1.8 V. After the device is enabled, the internal FETs turn on with dVdT mode.

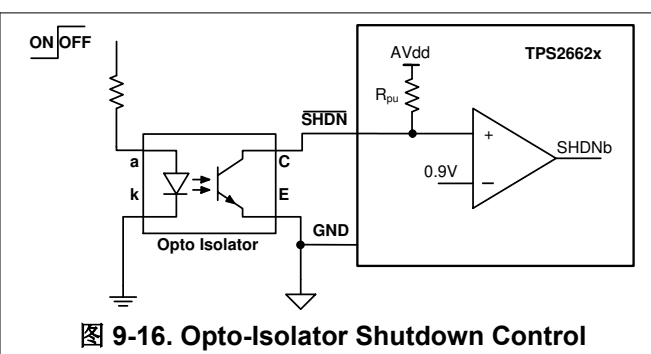
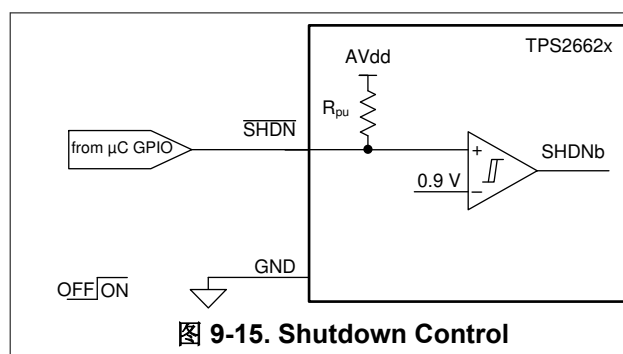

10 Application and Implementation

备注

以下应用部分中的信息不属于 TI 器件规格的范围，TI 不担保其准确性和完整性。TI 的客户应负责确定器件是否适用于其应用。客户应验证并测试其设计，以确保系统功能。

10.1 Application Information

The TPS2662x family is an industrial eFuse, typically used for Hot-Swap and power rail protection applications. The device operates from 4.5 V to 60 V with programmable current limit, overvoltage, undervoltage and reverse polarity protections. The device aids in controlling inrush current and provides robust protection against reverse current and field miss-wiring conditions for systems such as PLC I/O modules and sensor power supplies. The device also provides robust protection for multiple faults on the system rail.

The [Detailed Design Procedure](#) section can be used to select component values for the device.

Alternatively, the [WEBENCH®](#) software can be used to generate a complete design. The WEBENCH® software uses an iterative design procedure and accesses a comprehensive database of components when generating a design. Additionally, a spreadsheet design tool, [TPS2662 Design Calculator](#), is available in the web product folder.

10.2 Typical Application



图 10-1. 24-V, 500-mA eFuse Input Protection Circuit for PLC I/O Module

10.2.1 Design Requirements

表 10-1 shows the design requirements for TPS2662x.

表 10-1. Design Requirements

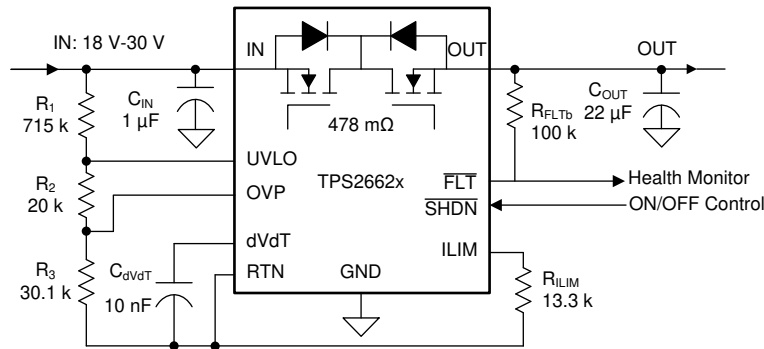
DESIGN PARAMETER		EXAMPLE VALUE
$V_{(IN)}$	Typical input voltage	24 V
$V_{(UV)}$	Undervoltage lockout set point	18 V
$V_{(OV)}$	Overvoltage cutoff set point	30 V
$T_{(SU)}$	Load during start-up	96 Ω
$I_{(LIM)}$	Current limit	500 mA
$C_{(OUT)}$	Load capacitance	22 μ F
T_A	Maximum ambient temperature	125°C

10.2.2 Detailed Design Procedure

10.2.2.1 Step-by-Step Design Procedure

To begin the design process, the designer must know the following parameters:

- Input operating voltage range
- Maximum output capacitance
- Maximum current limit
- Load during start-up
- Maximum ambient temperature

This design procedure below seeks to control junction temperature of the device in both steady state and start-up conditions by proper selection of the output ramp-up time and associated support components. The designer can adjust this procedure to fit the application and design criteria.

10.2.2.2 Programming the Current Limit Threshold $R_{(ILIM)}$ Selection

The $R_{(ILIM)}$ resistor at the ILIM pin sets the over load current limit. the current limit can be set using [方程式 5](#).

$$R_{ILIM} = \frac{6.636}{I_{LIM}} = 13.27 \text{ k}\Omega \quad (5)$$

where

- $I_{LIM} = 500 \text{ mA}$

Choose the closest standard 1% resistor value: $R_{(ILIM)} = 13.3 \text{ k}\Omega$.

10.2.2.3 Undervoltage Lockout and Overvoltage Set Point

The undervoltage lockout (UVLO) and overvoltage trip point are adjusted using an external voltage divider network of R_1 , R_2 and R_3 connected between IN, UVLO, OVP and RTN pins of the device. The values required for setting the undervoltage and overvoltage are calculated by solving [方程式 6](#) and [方程式 7](#).

$$V_{(OVPR)} = \frac{R_3}{R_1 + R_2 + R_3} \times V_{(OV)} \quad (6)$$

$$V_{(UVLOR)} = \frac{R_2 + R_3}{R_1 + R_2 + R_3} \times V_{(UV)} \quad (7)$$

For minimizing the input current drawn from the power supply $\{I_{(R123)} = V_{(IN)} / (R_1 + R_2 + R_3)\}$, TI recommends to use higher value resistance for R_1 , R_2 and R_3 .

However, the leakage current due to external active components connected at resistor string can add error to these calculations. So, the resistor string current, $I_{(R123)}$ must be chosen to be 20 times greater than the leakage current of UVLO and OVP pins.

From the device electrical specifications, $V_{(OVPR)} = 1.19 \text{ V}$ and $V_{(UVLOR)} = 1.19 \text{ V}$. From the design requirements, $V_{(OV)}$ is 30 V and $V_{(UV)}$ is 18 V. To solve the equation, first choose the value of $R_3 = 30.1 \text{ k}\Omega$ and use [方程式 6](#) to solve for $(R_1 + R_2) = 728.7 \text{ k}\Omega$. Use [方程式 7](#) and value of $(R_1 + R_2)$ to solve for $R_2 = 20.05 \text{ k}\Omega$ and finally $R_1 = 708.6 \text{ k}\Omega$.

Choose the closest standard 1% resistor values: $R_1 = 715 \text{ k}\Omega$, $R_2 = 20 \text{ k}\Omega$, and $R_3 = 30.1 \text{ k}\Omega$.

10.2.2.4 Setting Output Voltage Ramp Time—(t_{dVdT})

For a successful design, the junction temperature of the device must be kept below the absolute -maximum rating during dynamic (start-up) and steady state conditions. The dynamic power dissipation is often an order magnitude greater than the steady state power dissipation. It is important to determine the right start-up time and

the inrush current limit for the system to avoid thermal shutdown during start-up with and without load. The ramp-up capacitor C_{dVdT} is calculated considering the two possible cases:

10.2.2.4.1 Case 1: Start-Up Without Load—Only Output Capacitance $C_{(OUT)}$ Draws Current During Start-Up

During start-up, as the output capacitor charges, the voltage difference across the internal FET decreases, and the power dissipation decreases. Typical ramp-up of the output voltage, inrush current and instantaneous power dissipated in the device during start-up are shown in Figure 10-2. The average power dissipated in the device during start-up is equal to the area of triangular plot (red curve in Figure 10-3) averaged over t_{dVdT} .



图 10-2. Start-Up Without Load



图 10-3. $P_{D(INRUSH)}$ Due to Inrush Current

The inrush current is determined as shown in 方程式 8.

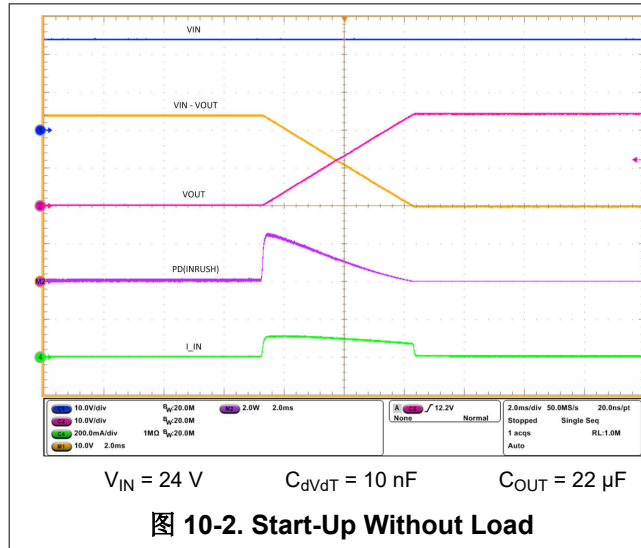
$$I = C \times \frac{dV}{dT} \geq I_{(INRUSH)} = C_{(OUT)} \times \frac{V_{(IN)}}{t_{dVdT}} \quad (8)$$

Average power dissipated during start-up is given by 方程式 9.

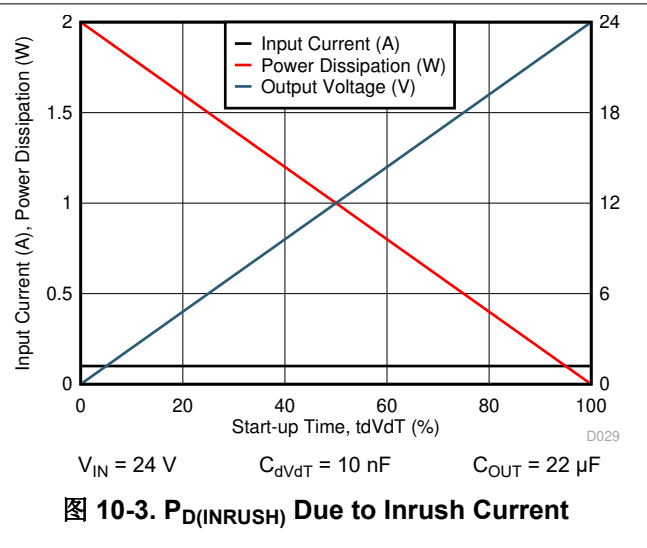
$$P_{D(INRUSH)} = 0.5 \times V_{(IN)} \times I_{(INRUSH)} \quad (9)$$

方程式 9 assumes that the load does not draw any current until the output voltage reaches its final value.

10.2.2.4.2 Case 2: Start-Up With Load—Output Capacitance $C_{(OUT)}$ and Load Draws Current During Start-Up

When the load draws current during the turn-on sequence, additional power is dissipated in the device. Considering a resistive load $R_L(SU)$ during start-up, typical ramp-up of output voltage, Figure 10-4 shows load current and the instantaneous power dissipation in the device. Figure 10-5 plots Instantaneous power dissipation with respect to time.

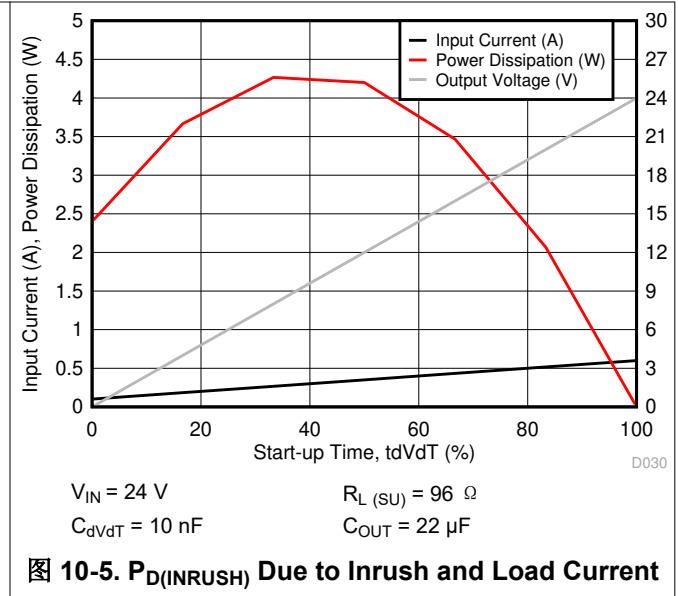
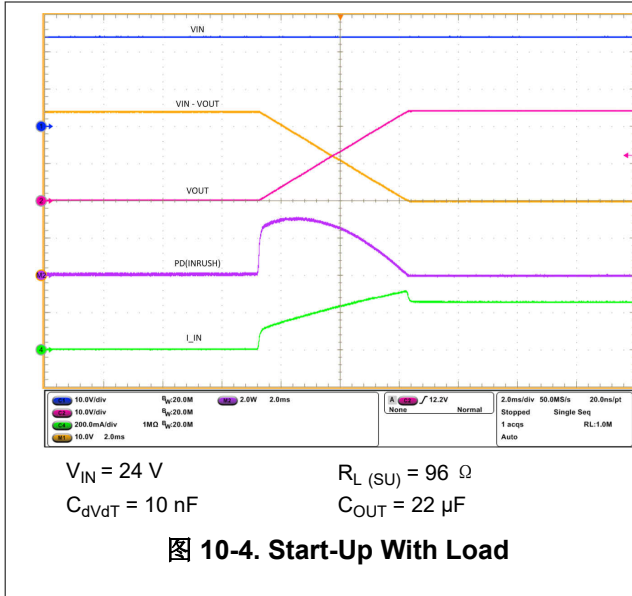

The additional power dissipation during start-up is calculated using 方程式 10.

$$PD(Load) = \frac{1}{6} \times \frac{V_{(IN)}^2}{R_L(SU)} \tag{10}$$

Total power dissipated in the device during start-up is given by 方程式 11.

$$PD(STARTUP) = PD(INRUSH) + PD(Load) \tag{11}$$

Total current during start-up is given by 方程式 12.

$$I(STARTUP) = I(INRUSH) + I_L(t) \tag{12}$$

For the design example under discussion,

Select the inrush current $I_{(INRUSH)} = 0.1\text{ A}$ and t_{dVdT} calculated using 方程式 8 is 5.28 ms.

For a given start-up time, C_{dVdT} capacitance value calculated using 方程式 2 is 10.7 nF for $t_{dVdT} = 5.28\text{ ms}$ and $V_{IN} = 24\text{ V}$.

Choose the closest standard value: 10.0 nF and 16-V capacitor.

The inrush power dissipation due to output capacitor alone is calculated using 方程式 9 and it is 1.2 W. Considering the start-up with 96-Ω load, the additional power dissipation calculated using 方程式 10 is 1 W. The total device power dissipation during start-up is 2.2 W

The power dissipation with or without load, for a selected start-up time must not exceed the thermal shutdown limits as shown in 图 10-6.

From the thermal shutdown limit graph, at $T_A = 125^\circ\text{C}$, thermal shutdown time for 2.2 W is close to 580 ms. It is safe to have a minimum 30% margin to allow for variation of the system parameters such as load, component tolerance, input voltage and layout. Selected 10-nF C_{dVdT} capacitor and 5.28-ms start-up time (t_{dVdT}) are well within the limit for successful start-up with 96-Ω load.

Higher value $C_{(dVdT)}$ capacitor can be selected to further reduce the power dissipation during start-up.



图 10-6. Thermal Shutdown Time vs Power Dissipation

10.2.2.4.3 Support Component Selections - R_{FLT} and $C_{(IN)}$

The R_{FLT} *Absolute Maximum Ratings* serves as pull-up for the open-drain fault output. The current sink by this pin must not exceed 10 mA (see the *Absolute Maximum Ratings* table). TI recommends typical resistance value in the range of 10 kΩ to 100 kΩ for R_{FLT} . The C_{IN} is a local bypass capacitor to suppress noise at the input. TI recommends typical capacitance value in the range of 0.1 μF to 1 μF for $C_{(IN)}$.

10.2.3 Application Curves

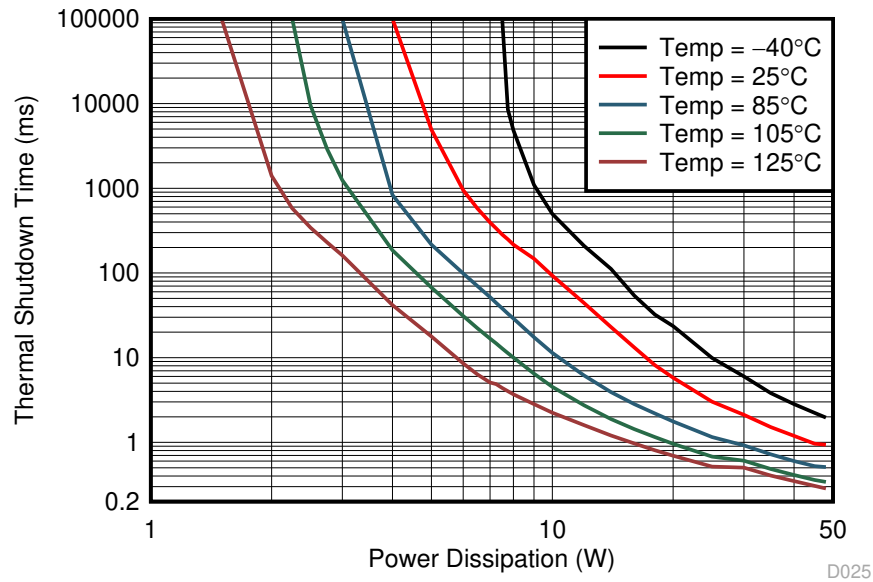

图 10-7. Hot Plug With VIN - No Load



图 10-8. Hot-Plug With VIN - 96-Ω Load

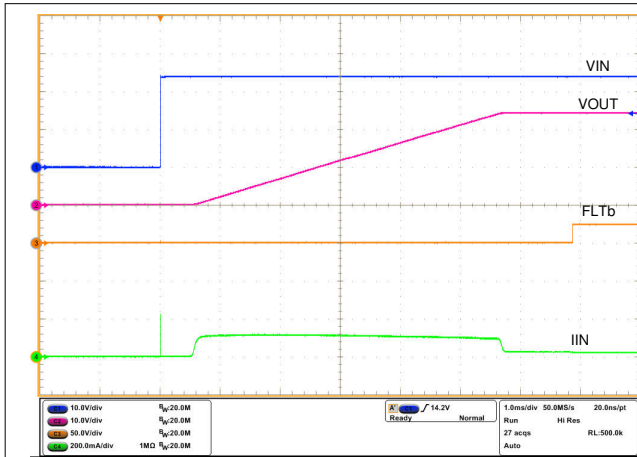

图 10-9. Start-Up With Shutdown Pin - 96-Ω Load

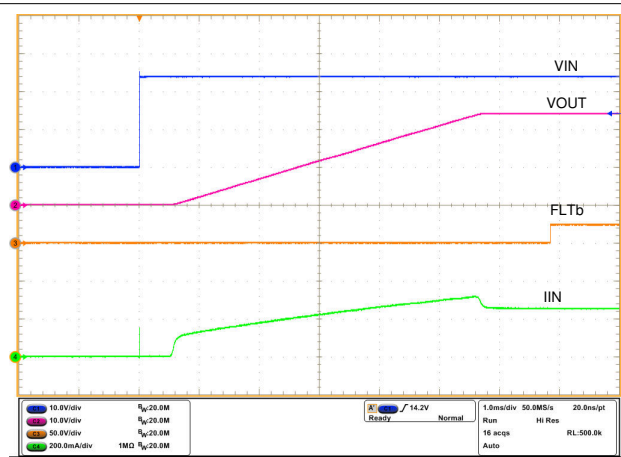

图 10-10. Power Down With Shutdown Pin - 96-Ω Load

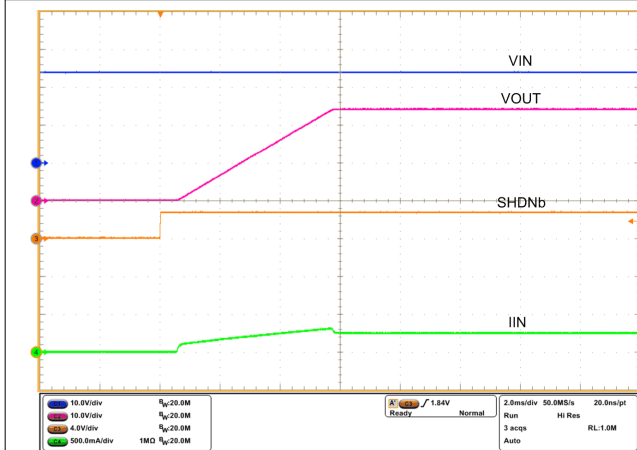

图 10-11. Over Load Response - Load Stepped From 136-Ω to 36-Ω Load

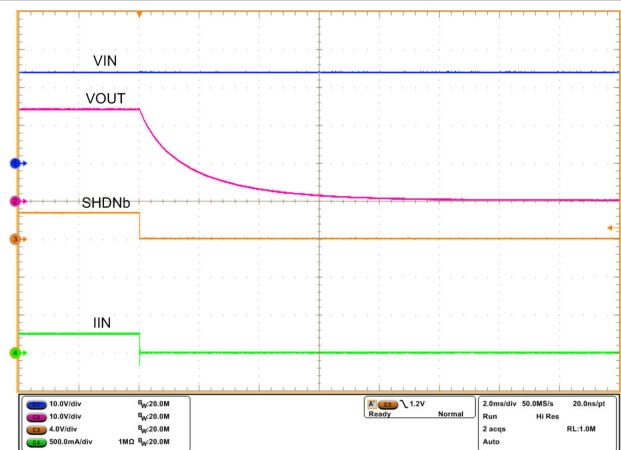

图 10-12. Turn ON With Short Circuit on Output

10.3 System Examples

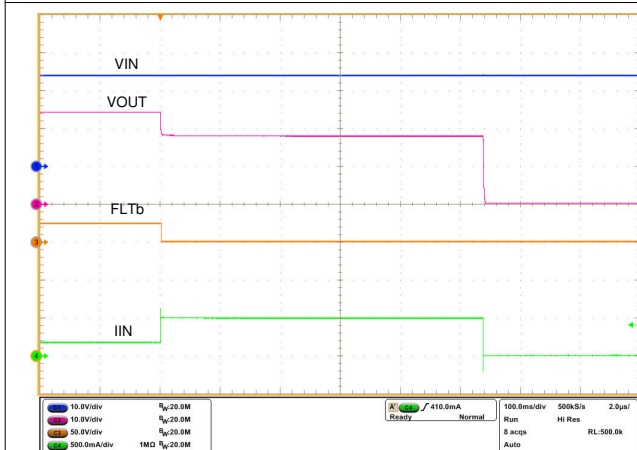
10.3.1 Field Supply Protection in PLC, DCS I/O Modules

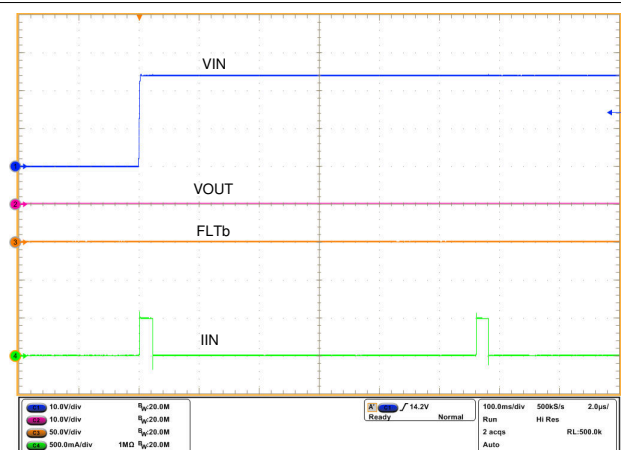

图 10-13. Power Delivery Circuit Block Diagram in I/O Modules

The PLC or Distributed Control System (DCS) I/O modules are often connected to an external field power supply to support higher power requirements of the field loads like sensors and actuators. Power-supply faults or miswiring can damage the loads or cause the loads not to operate correctly. The TPS26624 and TPS26625 can be used as a front end protection circuit to protect and provide stable supply to the field loads. Undervoltage, overvoltage, and input and output side reverse polarity protection features of these devices prevent the loads to experience voltages outside the operating range, which can permanently damage the loads.

Field power supply is often connected to multiple I/O modules that can deliver more current than a single I/O module can handle. Overcurrent protection scheme of the TPS2662x family limits the current from the power supply to the module so that the maximum current does not rise above what the board is designed for. Fast short-circuit protection scheme isolates the faulty load from the field supply quickly and prevents the field supply to dip and cause interrupts in the other I/O modules connected to the same field supply. High accurate ($\pm 5\%$ at 0.88 A) current limit facilitates more I/O modules to be connected to field supply. Fault indication (FLT) features facilitate continuous load monitoring.

The TPS26624 and TPS26625 also acts as a smart diode with protection against reverse current during output side miswiring. Reverse current can potentially damage the field power supply and cause the I/O modules to run hot or can cause permanent damage.

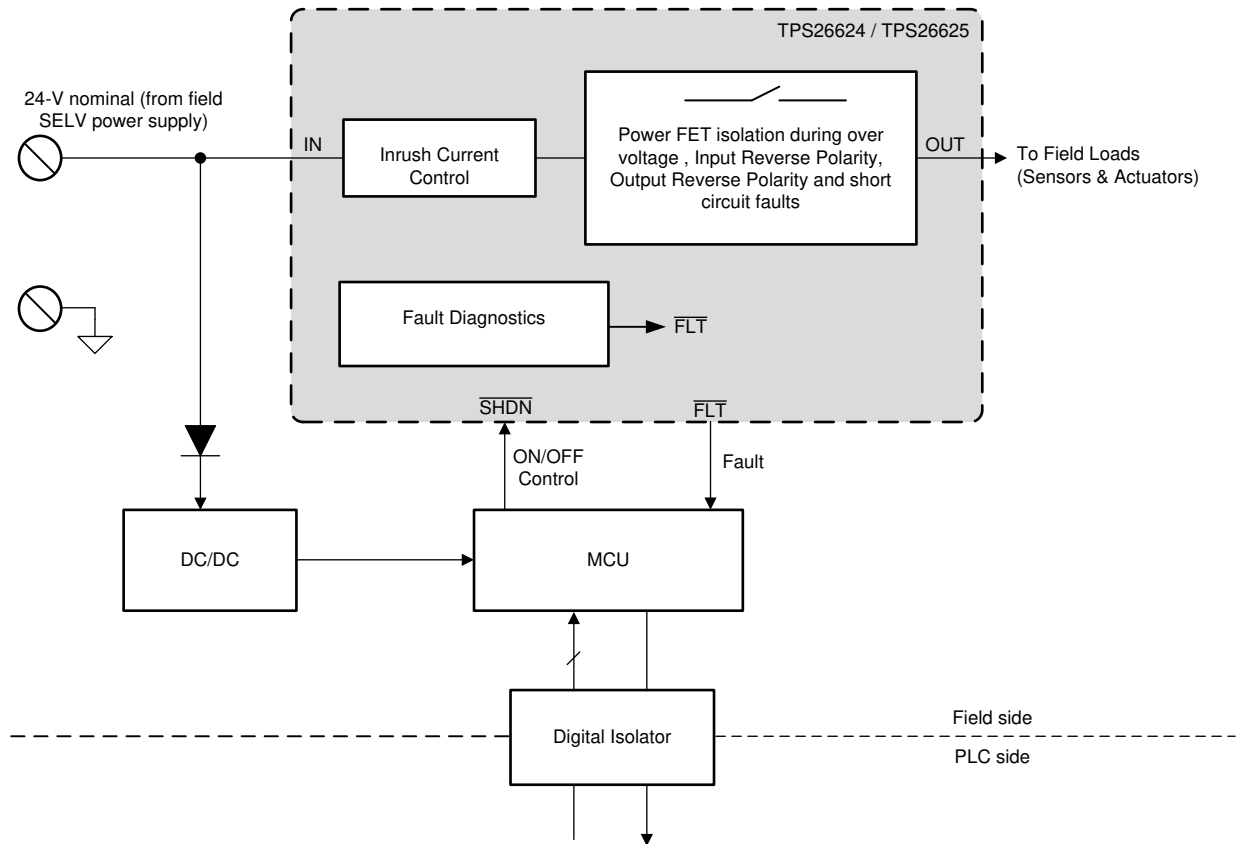
If the field power supply is connected in reverse polarity on the input side (which is not unlikely as field power supplies are usually connected with screw terminals), field loads can permanently get damaged due to the reverse voltage. Also, during the installation the field power supply can be miswired on the output side instead of on the input side which can damage the upstream power supply and electronics. The input and output reverse polarity protection feature of the TPS26624 and TPS26625 prevents the reverse voltage to appear at the load side as well as supply side offering complete system protection during field miswiring.

10.3.2 Simple 24-V Power Supply Path Protection

With the TPS2662x, a simple 24-V power supply path protection can be realized using a minimum of four external components as shown in the schematic diagram in 图 10-14. The external components required are: a 1Meg Ω $R_{(1)}$ resistor across IN and UVLO pins, a $R_{(ILIM)}$ resistor to program the current limit, $C_{(IN)}$ and $C_{(OUT)}$ capacitors.



图 10-14. TPS2662x Configured for a Simple 24-V Supply Path Protection

Protection features with this configuration include:

- Load and device protection from reverse input polarity fault down to - 60 V
- Upstream supply and device protection from reverse output polarity fault down to - (60 - VIN) V with TPS26624 and TPS26625 variants
- Protection from 60 V from the external SELV supply: overvoltage Clamp at 38 V with TPS26622 and TPS26623 variants
- Inrush current control with 24 V and 660- μ s output voltage slew rate
- Reverse Current Blocking
- Accurate current limiting with auto-retry with TPS26621, TPS26623, TPS26625 variants
- Accurate current limiting with latch-off with TPS26620, TPS26622, TPS26624 variants

10.3.3 Power Stealing in Smart Thermostat

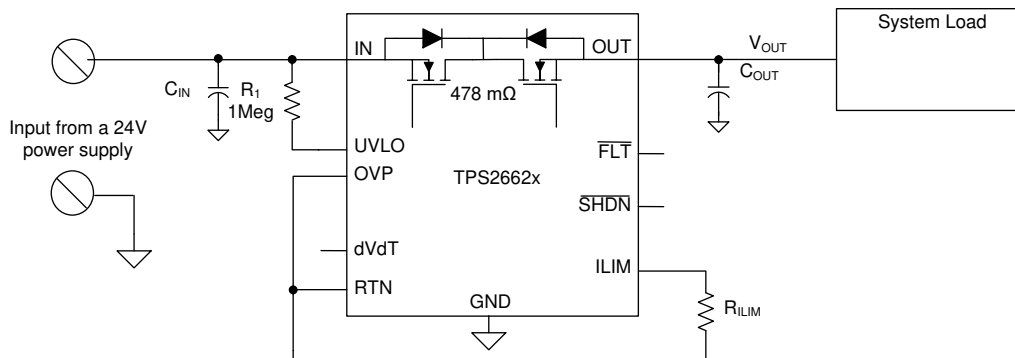
The adjustable protection features of the TPS2662x eFuse, like the inrush current limiting, overvoltage and overcurrent protection, simplifies the input power management design in smart thermostats. Refer to the TI Design report, [Power Stage Reference Design for Power Stealing Thermostat](#), for further information.

10.4 Do's and Don'ts

- Do not connect RTN to GND. Connecting RTN to GND disables the Reverse Polarity protection feature.
- Do connect the TPS2662x support components $R_{(ILIM)}$, $C_{(dVdT)}$, and UVLO, OVP resistors with respect to RTN pin.
- Do connect device PowerPAD to the RTN plane for an enhanced thermal performance.

11 Power Supply Recommendations

The TPS2662x eFuse is designed for the supply voltage range of $4.5\text{ V} \leq V_{\text{IN}} \leq 60\text{ V}$. If the input supply is located more than a few inches from the device, TI recommends an input ceramic bypass capacitor higher than $0.1\ \mu\text{F}$. Power supply must be rated higher than the current limit set to avoid voltage droops during overcurrent and short-circuit conditions.

11.1 Transient Protection

In case of short circuit and over load current limit, when the device interrupts current flow, input inductance generates a positive voltage spike on the input and output inductance generates a negative voltage spike on the output. The peak amplitude of voltage spikes (transients) depends on the value of inductance in series to the input or output of the device. These transients can exceed the *Absolute Maximum Ratings* of the device if steps are not taken to address the issue.

Typical methods for addressing transients include:

- Minimizing lead length and inductance into and out of the device
- Using large PCB GND plane
- Use of a Schottky diode across the output and GND to absorb negative spikes in the designs with TPS26620, TPS26621, TPS26622, TPS26623 devices and a TVS clamp in the designs with TPS26624 and TPS26625 devices
- A low value ceramic capacitor (C_{IN}) to approximately $0.1\ \mu\text{F}$) to absorb the energy and dampen the transients.

The approximate value of input capacitance can be estimated with [方程式 13](#).

$$V_{\text{spike(Absolute)}} = V_{\text{(IN)}} + I_{\text{(Load)}} \times \sqrt{\frac{L_{\text{(IN)}}}{C_{\text{(IN)}}}} \quad (13)$$

where

- $V_{\text{(IN)}}$ is the nominal supply voltage
- $I_{\text{(LOAD)}}$ is the load current
- $L_{\text{(IN)}}$ equals the effective inductance seen looking into the source
- $C_{\text{(IN)}}$ is the capacitance present at the input

Some applications can require additional Transient Voltage Suppressor (TVS) to prevent transients from exceeding the *Absolute Maximum Ratings* of the device. These transients can occur during positive and negative surge tests on the supply lines. In such applications TI recommends to place at least $1\ \mu\text{F}$ of input capacitor to limit the falling slew rate of the input voltage within a maximum of $20\text{ V}/\mu\text{s}$.

The circuit implementation with optional protection components (a ceramic capacitor, TVS and Schottky diode) is shown in [Figure 11-1](#) and [Figure 11-2](#).

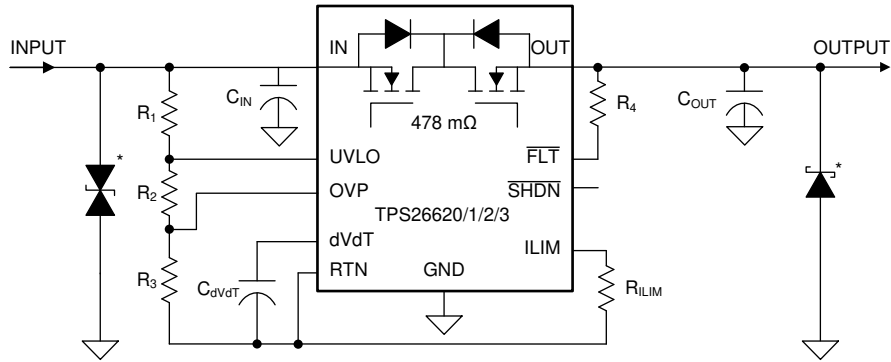

* Optional components needed for suppression of transients

图 11-1. Circuit Implementation With Optional Protection Components for TPS26620, TPS26621, TPS26622, and TPS26623

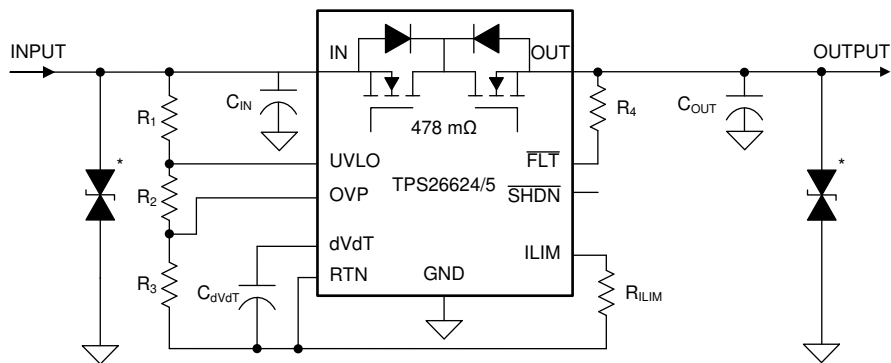

* Optional components needed for suppression of transients

图 11-2. Circuit Implementation With Optional Protection Components for TPS26624 and TPS26625

12 Layout

12.1 Layout Guidelines

- For all the applications, TI recommends a 0.1 μF or higher value ceramic decoupling capacitor between IN terminal and GND.
- The optimum placement of decoupling capacitor is closest to the IN and GND terminals of the device. Care must be taken to minimize the loop area formed by the bypass-capacitor connection, the IN terminal, and the GND terminal of the IC. See [Figure 12-1](#) for a typical PCB layout example.
- High current carrying power path connections must be as short as possible and must be sized to carry at least twice the full-load current.
- RTN, which is the reference ground for the device must be a copper plane or island.
- Locate all the TPS2662x family support components $R_{(\text{ILIM})}$, $C_{(\text{dVdT})}$, UVLO, OVP resistors close to their connection pin. Connect the other end of the component to the RTN with shortest trace length.
- The trace routing for the R_{ILIM} component to the device must be as short as possible to reduce parasitic effects on the current limit and current monitoring accuracy. These traces must not have any coupling to switching signals on the board.
- Protection devices such as TVS, snubbers, capacitors, or diodes must be placed physically close to the device they are intended to protect, and routed with short traces to reduce inductance. For example, TI recommends a protection Schottky diode to address negative transients due to switching of inductive loads, and it must be physically close to the OUT and GND pins.
- Thermal considerations: when properly mounted, the PowerPAD package provides significantly greater cooling ability. To operate at rated power, the PowerPAD must be soldered directly to the board RTN plane directly under the device. Other planes, such as the bottom side of the circuit board can be used to increase heat sinking in higher current applications. Designs that do not need reverse input polarity protection can have RTN, GND and PowerPAD connected together. PowerPAD in these designs can be connected to the PCB ground plane.

12.2 Layout Example

-  Top Layer
-  Bottom layer GND plane
-  Top Layer RTN Plane
-  Bottom Layer RTN Plane
-  Via to Bottom Layer
-  Track in bottom layer



图 12-1. Typical PCB Layout Example With a 2 Layer PCB

13 Device and Documentation Support

13.1 Documentation Support

13.1.1 Related Documentation

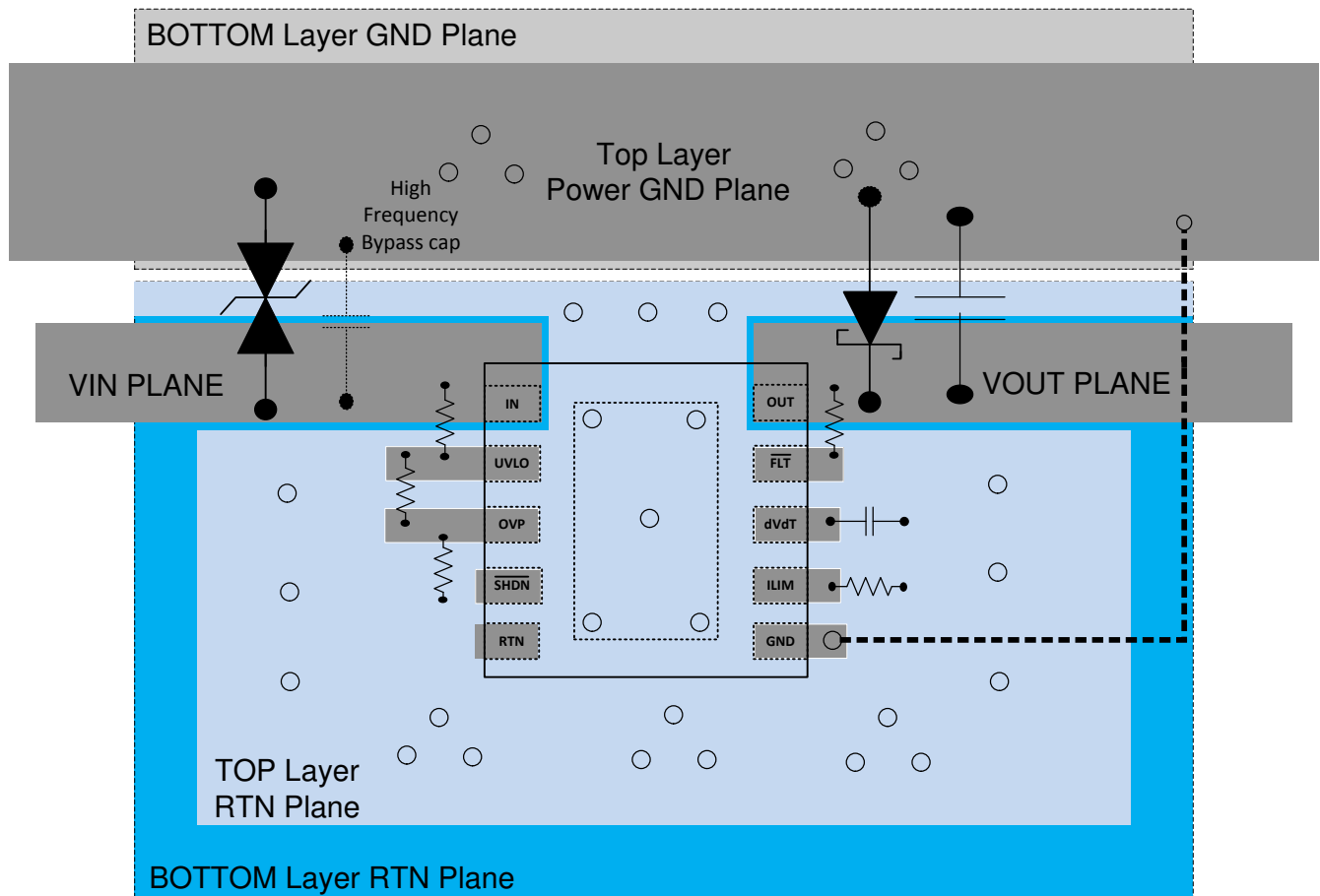
- Texas Instruments, [Power Stage Reference Design for Power Stealing Thermostat design guide](#)

13.2 接收文档更新通知

要接收文档更新通知，请导航至 ti.com 上的器件产品文件夹。点击 [订阅更新](#) 进行注册，即可每周接收产品信息更改摘要。有关更改的详细信息，请查看任何已修订文档中包含的修订历史记录。

13.3 支持资源

[TI E2E™ 支持论坛](#) 是工程师的重要参考资料，可直接从专家获得快速、经过验证的解答和设计帮助。搜索现有解答或提出自己的问题可获得所需的快速设计帮助。

链接的内容由各个贡献者“按原样”提供。这些内容并不构成 TI 技术规范，并且不一定反映 TI 的观点；请参阅 TI 的《[使用条款](#)》。

13.4 Trademarks

PowerPAD™ and TI E2E™ are trademarks of Texas Instruments.

WEBENCH® is a registered trademark of Texas Instruments.

所有商标均为其各自所有者的财产。

13.5 Electrostatic Discharge Caution



This integrated circuit can be damaged by ESD. Texas Instruments recommends that all integrated circuits be handled with appropriate precautions. Failure to observe proper handling and installation procedures can cause damage.

ESD damage can range from subtle performance degradation to complete device failure. Precision integrated circuits may be more susceptible to damage because very small parametric changes could cause the device not to meet its published specifications.

13.6 术语表

[TI 术语表](#) 本术语表列出并解释了术语、首字母缩略词和定义。

14 Mechanical, Packaging, and Orderable Information

The following pages include mechanical, packaging, and orderable information. This information is the most current data available for the designated devices. This data is subject to change without notice and revision of this document. For browser-based versions of this data sheet, refer to the left-hand navigation.

PACKAGING INFORMATION

Orderable Device	Status (1)	Package Type	Package Drawing	Pins	Package Qty	Eco Plan (2)	Lead finish/ Ball material (6)	MSL Peak Temp (3)	Op Temp (°C)	Device Marking (4/5)	Samples
TPS26620DRCR	ACTIVE	VSON	DRC	10	3000	RoHS & Green	NIPDAU	Level-2-260C-1 YEAR	-40 to 125	ED00	Samples
TPS26620DRCT	ACTIVE	VSON	DRC	10	250	RoHS & Green	NIPDAU	Level-2-260C-1 YEAR	-40 to 125	ED00	Samples
TPS26621DRCR	ACTIVE	VSON	DRC	10	3000	RoHS & Green	NIPDAU	Level-1-260C-UNLIM	-40 to 125	ED01	Samples
TPS26621DRCT	ACTIVE	VSON	DRC	10	250	RoHS & Green	NIPDAU	Level-1-260C-UNLIM	-40 to 125	ED01	Samples
TPS26622DRCR	ACTIVE	VSON	DRC	10	3000	RoHS & Green	NIPDAU	Level-1-260C-UNLIM	-40 to 125	ED02	Samples
TPS26622DRCT	ACTIVE	VSON	DRC	10	250	RoHS & Green	NIPDAU	Level-1-260C-UNLIM	-40 to 125	ED02	Samples
TPS26623DRCR	ACTIVE	VSON	DRC	10	3000	RoHS & Green	NIPDAU	Level-1-260C-UNLIM	-40 to 125	ED03	Samples
TPS26623DRCT	ACTIVE	VSON	DRC	10	250	RoHS & Green	NIPDAU	Level-1-260C-UNLIM	-40 to 125	ED03	Samples
TPS26624DRCR	ACTIVE	VSON	DRC	10	3000	RoHS & Green	NIPDAU	Level-1-260C-UNLIM	-40 to 125	ED04	Samples
TPS26624DRCT	ACTIVE	VSON	DRC	10	250	RoHS & Green	NIPDAU	Level-1-260C-UNLIM	-40 to 125	ED04	Samples
TPS26625DRCR	ACTIVE	VSON	DRC	10	3000	RoHS & Green	NIPDAU	Level-1-260C-UNLIM	-40 to 125	ED05	Samples
TPS26625DRCT	ACTIVE	VSON	DRC	10	250	RoHS & Green	NIPDAU	Level-1-260C-UNLIM	-40 to 125	ED05	Samples

(1) The marketing status values are defined as follows:

ACTIVE: Product device recommended for new designs.

LIFEBUY: TI has announced that the device will be discontinued, and a lifetime-buy period is in effect.

NRND: Not recommended for new designs. Device is in production to support existing customers, but TI does not recommend using this part in a new design.

PREVIEW: Device has been announced but is not in production. Samples may or may not be available.

OBSOLETE: TI has discontinued the production of the device.

(2) **RoHS:** TI defines "RoHS" to mean semiconductor products that are compliant with the current EU RoHS requirements for all 10 RoHS substances, including the requirement that RoHS substance do not exceed 0.1% by weight in homogeneous materials. Where designed to be soldered at high temperatures, "RoHS" products are suitable for use in specified lead-free processes. TI may reference these types of products as "Pb-Free".

RoHS Exempt: TI defines "RoHS Exempt" to mean products that contain lead but are compliant with EU RoHS pursuant to a specific EU RoHS exemption.

Green: TI defines "Green" to mean the content of Chlorine (Cl) and Bromine (Br) based flame retardants meet JS709B low halogen requirements of <=1000ppm threshold. Antimony trioxide based flame retardants must also meet the <=1000ppm threshold requirement.

- (3) MSL, Peak Temp. - The Moisture Sensitivity Level rating according to the JEDEC industry standard classifications, and peak solder temperature.
- (4) There may be additional marking, which relates to the logo, the lot trace code information, or the environmental category on the device.
- (5) Multiple Device Markings will be inside parentheses. Only one Device Marking contained in parentheses and separated by a "~" will appear on a device. If a line is indented then it is a continuation of the previous line and the two combined represent the entire Device Marking for that device.
- (6) Lead finish/Ball material - Orderable Devices may have multiple material finish options. Finish options are separated by a vertical ruled line. Lead finish/Ball material values may wrap to two lines if the finish value exceeds the maximum column width.

Important Information and Disclaimer:The information provided on this page represents TI's knowledge and belief as of the date that it is provided. TI bases its knowledge and belief on information provided by third parties, and makes no representation or warranty as to the accuracy of such information. Efforts are underway to better integrate information from third parties. TI has taken and continues to take reasonable steps to provide representative and accurate information but may not have conducted destructive testing or chemical analysis on incoming materials and chemicals. TI and TI suppliers consider certain information to be proprietary, and thus CAS numbers and other limited information may not be available for release.

In no event shall TI's liability arising out of such information exceed the total purchase price of the TI part(s) at issue in this document sold by TI to Customer on an annual basis.

TAPE AND REEL INFORMATION

QUADRANT ASSIGNMENTS FOR PIN 1 ORIENTATION IN TAPE

*All dimensions are nominal

Device	Package Type	Package Drawing	Pins	SPQ	Reel Diameter (mm)	Reel Width W1 (mm)	A0 (mm)	B0 (mm)	K0 (mm)	P1 (mm)	W (mm)	Pin1 Quadrant
TPS26620DRCR	VSON	DRC	10	3000	330.0	12.4	3.3	3.3	1.1	8.0	12.0	Q2
TPS26620DRCT	VSON	DRC	10	250	180.0	12.4	3.3	3.3	1.1	8.0	12.0	Q2
TPS26621DRCR	VSON	DRC	10	3000	330.0	12.4	3.3	3.3	1.1	8.0	12.0	Q2
TPS26621DRCT	VSON	DRC	10	250	180.0	12.4	3.3	3.3	1.1	8.0	12.0	Q2
TPS26622DRCR	VSON	DRC	10	3000	330.0	12.4	3.3	3.3	1.1	8.0	12.0	Q2
TPS26622DRCT	VSON	DRC	10	250	180.0	12.4	3.3	3.3	1.1	8.0	12.0	Q2
TPS26623DRCR	VSON	DRC	10	3000	330.0	12.4	3.3	3.3	1.1	8.0	12.0	Q2
TPS26623DRCT	VSON	DRC	10	250	180.0	12.4	3.3	3.3	1.1	8.0	12.0	Q2
TPS26624DRCR	VSON	DRC	10	3000	330.0	12.4	3.3	3.3	1.1	8.0	12.0	Q2
TPS26624DRCT	VSON	DRC	10	250	180.0	12.4	3.3	3.3	1.1	8.0	12.0	Q2
TPS26625DRCR	VSON	DRC	10	3000	330.0	12.4	3.3	3.3	1.1	8.0	12.0	Q2
TPS26625DRCT	VSON	DRC	10	250	180.0	12.4	3.3	3.3	1.1	8.0	12.0	Q2

TAPE AND REEL BOX DIMENSIONS

*All dimensions are nominal

Device	Package Type	Package Drawing	Pins	SPQ	Length (mm)	Width (mm)	Height (mm)
TPS26620DRCR	VSON	DRC	10	3000	367.0	367.0	35.0
TPS26620DRCT	VSON	DRC	10	250	210.0	185.0	35.0
TPS26621DRCR	VSON	DRC	10	3000	367.0	367.0	35.0
TPS26621DRCT	VSON	DRC	10	250	210.0	185.0	35.0
TPS26622DRCR	VSON	DRC	10	3000	367.0	367.0	35.0
TPS26622DRCT	VSON	DRC	10	250	210.0	185.0	35.0
TPS26623DRCR	VSON	DRC	10	3000	367.0	367.0	35.0
TPS26623DRCT	VSON	DRC	10	250	210.0	185.0	35.0
TPS26624DRCR	VSON	DRC	10	3000	367.0	367.0	35.0
TPS26624DRCT	VSON	DRC	10	250	210.0	185.0	35.0
TPS26625DRCR	VSON	DRC	10	3000	367.0	367.0	35.0
TPS26625DRCT	VSON	DRC	10	250	210.0	185.0	35.0

GENERIC PACKAGE VIEW

DRC 10

VSON - 1 mm max height

3 x 3, 0.5 mm pitch

PLASTIC SMALL OUTLINE - NO LEAD

This image is a representation of the package family, actual package may vary.
Refer to the product data sheet for package details.



4226193/A

EXAMPLE BOARD LAYOUT

DRC0010J

VSON - 1 mm max height

PLASTIC SMALL OUTLINE - NO LEAD



LAND PATTERN EXAMPLE
EXPOSED METAL SHOWN
SCALE:20X



SOLDER MASK DETAILS

4218878/B 07/2018

NOTES: (continued)

4. This package is designed to be soldered to a thermal pad on the board. For more information, see Texas Instruments literature number SLUA271 (www.ti.com/lit/slua271).
5. Vias are optional depending on application, refer to device data sheet. If any vias are implemented, refer to their locations shown on this view. It is recommended that vias under paste be filled, plugged or tented.

EXAMPLE STENCIL DESIGN

DRC0010J

VSON - 1 mm max height

PLASTIC SMALL OUTLINE - NO LEAD



SOLDER PASTE EXAMPLE
BASED ON 0.125 mm THICK STENCIL

EXPOSED PAD 11:
80% PRINTED SOLDER COVERAGE BY AREA
SCALE:25X

4218878/B 07/2018

NOTES: (continued)

6. Laser cutting apertures with trapezoidal walls and rounded corners may offer better paste release. IPC-7525 may have alternate design recommendations.

重要声明和免责声明

TI“按原样”提供技术和可靠性数据（包括数据表）、设计资源（包括参考设计）、应用或其他设计建议、网络工具、安全信息和其他资源，不保证没有瑕疵且不做任何明示或暗示的担保，包括但不限于对适销性、某特定用途方面的适用性或不侵犯任何第三方知识产权的暗示担保。

这些资源可供使用 TI 产品进行设计的熟练开发人员使用。您将自行承担以下全部责任：(1) 针对您的应用选择合适的 TI 产品，(2) 设计、验证并测试您的应用，(3) 确保您的应用满足相应标准以及任何其他功能安全、信息安全、监管或其他要求。

这些资源如有变更，恕不另行通知。TI 授权您仅可将这些资源用于研发本资源所述的 TI 产品的应用。严禁对这些资源进行其他复制或展示。您无权使用任何其他 TI 知识产权或任何第三方知识产权。您应全额赔偿因在这些资源的使用中对 TI 及其代表造成的任何索赔、损害、成本、损失和债务，TI 对此概不负责。

TI 提供的产品受 [TI 的销售条款](#) 或 [ti.com](#) 上其他适用条款/TI 产品随附的其他适用条款的约束。TI 提供这些资源并不会扩展或以其他方式更改 TI 针对 TI 产品发布的适用的担保或担保免责声明。

TI 反对并拒绝您可能提出的任何其他或不同的条款。

邮寄地址：Texas Instruments, Post Office Box 655303, Dallas, Texas 75265

Copyright © 2022，德州仪器 (TI) 公司