

OPA454 High-Voltage (100-V), High-Current (50-mA) Operational Amplifiers, G = 1 Stable

1 Features

- Wide Power-Supply Range: ± 5 V (10 V) to ± 50 V (100 V)
- High-Output Load Drive: $I_O > \pm 50$ mA
- Wide Output Voltage Swing: 1 V to Rails
- Independent Output Disable or Shutdown
- Wide Temperature Range: -40°C to $+85^\circ\text{C}$
- 8-Pin SO Package

2 Applications

- Test Equipment
- Avalanche Photodiode: High-V Current Sense
- Piezoelectric Cells
- Transducer Drivers
- Servo Drivers
- Audio Amplifiers
- High-Voltage Compliance Current Sources
- General High-Voltage Regulators and Power

Simplified Pin Description

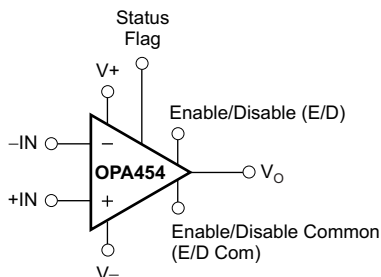

3 Description

The OPA454 device is a low-cost operational amplifier with high voltage (100 V) and relatively high current drive (50 mA). It is unity-gain stable and has a gain-bandwidth product of 2.5 MHz.

The OPA454 is internally protected against overtemperature conditions and current overloads. It is fully specified to perform over a wide power-supply range of ± 5 V to ± 50 V or on a single supply of 10 V to 100 V. The status flag is an open-drain output that allows it to be easily referenced to standard low-voltage logic circuitry. This high-voltage operational amplifier provides excellent accuracy, wide output swing, and is free from phase inversion problems that are often found in similar amplifiers.

The output can be independently disabled using the Enable or Disable Pin that has its own common return pin to allow easy interface to low-voltage logic circuitry. This disable is accomplished without disturbing the input signal path, not only saving power but also protecting the load.

Featured in a small exposed metal pad package, the OPA454 is easy to heatsink over the extended industrial temperature range, -40°C to $+85^\circ\text{C}$.

Device Information⁽¹⁾

PART NUMBER	PACKAGE	BODY SIZE (NOM)
OPA454	SO PowerPAD™ (8)	4.89 mm x 3.90 mm

(1) For all available packages, see the orderable addendum at the end of the data sheet.



Table of Contents

1 Features	1	10 Application and Implementation	22
2 Applications	1	10.1 Applications Information	22
3 Description	1	10.2 Typical Application	24
4 Revision History	2	10.3 System Examples	27
5 Device Comparison Table	3	11 Power Supply Recommendations	33
6 Pin Configuration and Functions	3	12 Layout	33
7 Specifications	4	12.1 Layout Guidelines	33
7.1 Absolute Maximum Ratings	4	12.2 Layout Example	35
7.2 ESD Ratings	4	12.3 Thermal Protection	36
7.3 Recommended Operating Conditions	4	12.4 Power Dissipation	36
7.4 Thermal Information	4	12.5 Heatsinking	37
7.5 Electrical Characteristics: $V_S = \pm 50\text{ V}$	5	13 Device and Documentation Support	38
7.6 Typical Characteristics	7	13.1 Device Support	38
8 Parameter Measurement Information	16	13.2 Documentation Support	38
9 Detailed Description	17	13.3 Community Resources	39
9.1 Overview	17	13.4 Trademarks	39
9.2 Functional Block Diagram	17	13.5 Electrostatic Discharge Caution	39
9.3 Feature Description	18	13.6 Glossary	39
9.4 Device Functional Modes	21	14 Mechanical, Packaging, and Orderable Information	39

4 Revision History

Changes from Revision A (December 2008) to Revision B	Page
• Added <i>Pin Functions</i> table, <i>ESD Ratings</i> table, <i>Recommended Operating Conditions</i> table, <i>Thermal Information</i> table, <i>Feature Description</i> section, <i>Device Functional Modes</i> section, <i>Application and Implementation</i> section, <i>Power Supply Recommendations</i> section, <i>Layout</i> section, <i>Device and Documentation Support</i> section, and <i>Mechanical, Packaging, and Orderable Information</i> section	1
• Changed <i>OPA454 Related Products</i> table to <i>Device Comparison</i> table	3
• Deleted <i>Ordering Information</i> table	3
• Corrected symbol error in <i>Absolute Maximum Ratings</i> table; changed <i>operating temperature</i> specification from T_J to T_A	4
• Changed Figure 29 title from <i>THD+N vs Temperature</i> to <i>THD+N vs Frequency</i>	10
• Changed Figure 30 title from <i>THD+N vs Temperature</i> to <i>THD+N vs Frequency</i>	10

Changes from Original (December 2007) to Revision A	Page
• Deleted <i>DDA Package</i> from title of Figure 13	9
• Deleted <i>DDA Package</i> from title of Figure 14	9
• Corrected mislabeled y-axis in Figure 42	12
• Corrected mislabeled y-axis in Figure 43	13
• Corrected mislabeled y-axis in Figure 44	13
• Changed statement about thermal shutdown cycling qualification studies from 400 hours to 1000 hours in <i>Current Limit</i> section	21
• Deleted <i>Top-Side PowerPAD Package</i> section	33
• Added alternate units (.013 in, or 0.3302 mm) for measurement of recommended through-hole diameter to <i>PowerPAD Layout Guidelines</i> description	34

5 Device Comparison Table

PRODUCT	DESCRIPTION
OPA445 ⁽¹⁾	80 V, 15 mA
OPA452	80 V, 50 mA
OPA547	60 V, 750 mA
OPA548	60 V, 3 A
OPA549	60 V, 9 A
OPA551	60 V, 200 mA
OPA567	5 V, 2 A
OPA569	5 V, 2.4 A

- (1) The OPA445 is pin-compatible with the OPA454, except in applications using the offset trim, and NC pins other than open.

6 Pin Configuration and Functions

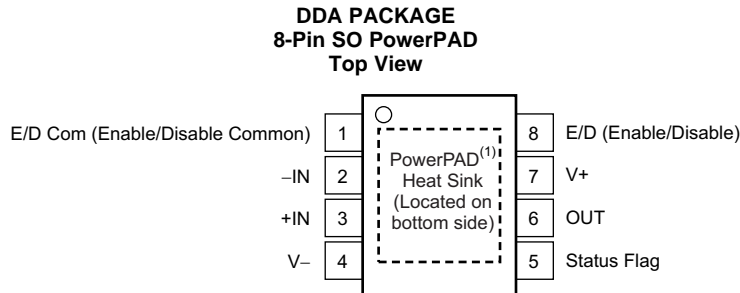

- (1) PowerPAD is internally connected to V-. Soldering the PowerPAD to the printed-circuit board (PCB) is always required, even with applications that have low power dissipation.

Pin Functions

PIN		I/O	DESCRIPTION
NAME	NO.		
E/D (Enable/Disable)	8	I	Enable/Disable
E/D Com	1	I	Enable/Disable common
-IN	2	I	Inverting input
+IN	3	I	Noninverting input
OUT	6	O	Output
Status Flag	5	O	The Status Flag is an open-drain active-low output referenced to E/D Com. This pin goes active for either an overcurrent or overtemperature condition.
V-	4	—	Negative (lowest) power supply
V+	7	—	Positive (highest) power supply

7 Specifications

7.1 Absolute Maximum Ratings

over operating free-air temperature range (unless otherwise noted)⁽¹⁾

		MIN	MAX	UNIT
Voltage	Supply voltage, $V_S = (V+) - (V-)$		120	V
	Signal input pin ⁽²⁾	$(V-) - 0.3$	$(V+) + 0.3$	V
	E/D to E/D Com		5.5	V
Current	Signal input pin ⁽²⁾		± 10	mA
	Output short circuit ⁽³⁾		Continuous	
Temperature	Operating, T_A	-55	125	°C
	Junction, T_J		150	°C
	Storage, T_{stg}	-55	125	°C

- (1) Stresses beyond those listed under *Absolute Maximum Ratings* may cause permanent damage to the device. These are stress ratings only, which do not imply functional operation of the device at these or any other conditions beyond those indicated under *Recommended Operating Conditions*. Exposure to absolute-maximum-rated conditions for extended periods may affect device reliability.
- (2) Input terminals are diode-clamped to the power-supply rails. Input signals that can swing more than 0.3 V beyond the supply rails must be current-limited to 10 mA or less.
- (3) Short-circuit to ground.

7.2 ESD Ratings

		VALUE	UNIT
$V_{(ESD)}$ Electrostatic discharge	Human-body model (HBM), per ANSI/ESDA/JEDEC JS-001 ⁽¹⁾	± 4000	V
	Charged-device model (CDM), per JEDEC specification JESD22-C101 ⁽²⁾	± 500	
	Machine model (MM)	± 150	

- (1) JEDEC document JEP155 states that 500-V HBM allows safe manufacturing with a standard ESD control process.
- (2) JEDEC document JEP157 states that 250-V CDM allows safe manufacturing with a standard ESD control process.

7.3 Recommended Operating Conditions

over operating free-air temperature range (unless otherwise noted)

		MIN	NOM	MAX	UNIT
	Supply voltage, $V_S = (V+) - (V-)$	10 (± 5)		100 (± 50)	V
T_A	Operating temperature	-55		125	°C

7.4 Thermal Information

THERMAL METRIC ⁽¹⁾		OPA454	UNIT
		DDA (SO)	
		8 PINS	
$R_{\theta JA}$	Junction-to-ambient thermal resistance	40.6	°C/W
$R_{\theta JC(top)}$	Junction-to-case (top) thermal resistance	46	°C/W
$R_{\theta JB}$	Junction-to-board thermal resistance	20.7	°C/W
Ψ_{JT}	Junction-to-top characterization parameter	5.6	°C/W
Ψ_{JB}	Junction-to-board characterization parameter	20.6	°C/W
$R_{\theta JC(bot)}$	Junction-to-case (bottom) thermal resistance	2.5	°C/W

- (1) For more information about traditional and new thermal metrics, see the *Semiconductor and IC Package Thermal Metrics* application report, [SPRA953](#).

7.5 Electrical Characteristics: $V_S = \pm 50\text{ V}$

At $T_P^{(1)} = 25^\circ\text{C}$, $R_L = 4.8\text{ k}\Omega$ to mid-supply, $V_{CM} = V_{OUT} = \text{mid-supply}$, unless otherwise noted.

PARAMETER		TEST CONDITIONS	MIN	TYP	MAX	UNIT
OFFSET VOLTAGE						
V_{OS}	Input offset voltage	$I_O = 0\text{ mA}$		± 0.2	± 4	mV
dV_{OS}/dT	Input offset voltage vs temperature	At $T_A = -40^\circ\text{C}$ to $+85^\circ\text{C}$		± 1.6	± 10	$\mu\text{V}/^\circ\text{C}$
PSRR	Input offset voltage vs power supply	$V_S = \pm 4\text{ V}$ to $\pm 60\text{ V}$, $V_{CM} = 0\text{ V}$		25	100	$\mu\text{V}/\text{V}$
INPUT BIAS CURRENT						
I_B	Input bias current	At $T_P = 25^\circ\text{C}$		± 1.4	± 100	pA
		At $T_A = -40^\circ\text{C}$ to $+85^\circ\text{C}$		See Typical Characteristics		
I_{OS}	Input offset current			± 0.2	± 100	pA
NOISE						
e_n	Input voltage noise density	$f = 10\text{ Hz}$		300		$\text{nV}/\sqrt{\text{Hz}}$
		$f = 10\text{ kHz}$		35		$\text{nV}/\sqrt{\text{Hz}}$
	Input voltage noise	$f = 0.01\text{ Hz}$ to 10 Hz		15		μV_{PP}
i_n	Current noise density	$f = 1\text{ kHz}$		40		$\text{fA}/\sqrt{\text{Hz}}$
INPUT VOLTAGE RANGE						
V_{CM}	Common-mode voltage range	Linear operation	$(V-) + 2.5$	See Note ⁽²⁾	$(V+) - 2.5$	V
		$V_S = \pm 50\text{ V}$, $-25\text{ V} \leq V_{CM} \leq 25\text{ V}$	100	146		dB
		$V_S = \pm 50\text{ V}$, $-45\text{ V} \leq V_{CM} \leq 45\text{ V}$	100	147		dB
CMRR	Common-mode rejection	At $T_A = -40^\circ\text{C}$ to $+85^\circ\text{C}$, $V_S = \pm 50\text{ V}$, $-25\text{ V} \leq V_{CM} \leq 25\text{ V}$	80	88		dB
		At $T_A = -40^\circ\text{C}$ to $+85^\circ\text{C}$, $V_S = \pm 50\text{ V}$, $-45\text{ V} \leq V_{CM} \leq 45\text{ V}$	72	82		dB
INPUT IMPEDANCE						
	Differential			$10^{13} \parallel 10$		$\Omega \parallel \text{pF}$
	Common-mode			$10^{13} \parallel 9$		$\Omega \parallel \text{pF}$
OPEN-LOOP GAIN						
A_{OL}	Open-loop voltage gain ⁽³⁾	$(V-) + 1\text{ V} < V_O < (V+) - 1\text{ V}$, $R_L = 49\text{ k}\Omega$, $I_O = \pm 1\text{ mA}$	At $T_A = -40^\circ\text{C}$ to $+85^\circ\text{C}$	100	130	dB
		$(V-) + 1\text{ V} < V_O < (V+) - 2\text{ V}$, $R_L = 4.8\text{ k}\Omega$, $I_O = \pm 10\text{ mA}$	At $T_A = -40^\circ\text{C}$ to $+85^\circ\text{C}$	100	115	dB
		$(V-) + 1\text{ V} < V_O < (V+) - 2\text{ V}$, $R_L = 4.8\text{ k}\Omega$, $I_O = \pm 10\text{ mA}$	At $T_A = -40^\circ\text{C}$ to $+85^\circ\text{C}$		106	dB
		$(V-) + 2\text{ V} < V_O < (V+) - 3\text{ V}$, $R_L = 1880\ \Omega$, $I_O = \pm 25\text{ mA}$	At $T_A = -40^\circ\text{C}$ to $+85^\circ\text{C}$	80	102	dB
					84	dB
FREQUENCY RESPONSE⁽⁴⁾						
GBW	Gain-bandwidth product	Small-signal		2.5		MHz
SR	Slew rate	$G = \pm 1$, $V_O = 80\text{-V}$ step, $R_L = 3.27\text{ k}\Omega$		13		$\text{V}/\mu\text{s}$
	Full-power bandwidth ⁽⁵⁾			35		kHz
t_s	Settling time ⁽⁶⁾	To $\pm 0.1\%$, $G = \pm 1$, $V_O = 20\text{-V}$ step		3		μs
		To $\pm 0.01\%$, $G = \pm 5$ or ± 10 , $V_O = 80\text{-V}$ step		10		μs
THD+N	Total harmonic distortion + noise ⁽⁷⁾	$V_S = +40.6\text{ V}/-39.6\text{ V}$, $G = \pm 1$, $f = 1\text{ kHz}$, $V_O = 77.2\text{ V}_{PP}$		0.0008%		

(1) T_P is the temperature of the leadframe die pad (exposed thermal pad) of the PowerPAD package.

(2) Typical range is $(V-) + 1.5\text{ V}$ to $(V+) - 1.5\text{ V}$.

(3) Measured using low-frequency ($< 10\text{ Hz}$) $\pm 49\text{-V}$ square wave. See typical characteristic curve, *Current Limit vs Temperature* (Figure 23).

(4) See [Typical Characteristics](#) curves.

(5) See typical characteristic curve, *Maximum Output Voltage vs Frequency* (Figure 11).

(6) See the [Feature Description](#) section, [Settling Time](#).

(7) Supplies reduced to allow closer swing to rails due to test equipment limitations. See typical characteristic curves *Total Harmonic Distortion + Noise vs Frequency* (Figure 29 and Figure 30) for additional power levels.

Electrical Characteristics: $V_S = \pm 50\text{ V}$ (continued)

At $T_p^{(1)} = 25^\circ\text{C}$, $R_L = 4.8\text{ k}\Omega$ to mid-supply, $V_{CM} = V_{OUT} = \text{mid-supply}$, unless otherwise noted.

PARAMETER		TEST CONDITIONS	MIN	TYP	MAX	UNIT
OUTPUT						
V_O	Voltage output swing from rail ⁽⁸⁾	$R_L = 49\text{ k}\Omega$, $A_{OL} \geq 100\text{ dB}$, $I_O = 1\text{ mA}$	(V-) + 1		(V+) – 1	V
		$R_L = 4.8\text{ k}\Omega$, $A_{OL} \geq 100\text{ dB}$, $I_O = 10\text{ mA}$	(V-) + 1		(V+) – 2	V
		$R_L = 1880\ \Omega$, $A_{OL} \geq 80\text{ dB}$, $I_O = 26\text{ mA}$	(V-) + 2		(V+) – 3	V
Continuous current output, DC		Depends on circuit conditions	See Figure 5			
I_O	Maximum peak current output, current limit ⁽³⁾			+120/–150		mA
		At $T_A = -40^\circ\text{C}$ to $+85^\circ\text{C}$		+140/–170		mA
C_{LOAD}	Capacitive load drive ⁽⁴⁾			200		pF
R_O	Open-loop output impedance		See Figure 4			Ω
Output disabled	Output capacitance			18		pF
	Feedthrough capacitance ⁽⁹⁾			150		fF
STATUS FLAG PIN (Referenced to E/D Com)						
Status Flag delay	Enable → Disable			6		μs
	Disable → Enable			4		μs
	Overcurrent delay ⁽¹⁰⁾			15		μs
	Overcurrent recovery delay ⁽¹⁰⁾			10		μs
T_J	Junction temperature	Alarm (Status Flag high)		150		$^\circ\text{C}$
		Return to normal operation (Status Flag low)		130		$^\circ\text{C}$
Output voltage ⁽⁴⁾	Normal operation				E/D Com + 2	V
	$R_L = 100\ \Omega$ during thermal overdrive, alarm		(V+) – 2.5			V
E/D (ENABLE/DISABLE) PIN						
E/D pin, referenced to E/D Com pin ⁽¹¹⁾⁽¹²⁾						
V_{SD}	High (output enabled)	Pin open or forced high	E/D Com + 2.5		E/D Com + 5	V
	Low (output disabled)	Pin forced low	E/D Com		E/D Com + 0.65	V
Output disable time				4		μs
Output enable time				3		μs
E/D COM PIN						
Voltage range			(V-)		(V+) – 5	V
POWER SUPPLY						
V_S	Specified range			± 50		V
	Operating voltage range		± 5		± 50	V
I_Q	Quiescent current	$I_O = 0\text{ mA}$		3.2	4	mA
	Quiescent current in Shutdown mode	$I_O = 0\text{ mA}$, $V_{E/D} = 0.65\text{ V}$		150	210	μA
TEMPERATURE RANGE						
T_A	Specified range		–40		85	$^\circ\text{C}$
	Operating range		–55		125	$^\circ\text{C}$

(8) See typical characteristic curve, *Output Voltage Swing vs Output Current* ([Figure 10](#)).

(9) Measured using [Figure 56](#).

(10) See *Typical Characteristics* curves for current limit behavior.

(11) See typical characteristic curve, I_{ENABLE} vs V_{ENABLE} ([Figure 45](#)).

(12) High enables the outputs.

7.6 Typical Characteristics

At $T_p = 25^\circ\text{C}$, $V_S = \pm 50\text{V}$, and $R_L = 4.8\text{ k}\Omega$ connected to GND, unless otherwise noted.

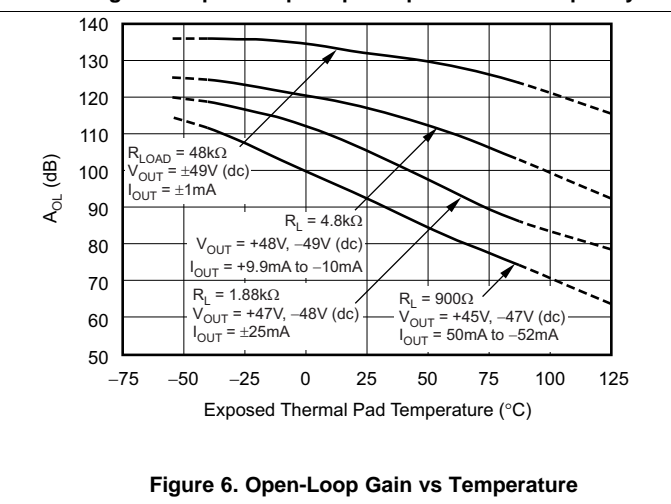
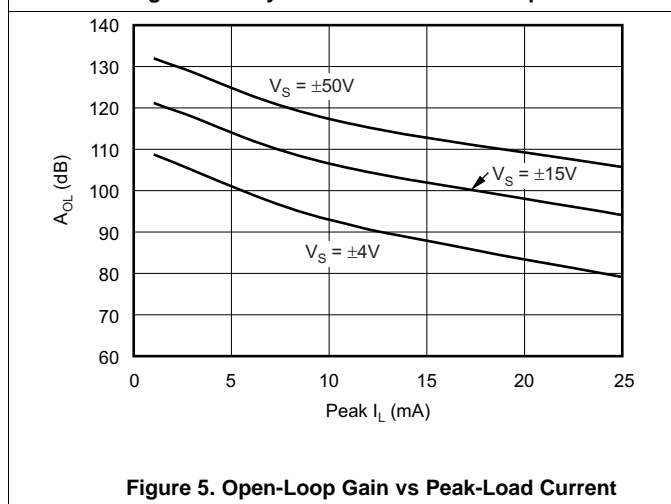
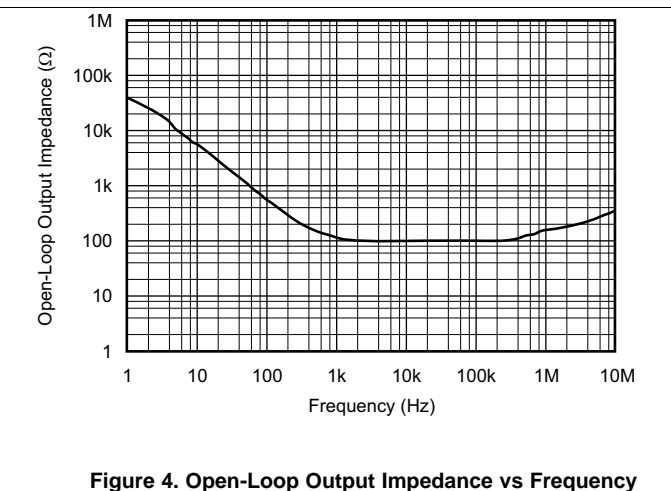
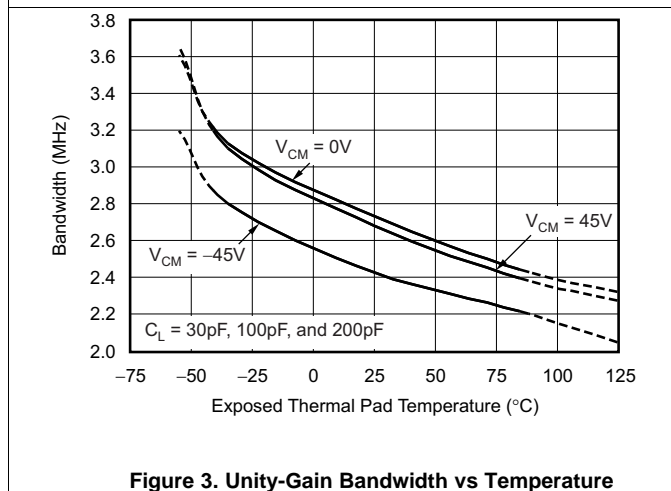
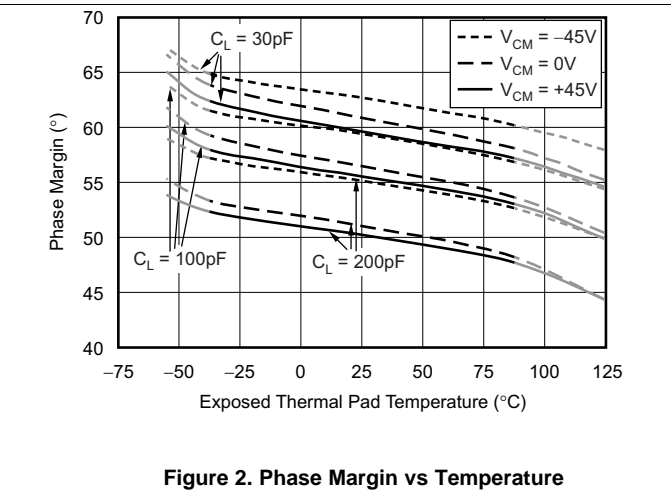
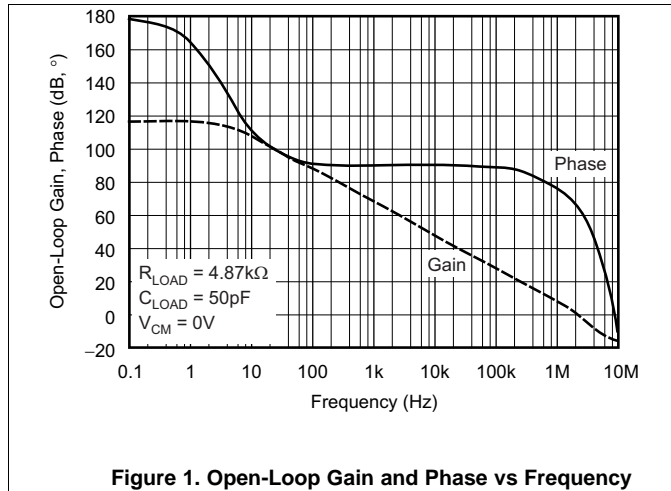

OPA454

SBOS391B – DECEMBER 2007 – REVISED MARCH 2016

www.ti.com

Typical Characteristics (continued)

At $T_p = 25^\circ\text{C}$, $V_S = \pm 50\text{ V}$, and $R_L = 4.8\text{ k}\Omega$ connected to GND, unless otherwise noted.

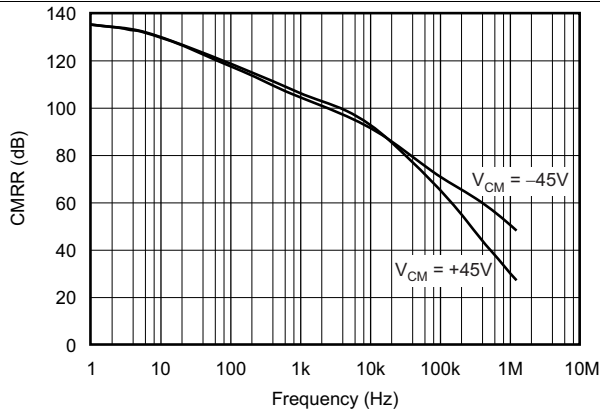

Figure 7. Common-Mode Rejection Ratio vs Frequency

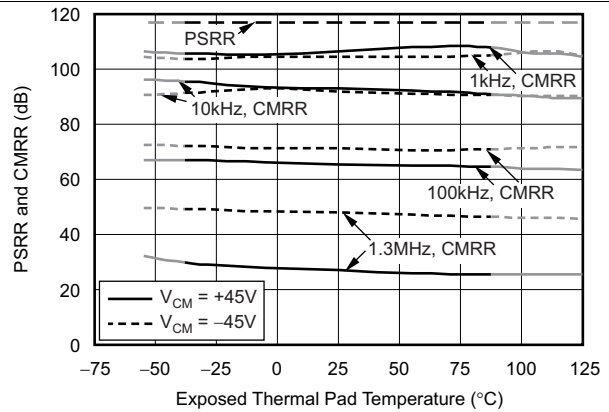

Figure 8. Power-Supply and Common-Mode Rejection Ratio vs Temperature

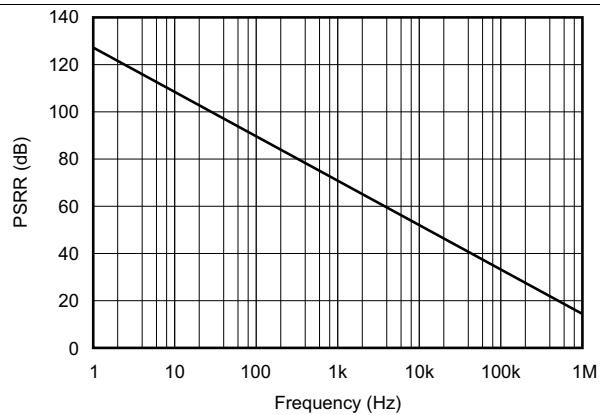

Figure 9. Power-Supply Rejection Ratio vs Frequency

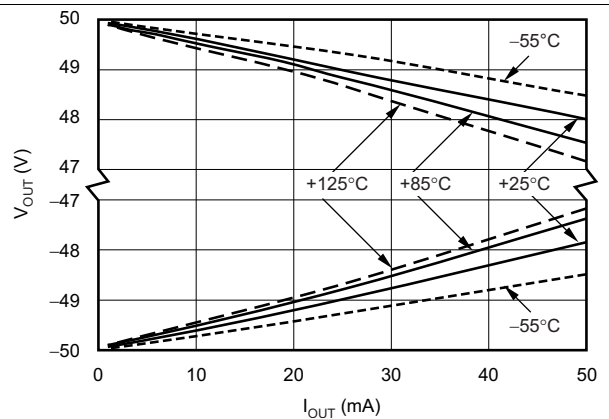

Figure 10. Output Voltage Swing vs Output Current (Measured When Status Flag Transitions From Low To High)

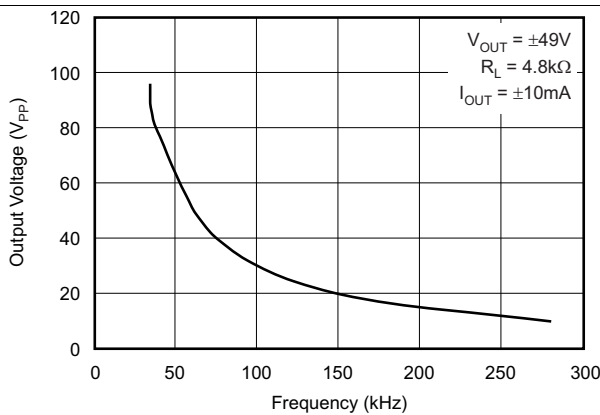

Figure 11. Maximum Output Voltage vs Frequency

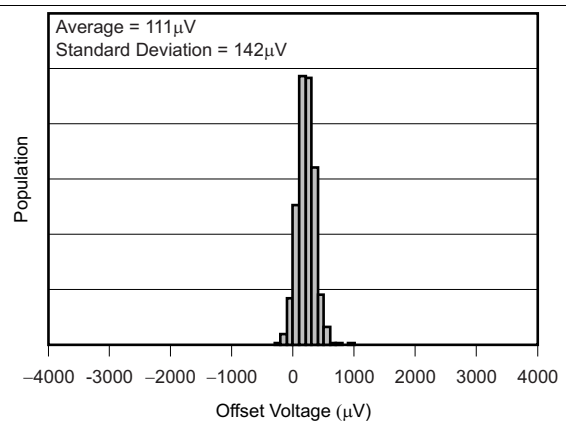

Figure 12. DDA Package Offset Voltage Production Distribution

Typical Characteristics (continued)

At $T_p = 25^\circ\text{C}$, $V_S = \pm 50\text{ V}$, and $R_L = 4.8\text{ k}\Omega$ connected to GND, unless otherwise noted.

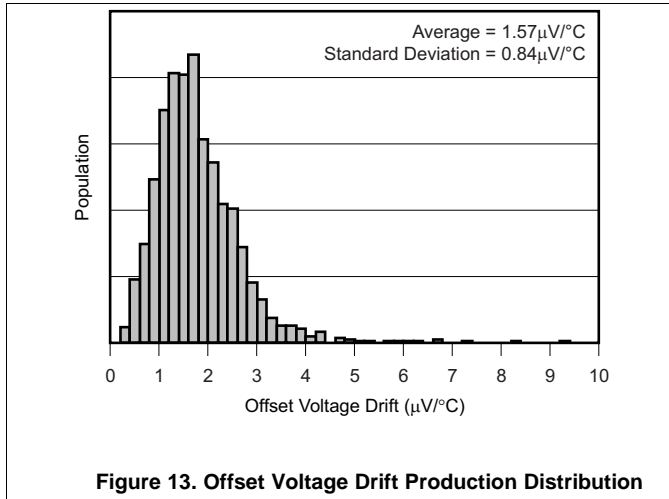

Figure 13. Offset Voltage Drift Production Distribution

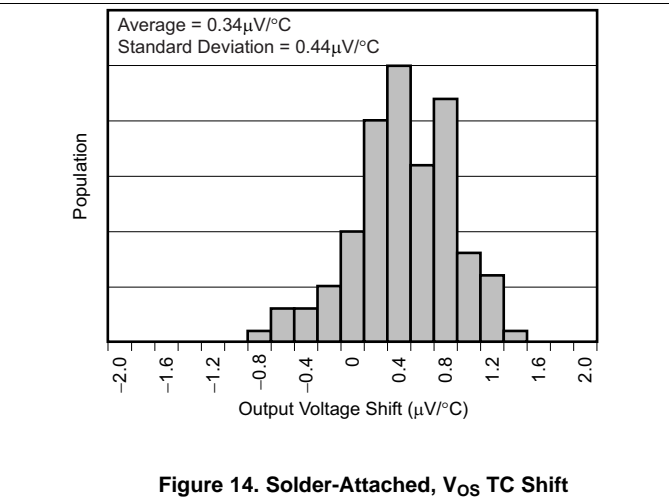

Figure 14. Solder-Attached, V_{OS} TC Shift

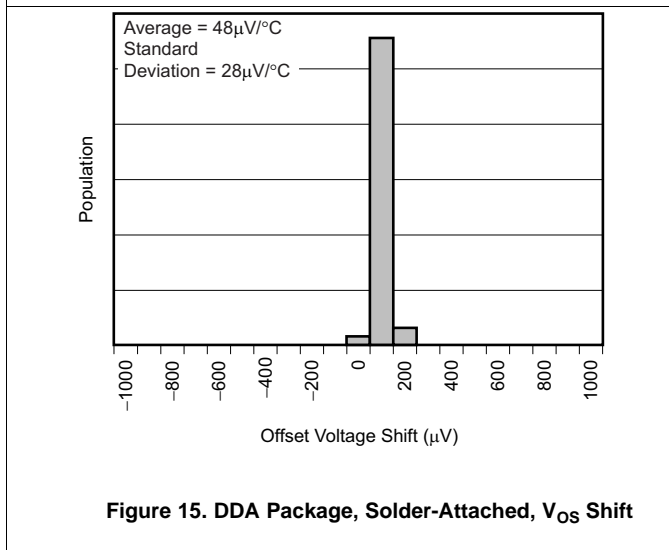

Figure 15. DDA Package, Solder-Attached, V_{OS} Shift

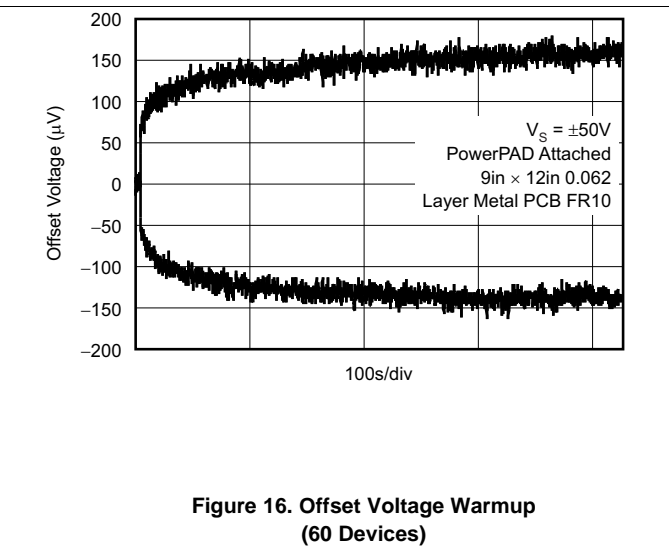

Figure 16. Offset Voltage Warmup (60 Devices)

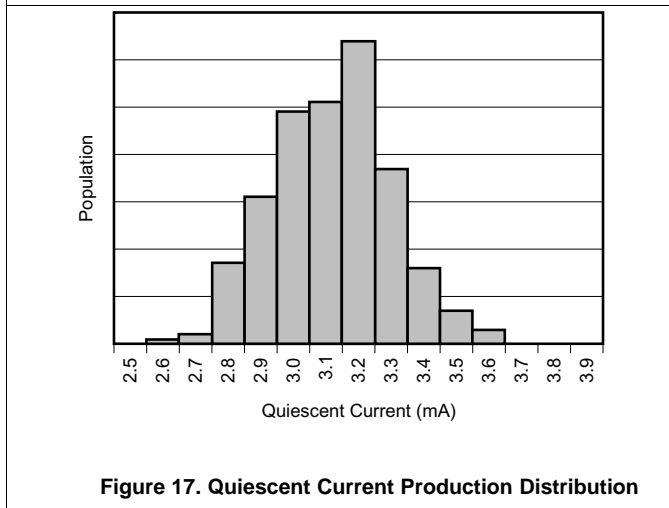

Figure 17. Quiescent Current Production Distribution

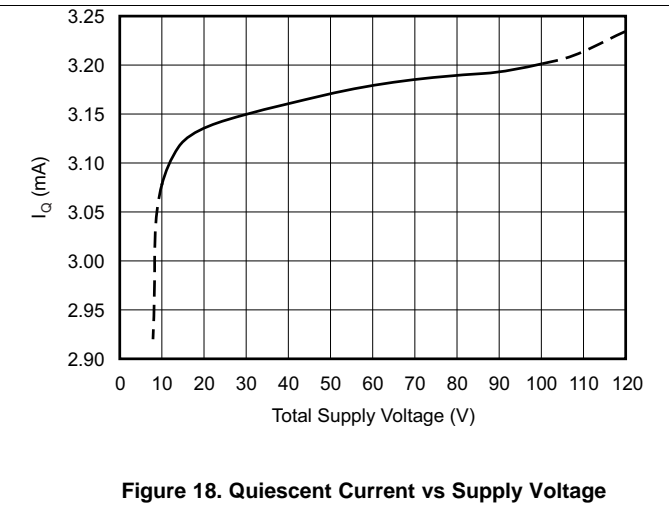

Figure 18. Quiescent Current vs Supply Voltage

Typical Characteristics (continued)

At $T_p = 25^\circ\text{C}$, $V_S = \pm 50\text{ V}$, and $R_L = 4.8\text{ k}\Omega$ connected to GND, unless otherwise noted.

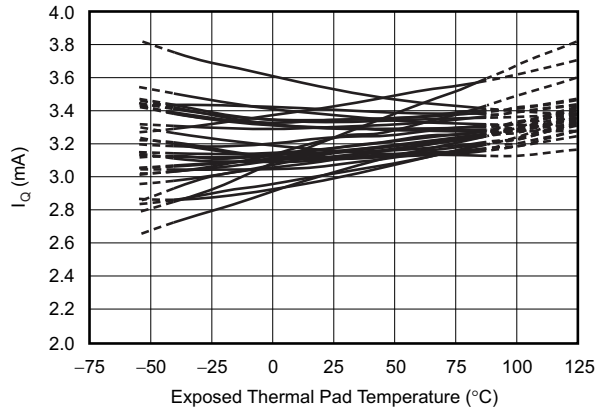

Figure 19. Quiescent Current vs Temperature

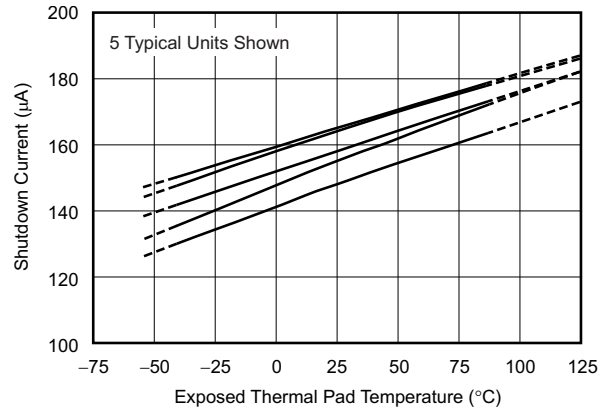

Figure 20. Shutdown Current vs Temperature

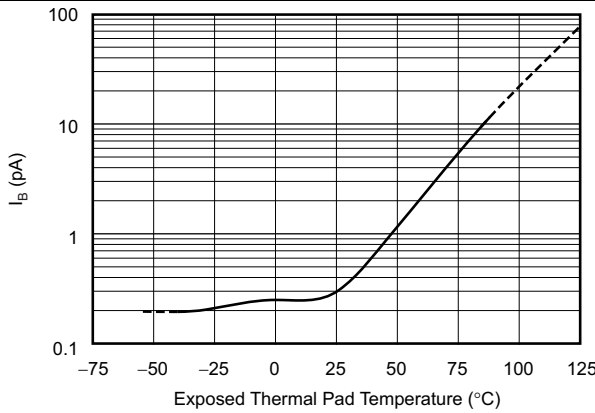

Figure 21. Input Bias Current vs Temperature

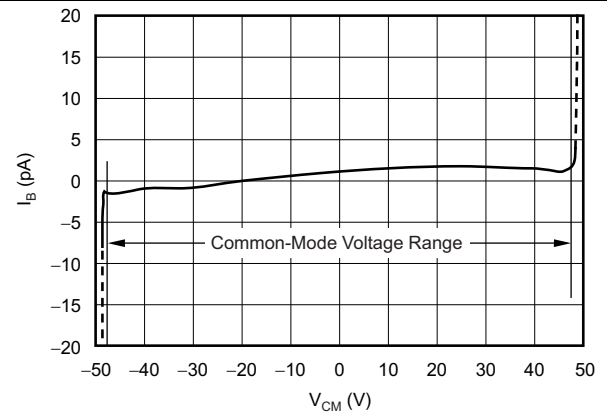

Figure 22. Input Bias Current vs Common-Mode Voltage

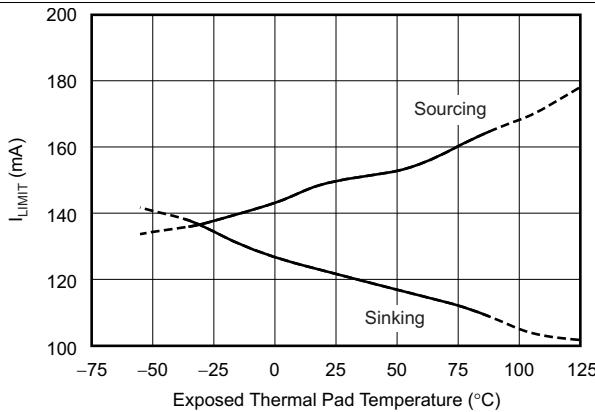
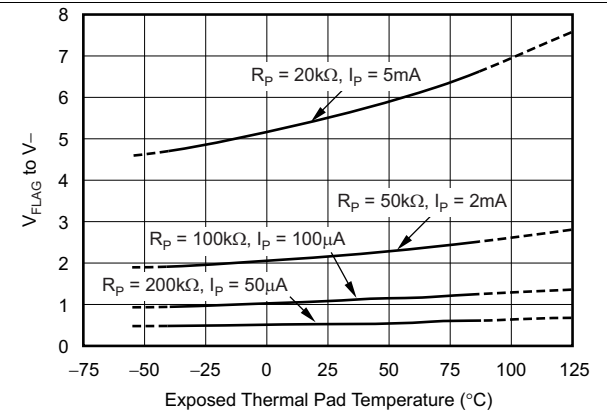

Figure 23. Current Limit vs Temperature



See Figure 72 in the [System Examples](#) section.

Figure 24. Status Flag Voltage vs Temperature (E/D Com Connected To V-)

Typical Characteristics (continued)

At $T_p = 25^\circ\text{C}$, $V_S = \pm 50\text{ V}$, and $R_L = 4.8\text{ k}\Omega$ connected to GND, unless otherwise noted.

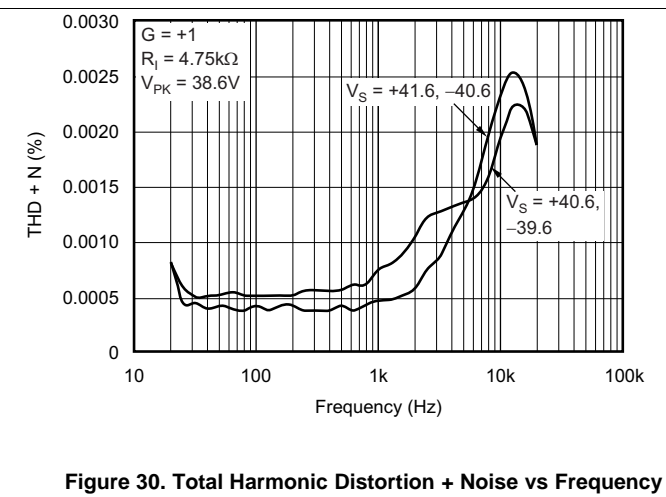
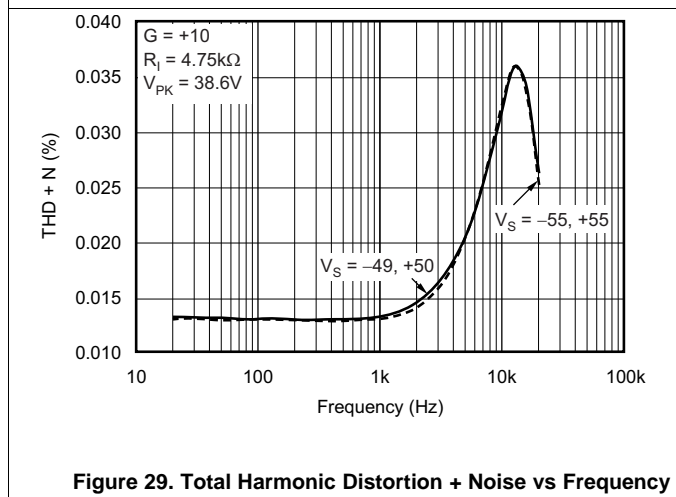
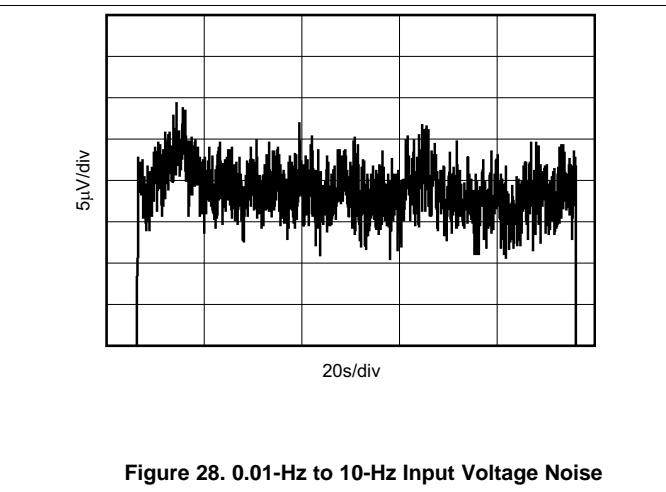
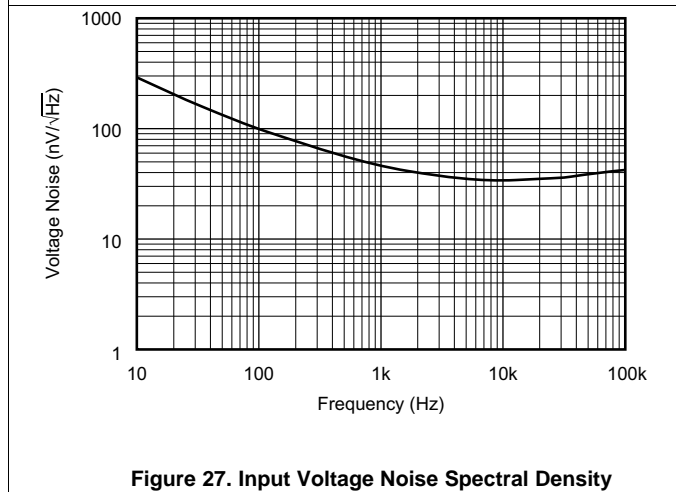
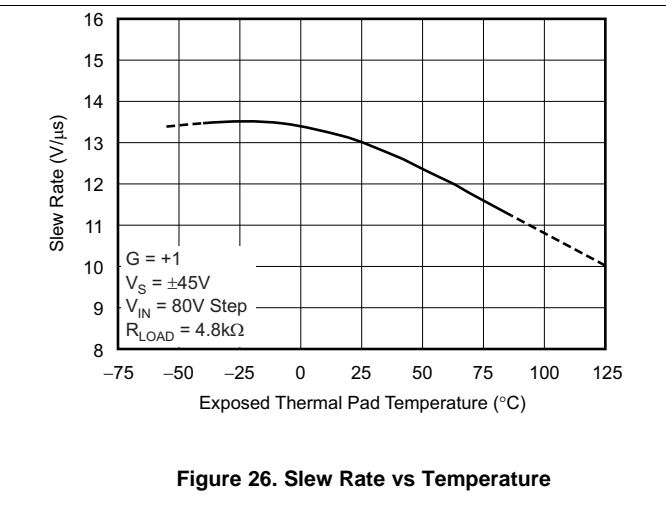
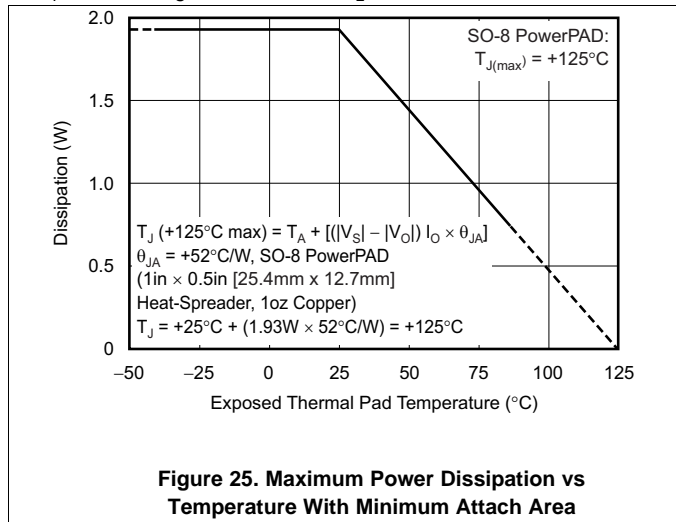

Typical Characteristics (continued)

At $T_p = 25^\circ\text{C}$, $V_S = \pm 50\text{ V}$, and $R_L = 4.8\text{ k}\Omega$ connected to GND, unless otherwise noted.

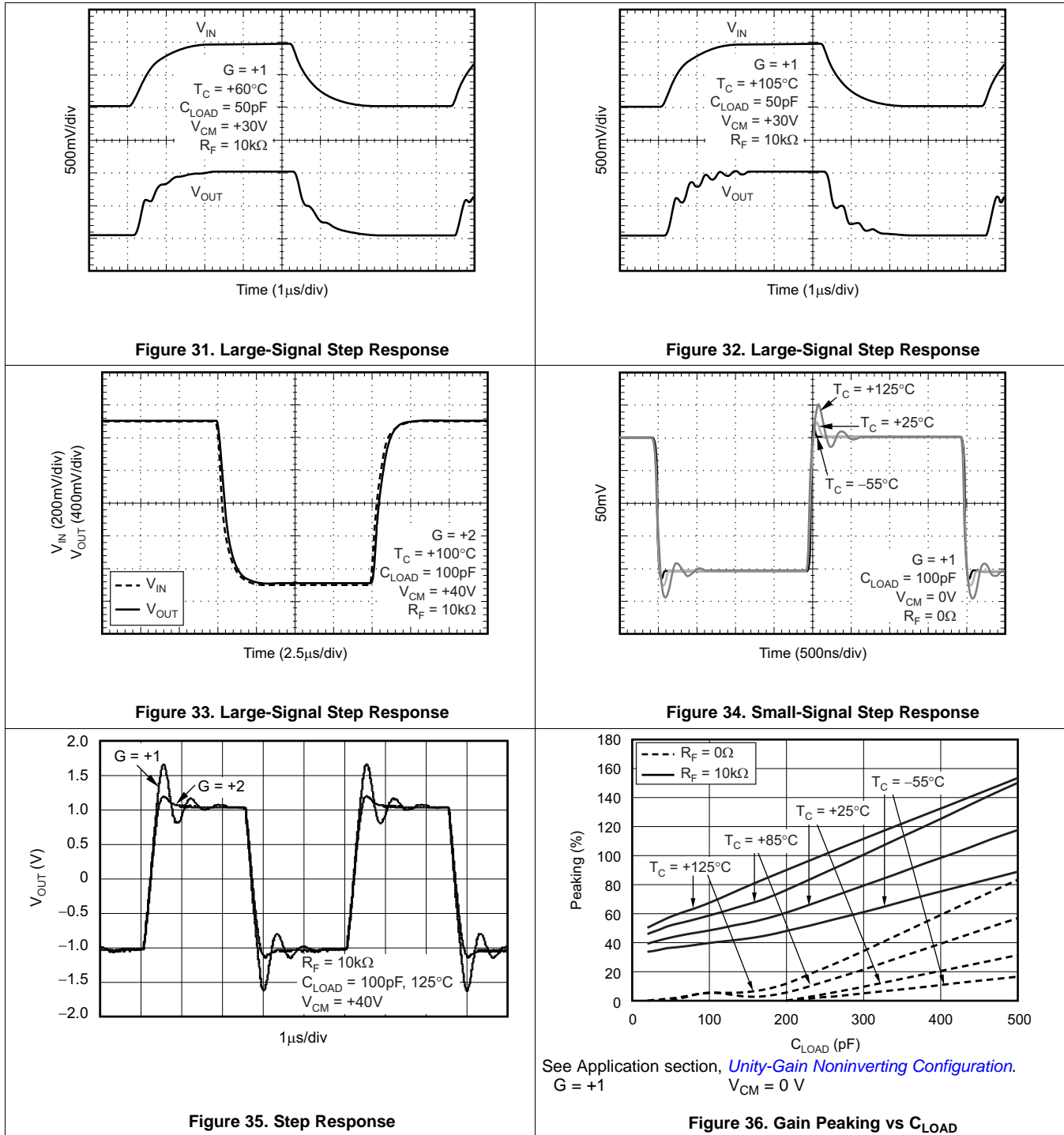

Typical Characteristics (continued)

At $T_p = 25^\circ\text{C}$, $V_S = \pm 50\text{ V}$, and $R_L = 4.8\text{ k}\Omega$ connected to GND, unless otherwise noted.

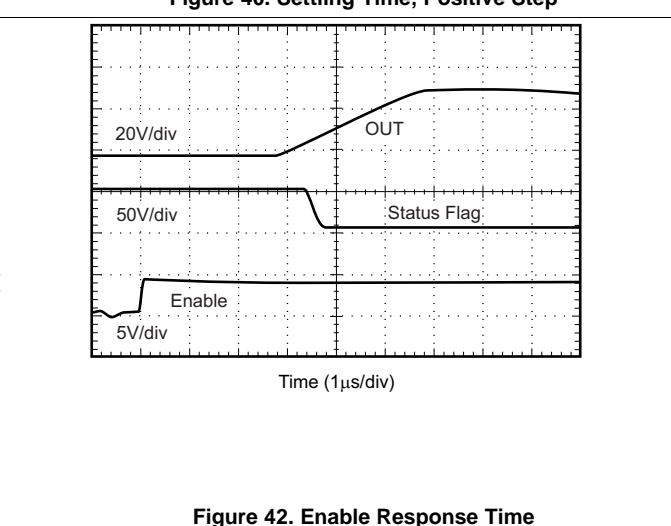
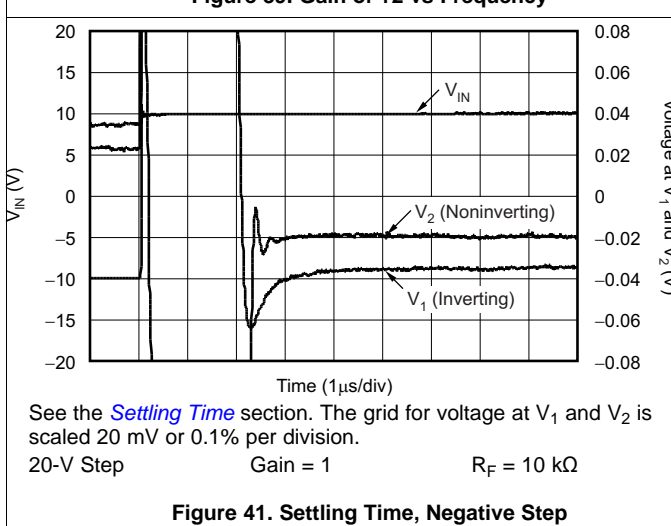
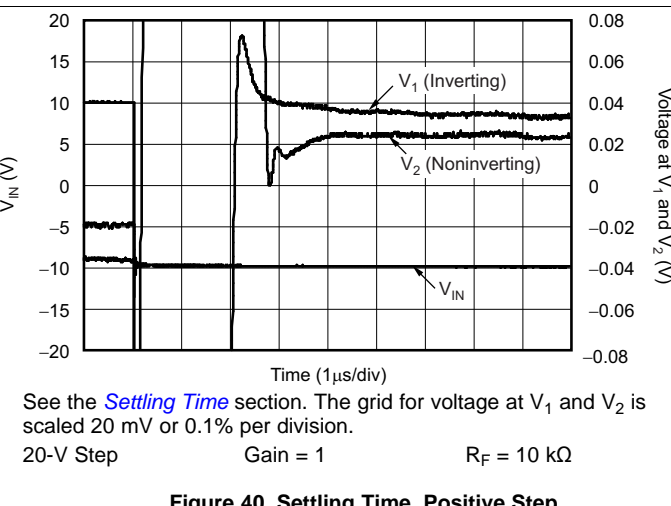
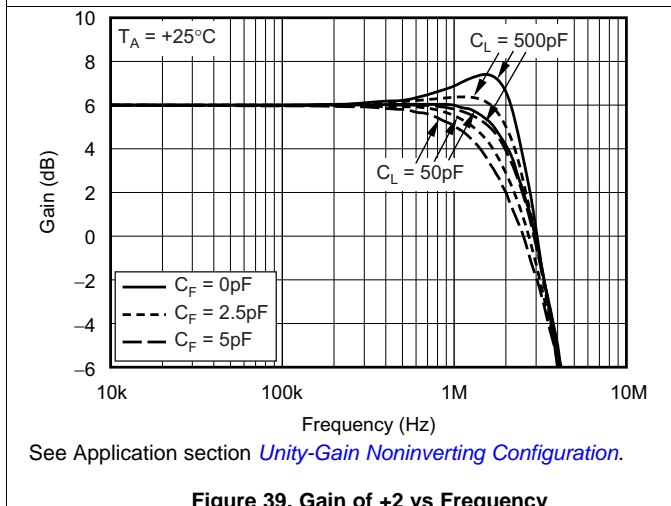
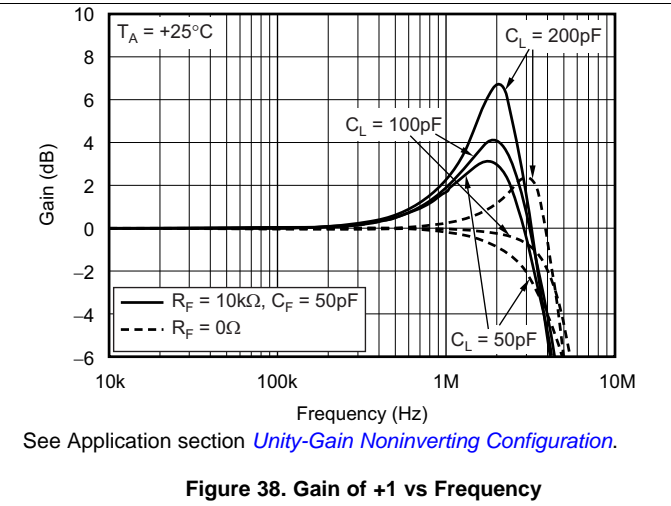
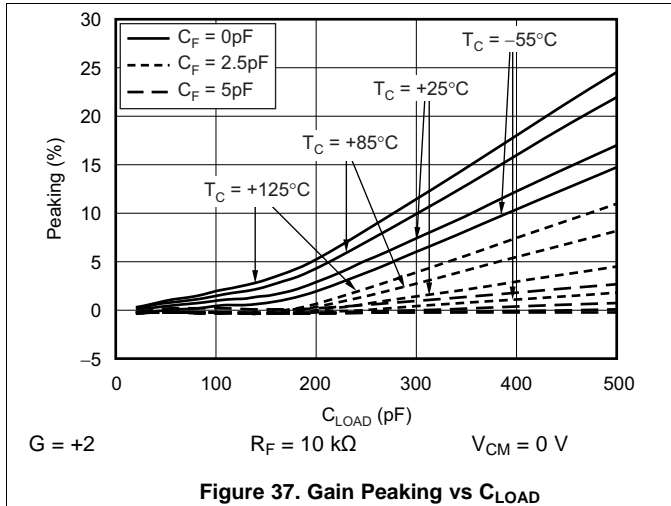

Typical Characteristics (continued)

At $T_p = 25^\circ\text{C}$, $V_S = \pm 50\text{ V}$, and $R_L = 4.8\text{ k}\Omega$ connected to GND, unless otherwise noted.

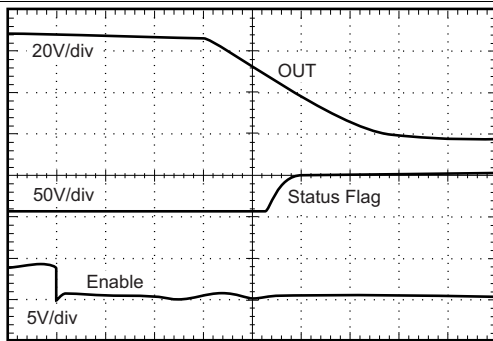

Figure 43. Disable Response Time

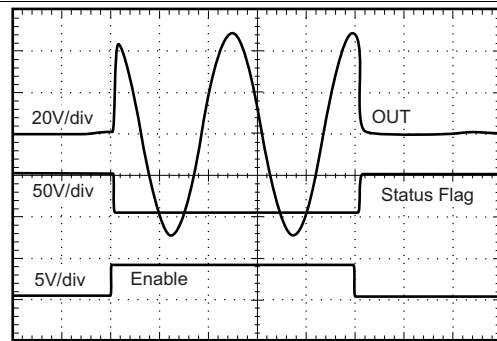

Figure 44. Enable Response

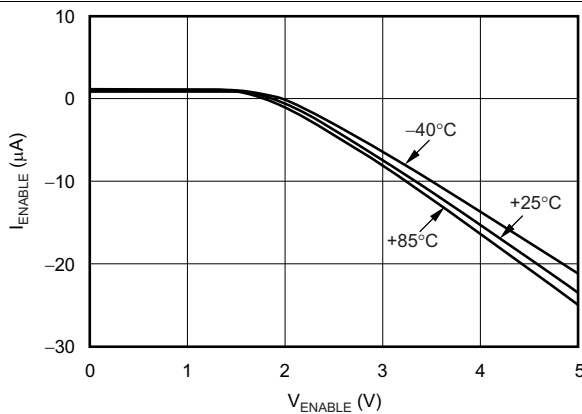

Figure 45. I_{ENABLE} vs V_{ENABLE}

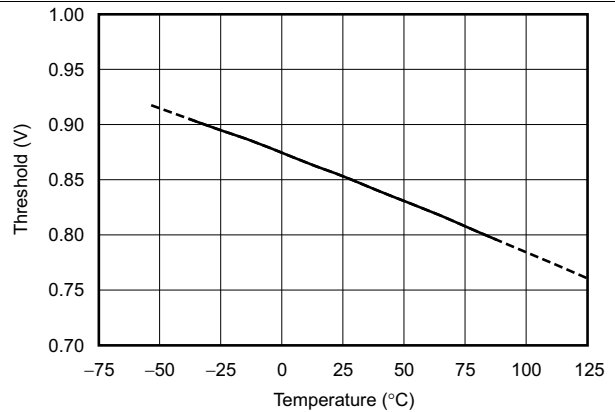
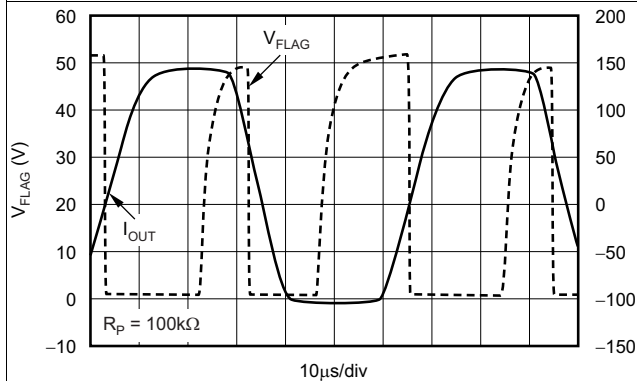
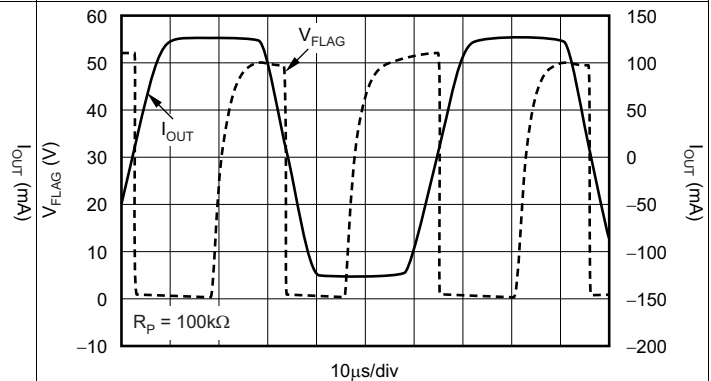

Figure 46. Enable/Disable Threshold vs Temperature



The OPA454 was connected to sufficient heatsinking to prevent thermal shutdown.
 $T_p = 125^\circ\text{C}$

Figure 47. I_{LIMIT} Showing Flag Delay ()



The OPA454 was connected to sufficient heatsinking to prevent thermal shutdown.
 $T_p = 25^\circ\text{C}$

Figure 48. I_{LIMIT} Showing Flag Delay

Typical Characteristics (continued)

At $T_p = 25^\circ\text{C}$, $V_s = \pm 50\text{ V}$, and $R_L = 4.8\text{ k}\Omega$ connected to GND, unless otherwise noted.

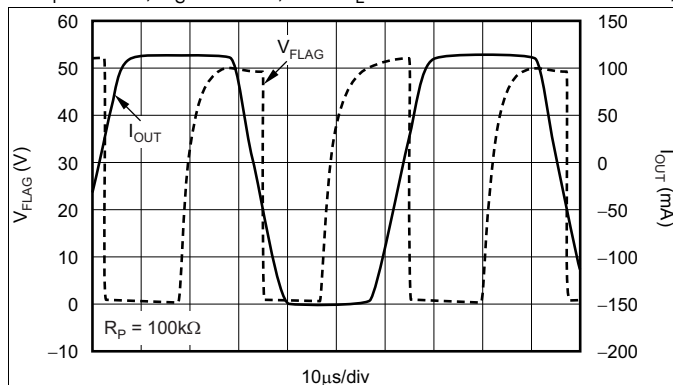

The OPA454 was connected to sufficient heatsinking to prevent thermal shutdown.

$T_p = -55^\circ\text{C}$

Figure 49. I_{LIMIT} Showing Flag Delay

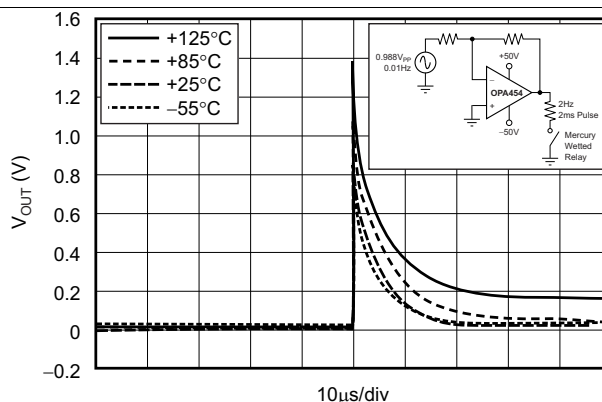

Figure 50. Apply Load (25-mA Sink Response)

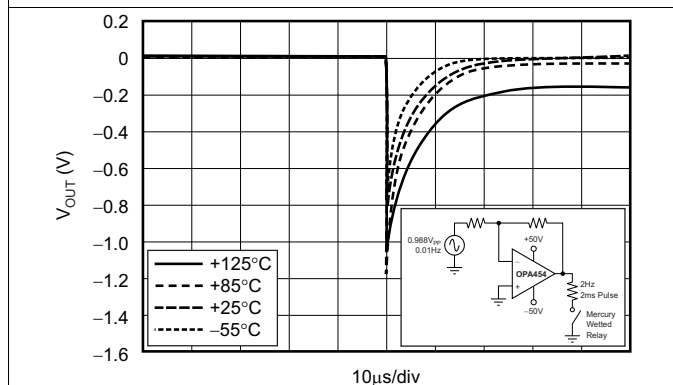

Figure 51. Remove Load (25-mA Sink Response)

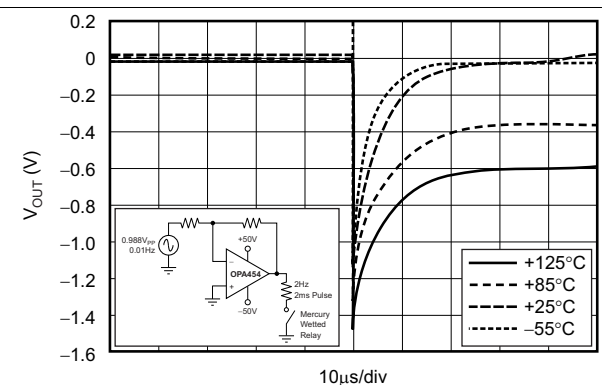

Figure 52. Apply Load (25-mA Source Response)

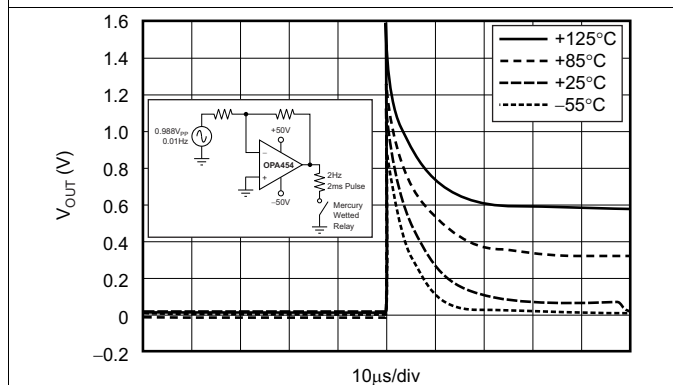

Figure 53. Remove Load (25-mA Source Response)

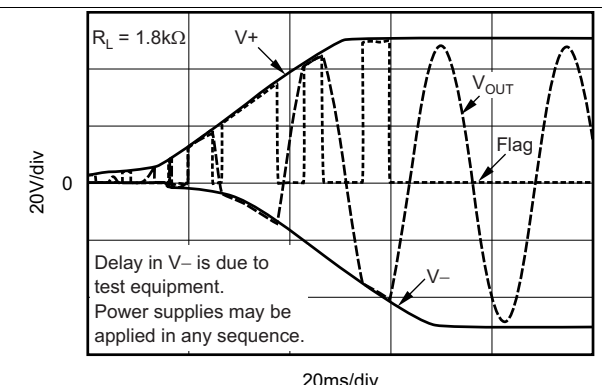

Figure 54. Power On

Typical Characteristics (continued)

At $T_p = 25^\circ\text{C}$, $V_S = \pm 50\text{ V}$, and $R_L = 4.8\text{ k}\Omega$ connected to GND, unless otherwise noted.

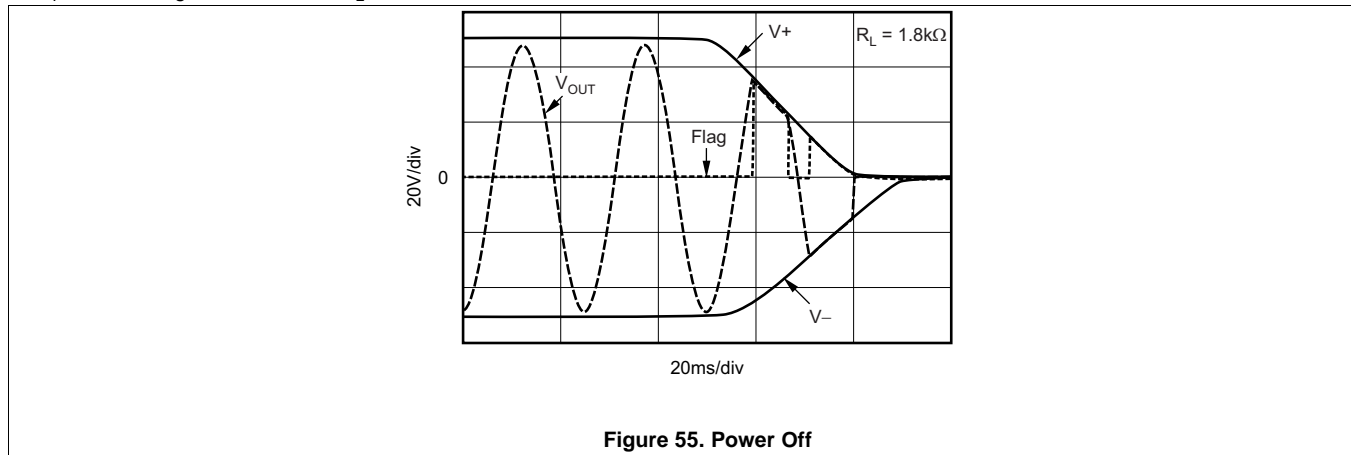

Figure 55. Power Off

8 Parameter Measurement Information

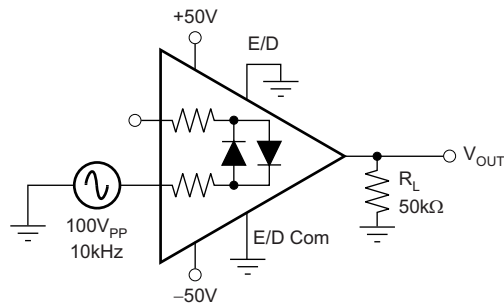

Figure 56. Feedthrough Capacitance Circuit

9 Detailed Description

9.1 Overview

The OPA454 is a low-cost operational amplifier (op amp) with high voltage (100 V) and a relatively high current drive of 50 mA. This device is unity-gain stable and features a gain-bandwidth product of 2.5 MHz. The high-voltage OPA454 offers excellent accuracy, wide output swing, and has no phase inversion problems that are typically found in similar op amps. The device can be used in virtually any $\pm 5\text{-V}$ to $\pm 50\text{-V}$ op amp configuration, and is especially useful for supply voltages greater than 36 V.

9.2 Functional Block Diagram

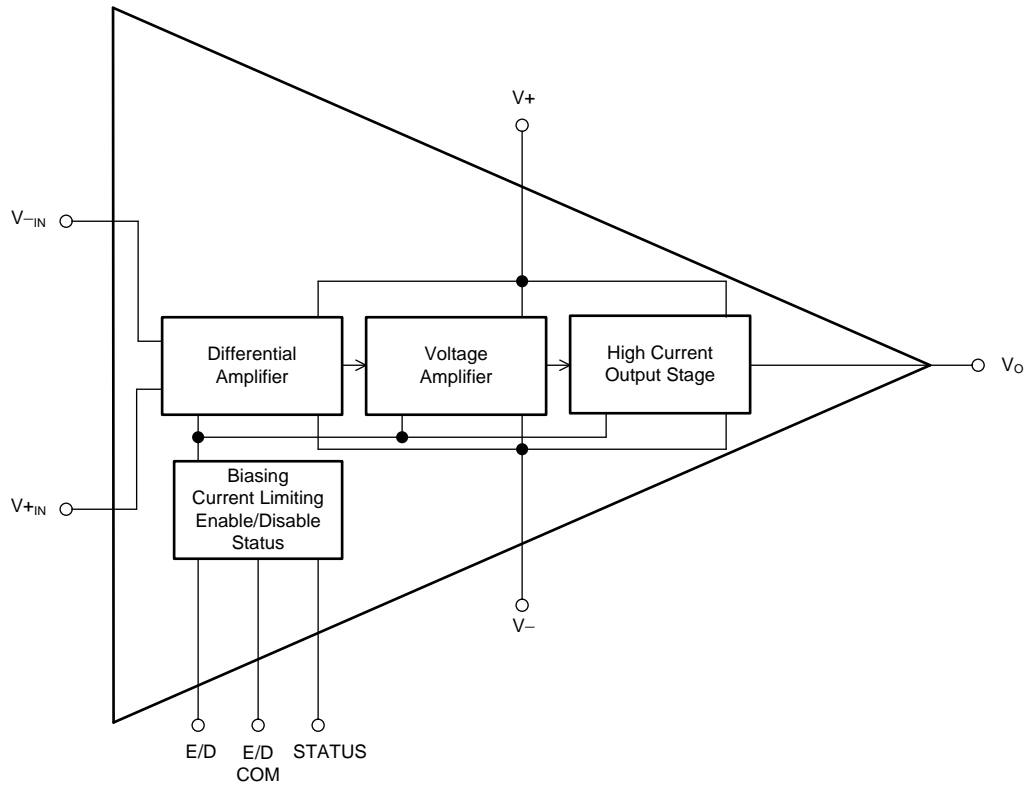

9.3 Feature Description

The OPA454 includes safety features on both the device input and output. On the input, protection is provided for a variety of fault conditions. On the output, current limiting and thermal protection are provided. Performance advantages include a ± 50 -mA output current capability along with the ability to swing to within 1 V of the supply rails. The Enable/Disable function provides the ability to turn off the output stage and reduce power consumption when not being used. The Status Flag indicates fault conditions and can be used in conjunction with the Enable/Disable function to implement fault control loops.

9.3.1 Input Protection

The OPA454 has increased protection against damage caused by excessive voltage between op amp input pins or input pin voltages that exceed the power supplies; external series resistance is not needed for protection. Internal series JFETs limit input overload current to a non-destructive 4 mA, even with an input differential voltage as large as 120 V. Additionally, the OPA454 has dielectric isolation between devices and the substrate. Therefore, the amplifier is free from the limitations of junction isolation common to many IC fabrication processes.

9.3.2 Input Range

The OPA454 is specified to give linear operation with input swing to within 2.5 V of either supply. Generally, a gain of +1 is the most demanding configuration. Figure 57 and Figure 58 show output behavior as the input swings to within 0 V of the rail, using the circuit shown in Figure 60. Figure 59 shows the behavior with an input signal that swings beyond the specified input range to within 1 V of the rail, also using the circuit in Figure 60. Notice that the beginning of the phase reversal effect may be reduced by inserting series resistance (R_S) in the connection to the positive input. V_{OUT} does not swing all the way to the opposite rail.

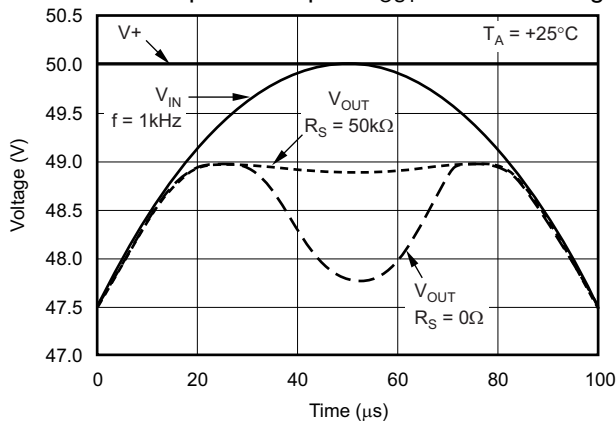

Figure 57. Output Voltage with Input Voltage up to $V+$

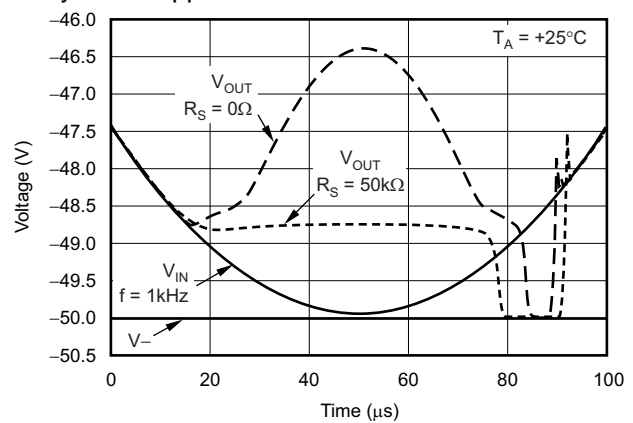

Figure 58. Output Voltage with Input Voltage Down to $V-$

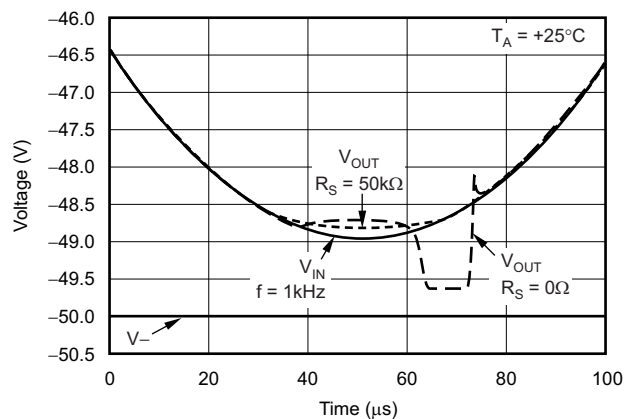

Figure 59. Output Voltage with Input Voltage Down to $(V-) + 1 V$

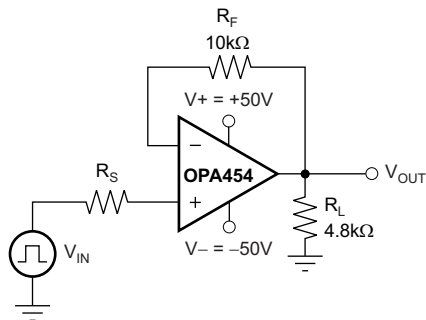

Figure 60. Input Range Test Circuit

9.3.3 Output Range

The OPA454 is specified to swing to within 1 V of either supply rail with a 49-kΩ load while maintaining excellent linearity. Swing to the rail decreases with increasing output current. The OPA454 can swing to within 2 V of the negative rail and 3 V of the positive rail with a 1.88-kΩ load. The typical characteristic curve, *Output Voltage Swing vs Output Current* (Figure 10), shows this behavior in detail.

9.3.4 Open-Loop Gain Linearity

Figure 61 shows the nonlinear relationship of A_{OL} and output voltage. As Figure 61 shows, open-loop gain is lower with positive output voltage levels compared to negative voltage levels. Specifications in *Electrical Characteristics: $V_S = \pm 50$ V* are based upon the average gain measured at both output extremes.

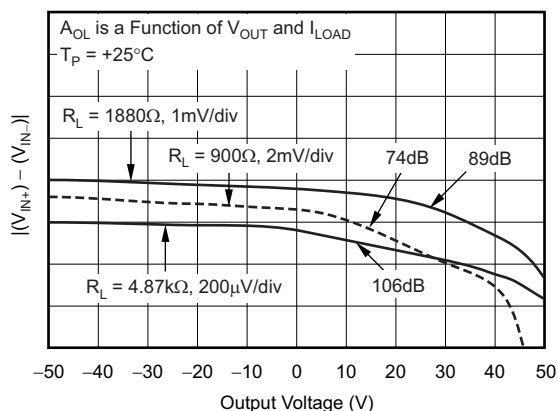

Figure 61. Differential Input Voltage (+IN to -IN) vs Output Voltage

9.3.5 Settling Time

The circuit in Figure 62 is used to measure the settling time response. The left half of the circuit is a standard, false-summing junction test circuit used for settling time and open-loop gain measurement. R_1 and R_2 provide the gain and allow for measurement without connecting a scope probe directly to the summing junction, which can disturb proper op amp function by causing oscillation.

The right half of the circuit looks at the combination of both inverting and noninverting responses. R_5 and R_6 remove the large step response. The remaining voltage at V_2 shows the small-signal settling time that is centered on zero. This test circuit can be used for incoming inspection, real-time measurement, or in designing compensation circuits in system applications.

Table 1 lists the settling time measurement circuit configuration shown in Figure 62 with different gain settings.

Table 1. Settling Time Measurement Circuit Configuration Using Different Gain Settings for Figure 62

COMPONENT	GAIN		
	1	5	10
R_1 (Ω)	10 k	2 k	1 k
R_3 (Ω)	10 k	2 k	1 k
R_7 (Ω)	10 k	4 k	9 k
R_8 (Ω)	∞	1 k	1 k
V_{IN} (V_{PP})	20	16	8

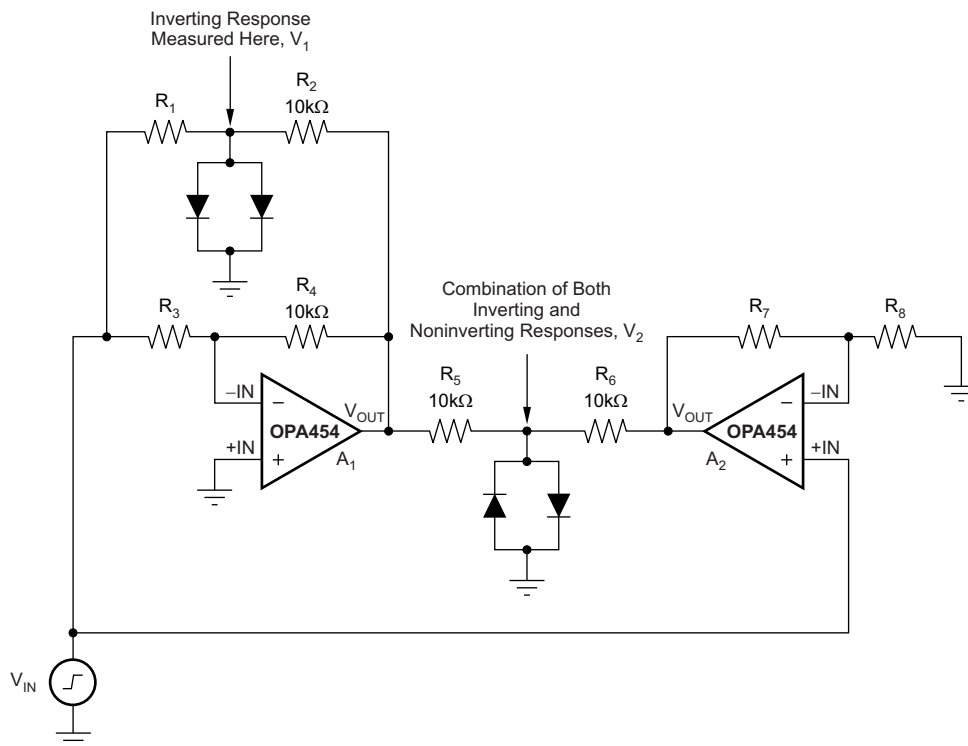

Figure 62. Settling Time Test Measurement Circuit

9.3.6 ENABLE and E/D Com

If left disconnected, E/D Com is pulled near V^- (negative supply) by an internal $10\text{-}\mu\text{A}$ current source. When left floating, ENABLE is held approximately 2 V above E/D Com by an internal $1\text{-}\mu\text{A}$ source. Even though active operation of the OPA454 results when the ENABLE and E/D Com pins are not connected, a moderately fast, negative-going signal capacitively coupled to the ENABLE pin can overpower the $1\text{-}\mu\text{A}$ pullup current and cause device shutdown. This behavior can appear as an oscillation and is encountered first near extreme cold temperatures. If the enable function is not used, a conservative approach is to connect ENABLE through a 30-pF capacitor to a low impedance source. Another alternative is the connection of an external current source from V^+ (positive supply) sufficient to hold the enable level above the shutdown threshold. Figure 63 shows a circuit that connects ENABLE and E/D Com. Choosing R_P to be $1\text{ M}\Omega$ with a $+50\text{-V}$ positive power supply voltage results in $I_P = 50\text{ }\mu\text{A}$.

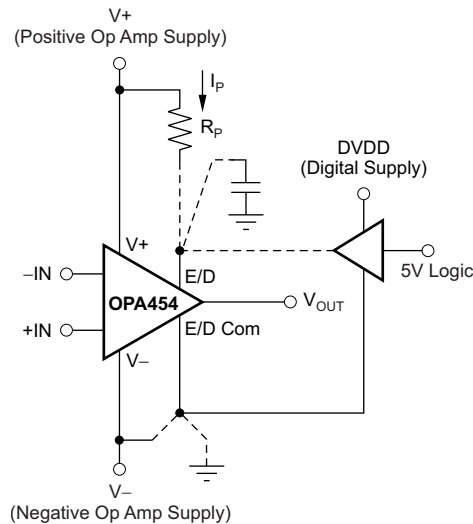

Figure 63. ENABLE and E/D Com

9.3.7 Current Limit

Figure 23 and Figure 47 to Figure 49 show the current limit behavior of the OPA454. Current limiting is accomplished by internally limiting the drive to the output transistors. The output can supply the limited current continuously, unless the die temperature rises to 150°C , which initiates thermal shutdown. With adequate heatsinking, and use of the lowest possible supply voltage, the OPA454 can remain in current limit continuously without entering thermal shutdown. Although qualification studies have shown minimal parametric shifts induced by 1000 hours of thermal shutdown cycling, this mode of operation must be avoided to maximize reliability. It is always best to provide proper heatsinking (either by a physical plate or by airflow) to remain considerably below the thermal shutdown threshold. For longest operational life of the device, keep the junction temperature below 125°C .

9.4 Device Functional Modes

A unique mode of the OPA454 is the output disable capability. This function conserves power during idle periods (quiescent current drops to approximately $150\text{ }\mu\text{A}$). This disable is accomplished without disturbing the input signal path, not only saving power but also protecting the load. This feature makes disable useful for implementing external fault shutdown loops.

10 Application and Implementation

NOTE

Information in the following applications sections is not part of the TI component specification, and TI does not warrant its accuracy or completeness. TI's customers are responsible for determining suitability of components for their purposes. Customers should validate and test their design implementation to confirm system functionality.

10.1 Applications Information

The OPA454 is a high-voltage, high-current operational amplifier capable of operating with supply voltages as high as ± 50 V, or as low as ± 10 V. Its design and processing allows it to be used in applications where most operational amplifiers cannot be used because of high-voltage power supply conditions, or as a result of the need for very high-output voltage swing. The output is capable of swinging within a volt, to a few volts, of the supply rails depending on the output current, which can be as much as ± 50 mA. In addition, the OPA454 features input overvoltage protection, built-in output current limiting, thermal protection, and an output enable/disable function.

10.1.1 Lowering Offset Voltage and Drift

The OPA454 can be used with an OPA735 zero-drift series op amp to create a high-voltage op amp circuit that has very low input offset temperature drift. This circuit is shown in Figure 64.

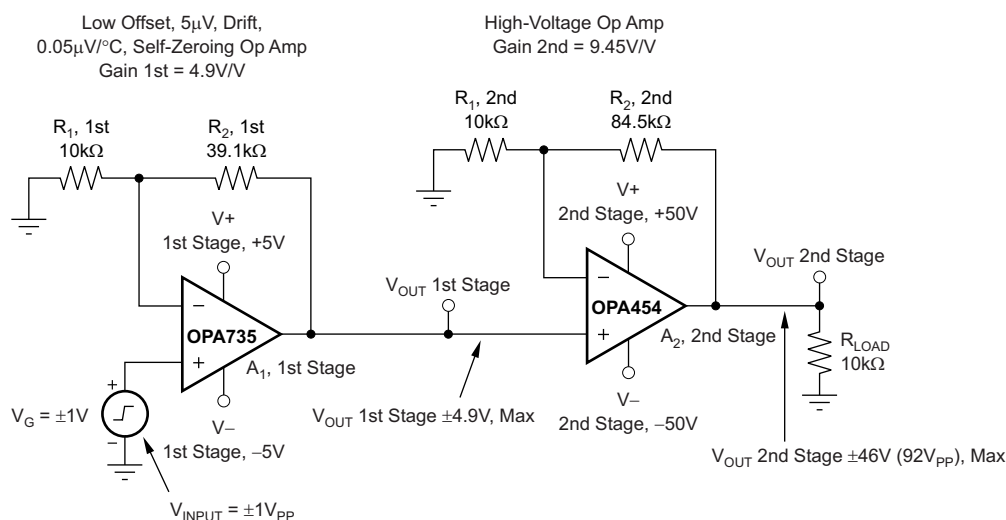

Figure 64. Two-Stage, High-Voltage Op Amp Circuit with Very Low Input Offset Temperature Drift

Applications Information (continued)

10.1.2 Increasing Output Current

The OPA454 drives an output current of a few milliamps to greater than 50 mA while maintaining good op amp performance. See Figure 6 for open-loop gain versus temperature at various output current levels.

In applications where the 25-mA output current is not sufficient to drive the required load, the output current can be increased by connecting two or more OPA454s in parallel, as Figure 65 shows. Amplifier A1 is the master amplifier and may be configured in virtually any op amp circuit. Amplifier A2, the slave, is configured as a unity-gain buffer. Alternatively, external output transistors can be used to boost output current. The circuit in Figure 66 is capable of supplying output currents up to 1 A, with the transistors shown.

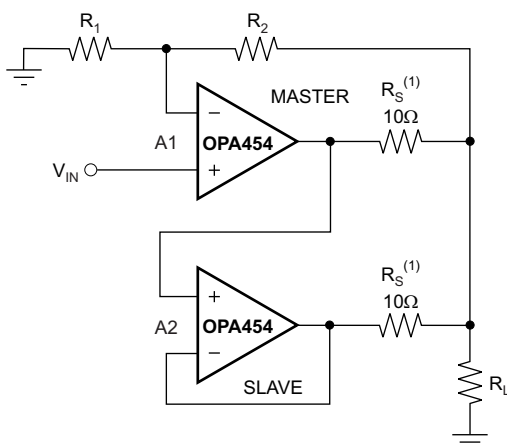

(1) R_S resistors minimize the circulating current that always flows between the two devices because of V_{OS} errors.

Figure 65. Parallel Amplifiers Increase Output Current Capability

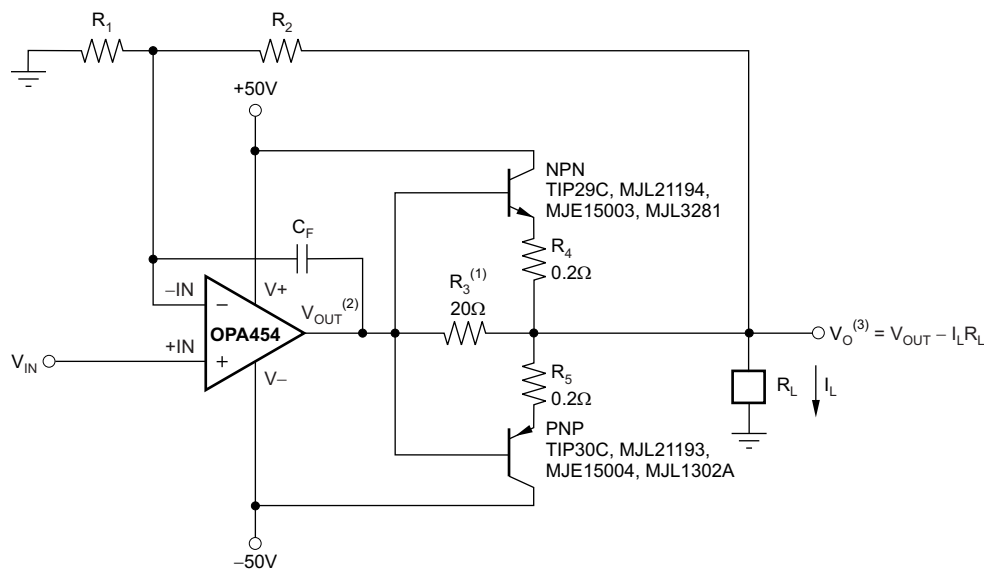

(1) Provides current limit for OPA454 and allows the amplifier to drive the load when the output is between +0.7 V and -0.7 V.

(2) Op amp V_{OUT} swings from +47 V to -48 V.

(3) V_O swings from +44.1 V to -45.1 V at $I_L = 1$ A.

Figure 66. External Output Transistors Boost Output Current Greater Than 1 A

Applications Information (continued)

10.1.3 Unity-Gain Noninverting Configuration

When in the noninverting unity-gain configuration, the OPA454 has more gain peaking with increasing positive common-mode voltage and increasing temperature. It has less gain peaking with more negative common-mode voltage. As with all op amps, gain peaking increases with increasing capacitive load. A resistor and small capacitor placed in the feedback path can reduce gain peaking and increase stability.

10.2 Typical Application

Figure 67 shows the OPA454 in a typical noninverting application with output voltage boost.

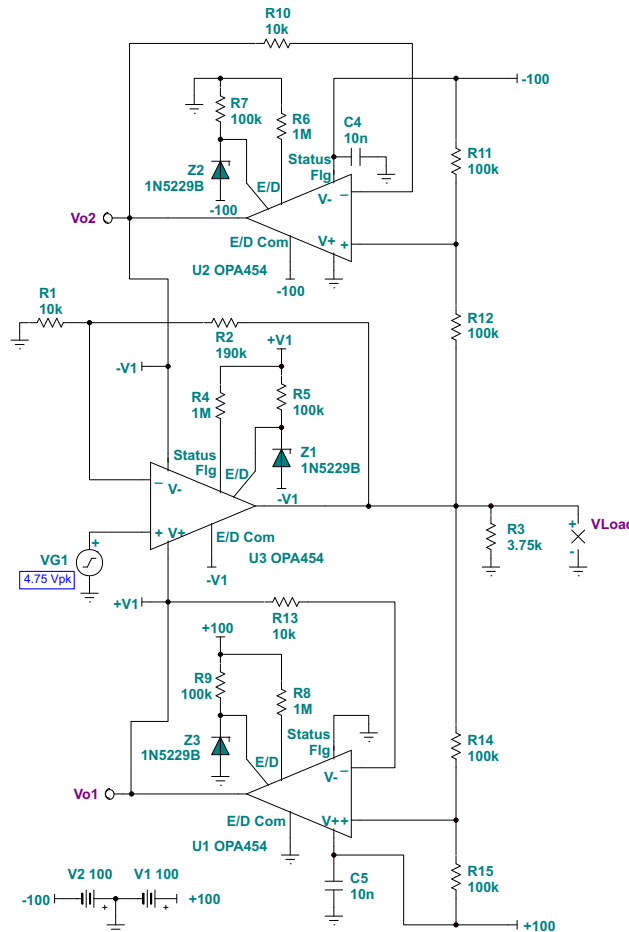

Figure 67. OPA454 Noninverting, $A_V = 20$ V/V, Output Voltage Boost

10.2.1 Design Requirements

Figure 67 shows an output voltage boost circuit where three OPA454 op amps connected as shown can produce an output voltage swing as high as $195 V_{pp}$. The resulting output swing range is twice that attainable with a single OPA454 device operating from ± 50 -V supplies, and is useful in applications where an even higher output swing is required. A ± 100 -V_{DC} power supply is required for this configuration.

Three of the design goals for this circuit are:

- A noninverting gain of 20 V/V (26 dB)
- A peak output voltage approaching 97.5 V, while delivering a peak output current of approximately 24 mA
- Correct biasing of the Enable/Disable (E/D), E/D Com, and Status flag pins

Typical Application (continued)

10.2.2 Detailed Design Procedure

U3 (an OPA454) is the only amplifier of the three devices in the application that is responsible for signal amplification. The other two op amps, U1 and U2, provide the positive and negative supply sources (respectively) for U3. The voltage gain of U3 is that of a traditional noninverting op amp amplifier. A simple relation involving U3 feedback (R_2) and input (R_1) resistors sets the closed-loop gain, A_V . Equation 1 shows this calculation.

$$A_V = \frac{V_{OUT}}{V_{IN}} = \frac{(R_1 + R_2)}{R_1} = 1 + \left[\frac{R_2}{R_1} \right]$$

where

- $R_1 = 10 \text{ k}\Omega$
 - $R_2 = 190 \text{ k}\Omega$
 - $A_V = 20 \text{ V/V}$
- (1)

Applying this gain and a V_{PK} of $\pm 97.5 \text{ V}$, the maximum input voltage that may be applied without causing the output to clip is $\pm 4.75 \text{ V}$.

U1 and U2 are connected as unity-gain buffers. The purpose of this configuration is to track the U3 output voltage, and then adjust the voltage levels at the U3 V_+ and V_- pins so that 100 V is maintained across them. This input is accomplished by the U1 and U2 input connection to the U3 output voltage through the $100\text{-k}\Omega$ voltage dividers formed by R_{11} , R_{12} , and R_{14} , R_{15} . For example, as the output of U3 moves more positive, the voltage on the U1 noninverting input moves up more closely to the $+100\text{-V}$ supply level. Even though U2 provides the U1 V_- supply, its output moves more positive as well. The result is that all the devices move together in unison up and down, while maintaining the 100-V difference between the V_+ and V_- pins for U3.

Figure 68 shows how the U3 op amp output voltage V_{LOAD} moves upward, becoming more positive, as the input voltage $VG1$ increases from -4.75 V to 4.75 V . Figure 68 also shows V_{O1} and V_{O2} , the U1 and U2 (respectively) output voltages. The 100-V difference between the supply pins is evident in the graph. Notice how the U3 V_+ pin (V_{O1}) allows 100 V greater than its V_- pin (V_{O2}).

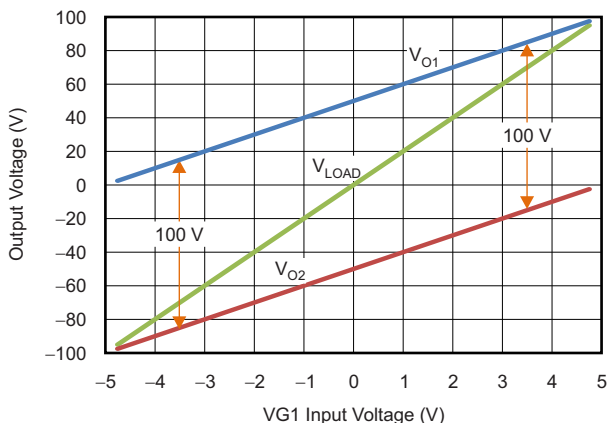

Figure 68. OPA454 Output Voltage Levels vs V_{S1} Input Voltage

Typical Application (continued)

Figure 69 shows the V_{LOAD} output, a 195- V_{PP} , 20-kHz sine wave, as developed across the 3.75-k Ω load resistor. The peak current provided by the OPA454 U3 output is 26 mA. U1 and U2 alternately source and sink the output current, in addition to the operating current required by U3.

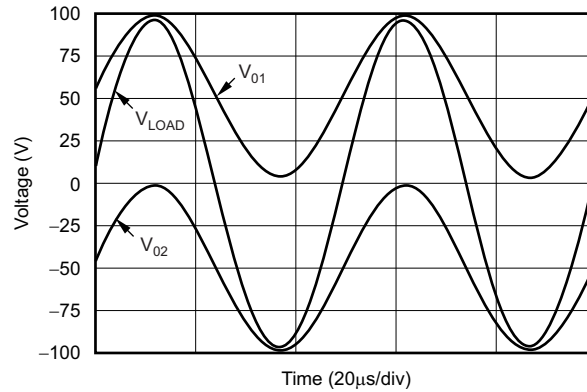

Figure 69. Output Voltage Boost Develops 195- V_{PP} V_{LOAD} Across 3.75-k Ω Load Resistance

The output voltage booster may be used in an inverting configuration also. This use is easily accomplished by applying the input signal to the input resistor R_1 as seen in Figure 70. The noninverting input is grounded and the ratio of feedback resistor R_2 to R_1 is set to 20:1 to satisfy the inverting gain equation given in Equation 2.

$$A_V = \frac{-V_{OUT}}{V_{IN}} = \frac{-R_2}{R_1}$$

where

- $R_1 = 10\text{ k}\Omega$
- $R_2 = 200\text{ k}\Omega$
- $A_V = -20\text{ V/V}$

(2)

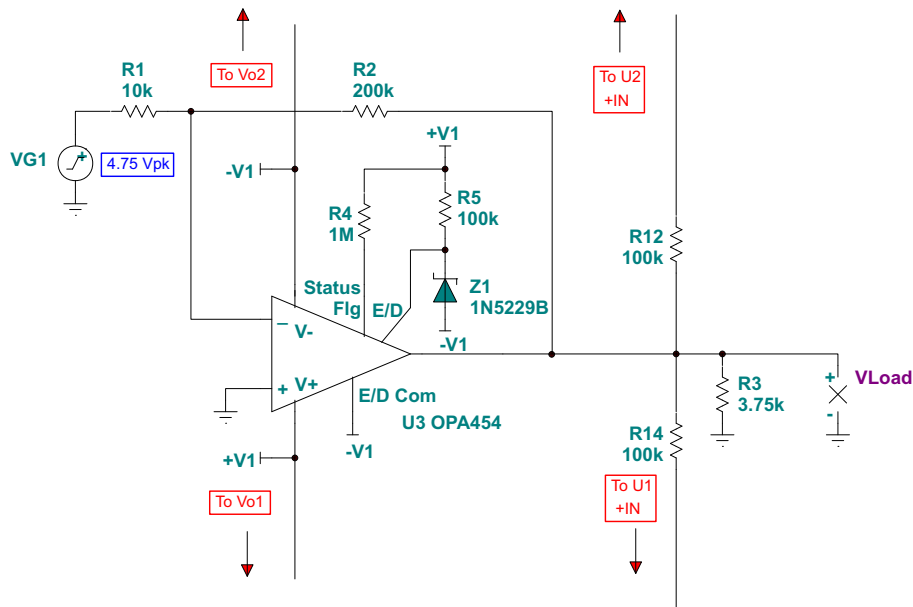

Figure 70. OPA454 Output Boost Circuit Applied as an Inverting Amplifier

Typical Application (continued)

10.2.3 Application Curve

Figure 71 shows an example of the inverting output boost amplifier output waveforms obtained from a TINA-TI simulation.

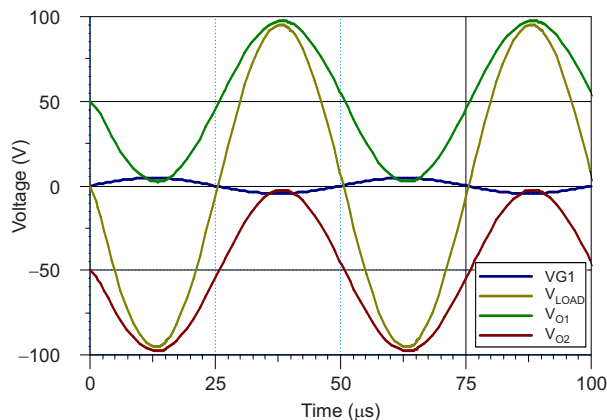

Figure 71. Voltage Levels in OPA454 Inverting Boost Amplifier Circuit from TINA-TI Simulation

10.3 System Examples

10.3.1 Basic Noninverting Amplifier

Figure 72 shows the OPA454 connected as a basic noninverting amplifier. The OPA454 can be used in virtually any $\pm 5\text{-V}$ to $\pm 50\text{-V}$ op amp configuration. It is especially useful for supply voltages greater than 36 V.

Power-supply terminals must be bypassed with 0.1- μF (or greater) capacitors, located near the power-supply pins. Be sure that the capacitors are appropriately rated for the power-supply voltage used.

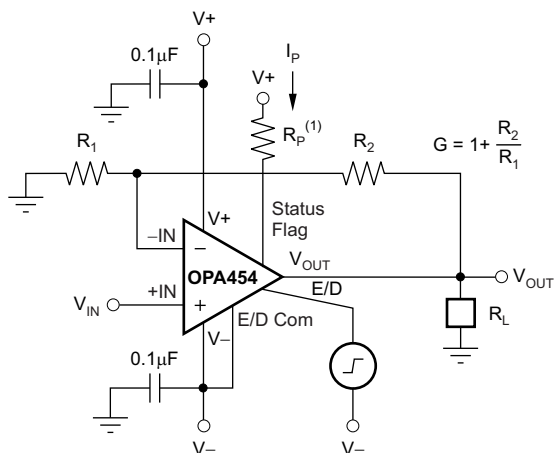

(1) Pullup resistor with at least 10 μA (choose $R_P = 1\text{ M}\Omega$ with $V_+ = 50\text{ V}$ for $I_P = 50\text{ }\mu\text{A}$).

Figure 72. Basic Noninverting Amplifier Configuration

System Examples (continued)

10.3.2 Programmable Voltage Source

Figure 73 illustrates the OPA454 in a programmable voltage source.

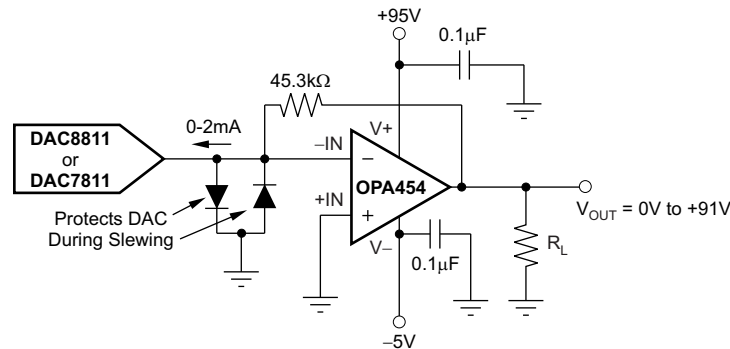
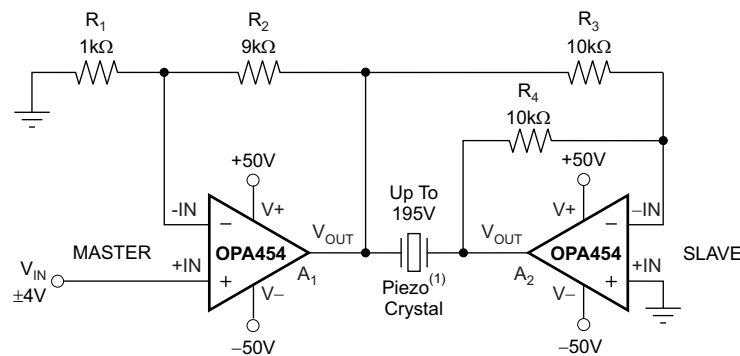

Figure 73. Programmable Voltage Source

10.3.3 Bridge Circuit

Figure 74 shows the OPA454 in a bridge circuit.



(1) For transducers with large capacitance, stabilization may become an issue. Be certain that the *Master* amplifier is stable before stabilizing the *Slave* amplifier.

Figure 74. Bridge Circuit Doubles Voltage for Exciting Piezo Crystals

10.3.4 High-Compliance Voltage Current Sources

This section describes four different applications using high-compliance voltage current sources with differential inputs. Figure 75 shows a high-voltage difference amplifier circuit. Figure 76 and Figure 78 illustrate the different applications.

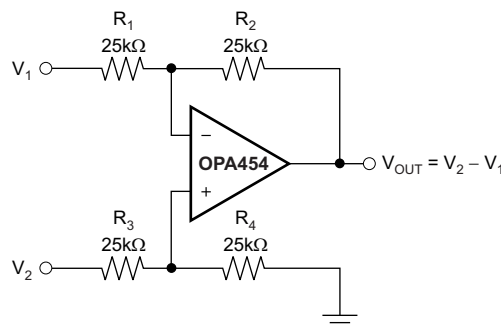

Figure 75. High-Voltage Difference Amplifier

System Examples (continued)

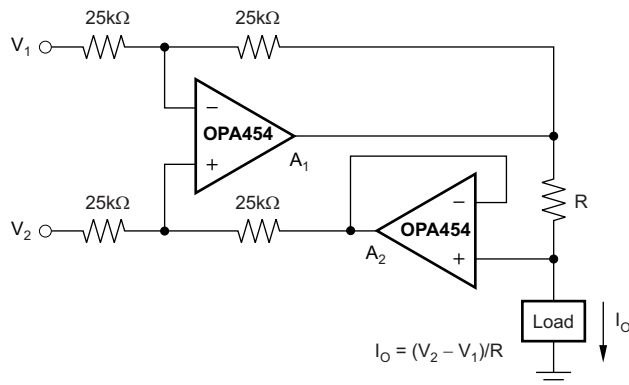

Figure 76. Differential Input Voltage-to-Current Converter for Low I_{OUT}

A red light emitting diode (LED) was used to generate Figure 77.

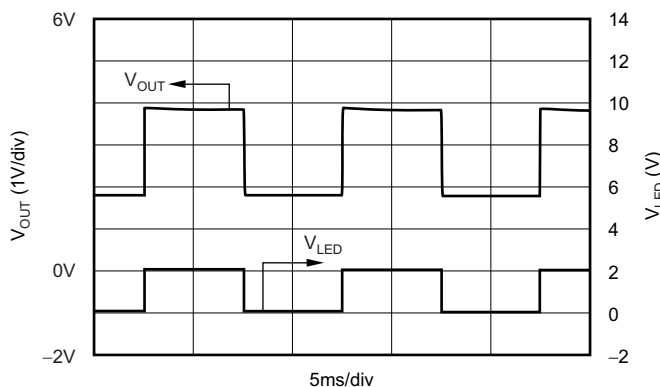

Figure 77. Avalanche Photodiode Circuit

Gain of the avalanche photodiode (APD) is adjusted by changing the voltage across the APD. Gain starts to increase when reverse voltage is increased beyond 130 V for this APD diode. See Figure 78.

System Examples (continued)

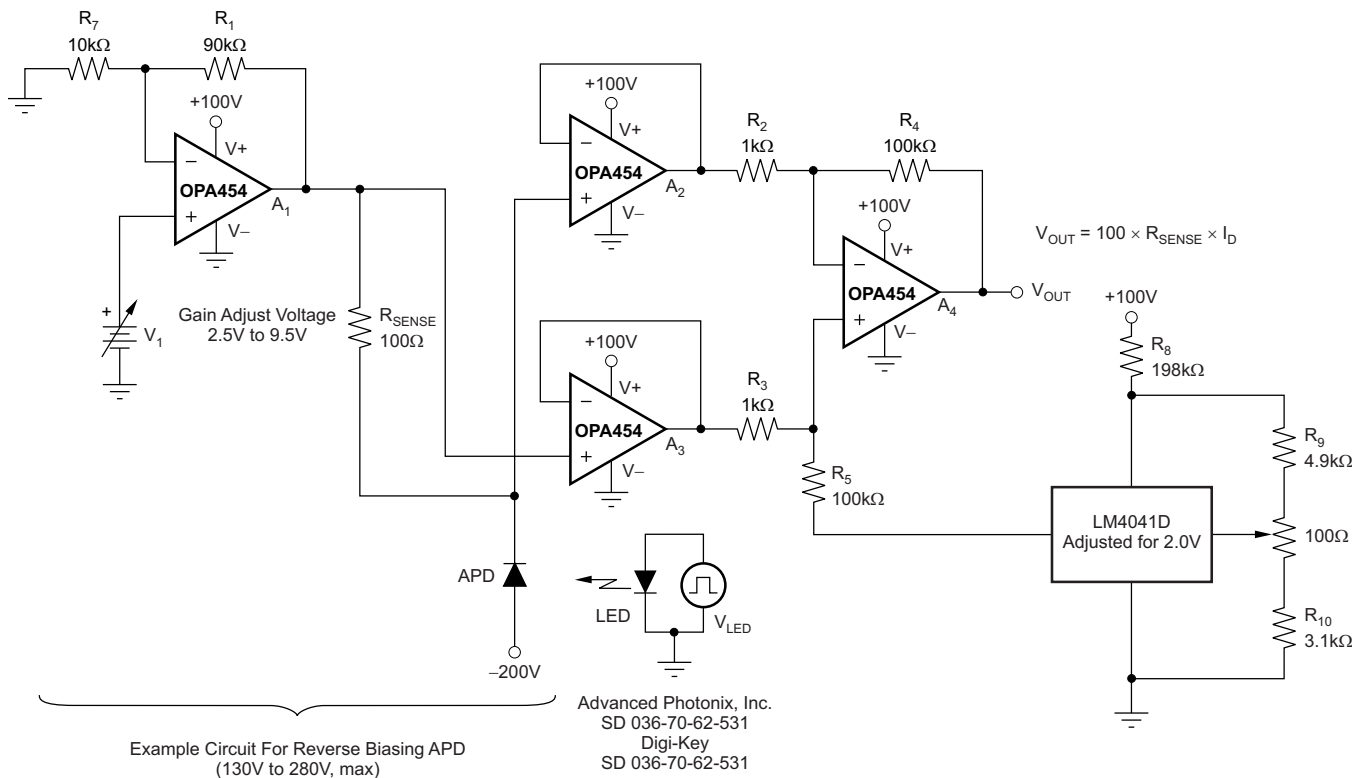
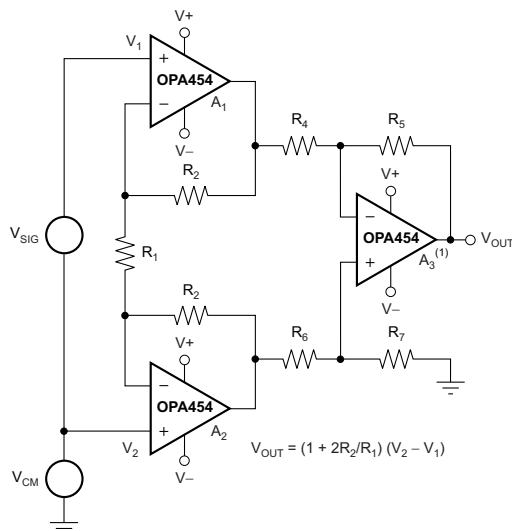

Figure 78. APD Gain Adjustment Using the OPA454, High-Voltage Op Amp

System Examples (continued)

10.3.5 High-Voltage Instrumentation Amplifier

Figure 79 uses three OPA454s to create a high-voltage instrumentation amplifier. $V_{CM} \pm V_{SIG}$ must be between $(V-) + 2.5\text{ V}$ and $(V+) - 2.5\text{ V}$. The maximum supply voltage equals $\pm 50\text{ V}$ or 100 V total.



(1) The linear input range is limited by the output swing on the input amplifiers, A_1 and A_2 .

Figure 79. High-Voltage Instrumentation Amplifier

Figure 80 uses three OPA454s to measure current in a high-side shunt application. V_{SUPPLY} must be greater than V_{CM} . V_{CM} must be between $(V-) + 2.5\text{ V}$ and $(V+) - 2.5\text{ V}$. Adhering to these restrictions keeps V_1 and V_2 within the voltage range required for linear operation of the OPA454. For example, if $V+ = 50\text{ V}$ and $V- = 50\text{ V}$, then $V_1 = +47.5\text{ V}$ (maximum) and $V_2 = -47.5\text{ V}$ (minimum). The maximum supply voltage equals $\pm 50\text{ V}$, or 100 V total.

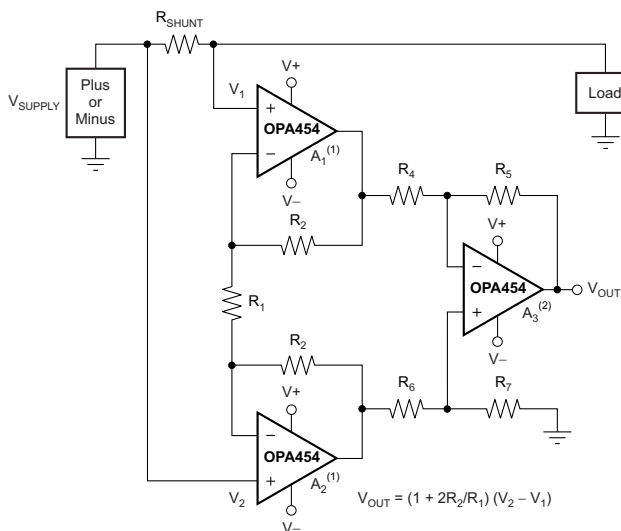

(1) To increase the linear input voltage range, configure A_1 and A_2 as unity-gain followers.

(2) The linear input range is limited by the output swing on the input amplifiers, A_1 and A_2 .

Figure 80. High-Voltage Instrumentation Amplifier for Measuring High-Side Shunt

System Examples (continued)

Figure 81 shows an example circuit that uses the OPA454 in an output voltage boost configuration with six op amp output stages.

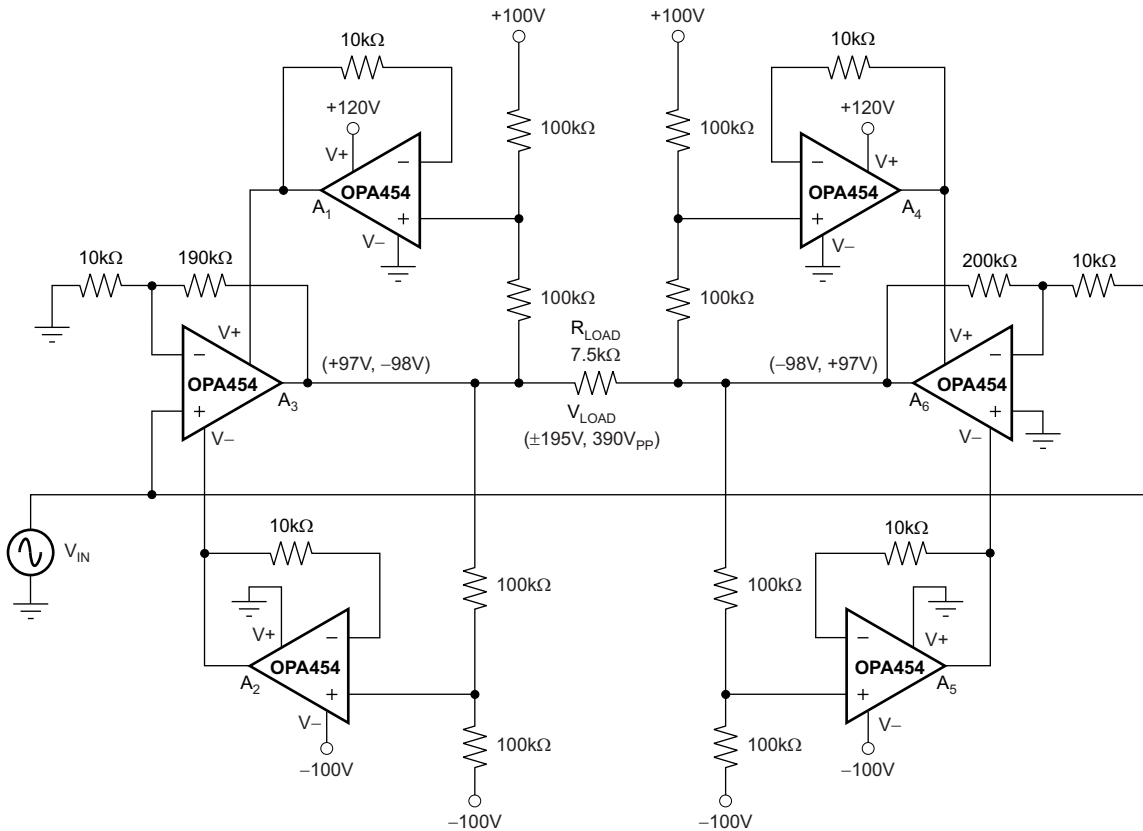
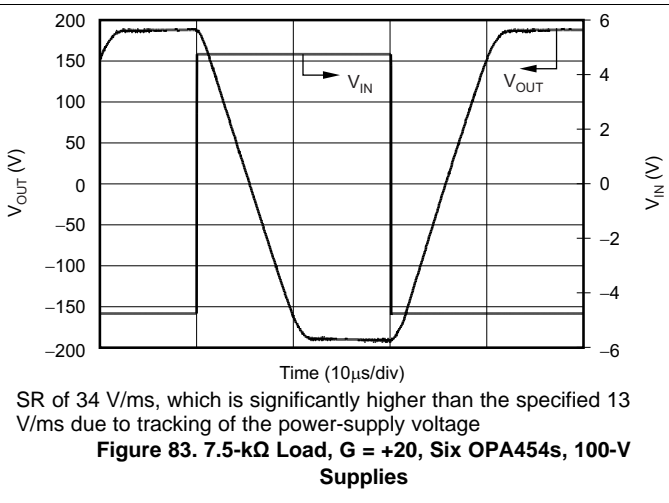
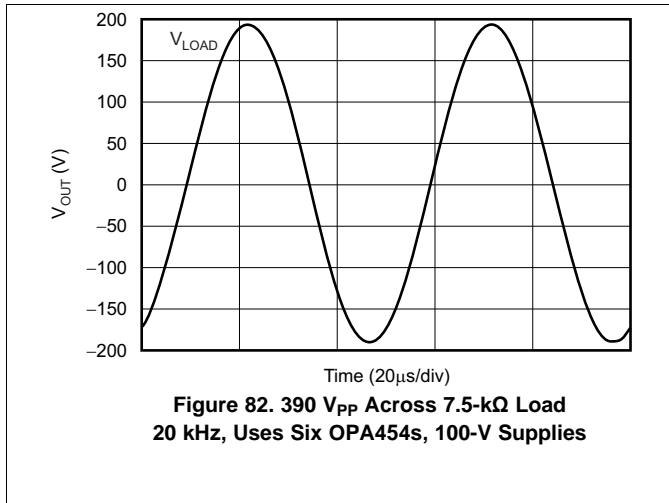

Figure 81. Output Voltage Boost with $\pm 195\text{ V}$ (390 V_{PP}) Across Bridge-Tied Load (Six Op Amps, see Figure 82 and Figure 83)



11 Power Supply Recommendations

The OPA454 may be operated from power supplies up to ± 50 V or a total of 100 V with excellent performance. Most behavior remains unchanged throughout the full operating voltage range. Parameters that vary significantly with operating voltage are shown in [Typical Characteristics](#).

Some applications do not require equal positive and negative output voltage swing. Power-supply voltages do not need to be equal. The OPA454 can operate with as little as 10 V between the supplies and with up to 100 V between the supplies. For example, the positive supply could be set to 90 V with the negative supply at -10 V, or vice-versa (as long as the total is less than or equal to 100 V).

12 Layout

12.1 Layout Guidelines

12.1.1 Thermally-Enhanced PowerPAD Package

The OPA454 comes in an 8-pin SO with PowerPAD version that provides an extremely low thermal resistance (θ_{JC}) path between the die and the exterior of the package. This package features an exposed thermal pad. This thermal pad has direct thermal contact with the die; thus, excellent thermal performance is achieved by providing a good thermal path away from the thermal pad.

The OPA454 SO-8 PowerPAD is a standard-size SO-8 package constructed using a downset leadframe upon which the die is mounted, as [Figure 84](#) shows. This arrangement results in the lead frame being exposed as a thermal pad on the underside of the package. The thermal pad on the bottom of the IC can then be soldered directly to the PCB, using the PCB as a heatsink. In addition, plated-through holes (vias) provide a low thermal resistance heat flow path to the back side of the PCB. This architecture enhances the OPA454 power dissipation capability significantly, eliminates the use of bulky heatsinks and slugs traditionally used in thermal packages, and allows the OPA454 to be easily mounted using standard PCB assembly techniques.

NOTE

Because the SO-8 PowerPAD is pin-compatible with standard SO-8 packages, the OPA454 is a drop-in replacement for operational amplifiers in existing sockets. Soldering the PowerPAD to the PCB is always required, even with applications that have low power dissipation. Soldering the device to the PCB provides the necessary thermal and mechanical connection between the leadframe die pad and the PCB.

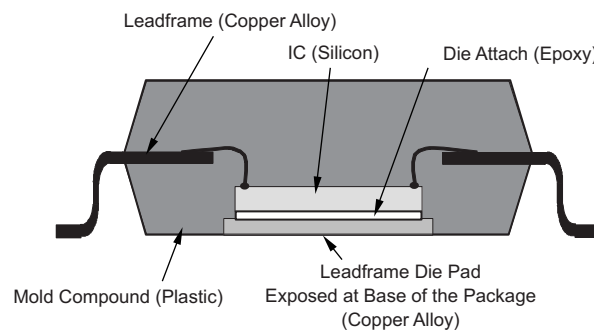

Figure 84. Cross-Section View of a PowerPAD Package

Layout Guidelines (continued)

12.1.2 PowerPAD Layout Guidelines

The PowerPAD package allows for both assembly and thermal management in one manufacturing operation. During the surface-mount solder operation (when the leads are being soldered), the thermal pad must be soldered to a copper area underneath the package. Through the use of thermal paths within this copper area, heat can be conducted away from the package into either a ground plane or other heat-dissipating device. Soldering the PowerPAD to the PCB is always required, even with applications that have low power dissipation. Follow these steps to attach the device to the PCB:

1. The PowerPAD must be connected to the most negative supply voltage on the device, V_{-} .
2. Prepare the PCB with a top-side etch pattern. There must be etching for the leads as well as etch for the thermal pad.
3. Use of thermal vias improves heat dissipation, but are not required. The thermal pad can connect to the PCB using an area equal to the pad size with no vias, but externally connected to V_{-} .
4. Place recommended holes in the area of the thermal pad. Recommended thermal land size and thermal via patterns for the SO-8 DDA package are shown in the thermal land pattern mechanical drawing appended at the end of this document. These holes must be 13 mils (.013 in, or 0.3302 mm) in diameter. Keep them small, so that solder wicking through the holes is not a problem during reflow. The minimum recommended number of holes for the SO-8 PowerPAD package is five.
5. Additional vias may be placed anywhere along the thermal plane outside of the thermal pad area. These vias help dissipate the heat generated by the OPA454 IC. These additional vias may be larger than the 13-mil diameter vias directly under the thermal pad. They can be larger because they are not in the thermal pad area to be soldered; thus, wicking is not a problem.
6. Connect all holes to the internal power plane of the correct voltage potential (V_{-}).
7. When connecting these holes to the plane, do not use the typical web or spoke via connection methodology. Web connections have a high thermal resistance connection that is useful for slowing the heat transfer during soldering operations, making the soldering of vias that have plane connections easier. In this application, however, low thermal resistance is desired for the most efficient heat transfer. Therefore, the holes under the OPA454 PowerPAD package must make the connections to the internal plane with a complete connection around the entire circumference of the plated-through hole.
8. The top-side solder mask must leave the terminals of the package and the thermal pad area exposed. The bottom-side solder mask must cover the holes of the thermal pad area. This masking prevents solder from being pulled away from the thermal pad area during the reflow process.
9. Apply solder paste to the exposed thermal pad area and all of the IC terminals.
10. With these preparatory steps in place, the PowerPAD IC is simply placed in position and run through the solder reflow operation as any standard surface-mount component. This preparation results in a properly installed part.

For detailed information on the PowerPAD package, including thermal modeling considerations and repair procedures, see technical brief [SLMA002 PowerPAD Thermally-Enhanced Package](#), available for download at www.ti.com.

12.2 Layout Example

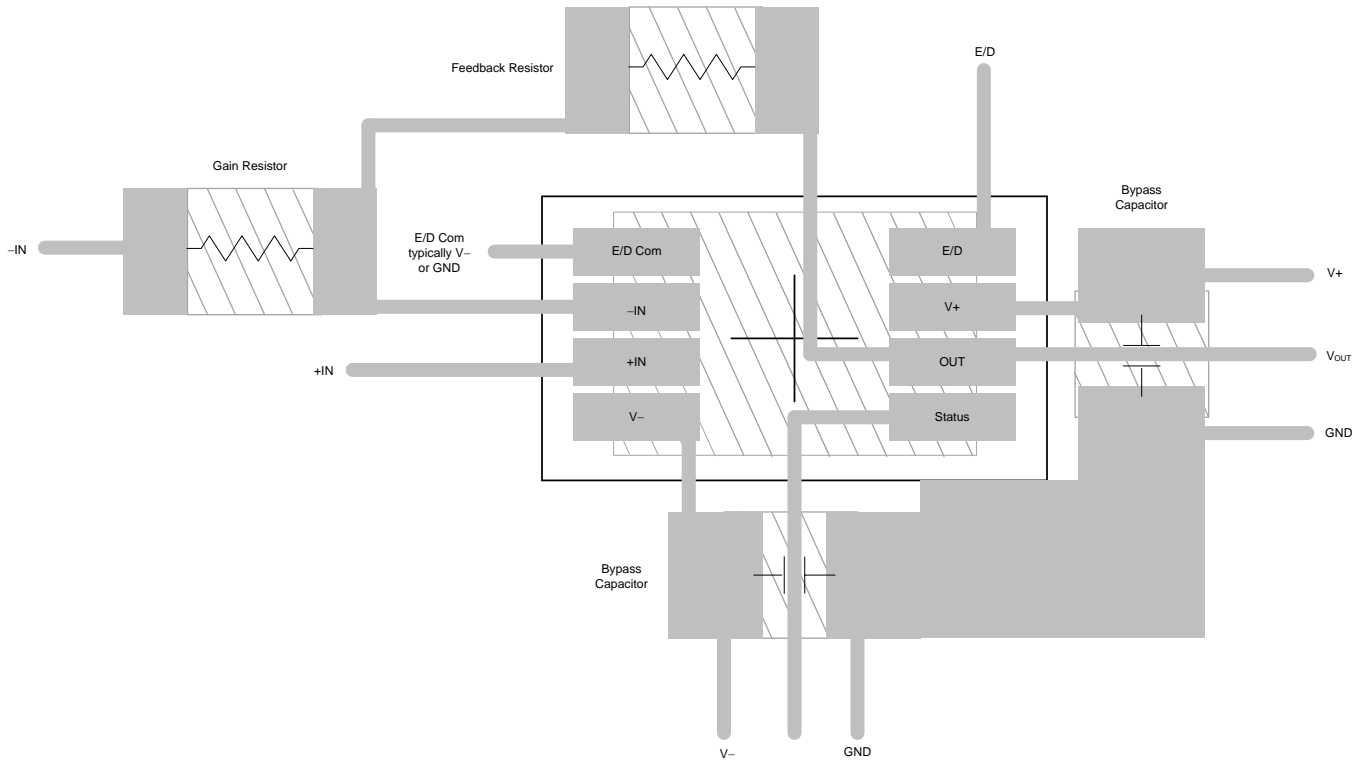

Figure 85. OPA454 Layout Example

12.3 Thermal Protection

Figure 86 shows the thermal shutdown behavior of a socketed OPA454 that internally dissipates 1 W. Unsoldered and in a socket, θ_{JA} of the DDA package is typically 128°C/W. With the socket at 25°C, the output stage temperature rises to the shutdown temperature of 150°C, which triggers automatic thermal shutdown of the device. The device remains in thermal shutdown (output is in a high-impedance state) until it cools to 130°C where it again is powered. This thermal protection hysteresis feature typically prevents the amplifier from leaving the safe operating area, even with a direct short from the output to ground or either supply. The rail-to-rail supply voltage at which catastrophic breakdown occurs is typically 135 V at 25°C. However, the absolute maximum specification is 120 V, and the OPA454 must not be allowed to exceed 120 V under any condition. Failure as a result of breakdown, caused by spiking currents into inductive loads (particularly with elevated supply voltage), is not prevented by the thermal protection architecture.

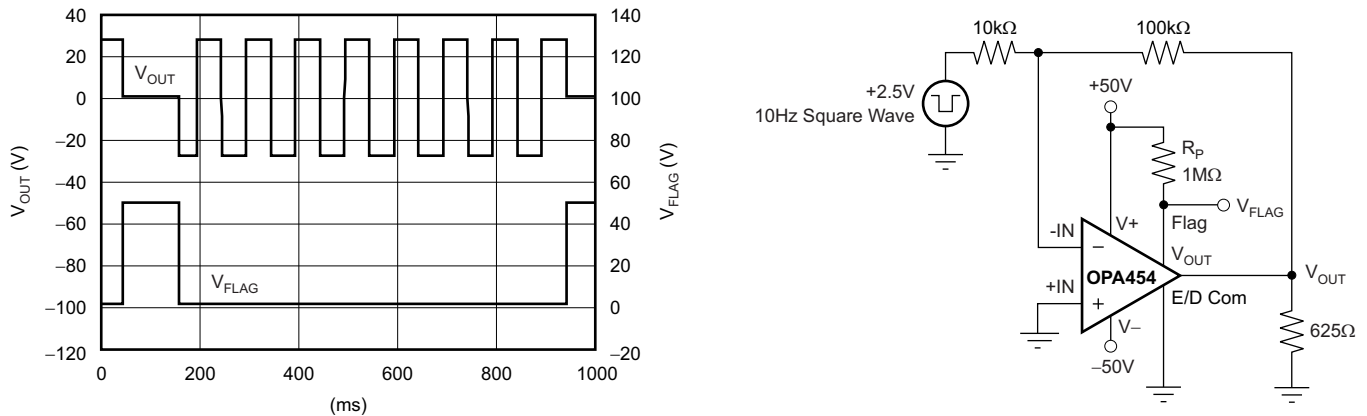

Figure 86. Thermal Shutdown

12.4 Power Dissipation

Power dissipation depends on power supply, signal, and load conditions. For DC signals, power dissipation is equal to the product of the output current times the voltage across the conducting output transistor, $P_D = I_L (V_S - V_O)$. Power dissipation can be minimized by using the lowest possible power-supply voltage necessary to assure the required output voltage swing.

For resistive loads, the maximum power dissipation occurs at a DC output voltage of one-half the power-supply voltage. Dissipation with AC signals is lower because the root-mean square (RMS) value determines heating. Application bulletin [SBOA022](#) explains how to calculate or measure dissipation with unusual loads or signals. For constant current source circuits, maximum power dissipation occurs at the minimum output voltage, as [Figure 87](#) shows.

The OPA454 can supply output currents of 25 mA and larger. Supplying this amount of current presents no problem for some op amps operating from ± 15 -V supplies. However, with high supply voltages, internal power dissipation of the op amp can be quite high. Operation from a single power supply (or unbalanced power supplies) can produce even greater power dissipation because a large voltage is impressed across the conducting output transistor. Applications with high power dissipation may require a heatsink or a heat spreader.

Power Dissipation (continued)

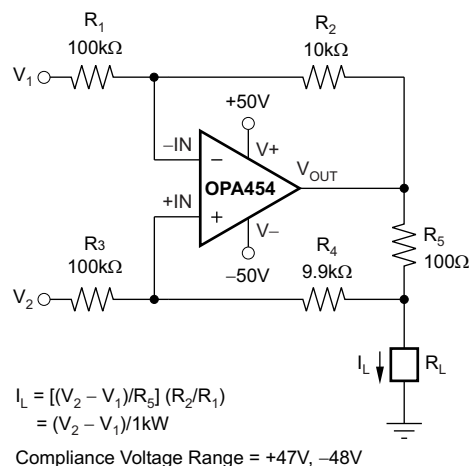

NOTE: $R_1 = R_3$ and $R_2 = R_4 + R_5$.

Figure 87. Precision Voltage-to-Current Converter With Differential Inputs

12.5 Heatsinking

Power dissipated in the OPA454 causes the junction temperature to rise. For reliable operation, junction temperature must be limited to 125°C, maximum. Maintaining a lower junction temperature always results in higher reliability. Some applications require a heatsink to assure that the maximum operating junction temperature is not exceeded. Junction temperature can be determined according to Equation 3:

$$T_J = T_A + P_D \theta_{JA} \tag{3}$$

Package thermal resistance, θ_{JA} , is affected by mounting techniques and environments. Poor air circulation and use of sockets can significantly increase thermal resistance to the ambient environment. Many op amps placed closely together also increase the surrounding temperature. Best thermal performance is achieved by soldering the op amp onto a circuit board with wide printed circuit traces to allow greater conduction through the op amp leads. Increasing circuit board copper area to approximately 0.5 in² decreases thermal resistance; however, minimal improvement occurs beyond 0.5 in², as shown in Figure 88.

For additional information on determining heatsink requirements, consult Application Bulletin SBOA021 (available for download at www.ti.com).

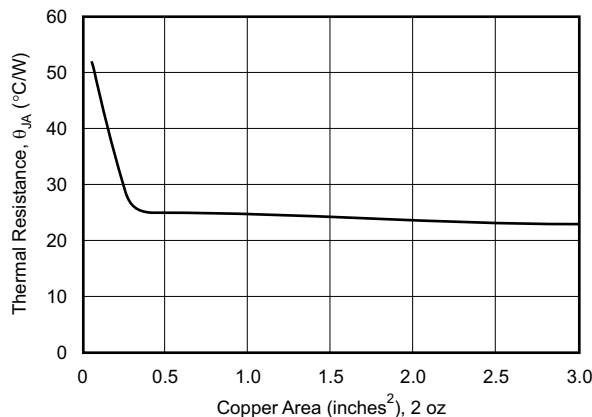

Figure 88. Thermal Resistance vs Circuit Board Copper Area

13 Device and Documentation Support

13.1 Device Support

13.1.1 Development Support

13.1.1.1 TINA-TI™ (Free Software Download)

TINA™ is a simple, powerful, and easy-to-use circuit simulation program based on a SPICE engine. TINA-TI™ is a free, fully-functional version of the TINA software, preloaded with a library of macro models in addition to a range of both passive and active models. TINA-TI provides all the conventional dc, transient, and frequency domain analysis of SPICE, as well as additional design capabilities.

Available as a [free download](#) from the Analog eLab Design Center, TINA-TI offers extensive post-processing capability that allows users to format results in a variety of ways. Virtual instruments offer the ability to select input waveforms and probe circuit nodes, voltages, and waveforms, creating a dynamic quick-start tool.

NOTE

These files require that either the TINA software (from DesignSoft™) or TINA-TI software be installed. Download the free TINA-TI software from the [TINA-TI folder](#).

13.1.1.2 TI Precision Designs

TI Precision Designs are analog solutions created by TI's precision analog applications experts and offer the theory of operation, component selection, simulation, complete PCB schematic and layout, bill of materials, and measured performance of many useful circuits. TI Precision Designs are available online at <http://www.ti.com/ww/en/analog/precision-designs/>.

13.1.1.3 WEBENCH® Filter Designer

[WEBENCH® Filter Designer](#) is a simple, powerful, and easy-to-use active filter design program. The WEBENCH Filter Designer lets you create optimized filter designs using a selection of TI operational amplifiers and passive components from TI's vendor partners.

Available as a web-based tool from the WEBENCH® Design Center, [WEBENCH® Filter Designer](#) allows you to design, optimize, and simulate complete multistage active filter solutions within minutes.

13.2 Documentation Support

13.2.1 Related Documentation

The following documents are relevant to using the OPA454, and recommended for reference. All are available for download at www.ti.com unless otherwise noted.

- Application bulletin AB-038: *Heat Sinking—TO-3 Thermal Model*, [SBOA021](#)
- Application bulletin AB-039: *Power Amplifier Stress and Power Handling Limitations*, [SBOA022](#)
- Application bulletin AB-045: *Op Amp Performance Analysis*, [SBOA054](#)
- Application bulletin AB-067: *Single-Supply Operation of Operational Amplifiers*, [SBOA059](#)
- Application bulletin AB-105: *Tuning in Amplifiers*, [SBOA067](#).
- Technical brief: *PowerPAD Thermally-Enhanced Package*, [SLMA002](#).

13.3 Community Resources

The following links connect to TI community resources. Linked contents are provided "AS IS" by the respective contributors. They do not constitute TI specifications and do not necessarily reflect TI's views; see TI's [Terms of Use](#).

TI E2E™ Online Community *TI's Engineer-to-Engineer (E2E) Community*. Created to foster collaboration among engineers. At e2e.ti.com, you can ask questions, share knowledge, explore ideas and help solve problems with fellow engineers.

Design Support *TI's Design Support* Quickly find helpful E2E forums along with design support tools and contact information for technical support.

13.4 Trademarks

PowerPAD, TINA-TI, E2E are trademarks of Texas Instruments.

WEBENCH is a registered trademark of Texas Instruments.

TINA, DesignSoft are trademarks of DesignSoft, Inc.

All other trademarks are the property of their respective owners.

13.5 Electrostatic Discharge Caution



These devices have limited built-in ESD protection. The leads should be shorted together or the device placed in conductive foam during storage or handling to prevent electrostatic damage to the MOS gates.

13.6 Glossary

[SLYZ022](#) — *TI Glossary*.

This glossary lists and explains terms, acronyms, and definitions.

14 Mechanical, Packaging, and Orderable Information

The following pages include mechanical, packaging, and orderable information. This information is the most current data available for the designated devices. This data is subject to change without notice and revision of this document. For browser-based versions of this data sheet, refer to the left-hand navigation.

PACKAGING INFORMATION

Orderable Device	Status (1)	Package Type	Package Drawing	Pins	Package Qty	Eco Plan (2)	Lead finish/ Ball material (6)	MSL Peak Temp (3)	Op Temp (°C)	Device Marking (4/5)	Samples
OPA454AIDDA	ACTIVE	SO PowerPAD	DDA	8	75	RoHS & Green	NIPDAU	Level-2-260C-1 YEAR	-55 to 125	OPA454	Samples
OPA454AIDDAG4	ACTIVE	SO PowerPAD	DDA	8	75	RoHS & Green	NIPDAU	Level-2-260C-1 YEAR	-55 to 125	OPA454	Samples
OPA454AIDDAR	ACTIVE	SO PowerPAD	DDA	8	2500	RoHS & Green	NIPDAU	Level-2-260C-1 YEAR	-55 to 125	OPA454	Samples
OPA454AIDDARG4	ACTIVE	SO PowerPAD	DDA	8	2500	RoHS & Green	NIPDAU	Level-2-260C-1 YEAR	-55 to 125	OPA454	Samples

(1) The marketing status values are defined as follows:

ACTIVE: Product device recommended for new designs.

LIFEBUY: TI has announced that the device will be discontinued, and a lifetime-buy period is in effect.

NRND: Not recommended for new designs. Device is in production to support existing customers, but TI does not recommend using this part in a new design.

PREVIEW: Device has been announced but is not in production. Samples may or may not be available.

OBSOLETE: TI has discontinued the production of the device.

(2) **RoHS:** TI defines "RoHS" to mean semiconductor products that are compliant with the current EU RoHS requirements for all 10 RoHS substances, including the requirement that RoHS substance do not exceed 0.1% by weight in homogeneous materials. Where designed to be soldered at high temperatures, "RoHS" products are suitable for use in specified lead-free processes. TI may reference these types of products as "Pb-Free".

RoHS Exempt: TI defines "RoHS Exempt" to mean products that contain lead but are compliant with EU RoHS pursuant to a specific EU RoHS exemption.

Green: TI defines "Green" to mean the content of Chlorine (Cl) and Bromine (Br) based flame retardants meet JS709B low halogen requirements of <=1000ppm threshold. Antimony trioxide based flame retardants must also meet the <=1000ppm threshold requirement.

(3) MSL, Peak Temp. - The Moisture Sensitivity Level rating according to the JEDEC industry standard classifications, and peak solder temperature.

(4) There may be additional marking, which relates to the logo, the lot trace code information, or the environmental category on the device.

(5) Multiple Device Markings will be inside parentheses. Only one Device Marking contained in parentheses and separated by a "-" will appear on a device. If a line is indented then it is a continuation of the previous line and the two combined represent the entire Device Marking for that device.

(6) Lead finish/Ball material - Orderable Devices may have multiple material finish options. Finish options are separated by a vertical ruled line. Lead finish/Ball material values may wrap to two lines if the finish value exceeds the maximum column width.

Important Information and Disclaimer:The information provided on this page represents TI's knowledge and belief as of the date that it is provided. TI bases its knowledge and belief on information provided by third parties, and makes no representation or warranty as to the accuracy of such information. Efforts are underway to better integrate information from third parties. TI has taken and

continues to take reasonable steps to provide representative and accurate information but may not have conducted destructive testing or chemical analysis on incoming materials and chemicals. TI and TI suppliers consider certain information to be proprietary, and thus CAS numbers and other limited information may not be available for release.

In no event shall TI's liability arising out of such information exceed the total purchase price of the TI part(s) at issue in this document sold by TI to Customer on an annual basis.

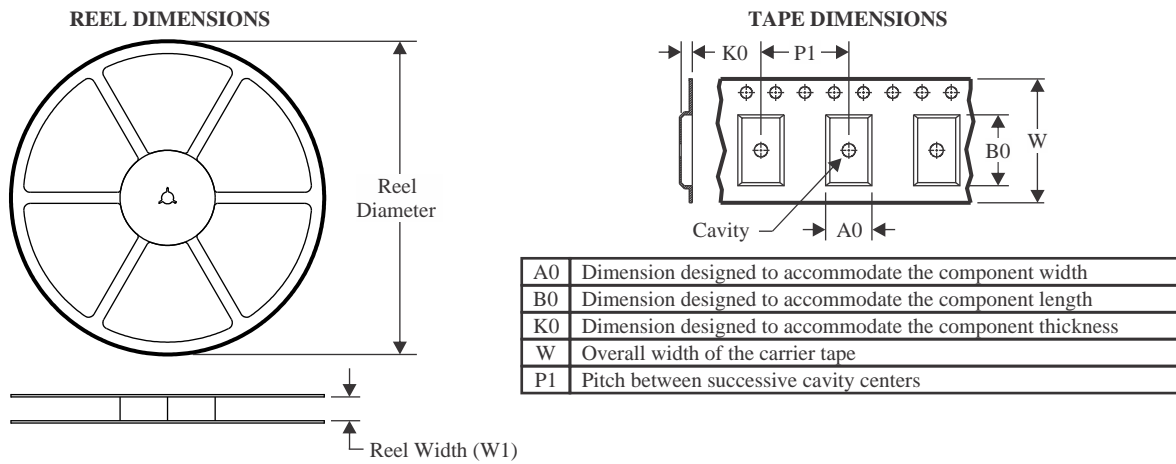
TAPE AND REEL INFORMATION

QUADRANT ASSIGNMENTS FOR PIN 1 ORIENTATION IN TAPE

*All dimensions are nominal

Device	Package Type	Package Drawing	Pins	SPQ	Reel Diameter (mm)	Reel Width W1 (mm)	A0 (mm)	B0 (mm)	K0 (mm)	P1 (mm)	W (mm)	Pin1 Quadrant
OPA454AIDDAR	SO PowerPAD	DDA	8	2500	330.0	12.4	6.4	5.2	2.1	8.0	12.0	Q1

TAPE AND REEL BOX DIMENSIONS

*All dimensions are nominal

Device	Package Type	Package Drawing	Pins	SPQ	Length (mm)	Width (mm)	Height (mm)
OPA454AIDDAR	SO PowerPAD	DDA	8	2500	356.0	356.0	35.0

TUBE



*All dimensions are nominal

Device	Package Name	Package Type	Pins	SPQ	L (mm)	W (mm)	T (μm)	B (mm)
OPA454AIDDA	DDA	HSOIC	8	75	506.6	8	3940	4.32
OPA454AIDDAG4	DDA	HSOIC	8	75	506.6	8	3940	4.32

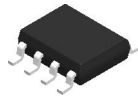

Images above are just a representation of the package family, actual package may vary.
Refer to the product data sheet for package details.

DDA0008J



PACKAGE OUTLINE

PowerPAD™ SOIC - 1.7 mm max height

PLASTIC SMALL OUTLINE

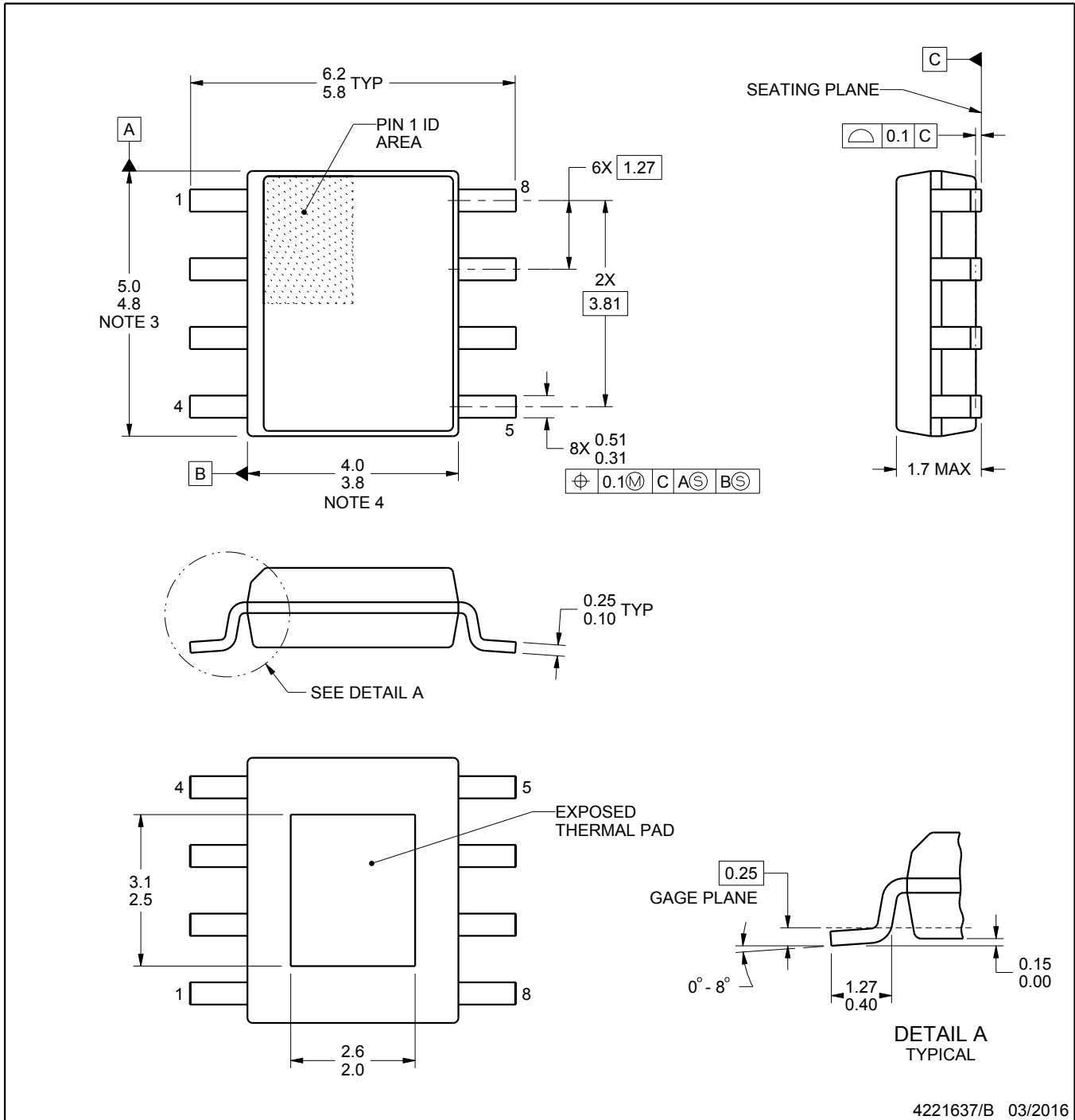

PowerPAD is a trademark of Texas Instruments.

NOTES:

1. All linear dimensions are in millimeters. Any dimensions in parenthesis are for reference only. Dimensioning and tolerancing per ASME Y14.5M.
2. This drawing is subject to change without notice.
3. This dimension does not include mold flash, protrusions, or gate burrs. Mold flash, protrusions, or gate burrs shall not exceed 0.15 mm per side.
4. This dimension does not include interlead flash. Interlead flash shall not exceed 0.25 mm per side.
5. Reference JEDEC registration MS-012, variation BA.

EXAMPLE BOARD LAYOUT

DDA0008J

PowerPAD™ SOIC - 1.7 mm max height

PLASTIC SMALL OUTLINE

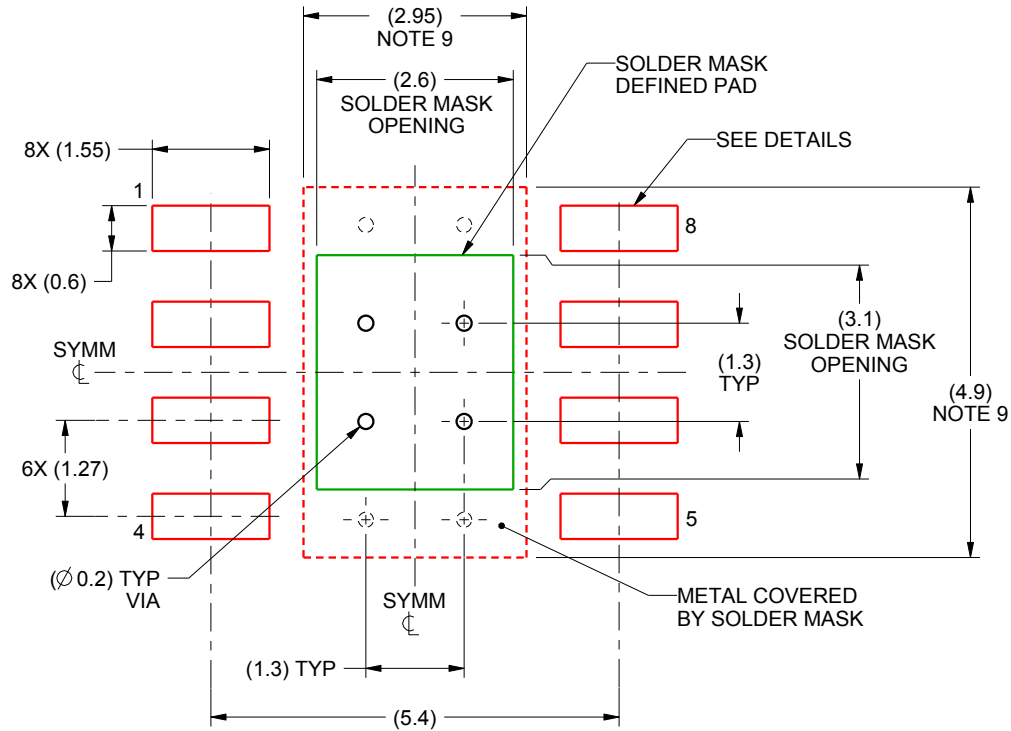

LAND PATTERN EXAMPLE
SCALE:10X

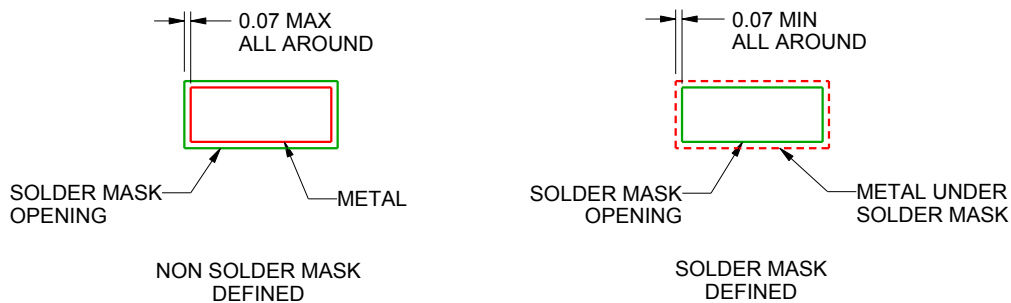

SOLDER MASK DETAILS

4221637/B 03/2016

NOTES: (continued)

6. Publication IPC-7351 may have alternate designs.
7. Solder mask tolerances between and around signal pads can vary based on board fabrication site.
8. This package is designed to be soldered to a thermal pad on the board. For more information, see Texas Instruments literature numbers SLMA002 (www.ti.com/lit/slma002) and SLMA004 (www.ti.com/lit/slma004).
9. Size of metal pad may vary due to creepage requirement.

EXAMPLE STENCIL DESIGN

DDA0008J

PowerPAD™ SOIC - 1.7 mm max height

PLASTIC SMALL OUTLINE

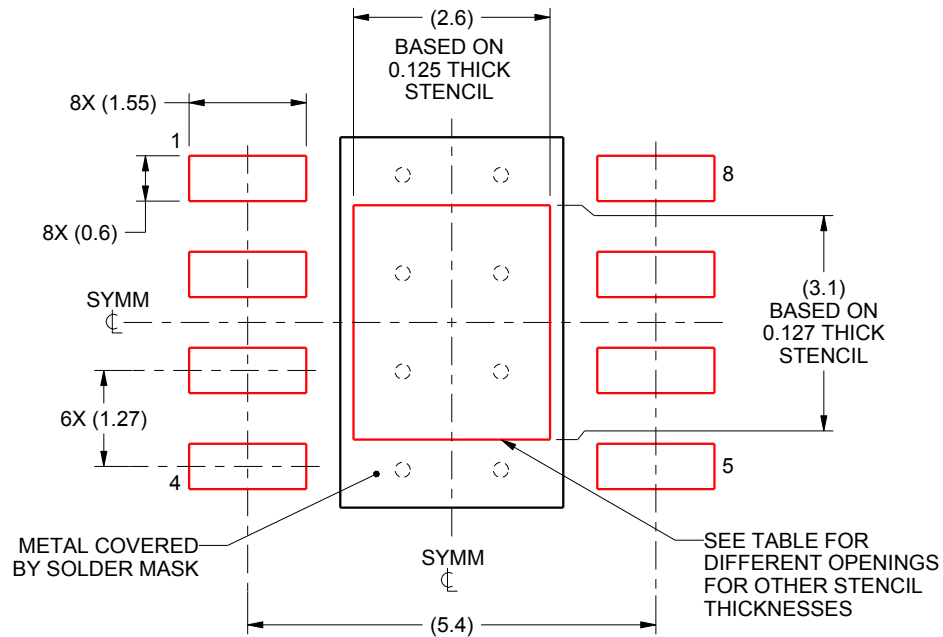

SOLDER PASTE EXAMPLE
EXPOSED PAD
100% PRINTED SOLDER COVERAGE BY AREA
SCALE:10X

STENCIL THICKNESS	SOLDER STENCIL OPENING
0.1	2.91 X 3.47
0.125	2.6 X 3.1 (SHOWN)
0.150	2.37 X 2.83
0.175	2.20 X 2.62

4221637/B 03/2016

NOTES: (continued)

10. Laser cutting apertures with trapezoidal walls and rounded corners may offer better paste release. IPC-7525 may have alternate design recommendations.
11. Board assembly site may have different recommendations for stencil design.

IMPORTANT NOTICE AND DISCLAIMER

TI PROVIDES TECHNICAL AND RELIABILITY DATA (INCLUDING DATA SHEETS), DESIGN RESOURCES (INCLUDING REFERENCE DESIGNS), APPLICATION OR OTHER DESIGN ADVICE, WEB TOOLS, SAFETY INFORMATION, AND OTHER RESOURCES "AS IS" AND WITH ALL FAULTS, AND DISCLAIMS ALL WARRANTIES, EXPRESS AND IMPLIED, INCLUDING WITHOUT LIMITATION ANY IMPLIED WARRANTIES OF MERCHANTABILITY, FITNESS FOR A PARTICULAR PURPOSE OR NON-INFRINGEMENT OF THIRD PARTY INTELLECTUAL PROPERTY RIGHTS.

These resources are intended for skilled developers designing with TI products. You are solely responsible for (1) selecting the appropriate TI products for your application, (2) designing, validating and testing your application, and (3) ensuring your application meets applicable standards, and any other safety, security, regulatory or other requirements.

These resources are subject to change without notice. TI grants you permission to use these resources only for development of an application that uses the TI products described in the resource. Other reproduction and display of these resources is prohibited. No license is granted to any other TI intellectual property right or to any third party intellectual property right. TI disclaims responsibility for, and you will fully indemnify TI and its representatives against, any claims, damages, costs, losses, and liabilities arising out of your use of these resources.

TI's products are provided subject to [TI's Terms of Sale](#) or other applicable terms available either on ti.com or provided in conjunction with such TI products. TI's provision of these resources does not expand or otherwise alter TI's applicable warranties or warranty disclaimers for TI products.

TI objects to and rejects any additional or different terms you may have proposed.

Mailing Address: Texas Instruments, Post Office Box 655303, Dallas, Texas 75265
Copyright © 2022, Texas Instruments Incorporated