

## 5V 输入或 3.3V 输入，3A 完全集成转换器

查询样品: **TPS51313**

### 特性

- 输入电压 **V<sub>IN</sub>** 范围: **3.1V 至 5.5V**
- 偏置电压 **V<sub>CC</sub>** 范围: **3.1V 至 5.5V**
- 输出电压范围: **0.6V 至 3.3V**
- **0.6V, 1%** 电压基准精度
- 开关频率: **1MHz**
- 无需外部补偿
- 固定电压伺服器软启动功能
- 过热保护

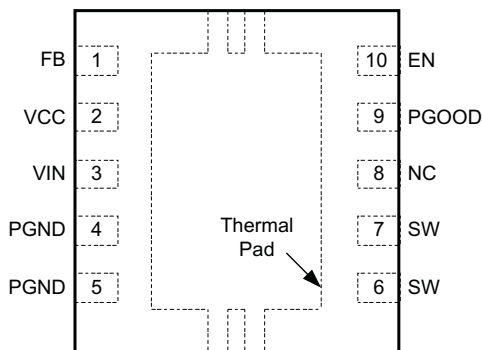

### 应用范围

- 离散图形 **PCIe<sup>®</sup> PEX** 轨
- 低压负载点 (**POL**) 电源轨

### 说明

TPS51313 是一款针对低压负载点应用的易于使用的、完全集成、同步降压转换器。它被设计成符合 NVIDIA™ OpenVreg 类型 0 技术规范，其中包括对封装和封装尺寸的要求。它在输出电压介于 0.6V 至 3.3V 之间时支持 3A（最大值）直流输出电流。D-CAP2™ 模式适应、恒定接通时间控制（开关频率 1MHz）可在使用全陶瓷输出电容器设计时实现小封装尺寸并提供一个低外部组件数量。此器件还在轻负载条件下特有自动跳跃功能、预偏置启动和内部固定软启动时间。当器件被禁用时，输出电容器通过内部电阻器放电。TPS51313 采用 3mm x 3mm, 10 引脚 DRC 封装（符合 RoHs 环保标准且无铅），额定温度范围为 -10°C 至 85°C。

### 简化的应用

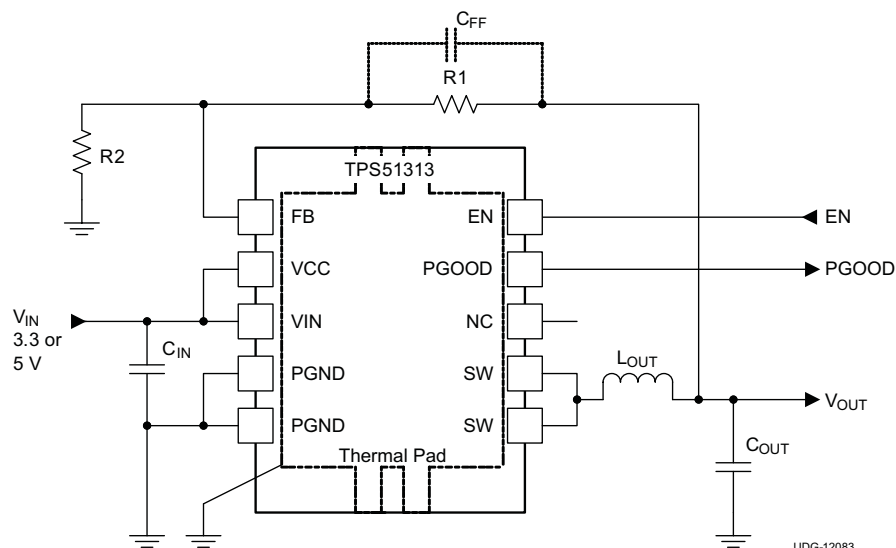

Please be aware that an important notice concerning availability, standard warranty, and use in critical applications of Texas Instruments semiconductor products and disclaimers thereto appears at the end of this data sheet.

D-CAP2 is a trademark of Texas Instruments.

NVIDIA is a trademark of NVIDIA, Incorporated.

PCIe is a registered trademark of PLX Technology, Inc.

# TPS51313

ZHCSAE8 –SEPTEMBER 2012

[www.ti.com.cn](http://www.ti.com.cn)



This integrated circuit can be damaged by ESD. Texas Instruments recommends that all integrated circuits be handled with appropriate precautions. Failure to observe proper handling and installation procedures can cause damage.

ESD damage can range from subtle performance degradation to complete device failure. Precision integrated circuits may be more susceptible to damage because very small parametric changes could cause the device not to meet its published specifications.

## ORDERING INFORMATION<sup>(1)</sup>

T <sub>A</sub>	PACKAGE	ORDERABLE DEVICE NUMBER	PINS	OUTPUT SUPPLY	MINIMUM QUANTITY	ECO PLAN
-10°C to 85°C	Plastic SON (DRC)	TPS51313DRCR	10	Tape and reel	3000	Green (RoHS and no Pb/Br)
		TPS51313DRCT		Mini reel	250	

(1) For the most current package and ordering information see the Package Option Addendum at the end of this document, or see the TI web site at [www.ti.com](http://www.ti.com).

## ABSOLUTE MAXIMUM RATINGS<sup>(1)</sup>

		VALUE		UNIT
		MIN	MAX	
Input voltage range <sup>(2)</sup>	VIN, VCC	-0.3	6.0	V
	SW	-2.0	6.0	
	SW (transient 20nsec)	-3.0	8.5	
	EN	-0.3	6.0	
	FB	-1	3.6	
Output voltage range <sup>(2)</sup>	PGOOD	-0.3	6.0	V
Junction temperature, T <sub>J</sub>			125	°C
Storage temperature, T <sub>stg</sub>		-55	150	°C

- (1) Stresses beyond those listed under "absolute maximum ratings" may cause permanent damage to the device. These are stress ratings only and functional operation of the device at these or any other conditions beyond those indicated under "recommended operating conditions" is not implied. Exposure to absolute-maximum-rated conditions for extended periods may affect device reliability.
- (2) All voltage values are with respect to the network ground terminal unless otherwise noted.

## THERMAL INFORMATION

THERMAL METRIC <sup>(1)</sup>		TPS51313	UNITS
		DRC (10-PIN)	
θ <sub>JA</sub>	Junction-to-ambient thermal resistance	42.4	°C/W
θ <sub>JCtop</sub>	Junction-to-case (top) thermal resistance	53.9	
θ <sub>JB</sub>	Junction-to-board thermal resistance	18.1	
ψ <sub>JT</sub>	Junction-to-top characterization parameter	1.1	
ψ <sub>JB</sub>	Junction-to-board characterization parameter	18.3	
θ <sub>JCbot</sub>	Junction-to-case (bottom) thermal resistance	6.3	

(1) 有关传统和新的热 度量的更多信息，请参阅IC 封装热度量应用报告，[SPRA953](#)。

## RECOMMENDED OPERATING CONDITIONS

		MIN	MAX	UNIT
Input voltage range	VIN, VCC	-0.1	5.5	V
	SW	-0.1	5.5	
	EN	-0.1	5.5	
	FB	-0.1	3.5	
Output voltage range	PGOOD	-0.1	5.5	V
Operating free-air temperature, T <sub>A</sub>		-10	85	°C

**ELECTRICAL CHARACTERISTICS**

Over operating free-air temperature range,  $V_{IN} = 5\text{ V}$ ,  $V_{CC} = 5\text{ V}$ ,  $V_{EN} = 3.3\text{ V}$  (unless otherwise noted).

PARAMETER		TEST CONDITION	MIN	TYP	MAX	UNIT
<b>SUPPLY VOLTAGE</b>						
$V_{IN}$	Supply voltage		3.1		5.5	V
$V_{CC}$	Supply voltage		3.1		5.5	V
<b>SUPPLY CURRENT</b>						
$I_{IN}$	Input voltage supply current	EN = High			100	$\mu\text{A}$
$I_{SD}$	Input voltage shutdown current	EN = Low			12	$\mu\text{A}$
$I_{VCC(in)}$	VCC supply current	EN = High		700		$\mu\text{A}$
$I_{VCC(sd)}$	VCC shutdown current	EN = Low, $T_A = 25^\circ\text{C}$			20	$\mu\text{A}$
<b>VFB REFERENCE VOLTAGE</b>						
$V_{FBREF}$	Reference voltage			0.6		V
$V_{FBREFTOL}$	Reference voltage tolerance	$T_A = 25^\circ\text{C}$	-1%		1%	
$I_{FB}$	Feedback pin leakage current		-100		100	nA
<b>SMPS FREQUENCY</b>						
$f_{SW}$	Switching frequency	EVM close loop measurement. $V_{IN} = 5\text{ V}$ , $V_{OUT} = 1.05\text{ V}$ , $I_{OUT} = 3\text{ A}$		1		MHz
$t_{OFF(min)}$	Minimum off-time		110	190	270	ns
$t_{DEAD}$	Deadtime <sup>(1)</sup>	SW node high, $V_{IN} = 5\text{ V}$		9		ns
		SW node low, $V_{IN} = 5\text{ V}$		10		
<b>LOGIC THRESHOLD</b>						
$V_{LL}$	EN low-level voltage				0.8	V
$V_{LH}$	EN high-level voltage		1.5			V
$I_{LLK}$	EN input leakage current	$V_{IN} = V_{CC} = 3.3\text{ V}$	-3	1	3	$\mu\text{A}$
<b>SOFT START</b>						
$t_{SS}$	Soft-start time <sup>(1)</sup>	$V_{FB}$ rising from 0 V to 0.6 V		300		$\mu\text{s}$
<b>PGOOD COMPARATOR</b>						
$V_{PGTH}$	PGOOD threshold	PGOOD out to higher w/r/t $V_{FB}$		130%		
		PGOOD out to lower w/r/t $V_{FB}$		50%		
$t_{PGDLY}$	PGOOD high delay time	Delay for PGOOD in, after EN = Hi		1.3		ms
$I_{PGLK}$	PGOOD leakage current		-1	0	1	$\mu\text{A}$
<b>CURRENT DETECTION</b>						
$I_{OCL}$	Current limit threshold	Valley current limit, $V_{IN} = V_{CC} = 3.3\text{ V}$ , $T_A = 25^\circ\text{C}$		4.8		A
<b>PROTECTIONS</b>						
$V_{IN\_UVLO}$	VIN UVLO threshold voltage	Wake-up	2.85	2.95	3.05	V
		Shutdown	2.6	2.7	2.8	
$V_{CC\_UVLO}$	VCC UVLO threshold voltage	Wake-up	2.85	2.95	3.05	
		Shutdown	2.6	2.7	2.8	
$V_{OVP}$	OVP threshold voltage	OVP detect voltage, overdrive = 100 mV		130%		
$t_{OVP}$	OVP delay time	Overdrive = 100 mV		1.9		$\mu\text{s}$
$V_{UVP}$	UVP threshold voltage	UVP detect voltage, overdrive = 100 mV		50%		
$t_{UVPDLY}$	UVP delay time	Overdrive = 100 mV		2.4		$\mu\text{s}$
<b>SW PULL DOWN</b>						
$R_{SWPD}$	Switch node pull down resistance	EN = Lo		260		$\Omega$
<b>THERMAL SHUTDOWN</b>						
$T_{SDN}$	Thermal shutdown threshold <sup>(1)</sup>	Shutdown temperature		145		$^\circ\text{C}$
		Hysteresis		20		

(1) Specified by design. Not production tested.

DEVICE INFORMATION  
Functional Block Diagram

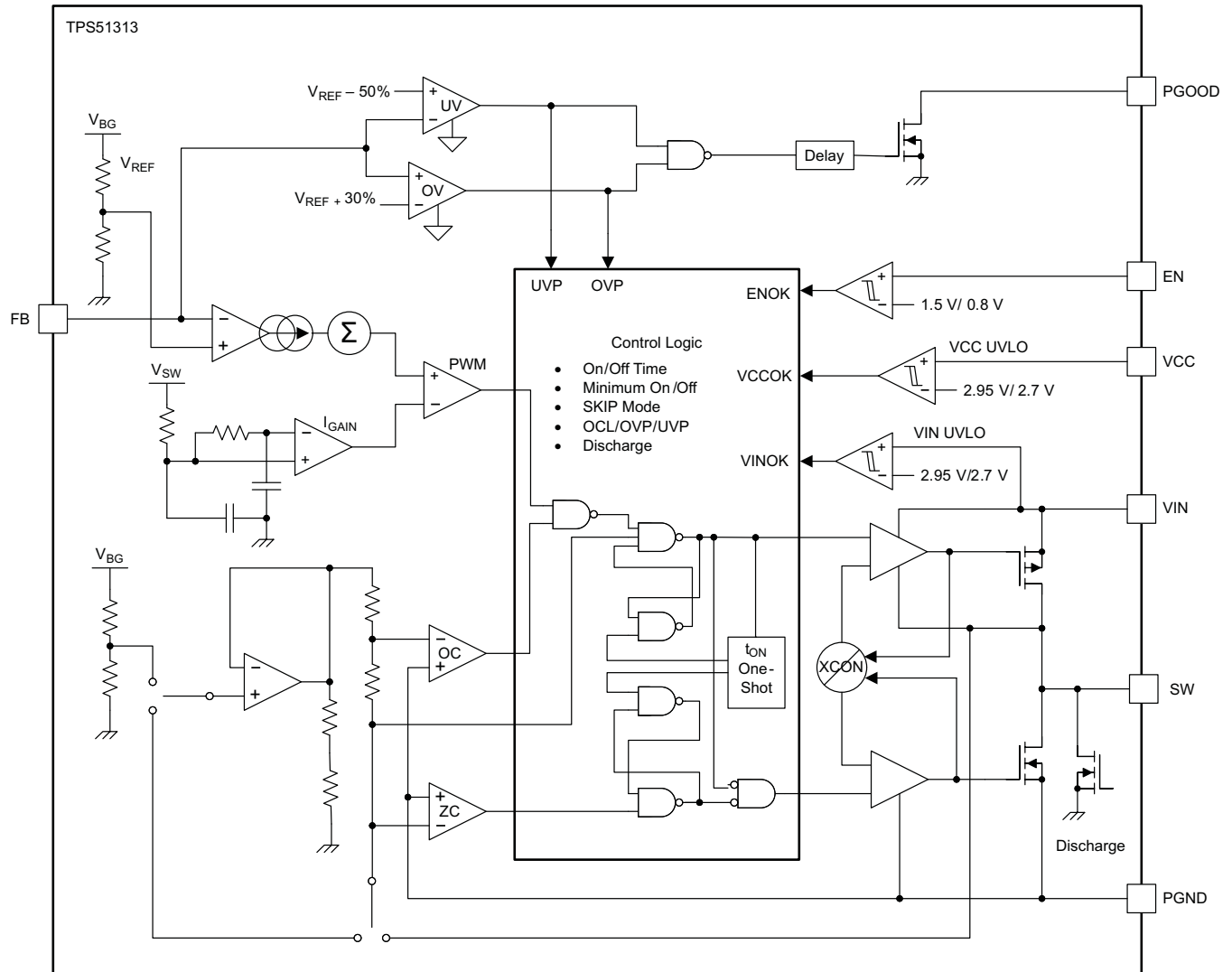

UDG-12112

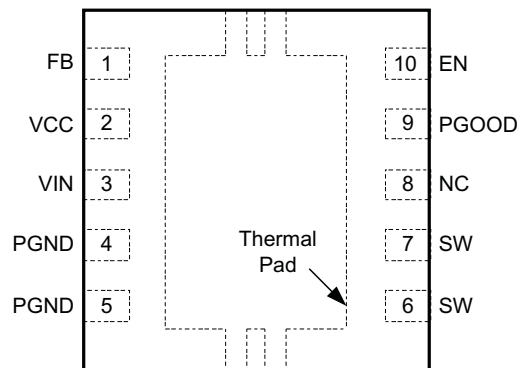
**DRC PACKAGE  
10 PINS  
(TOP VIEW)**

**PIN FUNCTIONS**

PIN		I/O	DESCRIPTION
NAME	NO.		
EN	10	I	Enable function for the switched-mode power supply (SMPS) (3.3-V logic compatible)
FB	1	I	Voltage feedback. Also used for OVP, UVP and PGOOD determination.
NC	8	I	No connect. Make no external connection to this pin.
PGND	4	I	Device ground
	5		
PGOOD	9	O	Power good indicator. Requires external pull-up resistor.
SW	6	I	Switching node output. Connect to external inductor. Also serve as current sensing negative input for over current protection purpose
	7		
VCC	2	I	Power supply for analog circuit.
VIN	3		Main power conversion input and gate-drive voltage supply for output FETs.
Thermal Pad			Connect to PGND.

TYPICAL CHARACTERISTICS

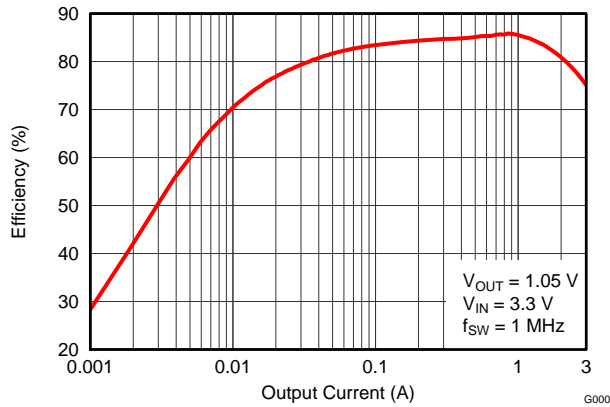

Figure 1. Efficiency vs. Output Current

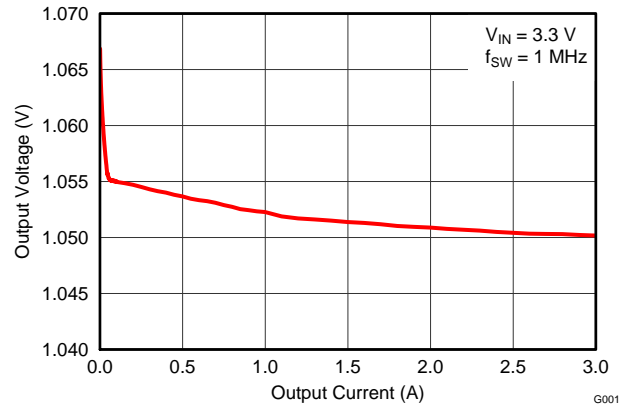

Figure 2. DC Load Regulation

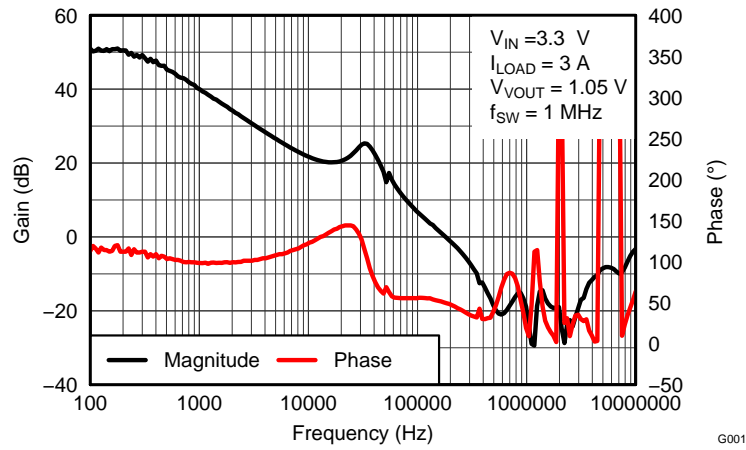

Figure 3. Bode Plot

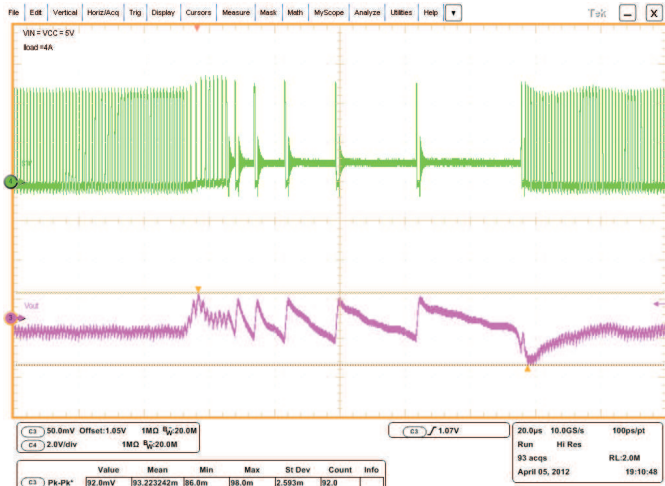

Figure 4. Fast 0-A to 3-A Transient Response

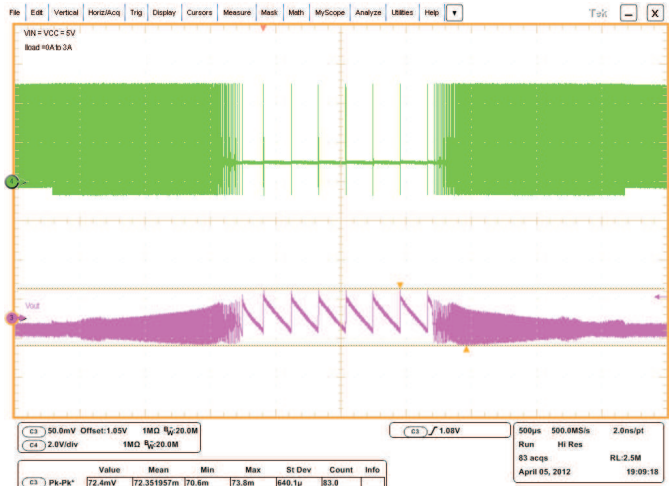

Figure 5. Slow 0-A to 3-A Transient Response

## APPLICATION INFORMATION

### Functional Overview

TPS51313 is a D-CAP2 mode adaptive on time converter with internal integrator. Monolithically integrate high side and low side FET supports output current to a maximum of 3-ADC. The converter automatically runs in discontinuous conduction mode to optimize light load efficiency. A switching frequency of 1-MHz enables optimization of the power train for the cost, size and efficiency performance of the design.

### PWM Operation

The PWM operation is comprised of three separate loops, A, B and C as shown in Figure 6.

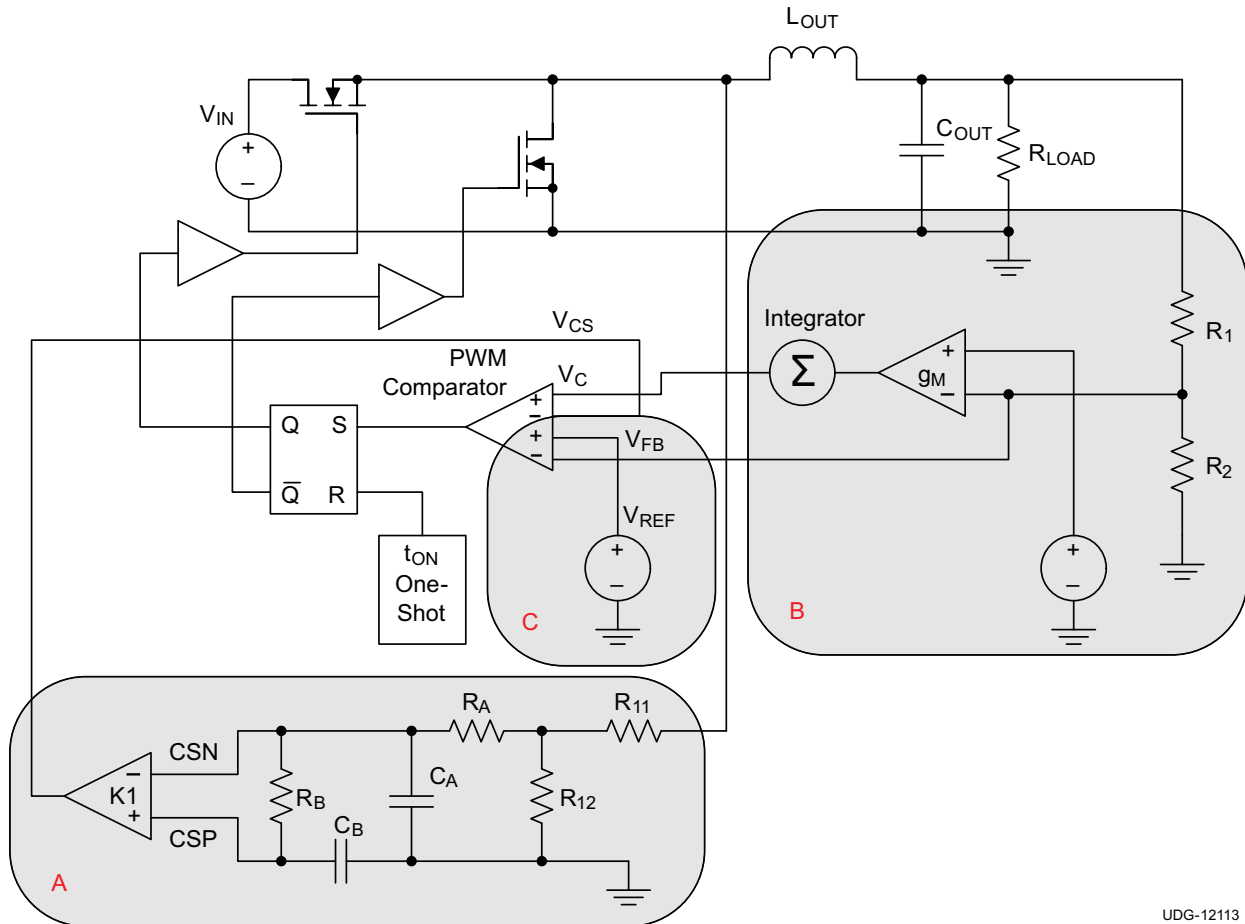

UDG-12113

Figure 6. PWM Operation

#### Internal Current Loop (A)

Loop A is the internal current loop. The current information is sampled, divided and averaged at the SW node. The RC time constant and the gain of the current sense amplifier is chosen to cover the wide range of power stage design intended for this application.

#### Internal Voltage Loop (B)

Loop B is the internal voltage loop. The feedback voltage information is compared to the voltage reference at the input of the  $g_M$  amplifier, the internal integrator is designed to provide a zero at the double pole location to boost phase margin at the desired crossover frequency.

### Fast Feedforward Loop (C)

Loop C is the additional loop that acts a direct fast feedforward loop to enhance the transient response.

In steady state operation as shown in Figure 7, the on time is initiated by the interaction of the three loops mentioned above. When the  $(V_C - V_{CS})$  is rising above threshold defined by  $(V_{FB} - V_{REF})$ , the PWM comparator issues the on time pulse after the propagation delay. The demand of on time occurs when the artificial current has reached the valley point. The load regulation is maintained by the integrator provided by the  $g_M$  amplifier and internal integrator.

In transient operation as shown in Figure 8, the benefit of this topology is becoming evident. In an all MLCC output configuration, especially when the output capacitance is low, when the load step is applied, the output voltage is immediately discharged to try to keep the load demand. The immediate reflection of the load demand is instantly reflected in the FB voltage. The  $(V_{FB} - V_{REF})$  is thus served as a termination voltage level for the  $(V_C - V_{CS})$ , thus modulating the initiation of the on time. The transient response can be improved further by amplifying the difference between  $V_{FB}$  and the  $V_{REF}$  reference.

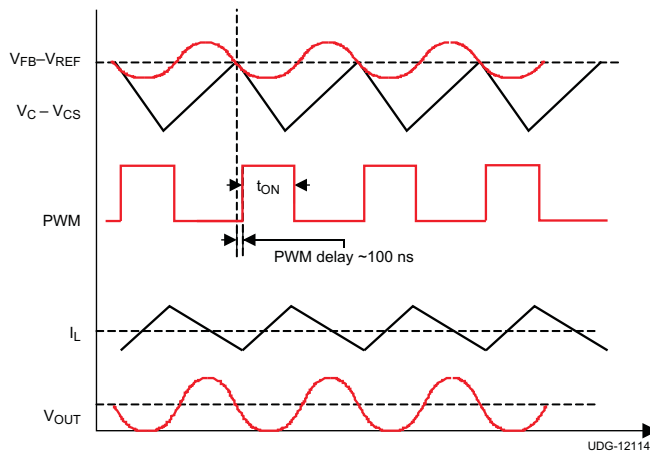

Figure 7. Steady-State Operation

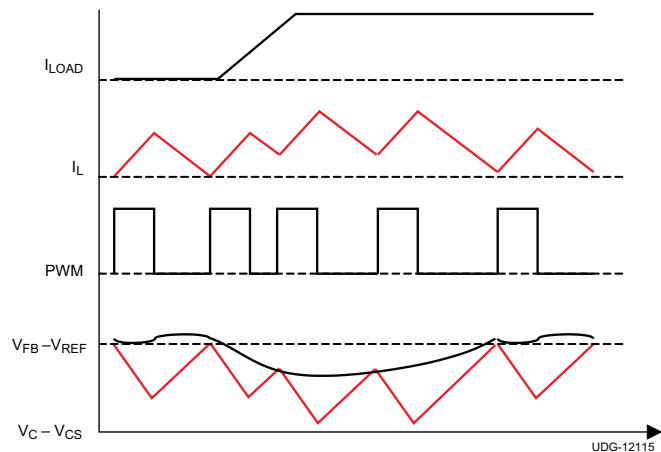

Figure 8. Transient Operation

### PWM Frequency

The TPS51313 operates at a switching frequency of 1 MHz.

### Light Load Power Saving Features

The TPS51313 offers an automatic pulse-skipping feature to provide excellent efficiency over the entire load range. The converter senses the current when the low-side FET is on and prevents negative current flow by turning off the low side FET. This saves power by eliminating re-circulation of the inductor current. When the bottom FET is turned off, the converter enters discontinuous mode, and the switching frequency decreases, reducing switching loss.

### Power Sequences

TPS51313 initiates the soft-start process when the EN, VIN and VCC pins are ready. The soft-start time 300  $\mu$ s when the reference voltage is between 0 V and 0.6 VREF. The actual output ramp-up time is the same as that of the VREF start-up time, which is 300  $\mu$ s.

### Power Good Signal

The TPS51313 has one open-drain power good (PGOOD) pin. During initial startup, there is a 1.3-ms power good high propagation delay after EN goes high. The PGOOD de-asserts when the EN is pulled low or an undervoltage condition on VCC or VIN or any other faults (such as V\_OUT, UVP, OCP, OVP) that require latch off action is detected.

### Protection Features

The TPS51313 offers many features to protect the converter power chain as well as the system electronics.



### Input Undervoltage Protection on $V_{CC}$ and $V_{IN}$ (UVLO)

The TPS51313 continuously monitor the voltage on the  $V_{CC}$  and  $V_{IN}$  to ensure the voltage level is high enough to bias the converter properly and to provide sufficient gate drive potential to maintain high efficiency for the converter. The converter starts with  $V_{CC}$  and  $V_{IN}$  approximately 2.95 V and has a nominal of 250 mV of hysteresis, assuming EN is above the logic threshold level. If the UVLO level is reached for either  $V_{CC}$  or  $V_{IN}$ , the converter transitions the SW node into a tri-state and remains off until the device is reset by both  $V_{CC}$  and  $V_{IN}$  reaches 2.95 V (nominal). The PGOOD is deasserted when UVLO is detected and remains low until the device is reset. The device resumes operation when VIN recovers to 2.95 V (nominal).

### Output Overvoltage Protection (OVP)

The TPS51313 has OVP protection circuit. An OVP event is detected when the FB voltage is approximately  $130\% \times 0.6V_{REF}$ . In this case, the converter de-asserts the PGOOD signal and performs the overvoltage protection function. The converter latches off both high-side and low-side FET (after a typical delay of 1.9  $\mu$ s) and remains in this state until the device is reset by EN, or  $V_{CC}$  or  $V_{IN}$ .

### Output Undervoltage Protection (UVP)

Output undervoltage protection works in conjunction with the current protection described in the [Overcurrent and Current Limit Protection](#) section. If the FB voltage drops below  $50\% \times 0.6 V_{REF}$ , after a delay of 2.4  $\mu$ s, the converter latches off. Undervoltage protection can be reset by EN,  $V_{CC}$  or  $V_{IN}$ .

### Overcurrent and Current Limit Protection

The TPS51313 provides an overcurrent protection function. The minimum OCP level is 4.8-A DC. When the current limit is exceeded for consecutive 9 cycles, the converter latches off and remains latched off until it is reset by EN,  $V_{CC}$  or  $V_{IN}$ .

The TPS51313 also provides current limit protection function. If the sense current is above the OCL setting, the converter delays the next on pulse until the current level drops below the OCL limit. Current limiting occurs on a pulse-by-pulse basis. During a fast or very fast overcurrent event, the output voltage tends to droop until the UVP limit is reached. Then the converter de-asserts the PGOOD signal, and latches off after a delay between 1  $\mu$ s and 2  $\mu$ s. The converter remains in this state until the device is reset by EN,  $V_{CC}$  or  $V_{IN}$ .

### Thermal Protection

The TPS51313 has an internal temperature sensor. When the die temperature reaches a nominal of 145°C, the device shuts down until the temperature cools by approximately 20°C. Then the converter restarts. The thermal shutdown is a non-latched behavior.

## REFERENCE DESIGN

### Application Schematic

This section describes a simplified design procedure for a discrete graphics processor PEX rail application using the TPS51313 converter. Figure 9 shows the application schematic..

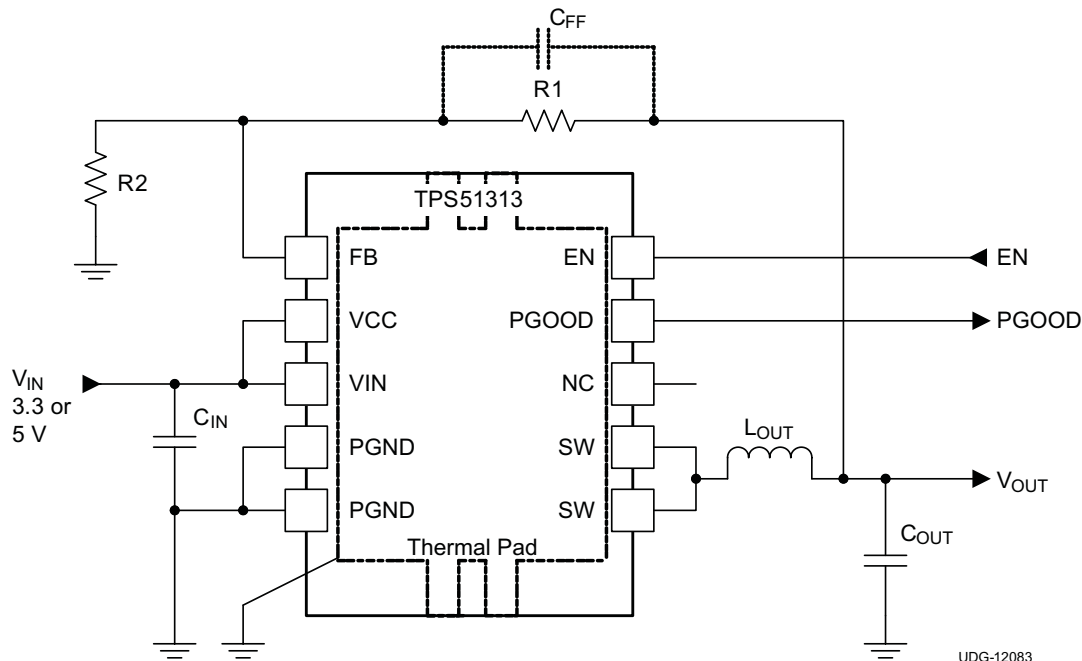

Figure 9. Reference Design Schematic

Table 1. Reference Design List of Materials

FUNCTION	MANUFACTURER	PART NUMBER
Output Inductor	Vishay	IHLP-1212AB-11
Ceramic Output Capacitors	Panasonic	ECJ2FB0J226M
	Murata	GRM21BR60J226ME39L

### Design Procedure

#### Step One. Determine the specifications.

. The PEX rail requirement provides the following key parameters.

- $V_{OUT} = 1.05\text{ V}$
- $I_{CC(max)} = 3\text{ A}$
- $\Delta I = 2\text{ A}$  (transient load step and release)
- $di/dt = 2.5\text{ A}/\mu\text{s}$

#### Step Two. Determine the system parameters.

The input voltage range and operating frequency are of primary interest. For example,

- $V_{IN} = V_{CC} = 3.3\text{ V}$
- $f_{SW} = 1\text{ MHz}$ .
- Maximum height of power chain components = 1.2 mm

### Step Three. Set the output voltage.

Use [Equation 1](#) to determine the output voltage.

$$V_{OUT} = V_{REF} \times \frac{(R1+R2)}{R2} \quad (1)$$

The output voltage is determined by 0.6-V voltage reference and the resistor dividers (R1 and R2). The output voltage is regulated to the FB pin. For this  $V_{OUT} = 1.05$  V, reference design, select  $R1 = 30$  k $\Omega$  and  $R2 = 40$  k $\Omega$ . (see [Figure 9](#)) To improve signal-to-noise performance of the converter, add a small feedforward capacitor (typically approximately 27 pF or less) in parallel with the upper resistor (R1).

### Step Four. Determine inductor value and choose inductor.

Smaller inductance yields better transient performance but the consequence is higher ripple and lower efficiency. Higher values have the opposite characteristics. It is common practice to limit the ripple current to 25% to 50% of the maximum current. In this case, use 40%:

$$I_{P-P} = 3A \times 0.4 = 1.2A$$

where

- $f_{SW} = 1$  MHz
  - $V_{IN} = 3.3$  V
  - $V_{OUT} = 1.05$  V
- (2)

$$L = \frac{V \times dT}{I_{P-P}} = \left( \frac{(V_{IN} - V_{OUT})}{I_{P-P}} \right) \times \left( \frac{V_{OUT}}{(f_{SW} \times V_{IN})} \right) = 0.596 \mu H \quad (3)$$

For this application, a 0.56- $\mu$ H, 18.7-m $\Omega$  inductor from Vishay with part number IHLP-1212AB-11 is chosen. Maximum height for this inductor is 1.2 mm.

### Step Five. Determine the output capacitance.

To determine  $C_{OUT}$  based on transient and stability requirement, first calculate the minimum output capacitance for a given transient.

[Equation 4](#) and [Equation 5](#) calculate the minimum output capacitance for meeting the transient requirement, which is 33.8- $\mu$ F assuming a  $\pm 3\%$  voltage allowance for load step and release.

$$C_{OUT(min\_under)} = \frac{L \times \Delta I_{LOAD(max)}^2 \times \left( \frac{V_{VOUT} \times t_{SW}}{V_{IN(min)}} + t_{MIN(off)} \right)}{2 \times \Delta V_{LOAD(insert)} \times \left( \left( \frac{V_{IN(min)} - V_{VOUT}}{V_{IN(min)}} \right) \times t_{SW} - t_{MIN(off)} \right) \times V_{VOUT}} \quad (4)$$

$$C_{OUT(min\_over)} = \frac{L_{OUT} \times (\Delta I_{LOAD(max)})^2}{2 \times \Delta V_{LOAD(release)} \times V_{VOUT}} \quad (5)$$

This design uses 3 22- $\mu$ F capacitors with consideration of the MLCC derating effect (60% derating for both AC and DC effect).

### Step Six. Establishing the internal compensation loop.

The TPS51313 is designed with an internal compensation loop. The internal integrator zero location is approximately 60 kHz. When the power stage double pole frequency contributed by the  $L_{OUT}$  and  $C_{OUT}$  is less than or equal to that of the zero frequency location, the converter is stable with sufficient margin.

### Step Seven. Select decoupling and peripheral components.

For TPS51313 peripheral capacitors use the following minimum value of ceramic capacitance, X5R or better temperature coefficient is recommended. Tighter tolerances and higher voltage ratings are always appropriate.

## TPS51313

ZHCSAE8 –SEPTEMBER 2012

[www.ti.com.cn](http://www.ti.com.cn)

$V_{CC}$  and  $V_{IN}$  decoupling  $\geq 2 \times 10 \mu\text{F}$ , 6.3 V

Pull up resistor on PGOOD = 100 k $\Omega$

### Step Eight. (Optional) Snubber design for optimizing maximum switch node ringing.

For TPS51313 layout design, if the maximum switch node voltage is above 8.5 V for 20 ns, snubber circuit is recommended to limit the maximum voltage to be within the absolute maximum voltage rating (see Absolute maximum rating table on page 2). A series combination of R and C (where the value of R is approximately 2.2  $\Omega$ , and the value of C is approximately 470 pF) from SW node to PGND can be added to achieve effective snubbing for SW node.

### Layout Considerations

Good layout is essential for stable power supply operation. Follow these guidelines for an efficient PCB layout.

- Widen the PGND connection area as much as possible.
- Place  $V_{IN}$ ,  $V_{CC}$  decoupling capacitors as close to the device as possible.
- Use wide traces for the VIN, SW and PGND pins. These nodes carry high current and also serve as heat sinks.
- Place FB and voltage setting dividers as close to the device as possible.

**PACKAGING INFORMATION**

Orderable Device	Status (1)	Package Type	Package Drawing	Pins	Package Qty	Eco Plan (2)	Lead finish/ Ball material (6)	MSL Peak Temp (3)	Op Temp (°C)	Device Marking (4/5)	Samples
TPS51313DRCR	ACTIVE	VSON	DRC	10	3000	RoHS & Green	NIPDAU	Level-1-260C-UNLIM	-10 to 85	S51313	<a href="#">Samples</a>
TPS51313DRCT	ACTIVE	VSON	DRC	10	250	RoHS & Green	NIPDAU	Level-1-260C-UNLIM	-10 to 85	S51313	<a href="#">Samples</a>

(1) The marketing status values are defined as follows:

**ACTIVE:** Product device recommended for new designs.

**LIFEBUY:** TI has announced that the device will be discontinued, and a lifetime-buy period is in effect.

**NRND:** Not recommended for new designs. Device is in production to support existing customers, but TI does not recommend using this part in a new design.

**PREVIEW:** Device has been announced but is not in production. Samples may or may not be available.

**OBSOLETE:** TI has discontinued the production of the device.

(2) **RoHS:** TI defines "RoHS" to mean semiconductor products that are compliant with the current EU RoHS requirements for all 10 RoHS substances, including the requirement that RoHS substance do not exceed 0.1% by weight in homogeneous materials. Where designed to be soldered at high temperatures, "RoHS" products are suitable for use in specified lead-free processes. TI may reference these types of products as "Pb-Free".

**RoHS Exempt:** TI defines "RoHS Exempt" to mean products that contain lead but are compliant with EU RoHS pursuant to a specific EU RoHS exemption.

**Green:** TI defines "Green" to mean the content of Chlorine (Cl) and Bromine (Br) based flame retardants meet JS709B low halogen requirements of <=1000ppm threshold. Antimony trioxide based flame retardants must also meet the <=1000ppm threshold requirement.

(3) MSL, Peak Temp. - The Moisture Sensitivity Level rating according to the JEDEC industry standard classifications, and peak solder temperature.

(4) There may be additional marking, which relates to the logo, the lot trace code information, or the environmental category on the device.

(5) Multiple Device Markings will be inside parentheses. Only one Device Marking contained in parentheses and separated by a "~" will appear on a device. If a line is indented then it is a continuation of the previous line and the two combined represent the entire Device Marking for that device.

(6) Lead finish/Ball material - Orderable Devices may have multiple material finish options. Finish options are separated by a vertical ruled line. Lead finish/Ball material values may wrap to two lines if the finish value exceeds the maximum column width.

**Important Information and Disclaimer:**The information provided on this page represents TI's knowledge and belief as of the date that it is provided. TI bases its knowledge and belief on information provided by third parties, and makes no representation or warranty as to the accuracy of such information. Efforts are underway to better integrate information from third parties. TI has taken and continues to take reasonable steps to provide representative and accurate information but may not have conducted destructive testing or chemical analysis on incoming materials and chemicals. TI and TI suppliers consider certain information to be proprietary, and thus CAS numbers and other limited information may not be available for release.

In no event shall TI's liability arising out of such information exceed the total purchase price of the TI part(s) at issue in this document sold by TI to Customer on an annual basis.



## GENERIC PACKAGE VIEW

**DRC 10**

**VSON - 1 mm max height**

3 x 3, 0.5 mm pitch

PLASTIC SMALL OUTLINE - NO LEAD

This image is a representation of the package family, actual package may vary.  
Refer to the product data sheet for package details.

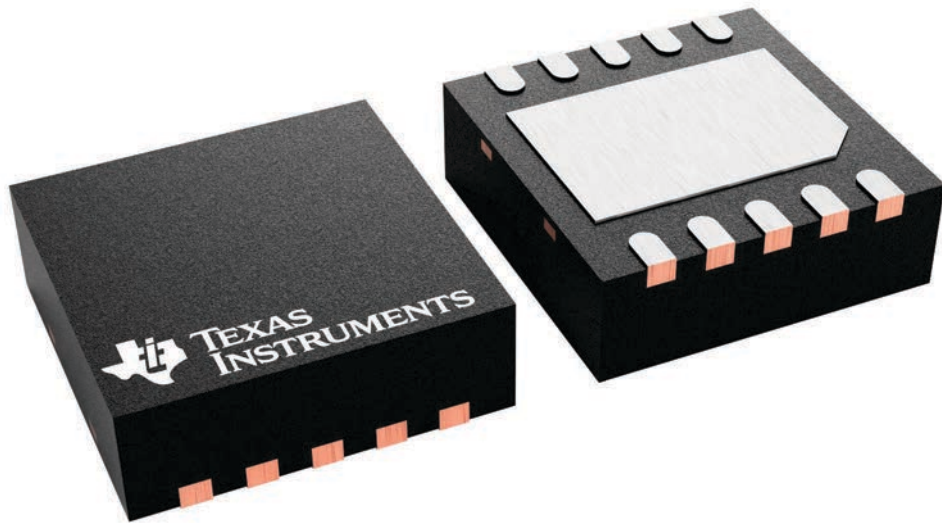

4226193/A





# EXAMPLE BOARD LAYOUT

DRC0010J

VSON - 1 mm max height

PLASTIC SMALL OUTLINE - NO LEAD



LAND PATTERN EXAMPLE  
EXPOSED METAL SHOWN  
SCALE:20X

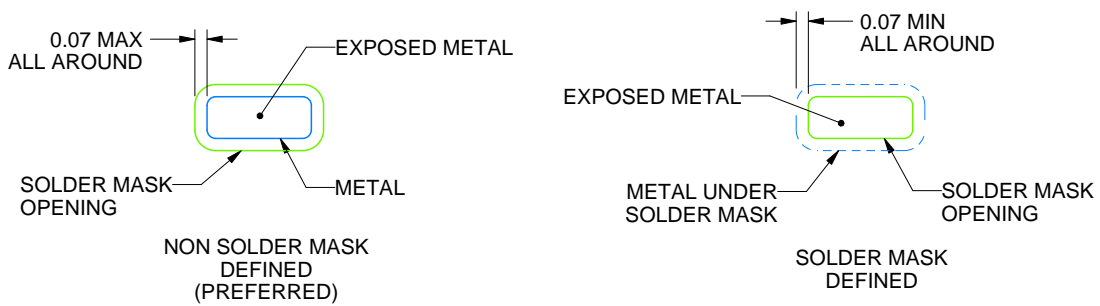

SOLDER MASK DETAILS

4218878/B 07/2018

NOTES: (continued)

4. This package is designed to be soldered to a thermal pad on the board. For more information, see Texas Instruments literature number SLUA271 ([www.ti.com/lit/sluea271](http://www.ti.com/lit/sluea271)).
5. Vias are optional depending on application, refer to device data sheet. If any vias are implemented, refer to their locations shown on this view. It is recommended that vias under paste be filled, plugged or tented.

# EXAMPLE STENCIL DESIGN

DRC0010J

VSON - 1 mm max height

PLASTIC SMALL OUTLINE - NO LEAD

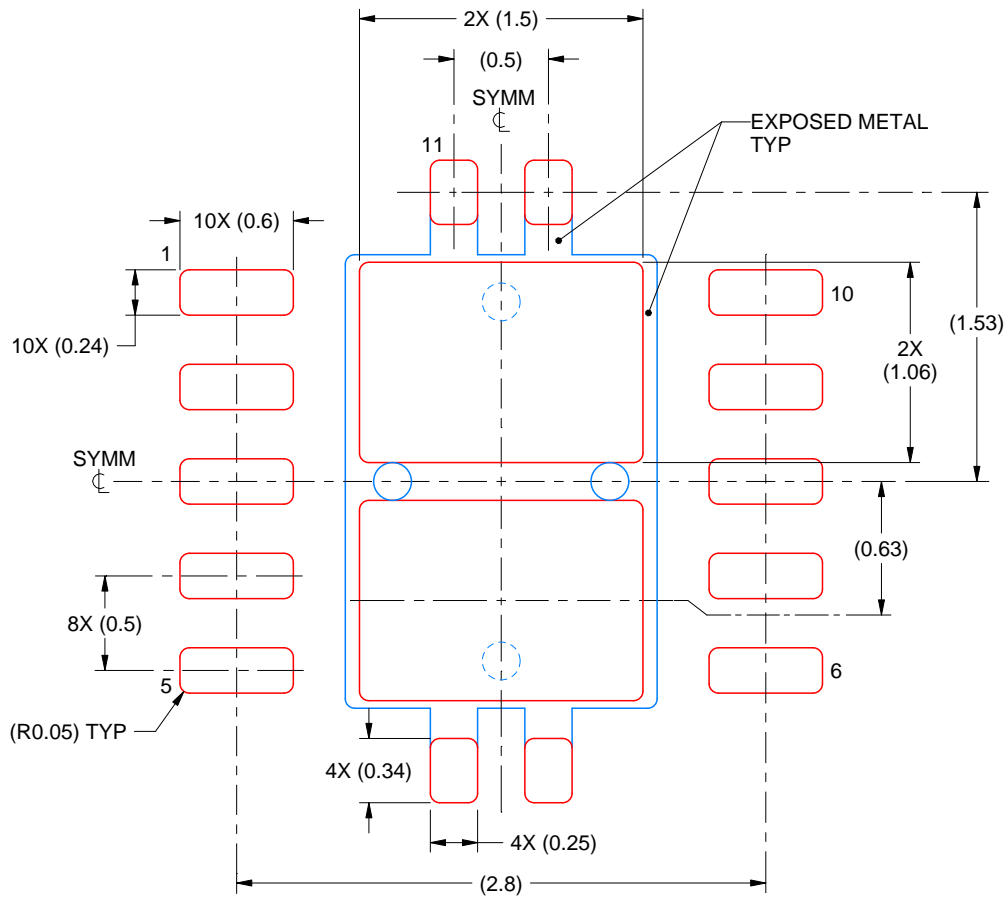

SOLDER PASTE EXAMPLE  
BASED ON 0.125 mm THICK STENCIL

EXPOSED PAD 11:  
80% PRINTED SOLDER COVERAGE BY AREA  
SCALE:25X

4218878/B 07/2018

NOTES: (continued)

6. Laser cutting apertures with trapezoidal walls and rounded corners may offer better paste release. IPC-7525 may have alternate design recommendations.

## 重要声明和免责声明

TI“按原样”提供技术和可靠性数据（包括数据表）、设计资源（包括参考设计）、应用或其他设计建议、网络工具、安全信息和其他资源，不保证没有瑕疵且不做任何明示或暗示的担保，包括但不限于对适销性、某特定用途方面的适用性或不侵犯任何第三方知识产权的暗示担保。

这些资源可供使用 TI 产品进行设计的熟练开发人员使用。您将自行承担以下全部责任：(1) 针对您的应用选择合适的 TI 产品，(2) 设计、验证并测试您的应用，(3) 确保您的应用满足相应标准以及任何其他功能安全、信息安全、监管或其他要求。

这些资源如有变更，恕不另行通知。TI 授权您仅可将这些资源用于研发本资源所述的 TI 产品的应用。严禁对这些资源进行其他复制或展示。您无权使用任何其他 TI 知识产权或任何第三方知识产权。您应全额赔偿因在这些资源的使用中对 TI 及其代表造成的任何索赔、损害、成本、损失和债务，TI 对此概不负责。

TI 提供的产品受 [TI 的销售条款](#) 或 [ti.com](#) 上其他适用条款/TI 产品随附的其他适用条款的约束。TI 提供这些资源并不会扩展或以其他方式更改 TI 针对 TI 产品发布的适用的担保或担保免责声明。

TI 反对并拒绝您可能提出的任何其他或不同的条款。

邮寄地址：Texas Instruments, Post Office Box 655303, Dallas, Texas 75265

Copyright © 2022，德州仪器 (TI) 公司