

DRV3205-Q1 集成三个分流放大器和增强型保护、诊断和监视功能的三相汽车栅极驱动器

1 特性

- 符合汽车类应用的 AEC-Q100 标准：
 - 器件温度 1 级：-40°C 至 +125°C 的环境运行温度范围
- 适用于电机控制的三相桥驱动器
- 适用于 12V 和 24V 应用
- 集成三个高精度电流感测放大器
- 集成升压转换器，栅极驱动到 4.75V
- 驱动 6 个独立的 N 沟道功率金属氧化物半导体场效应晶体管 (MOSFET)
- 针对大电流 FET 提供强力的 1A 栅极驱动
- 可编程死区时间
- 脉宽调制 (PWM) 频率最高达 20kHz
- 支持 100% 占空比运行
- 短路保护功能
 - VDS 监视 (可调检测电平)
 - 分流限制 (可调检测电平)
- 过压和欠压保护
- 过热警告和关断
- 通过 SPI 进行复杂的故障检测和处理
- 系统监控
 - Q&A 看门狗
 - I/O 电源监视
 - ADREF 监视
- 可编程内部故障诊断
- 休眠模式功能
- 耐热增强型 48 引脚薄型四方扁平 (HTQFP) PowerPAD™IC 封装 (7mm x 7mm 尺寸)

2 应用

- 汽车电机控制 应用
 - 电动助力转向系统 (EPS, 电动液压助力转向 (EHPS))
 - 全电刹车和刹车辅助
 - 变速箱
 - 泵
- 工业电机控制 应用

3 说明

DRV3205-Q1 桥式驱动器专用于汽车三相无刷直流电机控制应用。该器件为标准电平 N 沟道 MOSFET 晶体管提供六个专用驱动器。集成 FET 的升压转换器可提供过驱电压，即使在低至 4.75V 的电池电压下也能够实现对功率级的完全控制。这种驱动器强度适用于大电流应用，并且可通过编程来限制峰值输出电流。

该器件整合了稳健的 FET 保护和系统监视功能，例如 Q&A 看门狗以及用于 I/O 电源和 ADC 基准电压的电压监视器。集成的内部诊断功能可通过 SPI 接口进行访问和编程。

器件信息⁽¹⁾

器件型号	封装	封装尺寸 (标称值)
DRV3205-Q1	HTQFP (48)	7.00mm x 7.00mm

(1) 如需了解所有可用封装，请参阅数据表末尾的可订购产品附录。

典型应用图

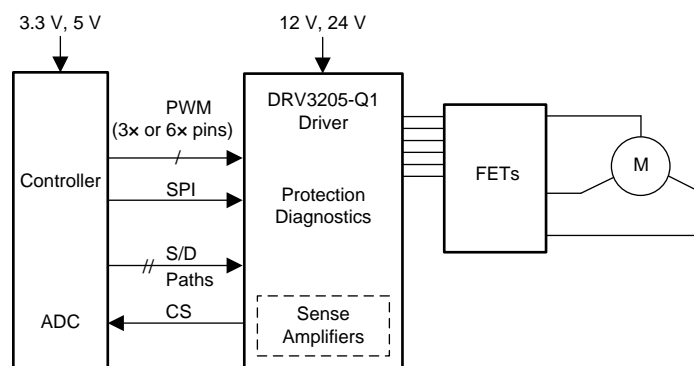

Copyright © 2016, Texas Instruments Incorporated



目录

1 特性	1	7.4 Register Maps	20
2 应用	1	8 Application and Implementation	22
3 说明	1	8.1 Application Information	22
4 修订历史记录	2	8.2 Typical Application	22
5 Pin Configuration and Functions	4	8.3 System Example	22
6 Specifications	6	9 Power Supply Recommendations	24
6.1 Absolute Maximum Ratings	6	10 Layout	24
6.2 ESD Ratings	7	10.1 Layout Guidelines	24
6.3 Recommended Operating Conditions	7	10.2 Layout Example	24
6.4 Thermal Information	8	11 器件和文档支持	25
6.5 Electrical Characteristics	8	11.1 文档支持	25
6.6 Serial Peripheral Interface Timing Requirements ...	14	11.2 接收文档更新通知	25
6.7 Typical Characteristics	15	11.3 社区资源	25
7 Detailed Description	16	11.4 商标	25
7.1 Overview	16	11.5 静电放电警告	25
7.2 Functional Block Diagram	16	11.6 Glossary	25
7.3 Programming	17	12 机械、封装和可订购信息	25

4 修订历史记录

注：之前版本的页码可能与当前版本有所不同。

Changes from Revision D (November 2016) to Revision E	Page
• Added the propagation delay graphs to the <i>Typical Characteristics</i> section	15
• Changed the note on the <i>Single 8-Bit SPI Frame/Transfer</i> figure	17
• Updated the <i>Typical Application Diagram</i> figure	22

Changes from Revision C (October 2016) to Revision D	Page
• Changed the maximum value for the RVSET resistor error detection parameter (4.4.31) from 1.5 to 1.4 kΩ in the <i>Electrical Characteristics</i> table	10
• Changed the units and symbol for the RVSET output voltage parameter (4.4.32–4.4.34), and fixed duplicate position number for $T_J = 25^\circ\text{C}$ and 125°C in the <i>Electrical Characteristics</i> table	10
• Added characterization note to parameters 5.7 and 5.29 through 5.30e in the <i>Electrical Characteristics</i> table	11
• Deleted the VS voltage range test condition from the boost output voltage parameter (6.1) in the <i>Electrical Characteristics</i> table	12
• Added new test condition to the switching frequency parameter (6.3) and add new values for switching frequency at $V_S < 6$ (6.31) in the <i>Electrical Characteristics</i> table	12
• Changed the maximum value for the input pulldown resistor at EN pin parameter (7.4) from 300 to 360 kΩ in the <i>Electrical Characteristics</i> table	12
• Changed the position number for the output high and low voltage 2 parameters in the <i>Electrical Characteristics</i> table ...	12
• Added characterization note to parameters 13.2 through 13.11 in the <i>Serial Peripheral Interface Timing Requirements</i> table	14

Changes from Revision B (October 2016) to Revision C	Page
• Clarified the temperature for the BOOST pin quiescent current parameters (3.6B and 3.6C) and added new temperature condition (3.62B and 3.61C) in the <i>Recommended Operating Conditions</i> table	7
• Deleted the maximum value for the input hysteresis parameters (7.3 and 7.3A) in the <i>Electrical Characteristics</i> table	12
• Changed the values for the input pullup resistance parameter (7.5) in the <i>Electrical Characteristics</i> table	12

Changes from Revision A (October 2016) to Revision B	Page
• 已更改 已将特性部分的 AEC-Q1100 改为 AEC-Q100.....	1
• Changed the maximum value for the VCC5 and VCC3 short-to-ground current from 70 to 80 mA in the <i>Absolute Maximum Ratings</i> table	6
• Changed the minimum value for the high-side/low-side driver shutdown current parameter from 7 to 2 mA in the <i>Electrical Characteristics</i> table	11

Changes from Original (September 2016) to Revision A	Page
• 已更改 器件状态，从产品预览改为量产数据	1

5 Pin Configuration and Functions

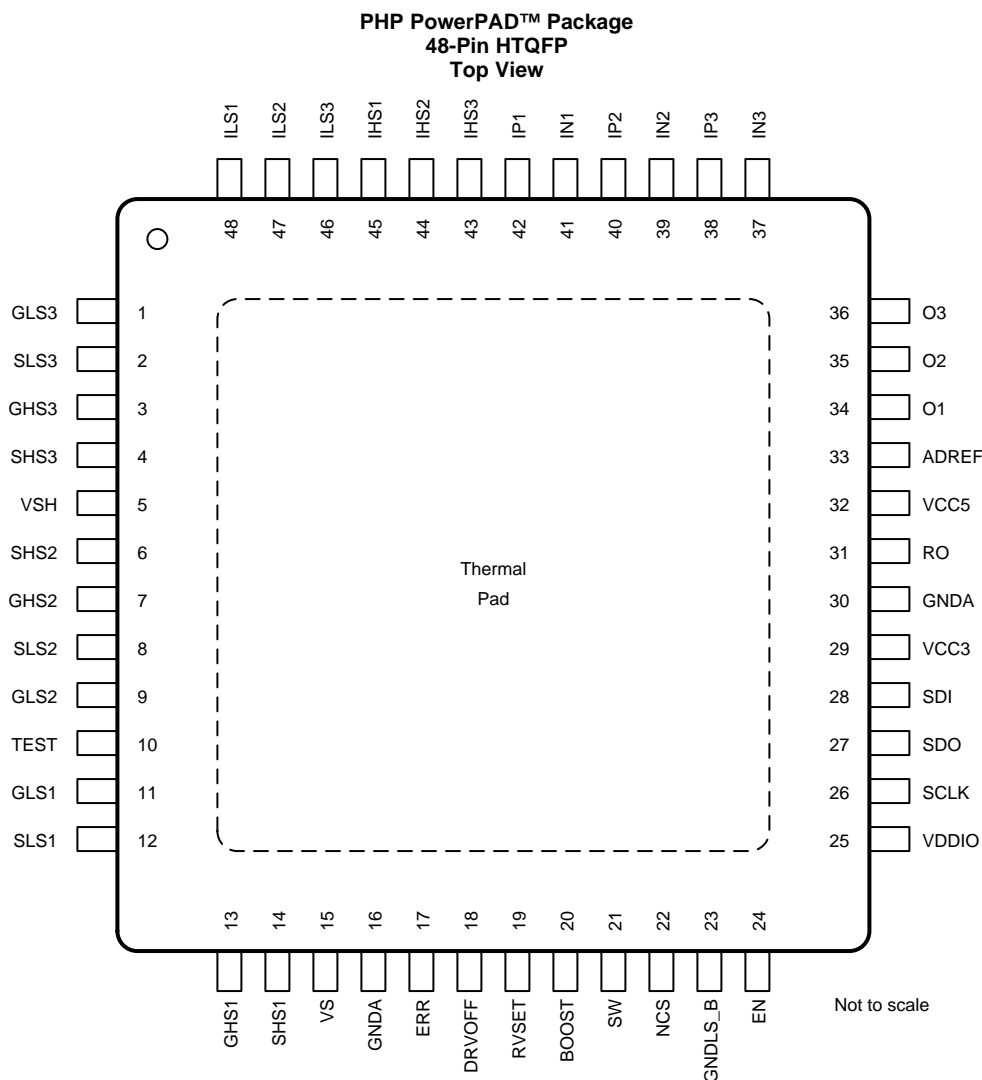

Pin Functions

PIN		TYPE ⁽¹⁾	DESCRIPTION
NO.	NAME		
1	GLS3	PWR	Gate low-side 3, connected to gate of external power MOSFET.
2	SLS3	PWR	Source low-side 3, connected to external power MOSFET for gate discharge and VDS monitoring.
3	GHS3	PWR	Gate high-side 3, connected to gate of external power MOSFET.
4	SHS3	PWR	Source high-side 3, connected to external power MOSFET for gate discharge and VDS monitoring.
5	VSH	HVI_A	Sense high-side, sensing VS connection of the external power MOSFETs for VDS monitoring.
6	SHS2	PWR	Source high-side 2, connected to external power MOSFET gate discharge and VDS monitoring.
7	GHS2	PWR	Gate high-side 2, connected to gate of external power MOSFET.
8	SLS2	PWR	Source low-side 2, connected to external power MOSFET for gate discharge and VDS monitoring.
9	GLS2	PWR	Gate low-side 2, connected to gate of external power MOSFET.
10	TEST	HVI_A	Test mode input, during normal application connected to ground.

(1) Description of pin type: GND = Ground; HVI_A = High-voltage input analog; HVI_D = High-voltage input digital; LVI_A = Low-voltage input analog; LVO_A = Low-voltage output analog; LVO_D = Low-voltage output digital; NC = No connect; PWR = Power output; Supply = Supply input

Pin Functions (continued)

PIN		TYPE ⁽¹⁾	DESCRIPTION
NO.	NAME		
11	GLS1	PWR	Gate low-side 1, connected to gate of external power MOSFET.
12	SLS1	PWR	Source low-side 1, connected to external power MOSFET for gate discharge and VDS monitoring.
13	GHS1	PWR	Gate high-side 1, connected to gate of external power MOS transistor.
14	SHS1	PWR	Source high-side 1, connected to external power MOS transistor for gate discharge and VDS.
15	VS	Supply	Power-supply voltage (externally protected against reverse battery connection).
16	GND_A	GND	Analog ground.
17	ERR	LVO_D	Error (low active), Error pin to indicate detected error.
18	DRVOFF	HVI_D	Driver OFF (high active), secondary bridge driver disable.
19	RVSET	HVI_A	VDDIO / ADREF OV/UV configuration resistor.
20	BOOST	Supply	Boost output voltage, used as supply for the gate drivers.
21	SW	PWR	Boost converter switching node connected to external coil and external diode.
22	NCS	HVI_D	SPI chip select.
23	GNDLS_B	GND	Boost GND to set current limit. Boost switching current goes through this pin through external resistor to ground.
24	EN	HVI_D	Enable (high active) of the device.
25	VDDIO	Supply	I/O supply voltage, defines the interface voltage of digital I/O, for example, SPI.
26	SCLK	HVI_D	SPI clock.
27	SDO	LVO_D	SPI data output.
28	SDI	HVI_D	SPI data input.
29	VCC3	LVO_A	VCC3 regulator, for internal use only. TI recommends an external decoupling capacitor of 0.1 μ F. External load < 100 μ A.
30	GND_A	GND	Analog ground.
31	RO	LVO_A	Analog output.
32	VCC5	LVO_A	VCC5 regulator, for internal use only. Recommended external decoupling capacitor 1 μ F. External load < 100 μ A.
33	ADREF	LVI_A	ADC reference of MCU, used as maximum voltage clamp for O1 to O3.
34	O1	LVO_A	Output current sense amplifier 1.
35	O2	LVO_A	Output current sense amplifier 2.
36	O3	LVO_A	Output current sense amplifier 3.
37	IN3	LVI_A	Current sense negative input 3.
38	IP3	LVI_A	Current sense positive input 3.
39	IN2	LVI_A	Current sense input N 2.
40	IP2	LVI_A	Current sense input P 2.
41	IN1	LVI_A	Current sense input N 1.
42	IP1	LVI_A	Current sense input P 1.
43	IHS3	HVI_D	High-side input 3, digital input to drive the HS3.
44	IHS2	HVI_D	Input HS 2, digital input to drive the HS2.
45	IHS1	HVI_D	Input HS 1, digital input to drive the HS1.
46	ILS3	HVI_D	Low-side input 3, digital input to drive the LS3.
47	ILS2	HVI_D	Input LS 2, digital input to drive the LS2.
48	ILS1	HVI_D	Input LS 1, digital input to drive the LS1.

6 Specifications

6.1 Absolute Maximum Ratings

 over operating free-air temperature range (unless otherwise noted)⁽¹⁾⁽²⁾

POS			MIN	MAX	UNIT
2.1	VS, VSH	DC voltage	-0.3	60	V
2.1a	VS	DC voltage	Negative voltages with minimum serial resistor 5 Ω, T _A = 25°C		V
2.1b	VSH	DC voltage	Negative voltages with minimum serial resistor 10 Ω, T _A = 25°C		V
2.1c	VS	DC voltage	Negative voltages with minimum serial resistor 5 Ω, T _A = 105°C		V
2.1d	VSH	DC voltage	Negative voltages with minimum serial resistor 10 Ω, T _A = 105°C		V
2.2A	GHSx	Gate high-side voltage	-9	70	V
2.2B	SHSx	Source high-side voltage	-9	70	V
2.3	GHSx-SHSx	Gate-source high-side voltage difference	Externally driven, internal limited, see position 5.4 in Electrical Characteristics		V
2.4	GLSx	Gate low-side voltage	-9	20	V
2.5	SLSx	Source low-side voltage	-9	7	V
2.6	GLSx-SLSx	Gate-source low-side voltage difference	Externally driven, internal limited, see position 5.5 in Electrical Characteristics		V
2.7	BOOST, SW	Boost converter	-0.3	70	V
2.8	INx, IPx	Current sense input voltage	-9	7	V
2.8A	INx, IPx	Current sense input current	Clamping current		mA
2.8C	Ox	Current sense output voltage	-0.3	ADREF +0.3	V
2.8D	Ox	Forced input current	-10	10	mA
2.9	VDDIO	Analog input voltage	-0.3	60	V
2.9a	ADREF	Analog input voltage	-0.3	60	V
2.10	ILSx, IHSx, EN, DRVOFF, SCLK, NCS, SDI	Digital input voltage	-0.3	60	V
2.11	RVSET	Analog input voltage	-0.3	60	V
2.13	GND _A , GND _{LS_B}	Difference between GND _A and GND _{LS_B}	-0.3	0.3	V
2.20		Maximum slew rate of SHSx pins, SR _{SHS}	-250	250	V/μs
2.21	ERR, SDO, RO	Analog and digital output voltages	-0.3	6	V
2.21 A	ERR, SDO, RO	Forced input/output current	-10	10	mA
2.22	TEST	Unused pins. Connect to GND.	-0.3	0.3	V
2.24	VCC5	Internal supply voltage	-0.3	6	V
2.24 A		Short-to-ground current, I _{VCC5} ⁽³⁾	Internal current limit		mA
2.25	VCC3	Internal supply voltage	-0.3	3.6	V
2.26		Short-to-ground current, I _{VCC3}	Limited by VCC5		mA
2.27		Driver FET total gate charge (per FET), Q _{gmax}	VS = 12 V, f _{PWM} = 20 kHz, 6 FETs ON/OFF per PWM cycle		200 ⁽⁴⁾ nC
2.28			VS = 24 V, f _{PWM} = 20 kHz, 6 FETs ON/OFF per PWM cycle		100 ⁽⁴⁾ nC

(1) Stresses beyond those listed under *Absolute Maximum Ratings* may cause permanent damage to the device. These are stress ratings only, which do not imply functional operation of the device at these or any other conditions beyond those indicated under *Recommended Operating Conditions*. Exposure to absolute-maximum-rated conditions for extended periods may affect device reliability.

(2) All voltages are with respect to network ground terminal, unless specified otherwise.

(3) I_{VCC5} is not specifying VCC5 output current capability for external load. The allowed external load on VCC5 is specified at position 3.18 in [Recommended Operating Conditions](#).

(4) The maximum value also depends on PCB thermal design, modulation scheme, and motor operation time.

Absolute Maximum Ratings (continued)

over operating free-air temperature range (unless otherwise noted)⁽¹⁾⁽²⁾

POS		MIN	MAX	UNIT
2.14	Operating virtual junction temperature, T_J	-40	150	°C
2.15	Storage temperature, T_{stg}	-55	165	°C

6.2 ESD Ratings

POS		VALUE	UNIT
2.17	$V_{(ESD)}$ Electrostatic discharge	Human-body model (HBM), per AEC Q100-002 ⁽¹⁾	All pins ±2000
2.18			Pins 4, 6, and 14 ±4000
2.19	$V_{(ESD)}$ Electrostatic discharge	Charged-device model (CDM), per AEC Q100-011	All pins ±500
			Corner pins (1, 12, 13, 24, 25, 36, 37, and 48) ±750

(1) AEC Q100-002 indicates that HBM stressing shall be in accordance with the ANSI/ESDA/JEDEC JS-001 specification.

6.3 Recommended Operating Conditions

POS		MIN	NOM	MAX	UNIT	
3.1	VS	Supply voltage, normal voltage operation	Full device functionality. Operation at VS = 4.75 V only when coming from higher VS. Minimum VS for startup = 4.85 V	4.75	40	V
3.2	VSLO	Supply voltage, logic operation	Logic functional (during battery cranking after coming from full device functionality)	4	40	V
3.3	VDDIO	Supply voltage for digital I/Os		2.97	5.5	V
3.4	D	Duty cycle of bridge drivers		0%	100%	
3.5	f_{PWM}	PWM switching frequency		0	22 ⁽¹⁾	kHz
3.6A	I_{VSn}	VS quiescent current normal operation (boost converter enabled, drivers not switching)	Boost converter enabled, see and for SHSx/SLSx connections. EN_GDBIAS = 1		22	mA
3.61A	I_{VSn}	VS quiescent current normal operation (boost converter enabled, drivers not switching)	Boost converter enabled, see and for SHSx/SLSx connections. EN_GDBIAS = 0		22.3	mA
3.6B	I_{BOOSTn}	BOOST pin quiescent current normal operation (drivers not switching)	4.75 V < VS < 20 V, $T_A = 25^\circ\text{C}$ to 125°C		9	mA
3.62B			4.75 V < VS < 20 V, $T_A = -40^\circ\text{C}$		10	
3.61B	I_{VSn}	VS quiescent additional current normal operation because of RVSET thermal voltage output enabled (boost converter enabled, drivers not switching)	THERMAL_RVSET_EN = 1		0.6	mA
3.6C	I_{BOOSTn}	BOOST pin quiescent current normal operation (drivers not switching)	20 < VS < 40 V, $T_A = 25^\circ\text{C}$ to 125°C		9.5	mA
3.61C			20 < VS < 40 V, $T_A = -40^\circ\text{C}$		10.5	
3.6D	$I_{BOOST,sw}$	BOOST pin additional load current because of switching gate drivers	Excluding FET gate charge current. 20-kHz all gate drivers switching at the same time. EN_GDBIAS = 1		4	mA
3.61D	$I_{BOOST,sw}$	BOOST pin additional load current because of switching gate drivers	Excluding FET gate charge current. 20-kHz all gate drivers switching at the same time. EN_GDBIAS = 0		5.4	mA
3.75	$I_{Vsq,1}$	VS quiescent current shutdown (sleep mode) 1	VS = 14 V, no operation, $T_J < 25^\circ\text{C}$, EN = Low, total leakage current on all supply connected pins		20	µA
3.75a	$I_{Vsq,2}$	VS quiescent current shutdown (sleep mode) 2	VS = 14 V, no operation, $T_J < 85^\circ\text{C}$, EN = Low, total leakage current on all supply connected pins		30	µA
3.8	T_J	Junction temperature		-40	150	°C
3.9	T_A	Operating ambient free-air temperature	With proper thermal connection	-40	125	°C
3.11	V_{INx}, V_{IPx}	Current sense input voltage	$V_{IPx} - V_{INx}$, RO = 2.5 V GAIN = 12	-0.15	0.15	V
3.13	ADREF	Clamping voltage for current sense amplifier outputs O1/2/3		2.97	5.5	V
3.13a		Reserved				V

(1) Maximum PWM allowed also depends on maximum operating temperature, FET gate charge current, VS supply voltage, modulation scheme, and PCB thermal design.

Recommended Operating Conditions (continued)

POS			MIN	NOM	MAX	UNIT
3.13b	Reserved					V
3.14	VCC3	Internal supply voltage	VS > 4 V, external load current < 100 μ A, decoupling capacitor typical 0.1 μ F		3.3	V
3.15	I _{VCC3}	VCC3 output current	Intended for MCU ADC input		100	μ A
3.16	C _{VCC3}	VCC3 decoupling capacitance	0.075	0.1	0.2	μ F
3.17	VCC5	Internal supply voltage	VS > 6 V, external load current < 100 μ A, decoupling capacitor typical 1 μ F		5.45	V
3.18	I _{VCC5}	VCC5 output current	Intended for MCU ADC input		100	μ A
3.19	C _{VCC5}	VCC5 decoupling capacitance	0.5	1	1.5	μ F

6.4 Thermal Information

THERMAL METRIC ⁽¹⁾		DRV3205-Q1	UNIT
		PHP (HTQFP)	
		48 PINS	
R _{θJA}	Junction-to-ambient thermal resistance	25.7	°C/W
R _{θJC(top)}	Junction-to-case (top) thermal resistance	10.3	°C/W
R _{θJB}	Junction-to-board thermal resistance	6	°C/W
ψ _{JT}	Junction-to-top characterization parameter	0.2	°C/W
ψ _{JB}	Junction-to-board characterization parameter	5.9	°C/W
R _{θJC(bot)}	Junction-to-case (bottom) thermal resistance	0.3	°C/W

(1) For more information about traditional and new thermal metrics, see the [Semiconductor and IC Package Thermal Metrics](#) application report (SPRA953).

6.5 Electrical Characteristics

over operating temperature T_J = –40°C to 150°C and recommended operating conditions, VS = 4.75 V to 40 V⁽¹⁾, f_{PWM} < 20 kHz (unless otherwise noted)

POS	PARAMETER	TEST CONDITIONS	MIN	TYP	MAX	UNIT
4.1	CURRENT SENSE AMPLIFIER					
4.2.1	V _{off1a}	Initial input offset of amplifiers	T _J = 25°C, ADREF = 5 V, RO_CFG [4:0] = 5'b11000: ADREF × 25 / 50		±1	mV
4.2.1a			T _J = 25°C, ADREF = 3.3 V, RO_CFG [4:0] = 5'b11000: ADREF × 25 / 50		±1	mV
4.2.2	V _{off1b}	Temperature and aging offset ⁽²⁾	ADREF = 5 V, RO_CFG [4:0] = 5'b11000: ADREF × 25 / 50		±1	mV
4.2.2a			ADREF = 3.3 V, RO_CFG [4:0] = 5'b11000: ADREF × 25 / 50		±1	mV
4.2.3	V _{com1} ⁽³⁾	Input common voltage range		–3	3	V
4.2.4	V _{Oa}	Nominal output voltage level, positive ox swing	Normal voltage operation, VS ≥ 5.75 V; 0.5-mA load current		ADREF – 0.5 + V _{oxm}	V
4.2.4a	V _{Oa}	Nominal output voltage level, negative ox swing	Normal voltage operation, VS ≥ 5.75 V; 0.5-mA load current		0.5	V
4.2.4b	V _{Oa}	Nominal output voltage level 2, positive ox swing	Normal voltage operation, VS ≥ 5.75 V; 10- μ A load current		ADREF – 0.06 + V _{oxm}	V
4.2.4c	V _{Oa}	Nominal output voltage level 2, negative ox swing	Normal voltage operation, VS ≥ 5.75 V; 10- μ A load current		0.09	V
4.2.5	V _{Ob}	Output voltage level during low voltage operation, positive ox swing	Low voltage operation, 4.75 V ≤ VS < 5.75 V; 0.5-mA load current		VS – 1.25; ADREF – 0.5 + V _{oxm}	V
4.2.5a	V _{Ob}	Output voltage level during low voltage operation, negative ox swing	Low voltage operation, 4.75 V ≤ VS < 5.75 V; 0.5-mA load current		0.5	V

(1) Product life time depends on VS voltage, PCB thermal design, modulation scheme, and motor operation time. The product is designed for 12-V and 24-V battery system.

(2) Ensured by characterization.

(3) ADREF / VDDIO overvoltage and undervoltage is set by RVSET.

Electrical Characteristics (continued)

over operating temperature $T_J = -40^{\circ}\text{C}$ to 150°C and recommended operating conditions, $V_S = 4.75\text{ V}$ to $40\text{ V}^{(1)}$, $f_{\text{PWM}} < 20\text{ kHz}$ (unless otherwise noted)

POS	PARAMETER	TEST CONDITIONS	MIN	TYP	MAX	UNIT			
4.2.5b	V_{Ob}	Output voltage level during low voltage operation 2, positive ox swing	Low voltage operation, $4.75\text{ V} \leq V_S < 5.75\text{ V}$; $10\text{-}\mu\text{A}$ load current			$V_S - 0.75$; $\text{ADREF} - 0.06$ $+ V_{\text{oxm}}$	V		
4.2.5c	V_{Ob}	Output voltage level during low voltage operation 2, negative ox swing	Low voltage operation, $4.75\text{ V} \leq V_S < 5.75\text{ V}$; $10\text{-}\mu\text{A}$ load current			0.09	V		
4.2.6	GBP	Gain bandwidth product GBP	$0.5\text{ V} \leq \text{O1}/2/3 \leq 4.5\text{ V}$, capacitor load = 25 pF , specified by design.			5	MHz		
4.2.8	G1	Gain 1	SPI configurable, Normal voltage operation, $V_S \geq 5.75\text{ V}$; 0.5-mA load current			7.896	8	8.096	V/V
4.2.9	G2	Gain 2	SPI configurable, Normal voltage operation, $V_S \geq 5.75\text{ V}$; 0.5-mA load current			11.856	12	12.144	V/V
4.2.10	G3	Gain 3	SPI configurable, Normal voltage operation, $V_S \geq 5.75\text{ V}$; 0.5-mA load current			15.808	16	16.192	V/V
4.2.11	G4	Gain 4	SPI configurable, Normal voltage operation, $V_S \geq 5.75\text{ V}$; 0.5-mA load current			31.616	32	32.384	V/V
4.2.12	$\text{PSRR}_{\text{O123}}$	Power supply rejection ratio at DC	VS to O1/2/3 decoupling capacitor typical $1\text{ }\mu\text{F}$ on VCC5 / $0.1\text{-}\mu\text{F}$ VCC3 at DC Specified by design, capacitor load = 25 pF RO = 2.5 V , ADREF = 5 V , gain = 16, dV_S / dOx dV_{CC5} / dOx			60	80		dB
4.2.12a	$\text{CMRR}_{\text{O123}}$	Common mode rejection ratio at DC	Specified by design, capacitor load = 25 pF RO = 2.5 V , ADREF = 5 V , gain = 1, $V_S = 12\text{ V}$			70	80		dB
4.2.12b	CMG_{O123}	Common mode gain at 500 kHz	Specified by design, capacitor load = 25 pF RO = 2.5 V , ADREF = 5 V , gain = 16					-29	dB
4.2.12c	CMG_{O123}	Common mode gain peak	Specified by design, capacitor load = 25 pF RO = 2.5 V , ADREF = 5 V , gain = 16					-15	dB
4.2.13	linamp	Inx, IPx input bias current	VCM (input common mode voltage) = $\pm 3\text{ V}$, RSHUNT_MODE[1:0] = 11				50	90	μA
4.2.13	linamp2	Inx, IPx input bias current	VCM (input common mode voltage) = $\pm 3\text{ V}$, RSHUNT_MODE[1:0] = 2'b000110				60	90	μA
4.2.14	$T_{\text{settle}_{\text{O123}}}$	Ox settling time to within $\pm 2\%$ of final value	Specified by design, capacitor load = 25 pF , RO = 2.5 V , ADREF = 5 V , gain = 16, $0.5\text{ V} \leq \text{O1}/2/3 \leq 4.5\text{ V}$					0.8	μs
4.2.15	linampd	Inx, IPx Input bias differential current	VCM = $\pm 3\text{ V}$ $I_{\text{IPx-INx}}$, $\text{IPx-INx} = 0\text{ V}$, RSHUNT_MODE[1:0] = 11			-1.2		1.2	μA
4.2.16	Rinam	Inx, IPx Input resistance	VCM = $\pm 3\text{ V}$			9	12	15	$\text{k}\Omega$
4.2.12d	$\text{PSRR}_{\text{O123}}$	Power supply rejection ratio at DC	VS to O1/2/3 decoupling capacitor typical $1\text{ }\mu\text{F}$ on VCC5 / $0.1\text{-}\mu\text{F}$ VCC3 at DC specified by design, capacitor load = 25 pF RO = 1.65 V ADREF = 3.3 V , gain = 16, dV_S / dOx dV_{CC5} / dOx			70	80		dB
4.2.12e	$\text{CMRR}_{\text{O123}}$	Common mode rejection ratio at DC	Specified by design, capacitor load = 25 pF RO = 1.65 V ADREF = 3.3 V , gain = 16 $V_S = 12\text{ V}$			70	80		dB
4.2.12f	CMG_{O123}	Common mode gain at 500 kHz	Specified by design, capacitor load = 25 pF RO = 1.65 V ADREF = 3.3 V , gain = 16					-29	dB
4.2.12g	CMG_{O123}	Common mode gain peak	Specified by design, capacitor load = 25 pF RO = 1.65 V ADREF = 3.3 V , gain = 16					-15	dB

Electrical Characteristics (continued)

 over operating temperature $T_J = -40^{\circ}\text{C}$ to 150°C and recommended operating conditions, $V_S = 4.75\text{ V}$ to $40\text{ V}^{(1)}$, $f_{\text{PWM}} < 20\text{ kHz}$ (unless otherwise noted)

POS	PARAMETER	TEST CONDITIONS	MIN	TYP	MAX	UNIT		
4.3	SHIFT BUFFER							
4.3.2	VRO	Shift output voltage range	ADREF = 5 V		0.1 × ADREF	0.5 × ADREF	V	
4.3.3	VRO _{offset}	Shift voltage offset (with respect to RO)	ADREF = 5 V, RO_CFG [4:0] = 5'b11000: ADREF × 25 / 50, I _{load} = internal load		±1.7		mV	
4.3.3a			RO_CFG [4:0] = 5'b00100: ADREF × 5 / 50-5'b10111: ADREF × 24 / 50		±4		mV	
4.3.3b			ADREF = 3.3 V, RO_CFG [4:0] = 5'b11000: ADREF × 25 / 50, I _{load} = internal load		±1.7		mV	
4.3.4	C _{RO}	RO output load capacitance range			0	150	pF	
4.3.5	I _{RO}	Shift output current capability	ADREF = 5 V, RO_CFG [4:0] = 5'b11000: ADREF × 25 / 50		-5		5	mA
4.3.6			RO_CFG [4:0] = 5'b00100: ADREF × 5 / 50-5'b10111: ADREF × 24 / 50		-1		1	mA
4.3.7	T _{dgadref}	ADREF UV/ OV detection deglitch time			3	5	7	µs
4.3.8	PSRR _{RO}	Power supply rejection ratio at DC	Decoupling capacitor typical 1 µF on VCC5 / 0.1 µF VCC3 at DC. Specified by design, capacitor load = 25 pF RO = 2.5 V ADREF = 5 V, Gain = 16, dVS / dRO dVCC5 / dRO		70	80		dB
4.4.9	t _{dgadref}	ADREF UV/OV detection deglitch time			3	5	7	µs
4.4	ADREF / VDDIO							
4.4.1	V _{oxm}	Tolerance of ADREF voltage clamp	Relative to ADREF 5.75 V ≤ V _S		-0.1	0.03	0.25	V
4.4.2	V _{oxos}	Overshoot of O1/2/3 over ADREF	Ox-ADREF; for <1 µs; specified by design				1.2	V
4.4.3	I _{ADREF}	Bias current for voltage clamping circuit	ADREF = 3.3 V, pin to ground				300	µA
4.4.4	V _{ovadref}	Overvoltage threshold	ADREF: 3.3-V setting by RVSET resistor		3.696	3.795	3.894	V
4.4.4a			ADREF: 5-V setting by RVSET resistor		5.6	5.75	5.9	V
4.4.5	V _{uvadref}	Undervoltage threshold	ADREF: 3.3-V setting by RVSET resistor		2.706	2.805	2.904	V
4.4.5a			ADREF: 5-V setting by RVSET resistor		4.1	4.25	4.4	V
4.4.7	V _{ovvddio}	Overvoltage threshold	VDDIO: 3.3-V setting by RVSET resistor		3.696	3.795	3.894	V
4.4.7a			VDDIO: 5-V setting by RVSET resistor		5.6	5.75	5.9	V
4.4.8	V _{uvvddio}	Undervoltage threshold	VDDIO: 3.3-V setting by RVSET resistor		2.706	2.805	2.904	V
4.4.8a			VDDIO: 5-V setting by RVSET resistor		4.1	4.25	4.4	V
4.4.10	R _{vset33}	VDDIO = 3.3 V / ADREF = 3.3-V mode	STAT6 bit[3:0] = 4'b0001		135	150	165	kΩ
4.4.11	R _{vset53}	VDDIO = 5 V / ADREF = 3.3-V mode	STAT6 bit[3:0] = 4'b0100		46	51	56.5	kΩ
4.4.12	R _{vset35}	VDDIO = 3.3 V / ADREF = 5-V mode	STAT6 bit[3:0] = 4'b1000		13.5	15	16.5	kΩ
4.4.13	R _{vset55}	VDDIO = 5 V / ADREF = 5-V mode	STAT6 bit[3:0] = 4'b0010		4.6	5.1	5.65	kΩ
4.4.30	R _{vsetopen}	RVSET resistor error detection			650			kΩ
4.4.31	R _{vsetshort}	RVSET resistor error detection					1.4	kΩ
4.4.32	V _{rvsetjn40}	RVSET output voltage	-40°C T _J , THERMAL_RVSET_EN = 1		1.67	1.745	1.82	V
4.4.33	V _{rvsetj25}		25°C T _J , THERMAL_RVSET_EN = 1		1.445	1.535	1.625	
4.4.34	V _{rvsetj125}		125°C T _J , THERMAL_RVSET_EN = 1		1.085	1.195	1.305	

Electrical Characteristics (continued)

over operating temperature $T_J = -40^\circ\text{C}$ to 150°C and recommended operating conditions, $V_S = 4.75\text{ V}$ to $40\text{ V}^{(1)}$, $f_{\text{PWM}} < 20\text{ kHz}$ (unless otherwise noted)

POS	PARAMETER		TEST CONDITIONS	MIN	TYP	MAX	UNIT
VCC3 / VCC5 REGULATORS							
4.4.14	VCC3	VCC3 regulator output voltage	$V_S > 4\text{ V}$	3	3.15	3.3	V
4.4.15	VCC3 _{UV}	VCC3 regulator undervoltage threshold	$V_S > 4\text{ V}$	2.7	2.85	3	V
4.4.16	VCC3 _{OV} ⁽³⁾	VCC3 regulator overvoltage threshold	$V_S > 4\text{ V}$	3.3	3.45	3.6	V
4.4.17	VCC5_1	VCC5 regulator output voltage 1	$V_S > 6\text{ V}$	5.15	5.3	5.45	V
4.4.18	VCC5_2	VCC5 regulator output voltage 2	$6\text{ V} > V_S > 4.75\text{ V}$	4.6		5.45	V
4.4.19	VCC5 _{UV}	VCC5 regulator undervoltage threshold	$V_S > 4.75\text{ V}$	4.3		4.6	V
4.4.20	VCC5 _{OV}	VCC5 regulator overvoltage threshold	$V_S > 4.75\text{ V}$	5.45	5.6	5.75	V
5. GATE DRIVER							
5.1	$V_{\text{GS,low}}$	Gate-source voltage low, high-side/low-side driver	Active pulldown, $I_{\text{load}} = -2\text{ mA}$	0		0.2	V
5.2	R_{GSp}	Passive gate-source resistance	$V_{\text{gs}} \leq 200\text{ mV}$	110	220	330	k Ω
5.3	R_{GSsa}	Semi-active gate-source resistance	In sleep mode, $V_{\text{GS}} > 2\text{ V}$		2	4	k Ω
5.3b	I_{GSL01}	Low-side driver pullup/pulldown current	Gate driven low by gate driver, CURR1, 3 = 01, SPI configurable	TYP \times 0.65	0.65	TYP \times 1.35	A
5.3c	I_{GSL00}		Gate driven low by gate driver ⁽³⁾ , CURR1, 3 = 00, SPI configurable	TYP \times 0.1	0.15	TYP \times 1.9	A
5.3d	I_{GSL10}		Gate driven low by gate driver, CURR1, 3 = 11, SPI configurable	TYP \times 0.65	1.1	TYP \times 1.35	A
5.3f	I_{GSH01}	High-side driver pullup/pulldown current	Gate driven low by gate driver, CURR0, 2 = 01, SPI configurable	TYP \times 0.65	0.65	TYP \times 1.35	A
5.3g	I_{GSH00}		Gate driven low by gate driver ⁽³⁾ , CURR0, 2 = 00, SPI configurable	TYP \times 0.1	0.15	TYP \times 1.9	A
5.3h	I_{GSH11}		Gate driven low by gate driver, CURR0, 2 = 11, SPI configurable	TYP \times 0.65	1.1	TYP \times 1.35	A
5.3i	I_{GSHsd}	High-side/low-side driver shutdown current		2	30	70	mA
5.4	$V_{\text{GS,HS,high}}$	High-side output voltage	$I_{\text{load}} = -2\text{ mA}$; $4.75\text{ V} < V_S < 40\text{ V}$	9		13.4	V
5.5	$V_{\text{GS,LS,high}}$	Low-side output voltage	$I_{\text{load}} = -2\text{ mA}$	9		13.4	V
5.27	t_{Don}	Propagation on delay time ⁽²⁾	After ILx/IHx rising edge, $C_{\text{load}} = 10\text{ nF}$, CURR1, 3 = 10, $V_{\text{GS}} = 1\text{ V}$	100	200	350	ns
5.31	A_{dt}	Accuracy of dead time	If not disabled in CFG1	-15%		15%	
5.32	IHSxIk_1	Source leak current, total leakage current of source pins	EN = L, SHSx = 1.5 V, $T_J < 125^\circ\text{C}$	-5		5	μA
5.32a	IHSxIk_2		EN = L, SHSx = 1.5 V, $125^\circ\text{C} < T_J < 150^\circ\text{C}$	-40		40	μA
5.29	t_{Doff}	Propagation off delay time ⁽²⁾	ILx/IHx falling edge to $V_{\text{GS,LS,high}}(V_{\text{GS,HS,high}}) - 1\text{ V}$ $C_{\text{iss}} = 10\text{ nF}$, CURR1,3 = 10,	100	200	350	ns
5.30	t_{Doffdiff}	Propagation off delay time difference ⁽²⁾	LSx to LSy and HSx to HSy $C_{\text{load}} = 10\text{ nF}$, CURR1,3 = 10, $V_{\text{GS,LS,high}}(V_{\text{GS,HS,high}}) - 1\text{ V}$			50	ns
5.30a	$t_{\text{Don_Doff_diff}}$	Difference between propagation on delay time and propagation off delay time ⁽²⁾	For each gate driver in each channel: $C_{\text{load}} = 10\text{ nF}$, CURR1, 3 = 10, $V_{\text{GS}} = 1\text{ V}$ (rising), $V_{\text{GS,LS,high}}(V_{\text{GS,HS,high}}) - 1\text{ V}$ (falling)			150	ns
5.30c	t_{ENoff}	Propagation off (EN) deglitching time ⁽²⁾	After falling edge on EN	2.5	6	12	μs
5.30d	t_{SD}	Time until gate drivers initiate shutdown ⁽²⁾	After falling edge on EN		12	24	μs
5.30e	t_{SDDRv}	Time until gate drivers initiate shutdown ⁽²⁾	After rising edge on DRVOFF			10	μs

Electrical Characteristics (continued)

 over operating temperature $T_J = -40^\circ\text{C}$ to 150°C and recommended operating conditions, $V_S = 4.75\text{ V}$ to $40\text{ V}^{(1)}$, $f_{\text{PWM}} < 20\text{ kHz}$ (unless otherwise noted)

POS	PARAMETER		TEST CONDITIONS	MIN	TYP	MAX	UNIT
6.	BOOST CONVERTER						
6.1	V_{BOOST}	Boost output voltage excluding switching ripple and response delay.	BOOST-VS voltage	14	15	16.5	V
6.1b	V_{BOOSTOV}	Boost output voltage overvoltage with respect GND		64	67.5	70	V
6.2	I_{BOOST}	Output current capability	External load current including external MOSFET gate charge current BOOST – VS > V_{BOOSTUV}	40			mA
6.3	f_{BOOST}	Switching frequency	BOOST – VS > V_{BOOSTUV} ; ensured by characterization ⁽⁴⁾	1.8	2.5	3	MHz
6.31			BOOST – VS > V_{BOOSTUV} ; $V_S < 6\text{ V}$; ensured by characterization ⁽⁴⁾	1.1		3	
6.4	V_{BOOSTUV}	Undervoltage shutdown level	BOOST-VS voltage	7		8	V
6.4a	V_{BOOSTUV2}	Undervoltage condition that device may enter RESET state	BOOST-GND voltage			10	V
6.5	t_{BCSD}	Filter time for undervoltage detection		5		6	μs
6.7	$V_{\text{GNDLS_B,off}}$	Voltage at GNDLS_B pin at which boost FET switches off because of current limit		110	150	200	mV
6.7a	$t_{\text{SW,off}}$	Delay of the GNDLS_B current limit comparator	Specified by design			100	ns
6.8	$I_{\text{SW,fail}}$	Internal second-level current limit	GNDLS_B = 0 V	840		1600	mA
6.9	$R_{\text{dson_BSTfet}}$	R_{dson} resistance boost FET	$V_S \geq 6$ $I_{\text{SW}} = V_{\text{GNDLS_B,off}} / 0.33\ \Omega$	0.25		1.5	Ω
6.9a			$V_S < 6$ $I_{\text{SW}} = V_{\text{GNDLS_B,off}} / 0.33\ \Omega$			2	Ω
7.	DIGITAL INPUTS						
7.1	INL	Input low threshold	All digital inputs NCS, DRVOFF, ILSx, IHSx, SDI			$V_{\text{DDIO}} \times 0.3$	V
7.1a	ENH	EN input high threshold	$V_S > 4\text{ V}$	2.7			V
7.1b	ENL	EN input low threshold	$V_S > 4\text{ V}$			0.7	V
7.2	INH	Input high threshold	All digital inputs NCS, DRVOFF, ILSx, IHSx, SDI			$V_{\text{DDIO}} \times 0.7$	V
7.3	Inhys	Input hysteresis	All digital inputs EN, NCS, DRVOFF, ILSx, IHSx, SDI, $V_{\text{DDIO}} = 5\text{ V}$	0.3	0.4		V
7.3a	Inhys	Input hysteresis	All digital inputs EN, NCS, DRVOFF, ILSx, IHSx, SDI, $V_{\text{DDIO}} = 3.3\text{ V}$	0.2	0.3		V
7.4	$R_{\text{pd,EN}}$	Input pulldown resistor at EN pin	EN	140	200	360	k Ω
7.4a	$t_{\text{deg,ENon}}$	Power-up time after EN pin high from sleep mode to active mode	ERR = L → H			5	ms
7.5	R_{pullup}	Input pullup resistance	NCS, DRVOFF	200	280	400	k Ω
7.6	R_{pulldown}	Input pulldown resistance	ILSx, IHSx, SDI, SCLK Input voltage = 0.1 V	100	140	200	k Ω
7.6a	R_{pulldown}	Input pulldown current	ILSx, IHSx, SDI, SCLK Input voltage = V_{DDIO}	4		50	μA
8.	DIGITAL OUTPUTS						
8.1	OH1	Output high voltage 1	All digital outputs: SDO, $I = \pm 2\text{ mA}$; V_{DDIO} in functional range ⁽⁵⁾			$V_{\text{DDIO}} \times 0.9$	V
8.2	OL1	Output low voltage 1	All digital outputs: SDO, $I = \pm 2\text{ mA}$; V_{DDIO} in functional range			$V_{\text{DDIO}} \times 0.1$	V
8.3	OH2	Output high voltage 2	ERR $I = -0.2\text{ mA}$; V_{DDIO} in functional range			$V_{\text{DDIO}} \times 0.9$	V
8.4	OL2	Output low voltage 2	ERR $I = +0.2\text{ mA}$; V_{DDIO} in functional range			$V_{\text{DDIO}} \times 0.1$	V
9.	VDS / VGS / R_{SHUNT} MONITORING						
9.1	V_{SCTH}	VDS short-circuit threshold range	If not disabled in CFG1	0.1		2	V

 (4) During startup when $\text{BOOST-VS} < V_{\text{BOOSTUV}}$, f_{BOOST} is typically 1.25 MHz.

 (5) All digital outputs have a push-pull output stage between V_{DDIO} and ground.

Electrical Characteristics (continued)

over operating temperature $T_J = -40^{\circ}\text{C}$ to 150°C and recommended operating conditions, $V_S = 4.75\text{ V}$ to $40\text{ V}^{(1)}$, $f_{\text{PWM}} < 20\text{ kHz}$ (unless otherwise noted)

POS	PARAMETER	TEST CONDITIONS	MIN	TYP	MAX	UNIT		
9.2	A_{Vds}	Accuracy of VDS monitoring	0.1-V to 0.5-V threshold setting		-50	50	mV	
			0.6-V to 2-V threshold setting		-10%	10%		
9.3	t_{VDS}	Detection filter time	Only rising edge of VDS comparators are filtered		5	μs		
9.4	$V_{\text{gserr+}_1}$	VGS error detection 1	STAT7, IHSx (ILSx) = H		7	8.5	V	
9.5	$V_{\text{gserr-}}$	VGS error detection	STAT7, IHSx (ILSx) = L			2	V	
9.6	t_{VGS}	Detection filter time	CFG6[5:4]		1.0		μs	
9.6a	t_{VGSm}	Detection mask time	CFG6[2:0]		2.5		μs	
9.7	V_{SHUNT}	R_{SHUNT} shutdown threshold range	SPI configurable		75	540	mV	
9.8	A_{VSHUNT}	Accuracy of R_{SHUNT} shutdown	75-mV to 165-mV setting		-18	18	mV	
			180-mV to 540-mV setting		-10%	10%		
9.9	t_{VSHUNT}	Detection filter time			5	μs		
10.	THERMAL SHUTDOWN							
10.1	T_{msd0}	Thermal recovery	Specified by characterization		130	153	$^{\circ}\text{C}$	
10.2	T_{msd1}	Thermal warning	Specified by characterization		140	165	$^{\circ}\text{C}$	
10.3	T_{msd2}	Thermal global reset	Specified by characterization		170	195	$^{\circ}\text{C}$	
10.4	T_{hmsd}	Thermal shutdownx2 hysteresis	Specified by characterization			40	$^{\circ}\text{C}$	
10.5	t_{tSD1}	Thermal warning filter time	Specified by characterization		40	45	μs	
10.6	t_{tSD2}	Thermal shutdownx2 filter time	Specified by characterization		2.5	6	μs	
12.	VS MONITORING							
12.1	$V_{\text{VS,OVoff0}}$	Overvoltage shutdown level range ⁽⁶⁾	Programmable CFG5 mode1, 12-V/24-V mode		29	38	V	
12.1a	$V_{\text{VS,OVoff1}}$	Overvoltage shutdown level ⁽⁶⁾	29-V threshold setting		27.5	29	30.5	V
12.1b	$V_{\text{VS,OVon1}}$	Recovery level form overvoltage shutdown ⁽⁶⁾	29-V threshold setting		26.5	28	29.5	V
12.1c	$V_{\text{VS,OVoff2}}$	Overvoltage shutdown level ⁽⁶⁾	33-V threshold setting		32	33.5	35	V
12.1d	$V_{\text{VS,OVon2}}$	Recovery level form overvoltage shutdown ⁽⁶⁾	33-V threshold setting		31	32.5	34	V
12.1e	$V_{\text{VS,OVoff3}}$	Overvoltage shutdown level ⁽⁶⁾	38-V threshold setting		36.5	38	39.5	V
12.1f	$V_{\text{VS,OVon3}}$	Recovery level form overvoltage shutdown ⁽⁶⁾	38-V threshold setting		35.5	37	38.5	V
12.2	$V_{\text{VS,UVoff}}$	Undervoltage shutdown level ⁽⁶⁾	VS is falling from higher voltage than 4.75 V		4.5		4.75	V
12.2a	$V_{\text{VS,UVon}}$	Recovery level form undervoltage shutdown ⁽⁶⁾	Minimum VS for device startup		4.6		4.85	V
12.3	$t_{\text{VS,SHD}}$	Filter time for overvoltage/undervoltage shutdown			5		6	μs

(6) Shutdown signifies *pre-driver shutdown*, not VCC3/VCC5 regulator shutdown.

6.6 Serial Peripheral Interface Timing Requirements

POS 13		MIN	NOM	MAX	UNIT
13.1	f_{SPI}			4 ⁽¹⁾	MHz
13.2	t_{SPI}	250			ns
13.3	t_{high}	90			ns
13.4	t_{low}	90			ns
13.5	t_{sucs}	$t_{SPI} / 2$			ns
13.6	t_{d1}			60	ns
13.7	t_{susi}	30			ns
13.8	t_{d2}	0		60	ns
13.9	t_{hcs}	45			ns
13.10	t_{hlcs}	250			ns
13.11	t_{tri}			30	ns

(1) The maximum SPI clock tolerance is ±10%.

(2) Ensured by characterization.

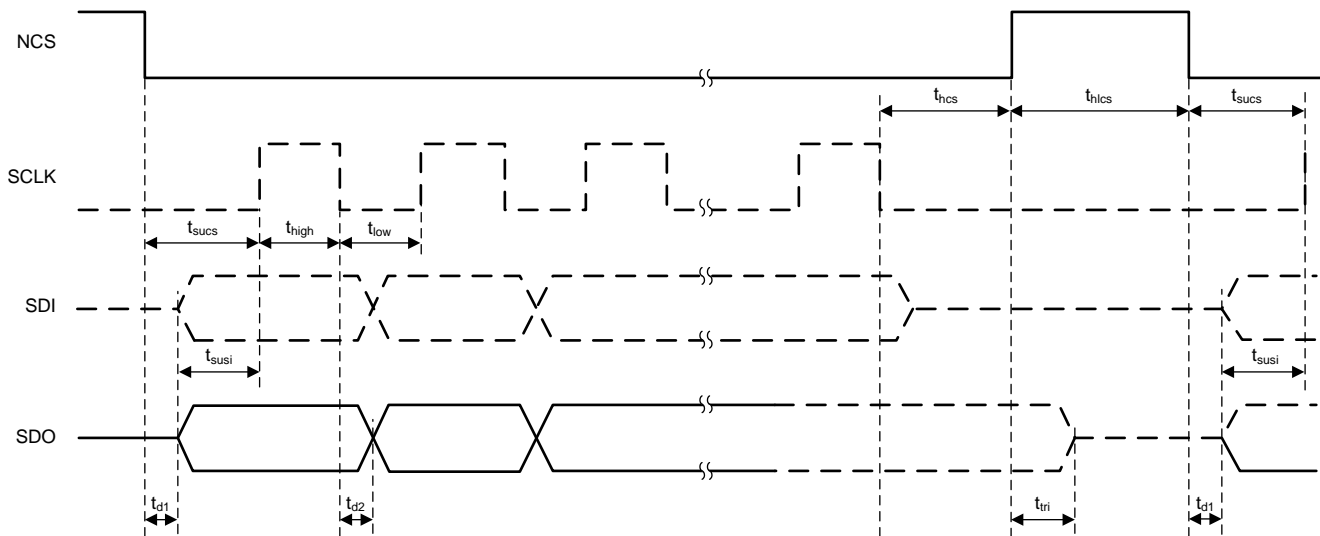

Figure 1. SPI Timing Parameters

6.7 Typical Characteristics

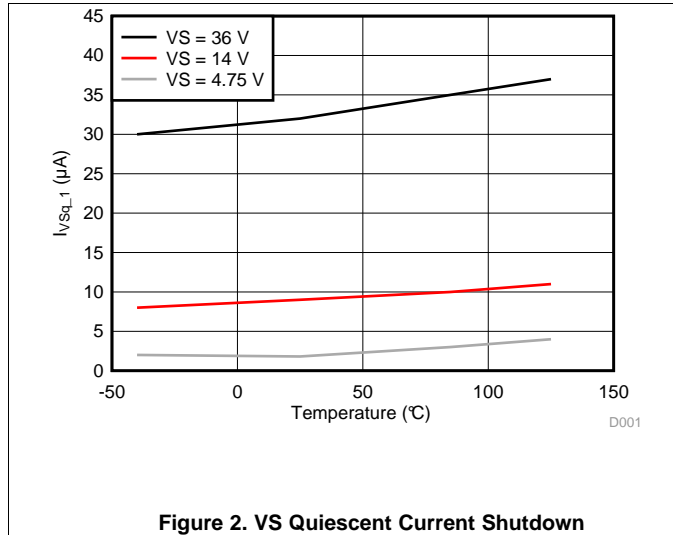

Figure 2. VS Quiescent Current Shutdown

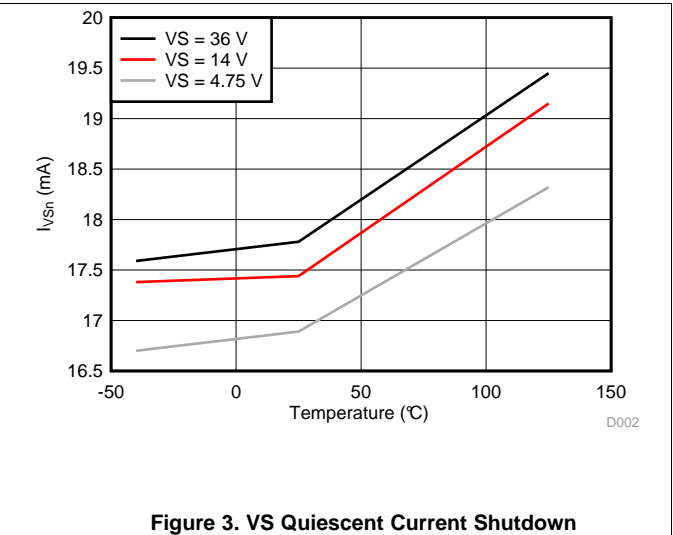

Figure 3. VS Quiescent Current Shutdown

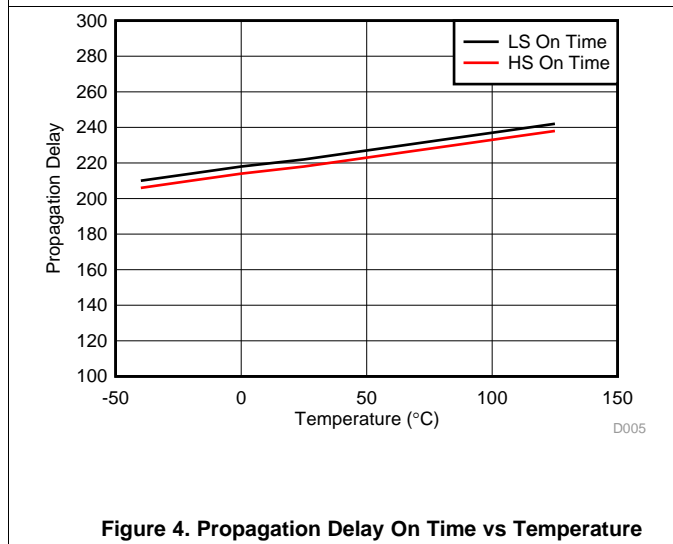

Figure 4. Propagation Delay On Time vs Temperature

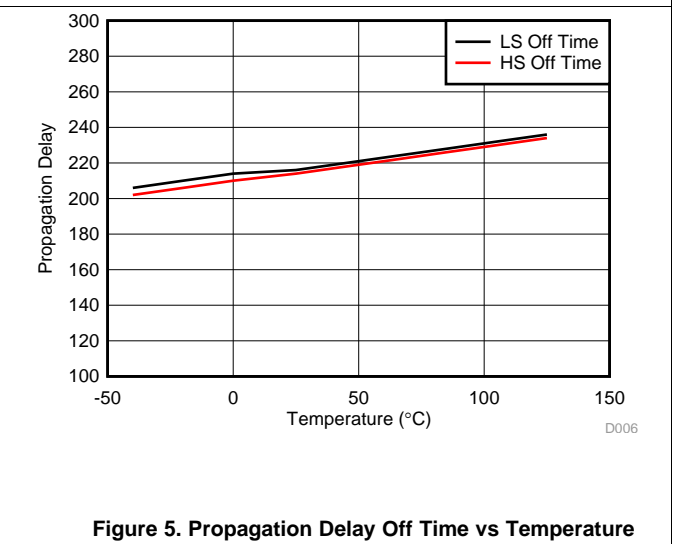

Figure 5. Propagation Delay Off Time vs Temperature

7 Detailed Description

7.1 Overview

The DRV3205-Q1 is designed to control 3-phase brushless DC motors in automotive applications using pulse-width modulation. Three high-side and three low-side gate drivers can be switched individually with low propagation delay. The input logic prevents simultaneous activation of the high-side and low-side driver of the same channel. A configuration and status register can be accessed through a SPI communication interface.

7.2 Functional Block Diagram

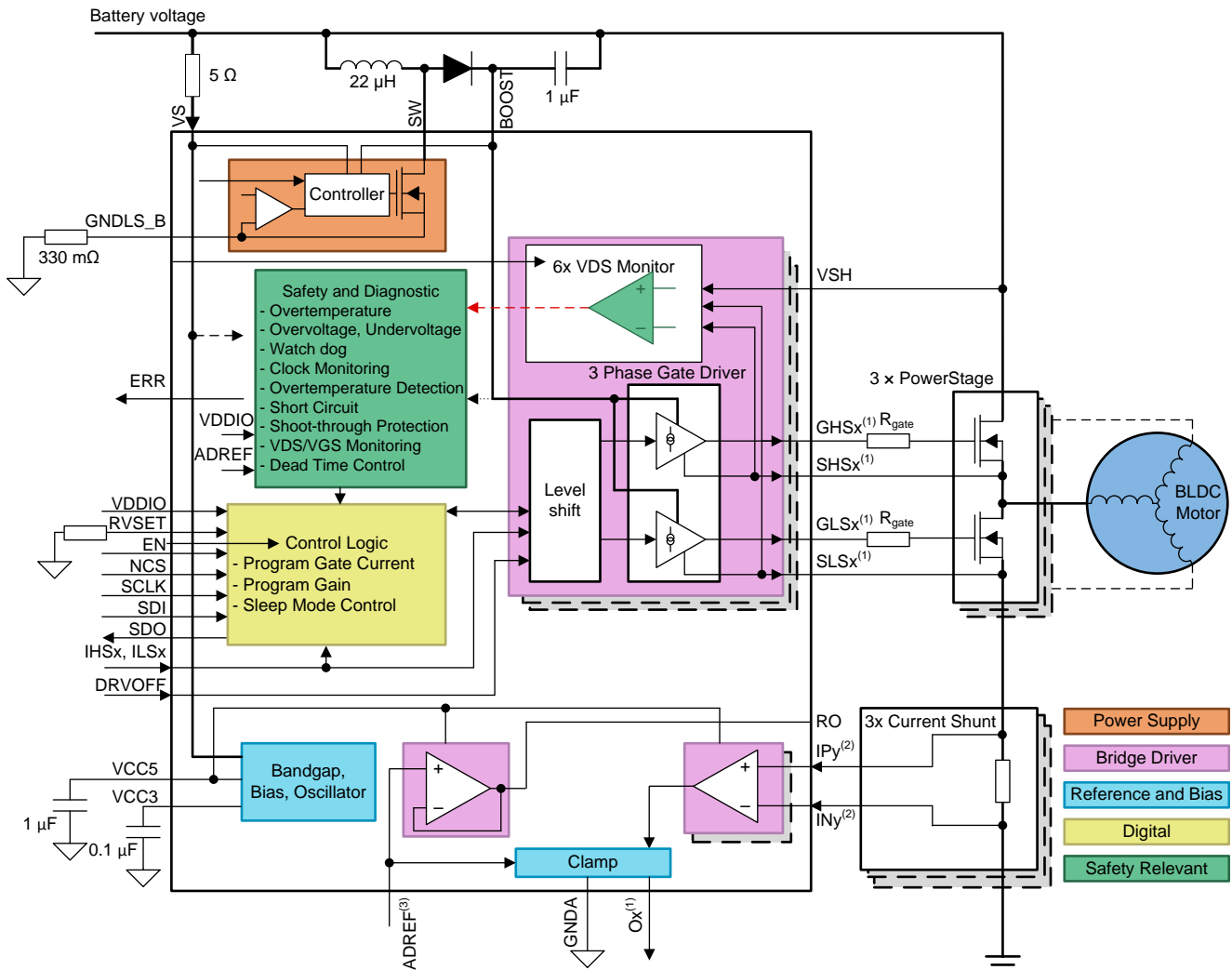

Copyright © 2016, Texas Instruments Incorporated

(1) x = 1, 2, 3

(2) y = 1, 2, 3

(3) An external reference voltage (VCC5 or VCC3) cannot be used for ADRREF voltage.

7.3 Programming

7.3.1 SPI

The SPI slave interface is used for serial communication with the external SPI master (external MCU). The SPI communication starts with the NCS falling edge and ends with NCS rising edge. The NCS high level keeps the SPI slave interface in reset state, and the SDO output in tri-state.

7.3.1.1 Address Mode Transfer

The address mode transfer is an 8-bit protocol. Both SPI slave and SPI master transmit the MSB first.

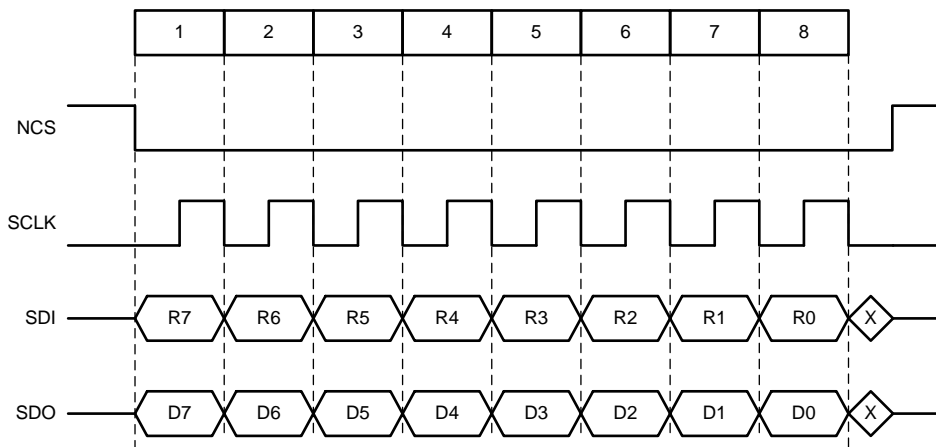

NOTE: SPI master (MCU) and SPI slave (DRV3205-Q1) sample received data on the ~~falling~~ **rising** SCLK edge and transmit on the ~~rising~~ **falling** SCLK edge.

Figure 6. Single 8-Bit SPI Frame/Transfer

After the NCS falling edge, the first word of 7 bits are address bits followed by the RW bit. During first address transfer, the device returns the STAT1 register on SDO.

Each complete 8-bit frame will be processed. If NCS goes high before a multiple of 8 bits is transferred, the bits are ignored.

7.3.1.1.1 SPI Address Transfer Phase

Figure 7. SPI Address Transfer Phase Bits

Bit	D7	D6	D5	D4	D3	D2	D1	D0
Function	ADDR6	ADDR5	ADDR4	ADDR3	ADDR2	ADDR1	ADDR0	RW

ADDR [6:0] Register address

RW Read and write access

RW = 0: Read access. The SPI master performs a read access to selected register. During following SPI transfer, the device returns the requested register read value on SDO, and device interprets SDI bits as a next address transfer.

RW = 1: Write access. The master performs a write access on the selected register. The slave updates the register value during next SPI transfer (if followed immediately) and returns the current register value on SDO.

7.3.1.2 SPI Data Transfer Phase

Figure 8. SPI Data Transfer Phase Bits

Bit	D7	D6	D5	D4	D3	D2	D1	D0
Function	DATA7	DATA6	DATA5	DATA4	ADDR3	DATA2	DATA1	DATA0

DATA [7:0] Data value for write access (8-Bit).

Figure 8 shows data value encoding scheme during a write access. Mixing the two access modes (write and read access) during one SPI communication sequence (NCS = 0) is possible. The SPI communication can be terminated after single 8-bit SPI transfer by asserting NCS = 1. Device returns STAT1 register (for the very first SPI transfer after power-up) or current register value that was addressed during SPI Transfer Address Phase.

7.3.1.3 Device Data Response

Figure 9. Device Data Response Bits

Bit	D7	D6	D5	D4	D3	D2	D1	D0
Function	REG7	REG6	REG5	REG4	REG3	REG2	REG1	REG0

REG [7:0] Internal register value. All unused bits are set to 0.

Figure 10 shows a complete 16-bit SPI frame. Figure 11, Figure 12, Figure 13, Figure 14, Figure 15, and Figure 16 show the frame examples.

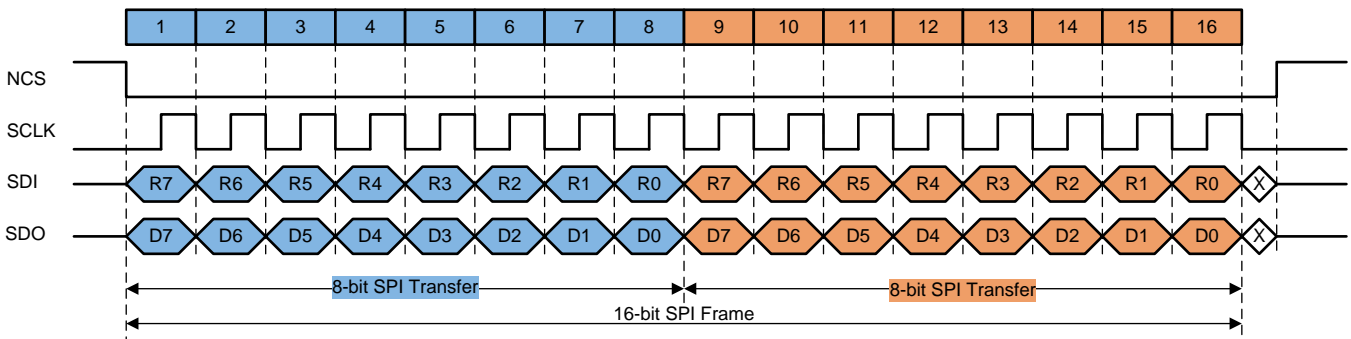

SPI Master (MCU) and SPI slave (DRV3205-Q1) sample received data on the rising SCLK edge, and transmit data on the falling SCLK edge

Figure 10. 16-Bit SPI Frame

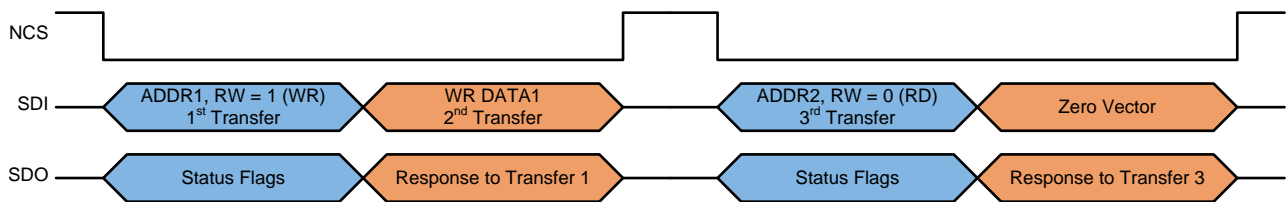

Figure 11. Write Access Followed by Read Access

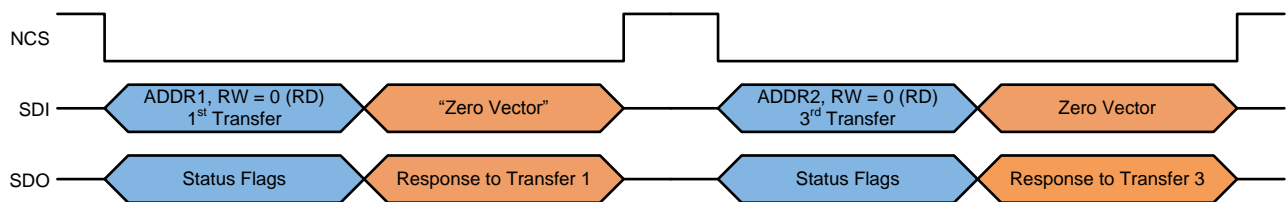

Figure 12. Read Access Followed by Read Access

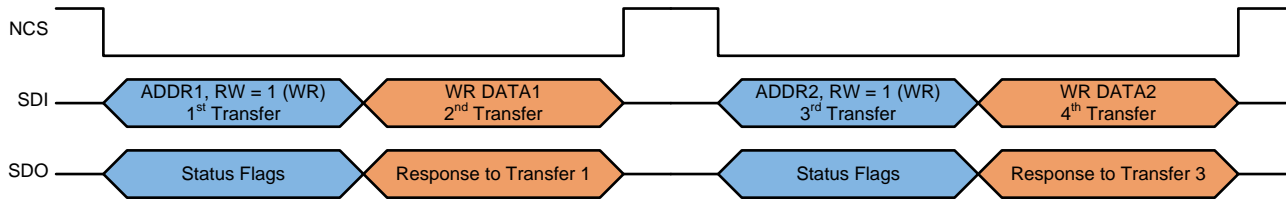

Figure 13. Write Access Followed by Write Access

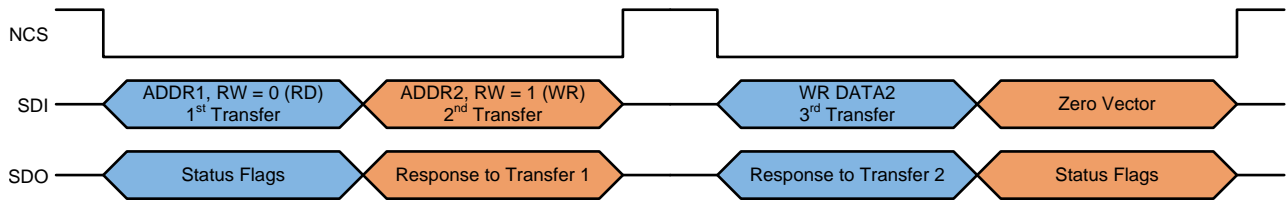

Figure 14. Read Access Followed by Write Access

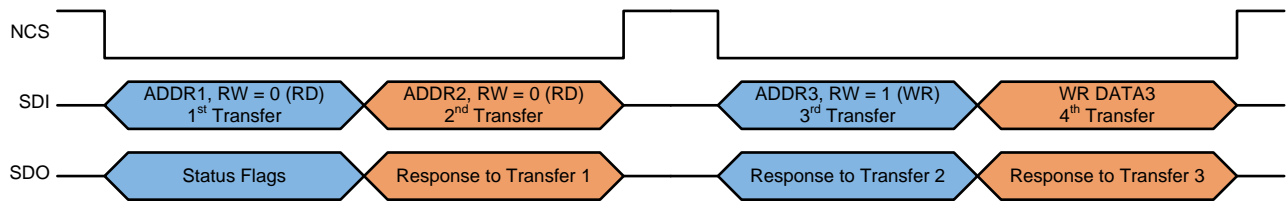

Figure 15. Read Access Followed by Read Access Followed by Write Access

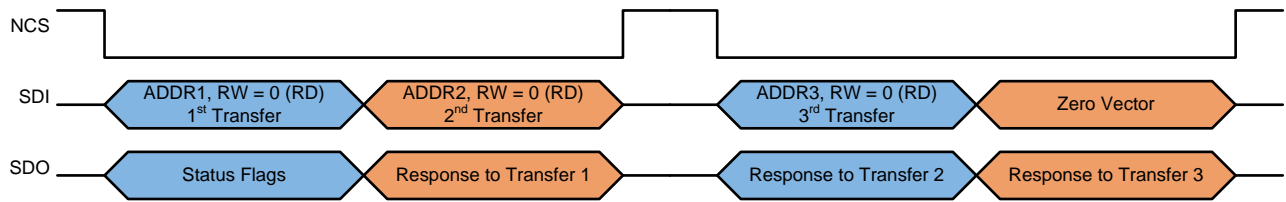

Figure 16. Read Access Followed by Read Access Followed by Read Access

7.4 Register Maps

Table 1. Register Address Map

Address	Name	Reset Value	CRC Check	Access State ⁽¹⁾	Reset Event ⁽²⁾ (bit wide exception)
0x01	Configuration register 0 (CFG0)	8'h3F	Yes	W/R : D, A:[6:3] R : A(7,[2:0], SF	RST1-4
0x02	Configuration register 1 (CFG1)	8'h3F	Yes	W/R: D R: A, SF	RST1-4
0x03	Configuration register 2 (CFG2)	8'h00	Yes	W/R: D R: A, SF	RST1-4
0x04	HS 1/2/3 drive register (CURR0) ON	8'h00	Yes	W/R: D R: A, SF	RST1-4
0x05	LS 1/2/3 drive register (CURR1) ON	8'h00	Yes	W/R: D R: A, SF	RST1-4
0x06	HS 1/2/3 drive register (CURR2) OFF	8'h00	Yes	W/R: D R: A, SF	RST1-4
0x07	LS 1/2/3 drive register (CURR3) OFF	8'h00	Yes	W/R: D R: A, SF	RST1-4
0x08	Safety/error configuration register (SECR1)	8'hC0	Yes	W/R: D R: A, SF	RST1
0x09	Safety function configuration register (SFCR1)	8'h80	Yes	W/R: D R: A, SF	RST1-3
0x0A	Status register 0 (STAT0)	8'h00	No	R: D, A, SF	RST1-4
0x0B	Status register 1 (STAT1)	8'h80	No	R: D, A, SF	RST1-3
0x0C	Status register 2 (STAT2)	8'h00	No	R: D, A, SF	RST1-3
0x0D	Status register 3 (STAT3)	8'h03	No	R: D, A, SF	RST1-3
0x0E	Status register 4 (STAT4)	8'h00	No	R: D, A, SF	RST1-3
0x0F	Status register 5 (STAT5)	8'h03	No	R: D, A, SF	RST1-3 (Bit[4]:RST1)
0x10	Status register 6 (STAT6)	8'h00	No	R: D, A, SF	RST1-3
0x11	Status register 7 (STAT7)	8'h00	No	R: D, A, SF	RST1-4
0x12	Status register 8 (STAT8)	8'h00	No	R: D, A, SF	RST1-4 (Bit[0]:RST1)
0x13	Safety error status (SAFETY_ERR_STAT)	8'h00	No	R: D, A, SF	RST1-3 (Bit[3:1]:RST1)
0x14	Status register 9 (STAT9)	8'h00	No	R: D, A, SF	RST1-3
0x15	Reserved1	8'h00	No	W/R: D, A, SF	RST1-3
0x16	Reserved2	8'h00	No	W/R: D, A, SF	RST1-3
0x1E	SPI transfer write CRC register (SPIWR_CRC)	8'h00	No	W/R: D, A, SF	RST1-3
0x1F	SPI transfer read CRC register (SPIRD_CRC)	8'hFF	No	R: D, A, SF	RST1-3
0x20	SAFETY_CHECK_CTRL register (SFCC1)	8'h01	No	W/R: D R: A, SF	RST1-3
0x21	CRC control register (CRCCTL)	8'h00	No	W/R: D, A R: SF	RST1-3
0x22	CRC calculated (CRCCALC)	N/A	No	W/R: D R: A, SF	RST1-3
0x23	Reserved 3	8'h00	No	W/R: D, A, SF	RST1-3
0x24	HS/LS read back (RB0)	8'h00	No	R: D, A, SF	RST1-3
0x25	HS/LS count control (RB1)	8'h00	No	W/R: D, A R: SF	RST1-4

(1) W/R: Write and Read access possible, W: Write access possible, R: Read access possible

D: DIAGNOSTIC STATE, A: ACTIVE STATE, SF: SAFE STATE, SY: STANDBY STATE, R: RESET

(2) RST1: Power up, RST2: System clock error detected by clock monitor RST3: VCC3 UV/OV or from other state to RESET, RST4: LBI

Register Maps (continued)
Table 1. Register Address Map (continued)

Address	Name	Reset Value	CRC Check	Access State ⁽¹⁾	Reset Event ⁽²⁾ (bit wide exception)
0x26	HS/LS count (RB2)	8'h00	No	R: D, A, SF	RST1-4
0x27	Configuration register 3 (CFG3)	8'hAB	Yes	W/R: D R: A, SF	RST1-4
0x28	Configuration register 4 (CFG4)	8'h00	Yes	W/R: D R: A, SF	RST1-4
0x29	Configuration register 5 (CFG5)	8'hAB	Yes	W/R: D R: A, SF	RST1-3
0x2A	CSM unlock (CSM_UNLOCK1)	8'h00	No	W/R: D R: A, SF	RST1-4
0x2B	CSM unlock (CSM_UNLOCK2)	8'h3F	No	W/R: D R: A, SF	RST1-4
0x2C	RO configuration register 2 (RO_CFG)	8'h00	Yes	W/R: D R: A, SF	RST1-4
0x2D	Safety BIST control register 1 (SAFETY_BIST_CTL1)	8'h00	Yes	W/R: D R: SF, A	RST1-3
0x2E	SPI test register (SPI_TEST)	8'h00	No	W/R: D, A, SF	RST1-4
0x2F	Reserved4	8'h00	No	W/R: D, A, SF	RST1-3
0x30	Safety BIST control register 2 (SAFETY_BIST_CTL2)	8'h00	Yes	W/R: D R: SF, A	RST1-3 (Bit[5]:RST1)
0x31	Watch dog timer configuration register (WDT_WIN1_CFG)	8'h02	Yes	W/R: D R: SF, A	RST1-4
0x32	Watch dog timer configuration register (WDT_WIN2_CFG)	8'h08	Yes	W/R: D R: SF, A	RST1-4
0x33	Watch dog timer TOKEN register (WDT_TOKEN_FDBCK)	8'h04	Yes	W/R: D R: SF, A	RST1
0x34	Watch dog timer TOKEN register (WDT_TOKEN_VALUE)	8'h40	No	R: D, SF, A	RST1-4
0x35	Watch dog timer ANSWER register (WDT_ANSWER)	8'h00	No	W/R: D, A, SF	RST1-4
0x36	Watch dog timer status register (WDT_STATUS)	8'hC0	No	R: D, A, SG	RST1-4
0x37	Watch dog failure detection configuration register (WD_FAIL_CFG)	8'hEC	Yes	W/R: D R: SF, A	RST1-4
0x38	Configuration register 6 (CFG6)	8'h10	Yes	W/R: D R: A, SF	RST1-4
0x39	Configuration register 7 (CFG7)	8'h13	Yes	W/R : D R : A, SF	RST1-4
0x3A	Configuration register 8 (CFG8)	8'h20	Yes	W/R : D R : A, SF	RST1-4
0x3B	Configuration register 9 (CFG9)	8'hFE	Yes	W/R : D R : A, SF	RST1-4

8 Application and Implementation

NOTE

Information in the following applications sections is not part of the TI component specification, and TI does not warrant its accuracy or completeness. TI's customers are responsible for determining suitability of components for their purposes. Customers should validate and test their design implementation to confirm system functionality.

8.1 Application Information

The DRV3205-Q1 is a predriver for automotive applications featuring three-phase brushless DC-motor control. Because this device has a boost regulator for charging high-side gates, it can handle gate charges of 250 nC. A boost converter allows full control on the power-stages even for a low battery voltage down to 4.75 V.

8.2 Typical Application

8.2.1 Three-Phase Motor Drive-Device for Automotive Application

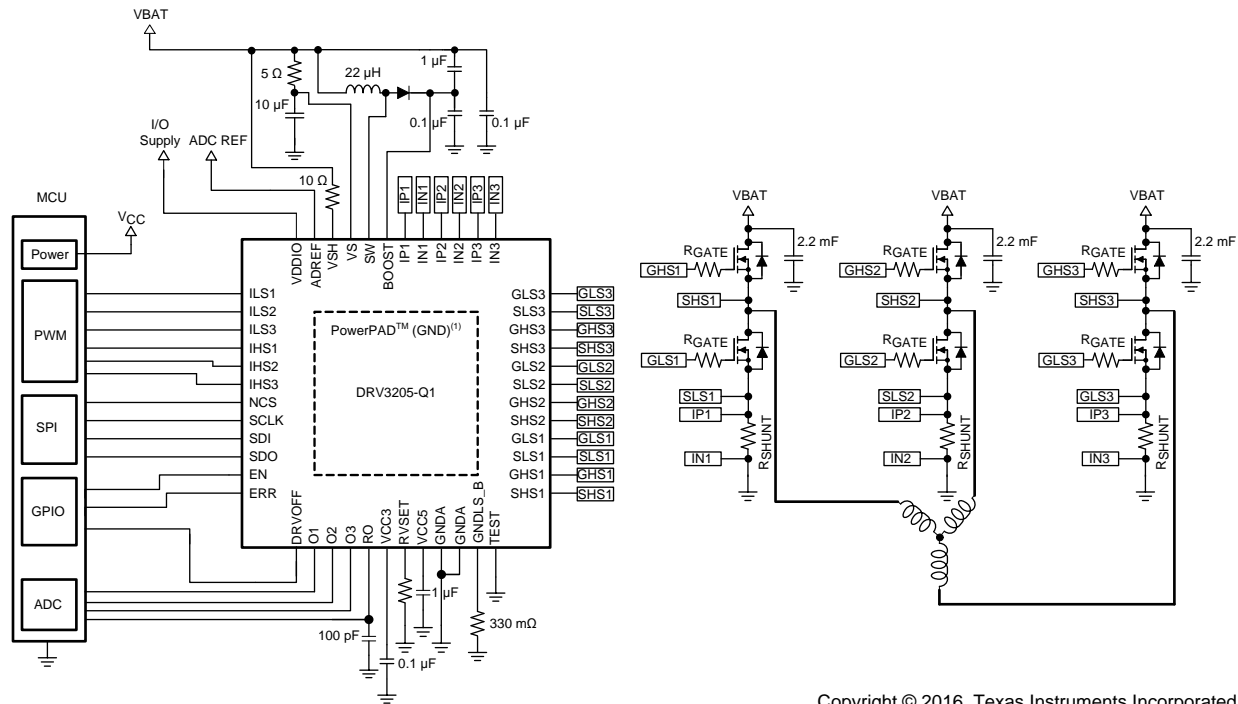

Copyright © 2016, Texas Instruments Incorporated

- (1) This schematic of the DRV3205-Q1 48-pin HTQFP does not provide a true representation of physical pin locations.
- (2) Use same supply from the TPS6538x as the supply used for the MCU IO.
- (3) Resistor not required for reverse protected battery.
- (4) L1 = B82442A1223K000 INDUCTOR, SMT, 22 µH, 10%, 480 mA). The maximum inductor current must be more than $V_{GNDLS_B} / 330\text{ m}\Omega$.
- (5) D1 = SS28 (DIODE, SMT, SCHOTTKY, 80 V, 2 A). A fast recovery diode is recommended.
- (6) QxHS, QxLS = IRFS3004PBF (HEXFET, N-CHANNEL, POWER MOSFET, D2PACK)
- (7) R_{shunt1} and R_{shunt2} = BVR-Z-R0005 (RES, SMT, 4026, PRECISION POWER, 0.0005 Ω, 1%, 5 W)
- (8) R_{gate} = Must be adjust based on system requirement such as EMI, Slew rate, and power

Figure 17. Typical Application Diagram

8.3 System Example

Figure 18 shows a typical system example for an electric power-steering system.

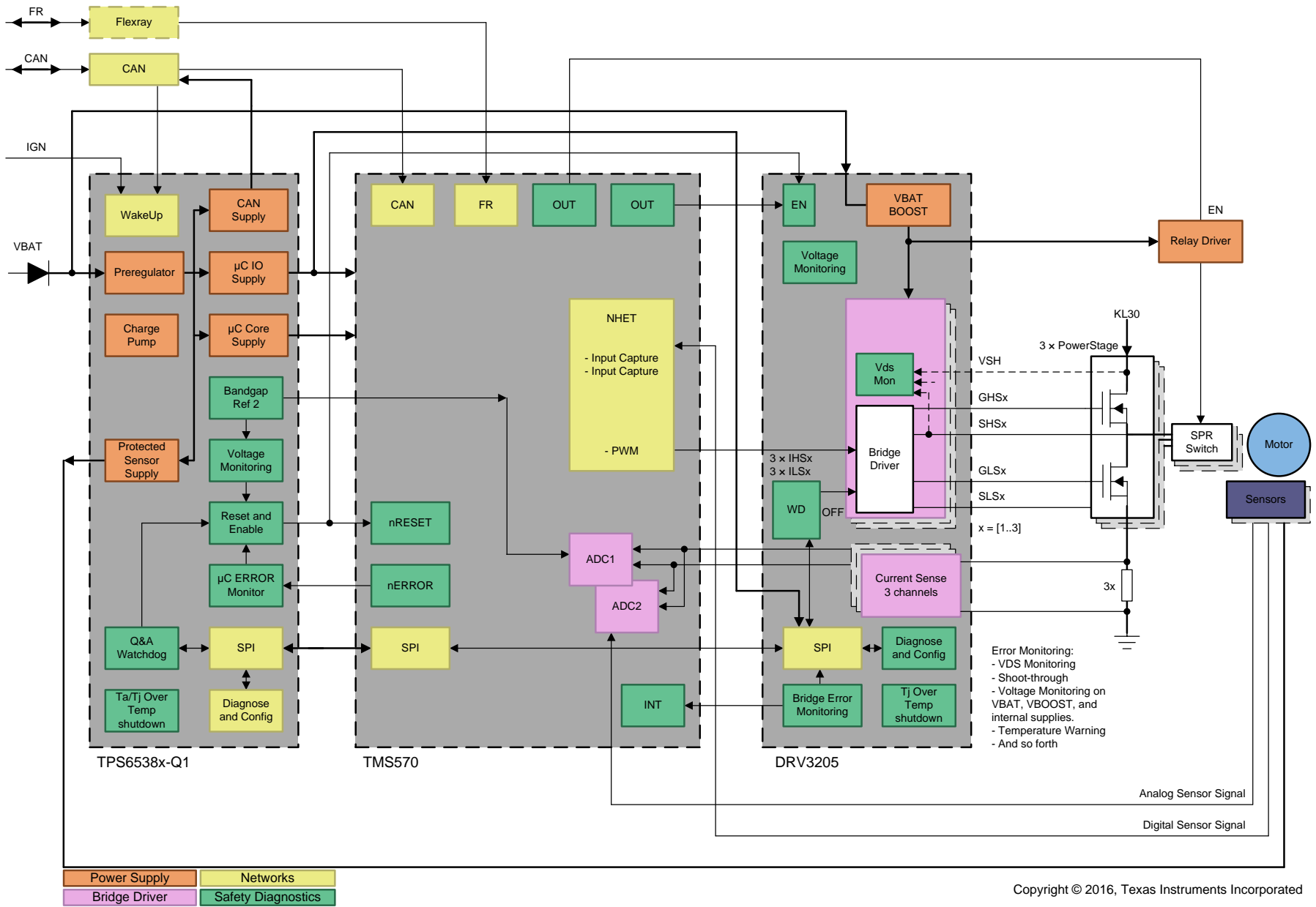

Figure 18. Typical System – Electrical Power Steering Example

9 Power Supply Recommendations

The device is designed to operate from an input voltage supply range of 4.75 V to 40 V. The protection circuit must be placed for protection against reverse supply connection.

10 Layout

10.1 Layout Guidelines

Use the following guidelines when designing a PCB for the DRV3205-Q1:

- In addition to the GND pins, the DRV3205-Q1 makes an electrical connection to GND through the PowerPAD. Always check that the PowerPAD has been properly soldered (see *PowerPAD™ Thermally Enhanced Package* [SLMA002]).
- The VS bypass capacitors should be placed close to the power supply terminals. See the VS box in [Figure 19](#)
- Place the VCC5 and VCC5 bypass capacitors close to the corresponding pins with a low impedance path to the ground plane pin (pin 16). See the VCC3 VCC5 bypass box in [Figure 19](#).
- AGND should all be tied to the ground plane through a low impedance trace or copper fill.
- Add stitching vias to reduce the impedance of the GND path from the top to bottom side.
- Try to clear the space around and below the DRV3205-Q1 to allow for better heat spreading from the PowerPAD.
- Route the sense lines, IPx and INx, each with a unique trace, directly to either side of the sense resistor. See the SENSE box in [Figure 19](#).
- Keep the BOOST components close to the device and current loops small. See the BOOST boxes in [Figure 19](#).
- Place the current sense resistors close to the respective low-side FET. See the SENSE box in [Figure 19](#).
- Place the GNDLS_B resistor close to the device pin. See the GNDLS_B box in [Figure 19](#).

10.2 Layout Example

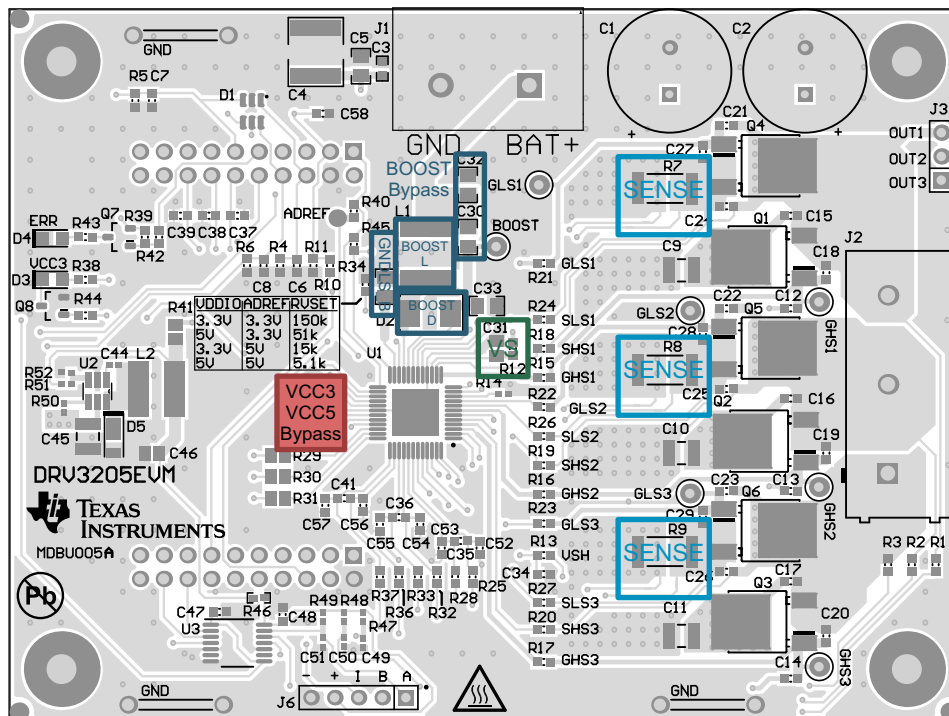

Figure 19. Layout Schematic

11 器件和文档支持

11.1 文档支持

11.1.1 相关文档

相关文档请参阅以下部分：

- 《24V 汽车系统中的 DRV3205-Q1 应用》
- 《DRV3205-Q1 评估模块用户指南》
- 《DRV3205-Q1 源引脚上的负电压应力》
- 《DRV3205-Q1 安全手册》
- 《采用 DRV3205-Q1 的电动助力转向设计指南》
- 《PowerPAD™ 散热增强型封装》
- 《保护汽车电机驱动系统免受反极性情况的影响》
- 《用于 DRV3205-Q1 的看门狗计时器配置问答》
- 《用于安全相关应用中的微控制器的 TPS653850-Q1 多轨电源》
- 《用于安全相关应用中的微控制器的 TPS653853-Q1 多轨电源》

11.2 接收文档更新通知

如需接收文档更新通知，请访问 www.ti.com.cn 网站上的器件产品文件夹。点击右上角的提醒我 (Alert me) 注册后，即可每周定期收到已更改的产品信息。有关更改的详细信息，请查阅已修订文档中包含的修订历史记录。

11.3 社区资源

The following links connect to TI community resources. Linked contents are provided "AS IS" by the respective contributors. They do not constitute TI specifications and do not necessarily reflect TI's views; see TI's [Terms of Use](#).

TI E2E™ Online Community *TI's Engineer-to-Engineer (E2E) Community*. Created to foster collaboration among engineers. At e2e.ti.com, you can ask questions, share knowledge, explore ideas and help solve problems with fellow engineers.

Design Support *TI's Design Support* Quickly find helpful E2E forums along with design support tools and contact information for technical support.

11.4 商标

PowerPAD, E2E are trademarks of Texas Instruments.
All other trademarks are the property of their respective owners.

11.5 静电放电警告



ESD 可能会损坏该集成电路。德州仪器 (TI) 建议通过适当的预防措施处理所有集成电路。如果不遵守正确的处理措施和安装程序，可能会损坏集成电路。

ESD 的损坏小至导致微小的性能降级，大至整个器件故障。精密的集成电路可能更容易受到损坏，这是因为非常细微的参数更改都可能会导致器件与其发布的规格不相符。

11.6 Glossary

SLYZ022 — *TI Glossary*.

This glossary lists and explains terms, acronyms, and definitions.

12 机械、封装和可订购信息

以下页中包括机械、封装和可订购信息。这些信息是针对指定器件可提供的最新数据。这些数据会在无通知且不对本文档进行修订的情况下发生改变。欲获得该数据表的浏览器版本，请查阅左侧的导航栏。

PACKAGING INFORMATION

Orderable Device	Status (1)	Package Type	Package Drawing	Pins	Package Qty	Eco Plan (2)	Lead finish/ Ball material (6)	MSL Peak Temp (3)	Op Temp (°C)	Device Marking (4/5)	Samples
DRV3205QPHPRQ1	ACTIVE	HTQFP	PHP	48	1000	RoHS & Green	NIPDAU	Level-3-260C-168 HR	-40 to 125	DRV32205Q	Samples

(1) The marketing status values are defined as follows:

ACTIVE: Product device recommended for new designs.

LIFEBUY: TI has announced that the device will be discontinued, and a lifetime-buy period is in effect.

NRND: Not recommended for new designs. Device is in production to support existing customers, but TI does not recommend using this part in a new design.

PREVIEW: Device has been announced but is not in production. Samples may or may not be available.

OBSOLETE: TI has discontinued the production of the device.

(2) **RoHS:** TI defines "RoHS" to mean semiconductor products that are compliant with the current EU RoHS requirements for all 10 RoHS substances, including the requirement that RoHS substance do not exceed 0.1% by weight in homogeneous materials. Where designed to be soldered at high temperatures, "RoHS" products are suitable for use in specified lead-free processes. TI may reference these types of products as "Pb-Free".

RoHS Exempt: TI defines "RoHS Exempt" to mean products that contain lead but are compliant with EU RoHS pursuant to a specific EU RoHS exemption.

Green: TI defines "Green" to mean the content of Chlorine (Cl) and Bromine (Br) based flame retardants meet JS709B low halogen requirements of <=1000ppm threshold. Antimony trioxide based flame retardants must also meet the <=1000ppm threshold requirement.

(3) MSL, Peak Temp. - The Moisture Sensitivity Level rating according to the JEDEC industry standard classifications, and peak solder temperature.

(4) There may be additional marking, which relates to the logo, the lot trace code information, or the environmental category on the device.

(5) Multiple Device Markings will be inside parentheses. Only one Device Marking contained in parentheses and separated by a "-" will appear on a device. If a line is indented then it is a continuation of the previous line and the two combined represent the entire Device Marking for that device.

(6) Lead finish/Ball material - Orderable Devices may have multiple material finish options. Finish options are separated by a vertical ruled line. Lead finish/Ball material values may wrap to two lines if the finish value exceeds the maximum column width.

Important Information and Disclaimer: The information provided on this page represents TI's knowledge and belief as of the date that it is provided. TI bases its knowledge and belief on information provided by third parties, and makes no representation or warranty as to the accuracy of such information. Efforts are underway to better integrate information from third parties. TI has taken and continues to take reasonable steps to provide representative and accurate information but may not have conducted destructive testing or chemical analysis on incoming materials and chemicals. TI and TI suppliers consider certain information to be proprietary, and thus CAS numbers and other limited information may not be available for release.

In no event shall TI's liability arising out of such information exceed the total purchase price of the TI part(s) at issue in this document sold by TI to Customer on an annual basis.

GENERIC PACKAGE VIEW

PHP 48

TQFP - 1.2 mm max height

7 x 7, 0.5 mm pitch

QUAD FLATPACK

This image is a representation of the package family, actual package may vary.
Refer to the product data sheet for package details.

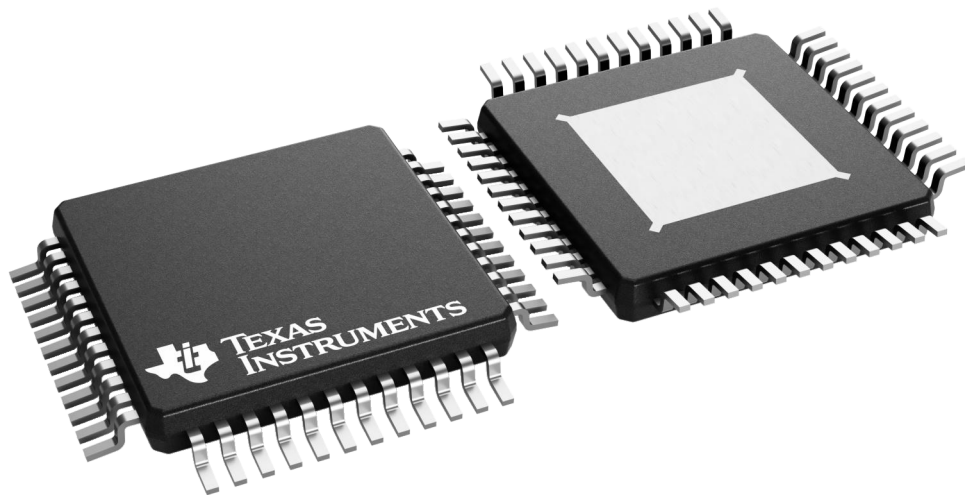

4226443/A

PACKAGE OUTLINE

PHP0048G

PowerPAD™ HTQFP - 1.2 mm max height

PLASTIC QUAD FLATPACK

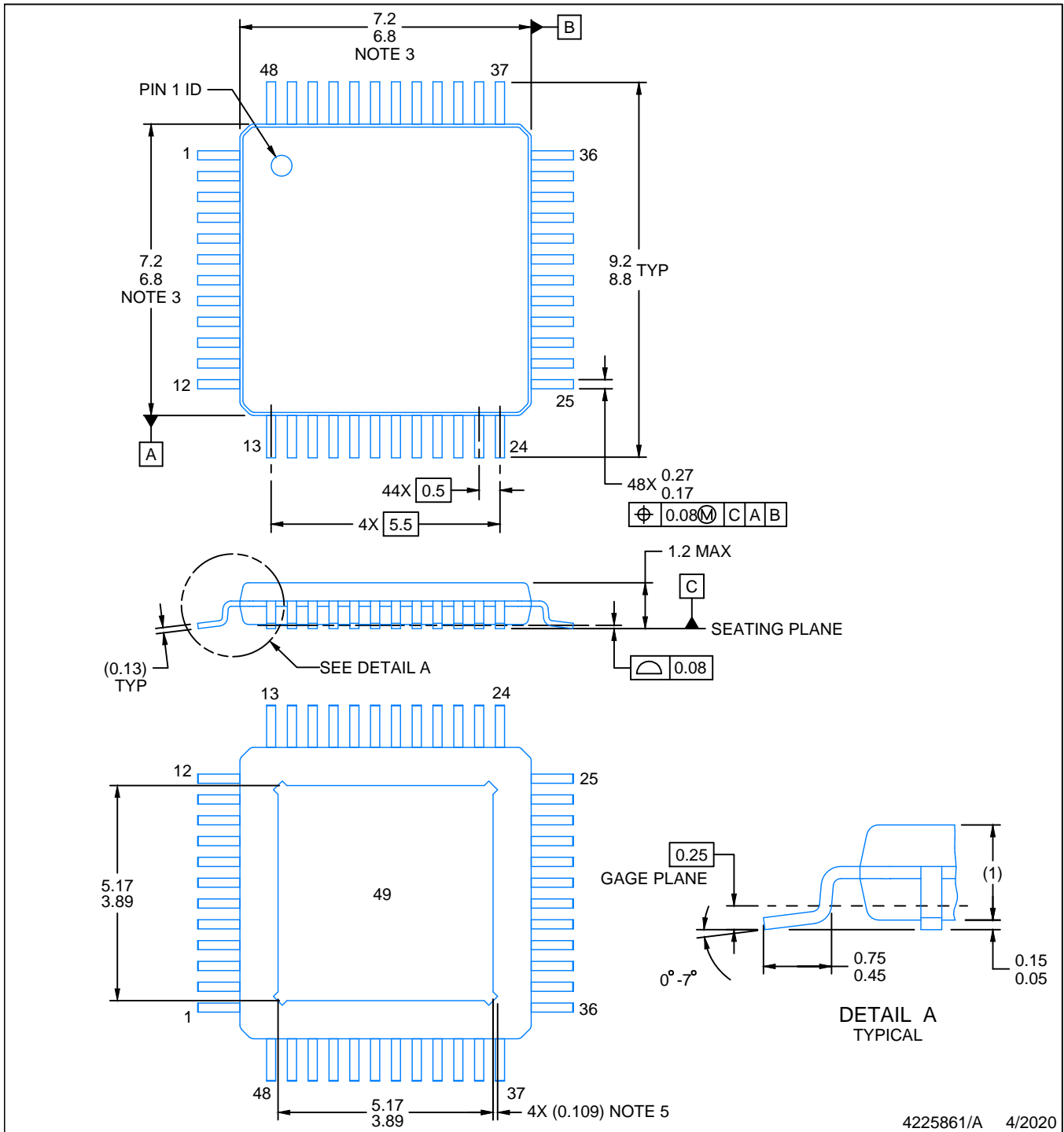

NOTES:

PowerPAD is a trademark of Texas Instruments.

1. All linear dimensions are in millimeters. Any dimensions in parenthesis are for reference only. Dimensioning and tolerancing per ASME Y14.5M.
2. This drawing is subject to change without notice.
3. This dimension does not include mold flash, protrusions, or gate burrs. Mold flash, protrusions, or gate burrs shall not exceed 0.15 mm per side.
4. Reference JEDEC registration MS-026.
5. Feature may not be present.

EXAMPLE BOARD LAYOUT

PHP0048G

PowerPAD™ HTQFP - 1.2 mm max height

PLASTIC QUAD FLATPACK

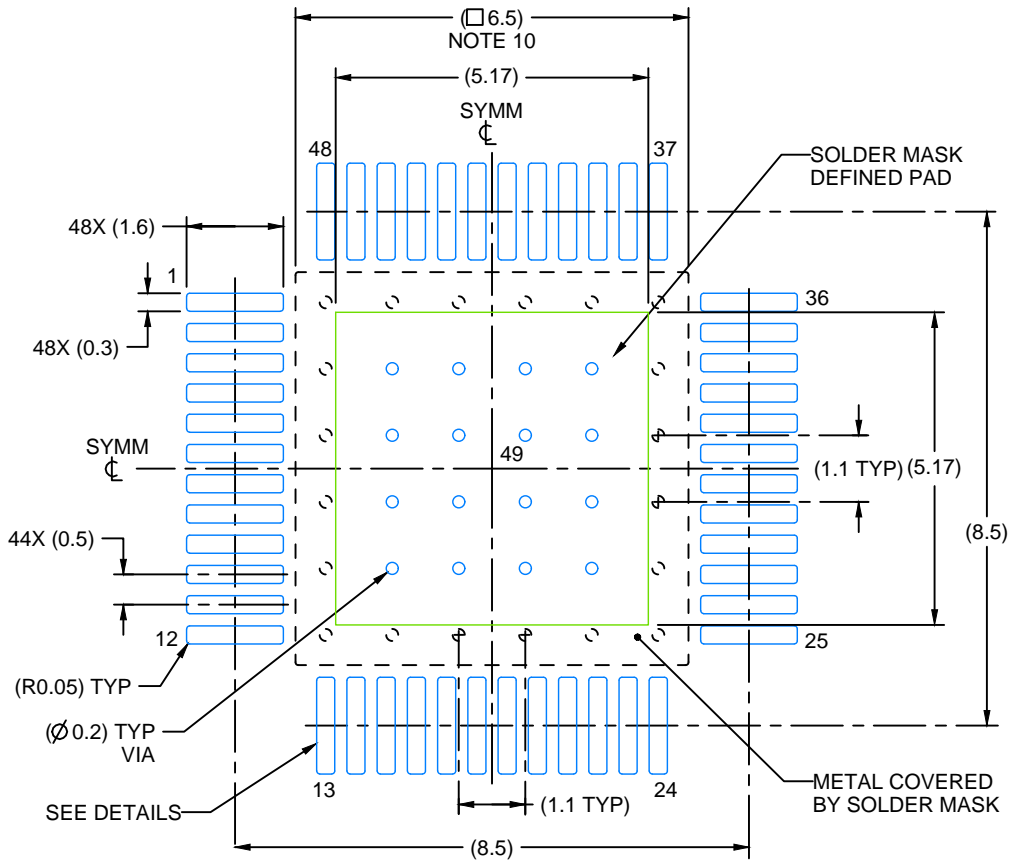

LAND PATTERN EXAMPLE
EXPOSED METAL SHOWN
SCALE:8X

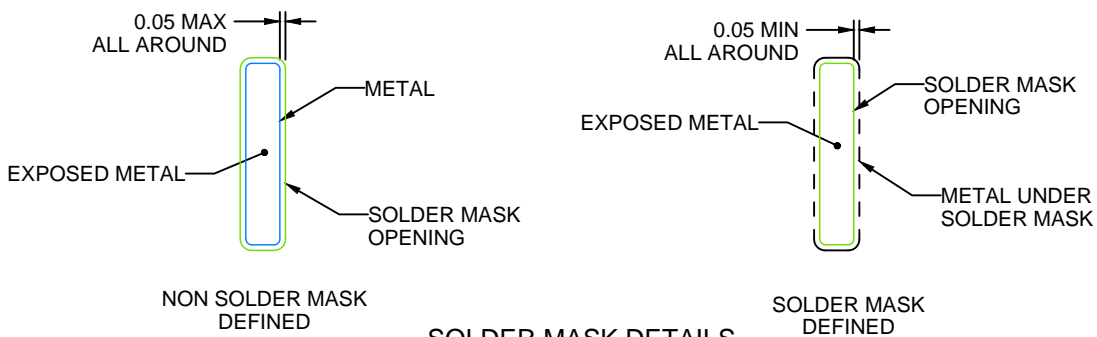

SOLDER MASK DETAILS

4225861/A 4/2020

NOTES: (continued)

6. Publication IPC-7351 may have alternate designs.
7. Solder mask tolerances between and around signal pads can vary based on board fabrication site.
8. This package is designed to be soldered to a thermal pad on the board. See technical brief, Powerpad thermally enhanced package, Texas Instruments Literature No. SLMA002 (www.ti.com/lit/slma002) and SLMA004 (www.ti.com/lit/slma004).
9. Vias are optional depending on application, refer to device data sheet. It is recommended that vias under paste be filled, plugged or tented.
10. Size of metal pad may vary due to creepage requirement.

EXAMPLE STENCIL DESIGN

PHP0048G

PowerPAD™ HTQFP - 1.2 mm max height

PLASTIC QUAD FLATPACK

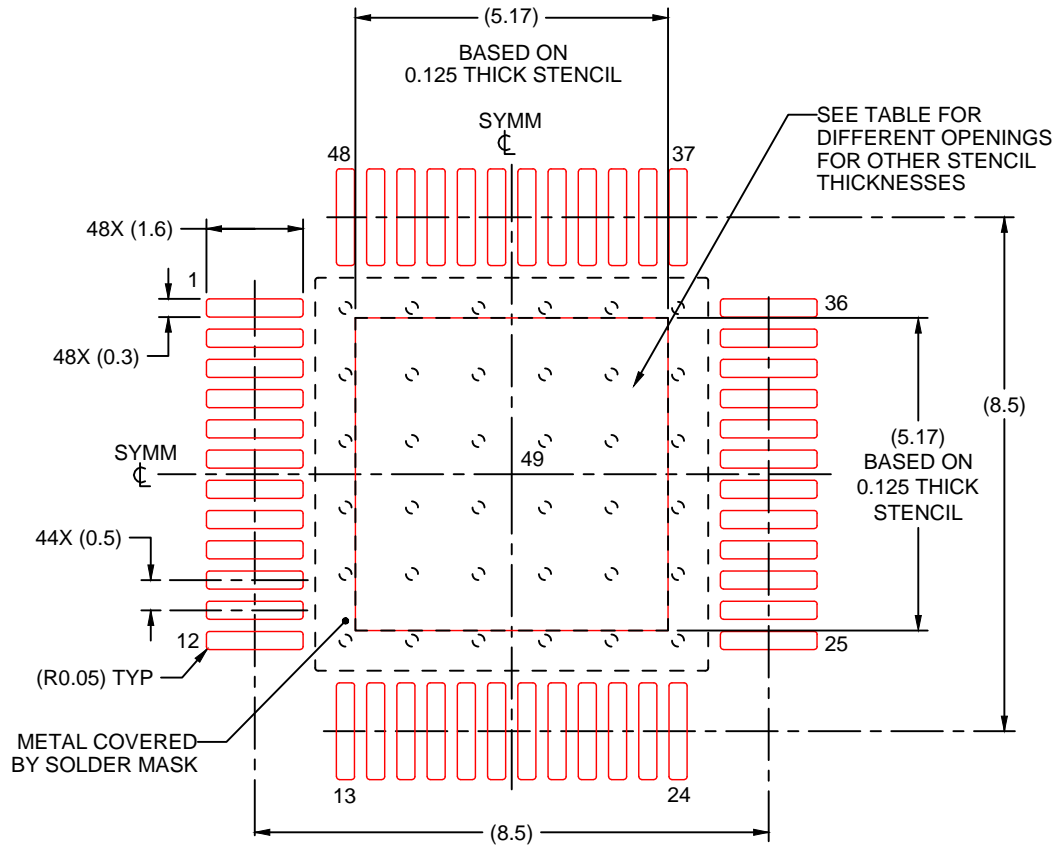

SOLDER PASTE EXAMPLE
EXPOSED PAD
100% PRINTED SOLDER COVERAGE BY AREA
SCALE:8X

STENCIL THICKNESS	SOLDER STENCIL OPENING
0.1	5.78 X 5.78
0.125	5.17 X 5.17 (SHOWN)
0.150	4.72 X 4.72
0.175	4.37 X 4.37

4225861/A 4/2020

NOTES: (continued)

11. Laser cutting apertures with trapezoidal walls and rounded corners may offer better paste release. IPC-7525 may have alternate design recommendations.
12. Board assembly site may have different recommendations for stencil design.

重要声明和免责声明

TI“按原样”提供技术和可靠性数据（包括数据表）、设计资源（包括参考设计）、应用或其他设计建议、网络工具、安全信息和其他资源，不保证没有瑕疵且不做任何明示或暗示的担保，包括但不限于对适销性、某特定用途方面的适用性或不侵犯任何第三方知识产权的暗示担保。

这些资源可供使用 TI 产品进行设计的熟练开发人员使用。您将自行承担以下全部责任：(1) 针对您的应用选择合适的 TI 产品，(2) 设计、验证并测试您的应用，(3) 确保您的应用满足相应标准以及任何其他功能安全、信息安全、监管或其他要求。

这些资源如有变更，恕不另行通知。TI 授权您仅可将这些资源用于研发本资源所述的 TI 产品的应用。严禁对这些资源进行其他复制或展示。您无权使用任何其他 TI 知识产权或任何第三方知识产权。您应全额赔偿因在这些资源的使用中对 TI 及其代表造成的任何索赔、损害、成本、损失和债务，TI 对此概不负责。

TI 提供的产品受 [TI 的销售条款](#) 或 [ti.com](#) 上其他适用条款/TI 产品随附的其他适用条款的约束。TI 提供这些资源并不会扩展或以其他方式更改 TI 针对 TI 产品发布的适用的担保或担保免责声明。

TI 反对并拒绝您可能提出的任何其他或不同的条款。

邮寄地址：Texas Instruments, Post Office Box 655303, Dallas, Texas 75265
Copyright © 2021，德州仪器 (TI) 公司