

LM2756 Multi-Display Inductorless LED Driver with 32 Exponential Dimming Steps in DSBGA

Check for Samples: [LM2756](#)

FEATURES

- Drives up to 8 LEDs with up to 30mA of Diode Current Each
- 32 Exponential Dimming Steps with 800:1 Dimming Ratio for Group A (Up to 6 LEDs)
- 8 Linear Dimming States for Groups B (Up to 3 LEDs) and D1C (1 LED)
- Programmable Auto-Dimming Function
- 3 Independently Controlled LED Groups Via I²C Compatible Interface
- Up to 90% Efficiency
- Total Solution Size < 21mm²
- Low Profile 20 Bump DSBGA Package (1.615mm × 2.015mm × 0.6mm)
- 0.4% Accurate Current Matching
- Internal Soft-Start Limits Inrush Current
- True Shutdown Isolation for LED's
- Wide Input Voltage Range (2.7V to 5.5V)
- Active High Hardware Enable

APPLICATIONS

- Dual Display LCD Backlighting for Portable Applications
- Large Format LCD Backlighting
- Display Backlighting with Indicator Light

DESCRIPTION

The LM2756 is a highly integrated, switched-capacitor, multi-display LED driver that can drive up to 8 LEDs in parallel with a total output current of 180mA. Regulated internal current sources deliver excellent current and brightness matching in all LEDs.

The LED driver current sinks are split into three independently controlled groups. The primary group (Group A) can be configured to drive four, five or six LEDs for use in the main phone display, while the secondary group (Group B) can be configured to drive one, two or three LEDs for driving secondary displays, keypads and/or indicator LEDs. An additional driver, D1C, is provided for additional indicator lighting functions.

Typical Application Circuit

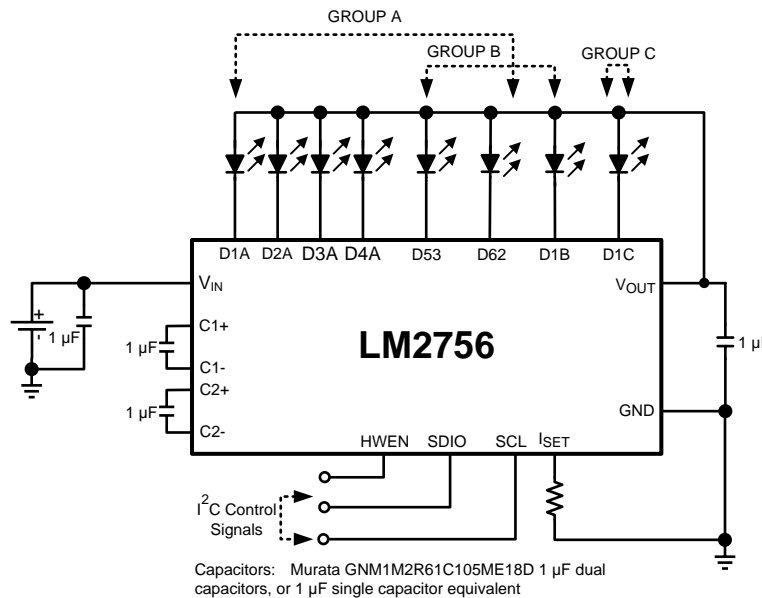

Please be aware that an important notice concerning availability, standard warranty, and use in critical applications of Texas Instruments semiconductor products and disclaimers thereto appears at the end of this data sheet.

All trademarks are the property of their respective owners.

DESCRIPTION (CONTINUED)

The device provides excellent efficiency without the use of an inductor by operating the charge pump in a gain of 3/2 or in Pass-Mode. The proper gain for maintaining current regulation is chosen, based on LED forward voltage, so that efficiency is maximized over the input voltage range.

The LM2756 is available in TI's tiny 20-bump, 0.4mm pitch, thin DSBGA package.

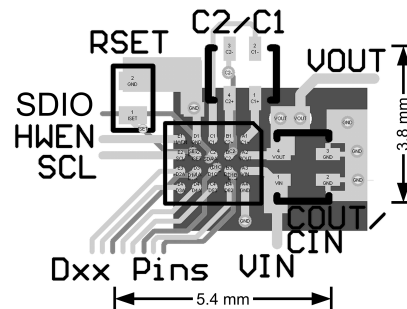

Figure 1. Minimum Layout

Connection Diagram

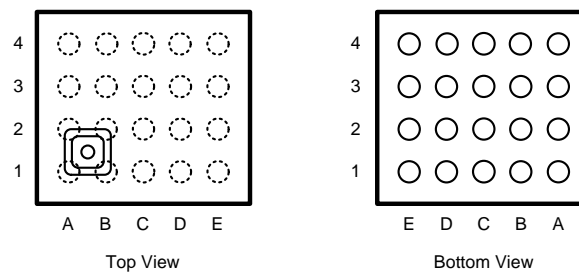

Figure 2. 20 Bump DSBGA Package
Package Number YFQ0020AAA

PIN DESCRIPTIONS

Bump #s YFQ0020AAA	Pin Names	Pin Descriptions
A3	V_{IN}	Input voltage. Input range: 2.7V to 5.5V.
A2	V_{OUT}	Charge Pump Output Voltage
A1, C1, B1, B2	C1+, C1-, C2+, C2-	Flying Capacitor Connections
D3, E3, E4, D4	D1A-D4A	LED Drivers - GroupA
C4, B4	D53, D62	LED Drivers - Configurable Current Sinks. Can be assigned to GroupA or GroupB
B3	D1B	LED Drivers - GroupB
C3	D1C	LED Driver - Indicator LED
D2	I_{SET}	Placing a resistor (R_{SET}) between this pin and GND sets the full-scale LED current for DxA, DxB, D53, D62 and D1C LEDs. Full-Scale LED Current = $189 \times (1.25V \div R_{SET})$
E1	HWEN	Hardware Enable Pin. High = Normal Operation, Low = RESET
C2	SDIO	Serial Data Input/Output Pin
E2	SCL	Serial Clock Pin
A4, D1	GND	Ground



These devices have limited built-in ESD protection. The leads should be shorted together or the device placed in conductive foam during storage or handling to prevent electrostatic damage to the MOS gates.

Absolute Maximum Ratings ⁽¹⁾⁽²⁾⁽³⁾

V _{IN} pin voltage	-0.3V to 6.0V
SCL, SDIO, HWEN pin voltages	-0.3V to (V _{IN} +0.3V) w/ 6.0V max
I _{Dxx} Pin Voltages	-0.3V to (V _{OUT} +0.3V) w/ 6.0V max
Continuous Power Dissipation (⁴)	Internally Limited
Junction Temperature (T _{J-MAX})	150°C
Storage Temperature Range	-65°C to +150°C
Maximum Lead Temperature (Soldering)	(⁵)
ESD Rating(⁶) Human Body Model	2.0kV

- (1) Absolute Maximum Ratings indicate limits beyond which damage to the component may occur. Operating Ratings are conditions under which operation of the device is ensured. Operating Ratings do not imply specified performance limits. For ensured performance limits and associated test conditions, see the Electrical Characteristics tables.
- (2) If Military/Aerospace specified devices are required, please contact the Texas Instruments Sales Office/ Distributors for availability and specifications.
- (3) All voltages are with respect to the potential at the GND pins.
- (4) Internal thermal shutdown circuitry protects the device from permanent damage. Thermal shutdown engages at T_J = 160°C (typ.) and disengages at T_J = 155°C (typ.).
- (5) For detailed soldering specifications and information, please refer to TI Application Note 1112: Micro SMD Wafer Level Chip Scale Package (AN-1112) [SNVA009](#).
- (6) The human body model is a 100pF capacitor discharged through a 1.5kΩ resistor into each pin. (MIL-STD-883 3015.7)

Operating Rating ⁽¹⁾⁽²⁾

Input Voltage Range	2.7V to 5.5V
LED Voltage Range	2.0V to 4.0V
Junction Temperature (T _J) Range	-30°C to +105°C
Ambient Temperature (T _A) Range(³)	-30°C to +85°C

- (1) Absolute Maximum Ratings indicate limits beyond which damage to the component may occur. Operating Ratings are conditions under which operation of the device is ensured. Operating Ratings do not imply specified performance limits. For ensured performance limits and associated test conditions, see the Electrical Characteristics tables.
- (2) All voltages are with respect to the potential at the GND pins.
- (3) In applications where high power dissipation and/or poor package thermal resistance is present, the maximum ambient temperature may have to be derated. Maximum ambient temperature (T_{A-MAX}) is dependent on the maximum operating junction temperature (T_{J-MAX-OP} = 105°C), the maximum power dissipation of the device in the application (P_{D-MAX}), and the junction-to ambient thermal resistance of the part/package in the application (θ_{JA}), as given by the following equation: T_{A-MAX} = T_{J-MAX-OP} – (θ_{JA} × P_{D-MAX}).

Thermal Properties

Junction-to-Ambient Thermal Resistance (θ _{JA}), YFQ0020 Package (¹)	40°C/W
---	--------

- (1) Junction-to-ambient thermal resistance is highly dependent on application and board layout. In applications where high maximum power dissipation exists, special care must be paid to thermal dissipation issues in board design. For more information, please refer to TI Application Note 1112: Micro SMD Wafer Level Chip Scale Package (AN-1112) [SNVA009](#).

Electrical Characteristics ⁽¹⁾⁽²⁾

Limits in standard typeface are for T_J = 25°C, and limits in boldface type apply over the full operating temperature range. Unless otherwise specified: V_{IN} = 3.6V; V_{HWEN} = V_{IN}; V_{DxA} = V_{DxB} = V_{DxC} = 0.4V; R_{SET} = 11.8kΩ; GroupA = GroupB = GroupC = Fullscale Current; ENA, ENB, ENC Bits = "1"; SD53, SD62, 53A, 62A Bits = "0"; C1 = C2 = C_{IN} = C_{OUT} = 1.0μF;

- (1) All voltages are with respect to the potential at the GND pins.
- (2) Min and Max limits are guaranteed by design, test, or statistical analysis. Typical numbers are not guaranteed, but do represent the most likely norm.

Electrical Characteristics⁽¹⁾⁽²⁾ (continued)

Limits in standard typeface are for $T_J = 25^\circ\text{C}$, and limits in boldface type apply over the full operating temperature range.

Unless otherwise specified: $V_{IN} = 3.6\text{V}$; $V_{HWEN} = V_{IN}$; $V_{DxA} = V_{DxB} = V_{DxC} = 0.4\text{V}$; $R_{SET} = 11.8\text{k}\Omega$; GroupA = GroupB = GroupC = Fullscale Current; ENA, ENB, ENC Bits = "1"; SD53, SD62, 53A, 62A Bits = "0"; $C_1 = C_2 = C_{IN} = C_{OUT} = 1.0\mu\text{F}$;

Specifications related to output current(s) and current setting pins (I_{Dxx} and I_{SET}) apply to GroupA and GroupB. ⁽³⁾

Specifications related to output current(s) and current setting pins (I_{Dxx} and I_{SET}) apply to GroupA and GroupB. ⁽³⁾

Symbol	Parameter	Condition	Min	Typ	Max	Units	
I_{Dxx}	Output Current Regulation GroupA	$2.7\text{V} \leq V_{IN} \leq 5.5\text{V}$ ENA = '1', 53A = 62A = '0', ENB = ENC = '0' 4 LEDs in GroupA	18.65 (-8%)	20.28	21.90 (+8%)	mA (%)	
		$2.7\text{V} \leq V_{IN} \leq 5.5\text{V}$ ENA = '1', 53A = 62A = '1', ENB = ENC = '0' 6 LEDs in GroupA	18.70 (-8.5%)	20.40	22.10 (+8.5%)	mA (%)	
	Output Current Regulation GroupB	$2.7\text{V} \leq V_{IN} \leq 5.5\text{V}$ ENB = '1', 53A = 62A = '0', ENA = ENC = '0' 3 LEDs in GroupB	18.40 (-8%)	20.00	21.60 (+8%)	mA (%)	
	Output Current Regulation IDC	$2.7\text{V} \leq V_{IN} \leq 5.5\text{V}$ ENC = '1', ENA = ENB = '0'	18.20 (-7.5%)	19.70	21.20 (+7.5%)	mA (%)	
	Maximum Diode Current per Dxx Output ⁽⁴⁾	$R_{SET} = 8.33\text{k}\Omega$		30		mA	
Output Current Regulation GroupA, GroupB, and GroupC Enabled ⁽⁴⁾	$3.2\text{V} \leq V_{IN} \leq 5.5\text{V}$ $V_{LED} = 3.6\text{V}$ $R_{SET} = 10.5\text{k}\Omega$			22.5 DxA		mA	
				22.5 DxB			
				22.5 DxC			
$I_{Dxx-MATCH}$	LED Current Matching ⁽⁵⁾	$2.7\text{V} \leq V_{IN} \leq 5.5\text{V}$	GroupA (4 LEDs)		0.4	1.8	%
			GroupA (6 LEDs)		1.0	2.7	
			GroupB (3 LEDs)		0.7	2.5	
V_{DxTH}	V_{Dxx} 1x to 3/2x Gain Transition Threshold	V_{DxA} and/or V_{DxB} Falling		150		mV	
V_{HR}	Current sink Headroom Voltage Requirement ⁽⁶⁾	$I_{Dxx} = 95\% \times I_{Dxx}(\text{nom.})$ ($I_{Dxx}(\text{nom.}) \approx 20\text{mA}$)		65		mV	
R_{OUT}	Open-Loop Charge Pump Output Resistance	Gain = 3/2		2.4		Ω	
		Gain = 1		0.9			
I_Q	Quiescent Supply Current	Gain = 1.5x, No Load		2.1	2.5	mA	
I_{SD}	Shutdown Supply Current	All ENx bits = "0"		3.7	5.5	μA	
V_{SET}	I_{SET} Pin Voltage	$2.7\text{V} \leq V_{IN} \leq 5.5\text{V}$		1.25		V	
$I_{DxA-B-C} / I_{SET}$	Output Current to Current Set Ratio GroupA, GroupB, GroupC			189			
f_{SW}	Switching Frequency		1.0	1.3	1.6	MHz	
t_{START}	Start-up Time	$V_{OUT} = 90\%$ steady state		250		μs	
V_{HWEN}	HWEN Voltage Thresholds	$2.7\text{V} \leq V_{IN} \leq 5.5\text{V}$	Reset	0		0.580	V
			Normal Operation	1.075		V_{IN}	
I²C Compatible Interface Voltage Specifications (SCL, SDIO)							

(3) C_{IN} , C_{VOUT} , C_1 , and C_2 : Low-ESR Surface-Mount Ceramic Capacitors (MLCCs) used in setting electrical characteristics

(4) The maximum total output current for the LM2756 should be limited to 180mA. The total output current can be split among any of the three Groups ($I_{DxA} = I_{DxB} = I_{DxC} = 30\text{mA Max.}$). Under maximum output current conditions, special attention must be given to input voltage and LED forward voltage to ensure proper current regulation. See the [Maximum Output Current](#) section of the datasheet for more information.

(5) For the two groups of current sinks on a part (GroupA and GroupB), the following are determined: the maximum sink current in the group (MAX), the minimum sink current in the group (MIN), and the average sink current of the group (AVG). For each group, two matching numbers are calculated: (MAX-AVG)/AVG and (AVG-MIN)/AVG. The largest number of the two (worst case) is considered the matching figure for the Group. The matching figure for a given part is considered to be the highest matching figure of the two Groups. The typical specification provided is the most likely norm of the matching figure for all parts.

(6) For each Dxxpin, headroom voltage is the voltage across the internal current sink connected to that pin. For Group A, B, and C current sinks, $V_{HRx} = V_{OUT} - V_{LED}$. If headroom voltage requirement is not met, LED current regulation will be compromised.

Electrical Characteristics⁽¹⁾⁽²⁾ (continued)

Limits in standard typeface are for $T_J = 25^\circ\text{C}$, and limits in boldface type apply over the full operating temperature range. Unless otherwise specified: $V_{IN} = 3.6\text{V}$; $V_{HWEN} = V_{IN}$; $V_{DxA} = V_{DxB} = V_{DxC} = 0.4\text{V}$; $R_{SET} = 11.8\text{k}\Omega$; GroupA = GroupB = GroupC = Fullscale Current; ENA, ENB, ENC Bits = "1"; SD53, SD62, 53A, 62A Bits = "0"; $C_1 = C_2 = C_{IN} = C_{OUT} = 1.0\mu\text{F}$; Specifications related to output current(s) and current setting pins (I_{Dxx} and I_{SET}) apply to GroupA and GroupB. ⁽³⁾

Symbol	Parameter	Condition	Min	Typ	Max	Units
V_{IL}	Input Logic Low "0"	$2.7\text{V} \leq V_{IN} \leq 5.5\text{V}$	0		0.710	V
V_{IH}	Input Logic High "1"	$2.7\text{V} \leq V_{IN} \leq 5.5\text{V}$	1.225		V_{IN}	V
V_{OL}	Output Logic Low "0"	$I_{LOAD} = 3.5\text{mA}$			400	mV
I²C Compatible Interface Timing Specifications (SCL, SDIO)⁽⁷⁾						
t_1	SCL (Clock Period)	⁽⁸⁾	294			ns
t_2	Data In Setup Time to SCL High		100			ns
t_3	Data Out stable After SCL Low		0			ns
t_4	SDIO Low Setup Time to SCL Low (Start)		100			ns
t_5	SDIO High Hold Time After SCL High (Stop)		100			ns

- (7) SCL and SDIO should be glitch-free in order for proper brightness control to be realized.
- (8) SCL is tested with a 50% duty-cycle clock.

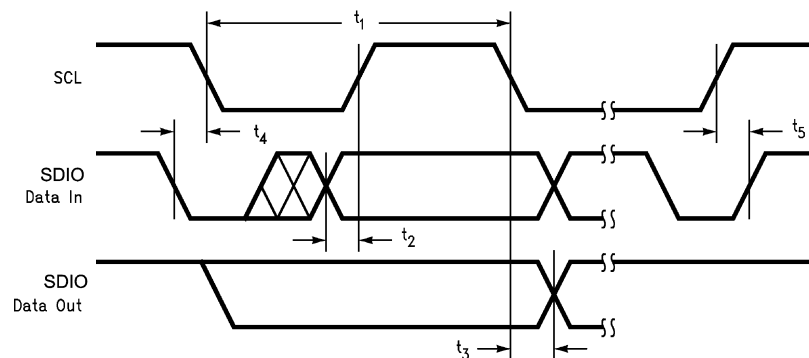
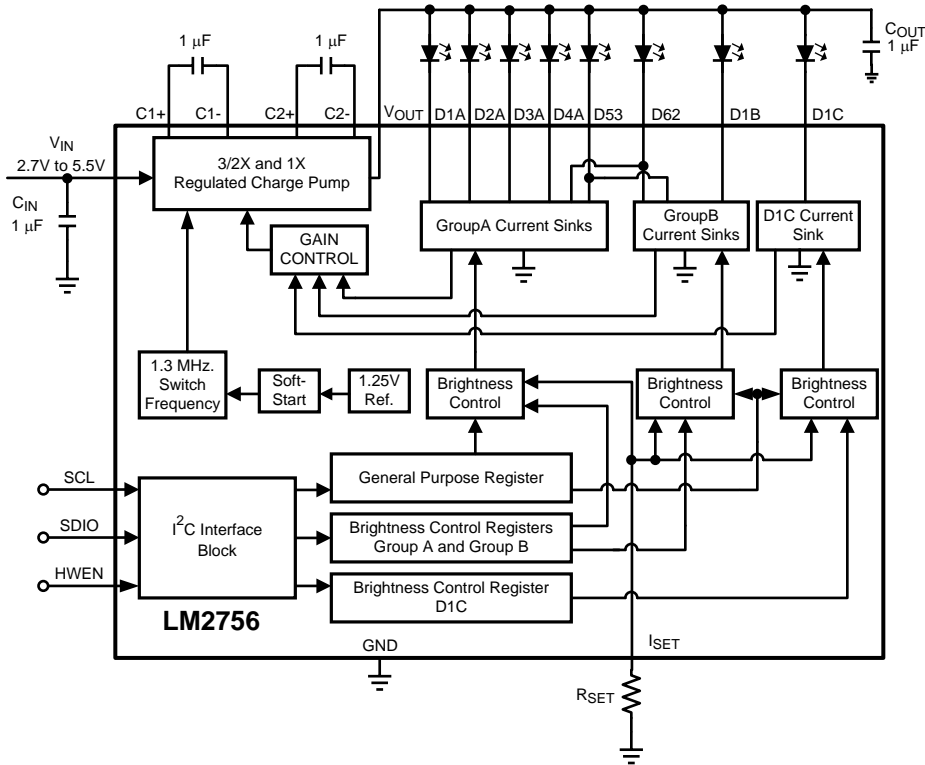

Figure 3.

BLOCK DIAGRAM



Typical Performance Characteristics

Unless otherwise specified: $T_A = 25^\circ\text{C}$; $V_{IN} = 3.6\text{V}$; $V_{HWEN} = V_{IN}$; $V_{LEDxA} = V_{LEDxB} = V_{LED1C} = 3.6\text{V}$; $R_{SET} = 11.8\text{k}\Omega$; $C_1=C_2=C_{IN} = C_{VOUT} = 1\mu\text{F}$; $ENA = ENB = ENC = '1'$.

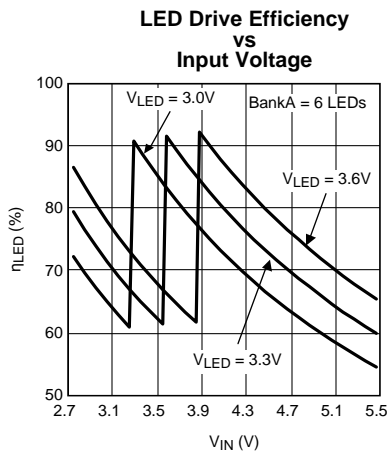

Figure 4.

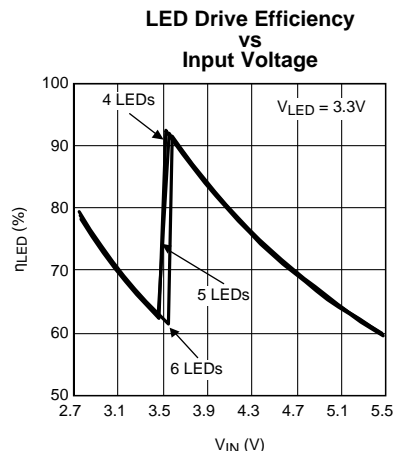

Figure 5.

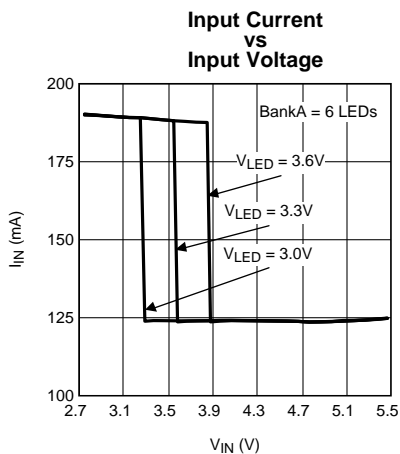

Figure 6.

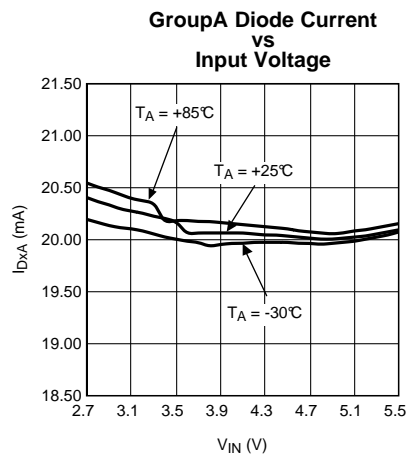

Figure 7.

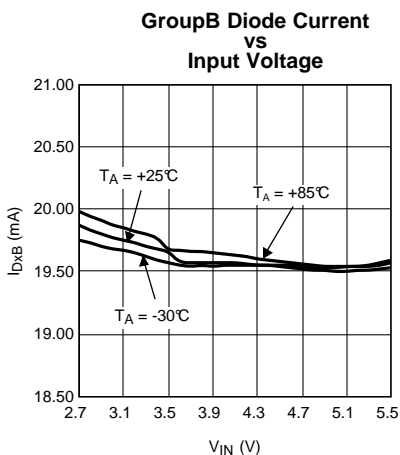

Figure 8.

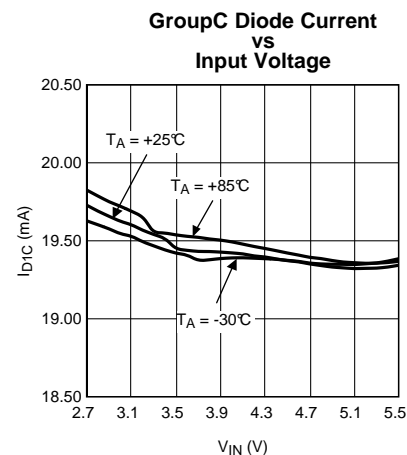

Figure 9.

Typical Performance Characteristics (continued)

Unless otherwise specified: $T_A = 25^\circ\text{C}$; $V_{IN} = 3.6\text{V}$; $V_{HWEN} = V_{IN}$; $V_{LEDxA} = V_{LEDxB} = V_{LED1C} = 3.6\text{V}$; $R_{SET} = 11.8\text{k}\Omega$; $C_1=C_2=C_{IN} = C_{VOUT} = 1\mu\text{F}$; $ENA = ENB = ENC = '1'$.

GroupA Current Matching vs Input Voltage 6 LEDs

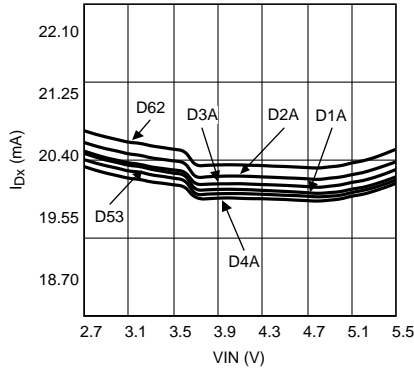

Figure 10.

GroupA Current Matching vs Input Voltage 4 LEDs

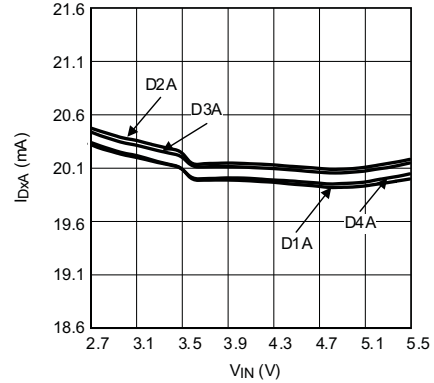

Figure 11.

GroupB Current Matching vs Input Voltage 3 LEDs

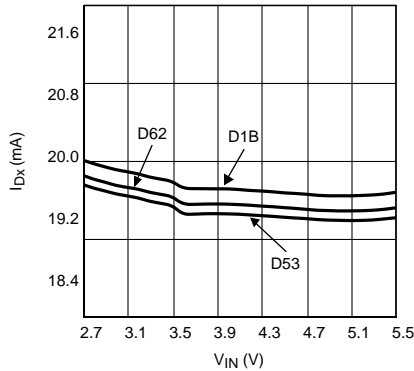

Figure 12.

GroupA Diode Current vs GroupA Brightness Code

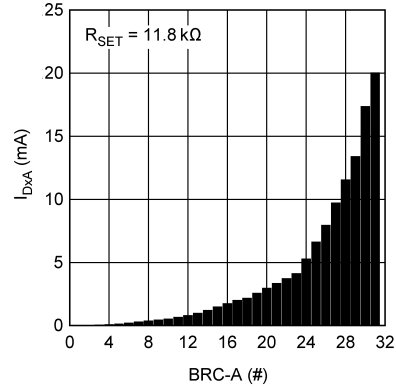

Figure 13.

GroupB Diode Current vs GroupB Brightness Code

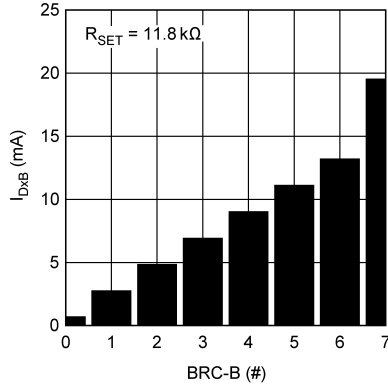

Figure 14.

GroupC Diode Current vs GroupC Brightness Code

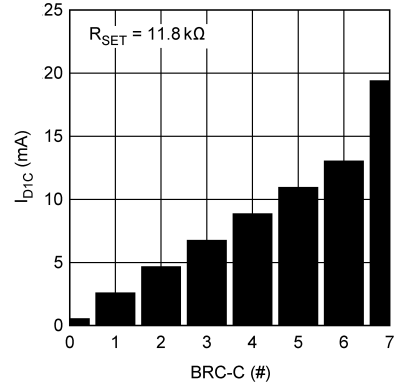
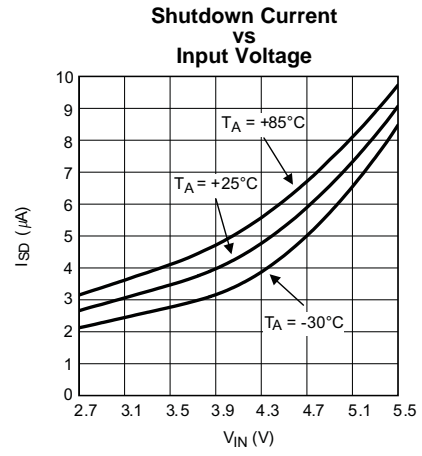
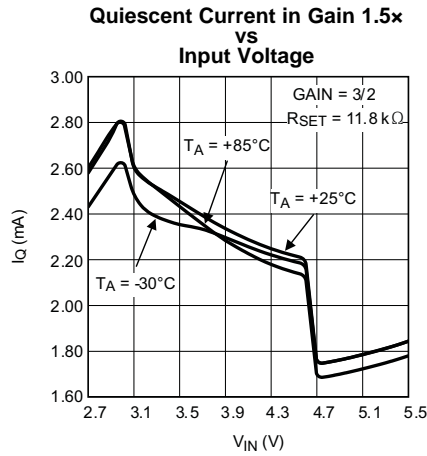

Figure 15.

Typical Performance Characteristics (continued)

Unless otherwise specified: $T_A = 25^\circ\text{C}$; $V_{IN} = 3.6\text{V}$; $V_{HWEN} = V_{IN}$; $V_{LEDxA} = V_{LEDxB} = V_{LED1C} = 3.6\text{V}$; $R_{SET} = 11.8\text{k}\Omega$; $C_1=C_2=C_{IN} = C_{VOUT} = 1\mu\text{F}$; $ENA = ENB = ENC = '1'$.



CIRCUIT DESCRIPTION

Overview

The LM2756 is a white LED driver system based upon an adaptive $3/2\times - 1\times$ CMOS charge pump capable of supplying up to 180mA of total output current. With three separately controlled Groups of constant current sinks, the LM2756 is an ideal solution for platforms requiring a single white LED driver for main display, sub display, and indicator lighting. The tightly matched current sinks ensure uniform brightness from the LEDs across the entire small-format display.

Each LED is configured in a common anode configuration, with the peak drive current being programmed through the use of an external R_{SET} resistor. An I²C compatible interface is used to enable the device and vary the brightness within the individual current sink Groups. For GroupA, 32 exponentially-spaced analog brightness control levels are available. GroupB and GroupC have 8 linearly-spaced analog brightness levels.

Circuit Components

Charge Pump

The input to the $3/2\times - 1\times$ charge pump is connected to the V_{IN} pin, and the regulated output of the charge pump is connected to the V_{OUT} pin. The recommended input voltage range of the LM2756 is 2.7V to 5.5V. The device's regulated charge pump has both open loop and closed loop modes of operation. When the device is in open loop, the voltage at V_{OUT} is equal to the gain times the voltage at the input. When the device is in closed loop, the voltage at V_{OUT} is regulated to 4.6V (typ.). The charge pump gain transitions are actively selected to maintain regulation based on LED forward voltage and load requirements.

LED Forward Voltage Monitoring

The LM2756 has the ability to switch gains ($1\times$ or $3/2\times$) based on the forward voltage of the LED load. This ability to switch gains maximizes efficiency for a given load. Forward voltage monitoring occurs on all diode pins. At higher input voltages, the LM2756 will operate in pass mode, allowing the V_{OUT} voltage to track the input voltage. As the input voltage drops, the voltage on the Dxx pins will also drop ($V_{DXX} = V_{VOUT} - V_{LEDX}$). Once any of the active Dxx pins reaches a voltage approximately equal to 150mV, the charge pump will switch to the gain of $3/2$. This switch-over ensures that the current through the LEDs never becomes pinched off due to a lack of headroom across the current sinks. **Once a gain transition occurs, the LM2756 will remain in the gain of $3/2$ until an I²C write to the part occurs. At that time, the LM2756 will re-evaluate the LED conditions and select the appropriate gain.**

Only active Dxx pins will be monitored. For example, if only GroupA is enabled, the LEDs in GroupB or GroupC will not affect the gain transition point. If all 3 Groups are enabled, all diodes will be monitored, and the gain transition will be based upon the diode with the highest forward voltage.

Configurable Gain Transition Delay

To optimize efficiency, the LM2756 has a user selectable gain transition delay that allows the part to ignore short duration input voltage drops. By default, the LM2756 will not change gains if the input voltage dip is shorter than 3 to 6 milliseconds. There are four selectable gain transition delay ranges available on the LM2756. All delay ranges are set within the VF Monitor Delay Register. Please refer to the [Internal Registers of LM2756](#) section of this datasheet for more information regarding the delay ranges.

HWEN Pin

The LM2756 has a hardware enable/reset pin (HWEN) that allows the device to be disabled by an external controller without requiring an I²C write command. Under normal operation, the HWEN pin should be held high (logic '1') to prevent an unwanted reset. When the HWEN is driven low (logic '0'), all internal control registers reset to the default states and the part becomes disabled. Please see the [Electrical Characteristics](#) section of the datasheet for required voltage thresholds.

I²C Compatible Interface

Data Validity

The data on SDIO line must be stable during the HIGH period of the clock signal (SCL). In other words, state of the data line can only be changed when SCL is LOW.

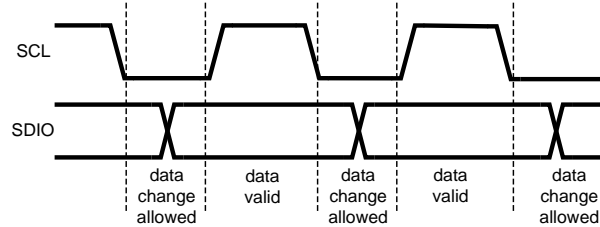

Figure 18. Data Validity Diagram

A pull-up resistor between the controller's V_{IO} line and SDIO must be greater than $[(V_{IO} - V_{OL}) / 3.5\text{mA}]$ to meet the V_{OL} requirement on SDIO. Using a larger pull-up resistor results in lower switching current with slower edges, while using a smaller pull-up results in higher switching currents with faster edges.

Start and Stop Conditions

START and STOP conditions classify the beginning and the end of the I²C session. A START condition is defined as SDIO signal transitioning from HIGH to LOW while SCL line is HIGH. A STOP condition is defined as the SDIO transitioning from LOW to HIGH while SCL is HIGH. The I²C master always generates START and STOP conditions. The I²C bus is considered to be busy after a START condition and free after a STOP condition. During data transmission, the I²C master can generate repeated START conditions. First START and repeated START conditions are equivalent, function-wise.

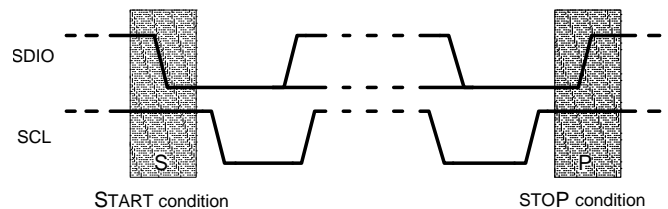
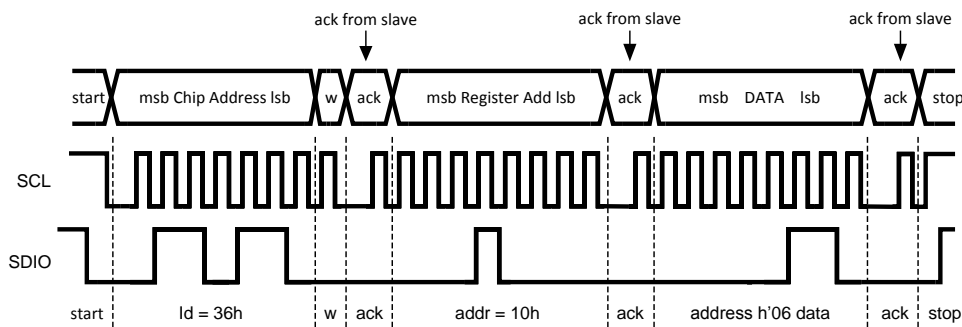

Figure 19. Start and Stop Conditions

Transferring Data

Every byte put on the SDIO line must be eight bits long, with the most significant bit (MSB) transferred first. Each byte of data has to be followed by an acknowledge bit. The acknowledge related clock pulse is generated by the master. The master releases the SDIO line (HIGH) during the acknowledge clock pulse. The LM2756 pulls down the SDIO line during the 9th clock pulse, signifying an acknowledge. The LM2756 generates an acknowledge after each byte is received.

After the START condition, the I²C master sends a chip address. This address is seven bits long followed by an eighth bit which is a data direction bit (R/W). The LM2756 address is 36h. For the eighth bit, a "0" indicates a WRITE and a "1" indicates a READ. The second byte selects the register to which the data will be written. The third byte contains data to write to the selected register.



w = write (SDIO = "0")
 r = read (SDIO = "1")
 ack = acknowledge (SDIO pulled down by either master or slave)
 id = chip address, 36h for LM2756

Figure 20. Write Cycle

I²C Compatible Chip Address

The chip address for LM2756 is 0110110, or 36h.

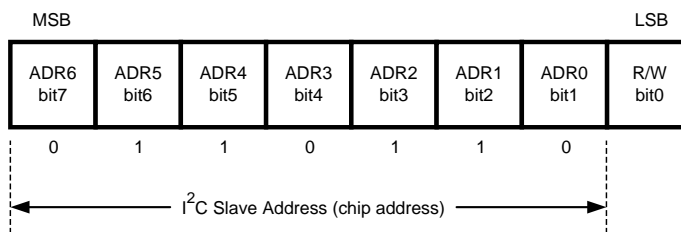
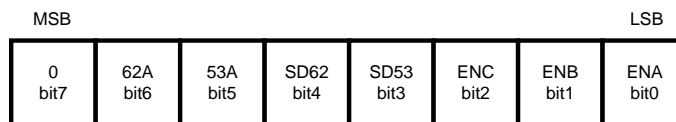

Figure 21. Chip Address

Internal Registers of LM2756

Register	Internal Hex Address	Power On Value
General Purpose Register	10h	0000 0000
Group A Brightness Control Register	A0h	1110 0000
Group B Brightness Control Register	B0h	1111 1000
Group C Brightness Control Register	C0h	1111 1000
Ramp Step Time Register	20h	1111 0000
VF Monitor Delay Register	60h	1111 1100



**Figure 22. General Purpose Register Description
 Internal Hex Address: 10h**

NOTE

- ENA: Enables DxA LED drivers (Main Display)
- ENB: Enables DxB LED drivers (Aux Lighting)
- ENC: Enables D1C LED driver (Indicator Lighting)
- SD53: Shuts down driver D53
- SD62: Shuts down driver D62
- 53A: Configures D53 to GroupA
- 62A: Configures D62 to GroupA

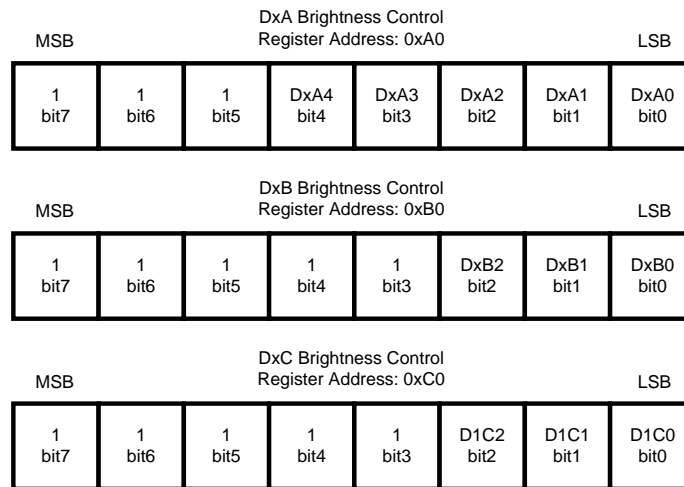

Figure 23. Brightness Control Register Description
Internal Hex Address: 0xA0 (GroupA), 0xB0 (GroupB), 0xC0 (GroupC)

NOTE

- DxA4-DxA0, D53, D62: Sets Brightness for DxA pins (GroupA). 11111=Fullscale
- DxB2-DxB0: Sets Brightness for DxB pins (GroupB). 111=Fullscale
- DxC2-DxC0: Sets Brightness for D1C pin. 111 = Fullscale
- Full-Scale Current set externally by the following equation:

$$I_{Dxx} = 189 \times 1.25V / R_{SET}$$

Table 1. Brightness Level Control Table (GroupA)

Brightness Code (hex)	Perceived Brightness Level (%)
00	0.125
01	0.313
02	0.625
03	1
04	1.125
05	1.313
06	1.688
07	2.063
08	2.438
09	2.813
0A	3.125

Table 1. Brightness Level Control Table (GroupA) (continued)

Brightness Code (hex)	Perceived Brightness Level (%)
0B	3.75
0C	4.375
0D	5.25
0E	6.25
0F	7.5
10	8.75
11	10
12	12.5
13	15
14	16.875
15	18.75
16	22.5
17	26.25
18	31.25
19	37.5
1A	43.75
1B	52.5
1C	61.25
1D	70
1E	87.5
1F	100

GroupB and GroupC Brightness Levels (% of Full-Scale) = 10%, 20%, 30%, 40%, 50%, 60%, 70%, 100%

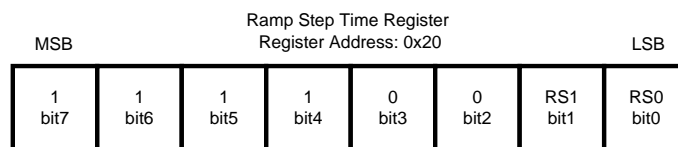

Figure 24. Ramp Step Time Register Description
Internal Hex Address: 20h

NOTE

RS1-RS0: Sets Brightness Ramp Step Time. The Brightness ramp settings only affect GroupA current sinks. ('00' = 100 μ s, '01' = 25ms, '10' = 50ms, '11' = 100ms).

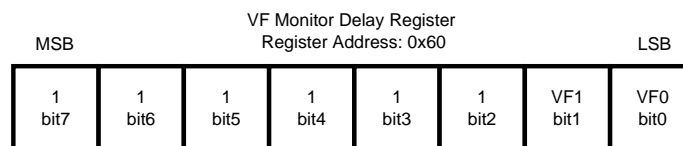

Figure 25. VF Monitor Delay Register Description
Internal Hex Address: 60h

NOTE

VF1-VF0: Sets the Gain Transition Delay Time. The VF Monitor Delay can be set to four different delay times. ('00' (Default) = 3-6msec., '01' = 1.5-3msec., '10' = 0.4-0.8msec., '11' = 60-90 μ sec.).

Application Information

Led configurations

The LM2756 has a total of 8 current sinks capable of sinking 180mA of total diode current. These 8 current sinks are configured to operate in three independently controlled lighting regions. GroupA has four dedicated current sinks, while GroupB and GroupC each have one. To add greater lighting flexibility, the LM2756 has two additional drivers (D53 and D62) that can be assigned to either GroupA or GroupB through a setting in the general purpose register.

At start-up, the default condition is four LEDs in GroupA, three LEDs in GroupB and a single LED in GroupC (NOTE: GroupC only consists of a single current sink (D1C) under any configuration). Bits 53A and 62A in the general purpose register control where current sinks D53 and D62 are assigned. By writing a '1' to the 53A or 62A bits, D53 and D62 become assigned to the GroupA lighting region. Writing a '0' to these bits assigns D53 and D62 to the GroupB lighting region. With this added flexibility, the LM2756 is capable of supporting applications requiring 4, 5, or 6 LEDs for main display lighting, while still providing additional current sinks that can be used for a wide variety of lighting functions.

Setting LED Current

The current through the LEDs connected to DxA and DxB can be set to a desired level simply by connecting an appropriately sized resistor (R_{SET}) between the I_{SET} pin of the LM2756 and GND. The DxA, DxB and D1C LED currents are proportional to the current that flows out of the I_{SET} pin and are a factor of 189 times greater than the I_{SET} current. The feedback loops of the internal amplifiers set the voltage of the I_{SET} pin to 1.25V (typ.). The statements above are simplified in the equations below:

$$I_{DxA/B/C} \text{ (A)} = 189 \times (V_{ISET} / R_{SET}) \quad (1)$$

$$R_{SET} \text{ (\Omega)} = 189 \times (1.25V / I_{DxA/B/C}) \quad (2)$$

Once the desired R_{SET} value has been chosen, the LM2756 has the ability to internally dim the LEDs using analog current scaling. The analog current level is set through the I²C compatible interface. LEDs connected to GroupA can be dimmed to 32 different levels. GroupB and GroupC(D1C) have 8 analog current levels.

Please refer to the [I²C Compatible Interface](#) section of this datasheet for detailed instructions on how to adjust the brightness control registers.

LED Current Ramping

The LM2756 provides an internal LED current ramping function that allows the GroupA LEDs to turn on and turn off gradually over time. The target current level is set in the GroupA Brightness Control Register (0xA0). The total ramp-up/ramp-down time is determined by the GroupA brightness level (0-31) and the user configurable ramp step time.

Bits RS1 and RS2 in the Ramp Step Time Register (0x20) set the ramp step time to the following four times: **'00' = 100µsec.**, **'01' = 25msec.**, **'10' = 50msec.**, **'11' = 100msec.**

The LM2756 will always ramp-up (upon enable) and ramp-down (upon disable) through the brightness levels until the target level is reached. At the default setting of '00', the LM2756's current ramping feature looks more like a current step rather than a current ramp. [Table 2](#) gives the approximate ramp-up/ramp-down times if the GroupA brightness register is set to full-scale, or brightness code 31.

Table 2. Brightness Ramp-Up/Ramp-Down Times

Ramp Code RS1-RS0	Ramp Step Time	Total Ramp Time
00	100µs	3.2ms
01	25ms	0.8s
10	50ms	1.6s
11	100ms	3.2s

Maximum Output Current, Maximum LED Voltage, Minimum Input Voltage

The LM2756 can drive 8 LEDs at 22.5mA each (GroupA, GroupB, GroupC) from an input voltage as low as 3.2V, so long as the LEDs have a forward voltage of 3.6V or less (room temperature).

The statement above is a simple example of the LED drive capability of the LM2756. The statement contains the key application parameters that are required to validate an LED-drive design using the LM2756: LED current (I_{LEDx}), number of active LEDs (N_x), LED forward voltage (V_{LED}), and minimum input voltage (V_{IN-MIN}).

The equation below can be used to estimate the maximum output current capability of the LM2756:

$$I_{LED_MAX} = [(1.5 \times V_{IN}) - V_{LED} - (I_{ADDITIONAL} \times R_{OUT})] / [(N_x \times R_{OUT}) + k_{HRx}] \quad (3)$$

$$I_{LED_MAX} = [(1.5 \times V_{IN}) - V_{LED} - (I_{ADDITIONAL} \times 2.4\Omega)] / [(N_x \times 2.4\Omega) + k_{HRx}] \quad (4)$$

$I_{ADDITIONAL}$ is the additional current that could be delivered to the other LED Groups.

R_{OUT} – Output resistance. This parameter models the internal losses of the charge pump that result in voltage droop at the pump output V_{OUT} . Since the magnitude of the voltage droop is proportional to the total output current of the charge pump, the loss parameter is modeled as a resistance. The output resistance of the LM2756 is typically 2.4 Ω ($V_{IN} = 3.6V$, $T_A = 25^\circ C$). In equation form:

$$V_{VOUT} = (1.5 \times V_{IN}) - [(N_A \times I_{LEDA} + N_B \times I_{LEDB} + N_C \times I_{LEDC}) \times R_{OUT}] \quad (5)$$

k_{HR} – Headroom constant. This parameter models the minimum voltage required to be present across the current sinks for them to regulate properly. This minimum voltage is proportional to the programmed LED current, so the constant has units of mV/mA. The typical k_{HR} of the LM2756 is 3.25mV/mA. In equation form:

$$(V_{VOUT} - V_{LEDx}) > k_{HRx} \times I_{LEDx} \quad (6)$$

$$\text{Typical Headroom Constant Values } k_{HRA} = k_{HRB} = k_{HRC} = 3.25 \text{ mV/mA} \quad (7)$$

The " $I_{LED-MAX}$ " equation (Equation 3) is obtained from combining the R_{OUT} equation (Equation 5) with the k_{HRx} equation (Equation 6) and solving for I_{LEDx} . Maximum LED current is highly dependent on minimum input voltage and LED forward voltage. Output current capability can be increased by raising the minimum input voltage of the application, or by selecting an LED with a lower forward voltage. Excessive power dissipation may also limit output current capability of an application.

Total Output Current Capability

The maximum output current that can be drawn from the LM2756 is 180mA. Each driver Group has a maximum allotted current per Dxx sink that must not be exceeded.

DRIVER TYPE	MAXIMUM Dxx CURRENT
DxA	30mA per DxA Pin
DxB	30mA per DxB Pin
D1C	30mA

The 180mA load can be distributed in many different configurations. Special care must be taken when running the LM2756 at the maximum output current to ensure proper functionality.

Parallel Connected and Unused Outputs

Connecting the outputs in parallel does not affect internal operation of the LM2756 and has no impact on the Electrical Characteristics and limits previously presented. The available diode output current, maximum diode voltage, and all other specifications provided in the [Electrical Characteristics](#) table apply to this parallel output configuration, just as they do to the standard LED application circuit.

All Dx current sinks utilize LED forward voltage sensing circuitry to optimize the charge-pump gain for maximum efficiency. Due to the nature of the sensing circuitry, it is not recommended to leave any of the DxA (D1A-D4A, D53, D62) pins open if diode GroupA is going to be used during normal operation. Leaving DxA pins unconnected will force the charge-pump into 3/2x mode over the entire V_{IN} range negating any efficiency gain that could have been achieved by switching to 1x mode at higher input voltages.

If the D1B or D1C drivers are not going to be used, make sure that the ENB and ENC bits in the general purpose register are set to '0' to ensure optimal efficiency.

The D53 and D62 pins can be completely shutdown through the general purpose register by writing a '1' to the SD53 or SD62 bits.

Care must be taken when selecting the proper R_{SET} value. The current on any DxX pin must not exceed the maximum current rating for any given current sink pin.

Power Efficiency

Efficiency of LED drivers is commonly taken to be the ratio of power consumed by the LEDs (P_{LED}) to the power drawn at the input of the part (P_{IN}). With a 3/2x - 1x charge pump, the input current is equal to the charge pump gain times the output current (total LED current). The efficiency of the LM2756 can be predicted as follow:

$$P_{LEDTOTAL} = (V_{LEDA} \times N_A \times I_{LEDA}) + (V_{LEDB} \times N_B \times I_{LEDB}) + (V_{LEDC} \times I_{LEDC}) \quad (8)$$

$$P_{IN} = V_{IN} \times I_{IN} \quad (9)$$

$$P_{IN} = V_{IN} \times (GAIN \times I_{LEDTOTAL} + I_Q) \quad (10)$$

$$E = (P_{LEDTOTAL} \div P_{IN}) \quad (11)$$

The LED voltage is the main contributor to the charge-pump gain selection process. Use of low forward-voltage LEDs (3.0V- to 3.5V) will allow the LM2756 to stay in the gain of 1x for a higher percentage of the lithium-ion battery voltage range when compared to the use of higher forward voltage LEDs (3.5V to 4.0V). See the [LED Forward Voltage Monitoring](#) section of this datasheet for a more detailed description of the gain selection and transition process.

For an advanced analysis, it is recommended that power consumed by the circuit ($V_{IN} \times I_{IN}$) for a given load be evaluated rather than power efficiency.

Power Dissipation

The power dissipation (P_{DISS}) and junction temperature (T_J) can be approximated with the equations below. P_{IN} is the power generated by the 3/2x - 1x charge pump, P_{LED} is the power consumed by the LEDs, T_A is the ambient temperature, and θ_{JA} is the junction-to-ambient thermal resistance for the DSBGA 20-bump package. V_{IN} is the input voltage to the LM2756, V_{LED} is the nominal LED forward voltage, N is the number of LEDs and I_{LED} is the programmed LED current.

$$P_{DISS} = P_{IN} - P_{LEDA} - P_{LEDB} - P_{LEDC} \quad (12)$$

$$P_{DISS} = (GAIN \times V_{IN} \times I_{GroupA + GroupB + GroupC}) - (V_{LEDA} \times N_A \times I_{LEDA}) - (V_{LEDB} \times N_B \times I_{LEDB}) - (V_{LEDC} \times I_{LEDC}) \quad (13)$$

$$T_J = T_A + (P_{DISS} \times \theta_{JA}) \quad (14)$$

The junction temperature rating takes precedence over the ambient temperature rating. The LM2756 may be operated outside the ambient temperature rating, so long as the junction temperature of the device does not exceed the maximum operating rating of 105°C. The maximum ambient temperature rating must be derated in applications where high power dissipation and/or poor thermal resistance causes the junction temperature to exceed 105°C.

Thermal Protection

Internal thermal protection circuitry disables the LM2756 when the junction temperature exceeds 160°C (typ.). This feature protects the device from being damaged by high die temperatures that might otherwise result from excessive power dissipation. The device will recover and operate normally when the junction temperature falls below 155°C (typ.). It is important that the board layout provide good thermal conduction to keep the junction temperature within the specified operating ratings.

Capacitor selection

The LM2756 requires 4 external capacitors for proper operation ($C_1 = C_2 = C_{IN} = C_{OUT} = 1\mu F$). Surface-mount multi-layer ceramic capacitors are recommended. These capacitors are small, inexpensive and have very low equivalent series resistance (ESR <20mΩ typ.). Tantalum capacitors, OS-CON capacitors, and aluminum electrolytic capacitors are not recommended for use with the LM2756 due to their high ESR, as compared to ceramic capacitors.

For most applications, ceramic capacitors with X7R or X5R temperature characteristic are preferred for use with the LM2756. These capacitors have tight capacitance tolerance (as good as ±10%) and hold their value over temperature (X7R: ±15% over -55°C to 125°C; X5R: ±15% over -55°C to 85°C).

Capacitors with Y5V or Z5U temperature characteristic are generally not recommended for use with the LM2756. Capacitors with these temperature characteristics typically have wide capacitance tolerance (+80%, -20%) and vary significantly over temperature (Y5V: +22%, -82% over -30°C to +85°C range; Z5U: +22%, -56% over +10°C to +85°C range). Under some conditions, a nominal 1 μ F Y5V or Z5U capacitor could have a capacitance of only 0.1 μ F. Such detrimental deviation is likely to cause Y5V and Z5U capacitors to fail to meet the minimum capacitance requirements of the LM2756.

The recommended voltage rating for the capacitors is 10V to account for DC bias capacitance losses.

REVISION HISTORY

Changes from Revision B (May 2013) to Revision C	Page
• Changed layout of National Data Sheet to TI format	18

PACKAGING INFORMATION

Orderable Device	Status (1)	Package Type	Package Drawing	Pins	Package Qty	Eco Plan (2)	Lead finish/ Ball material (6)	MSL Peak Temp (3)	Op Temp (°C)	Device Marking (4/5)	Samples
LM2756TM/NOPB	ACTIVE	DSBGA	YFQ	20	250	RoHS & Green	SNAGCU	Level-1-260C-UNLIM	-30 to 85	DK	Samples
LM2756TMX/NOPB	ACTIVE	DSBGA	YFQ	20	3000	RoHS & Green	SNAGCU	Level-1-260C-UNLIM	-30 to 85	DK	Samples

(1) The marketing status values are defined as follows:

ACTIVE: Product device recommended for new designs.

LIFEBUY: TI has announced that the device will be discontinued, and a lifetime-buy period is in effect.

NRND: Not recommended for new designs. Device is in production to support existing customers, but TI does not recommend using this part in a new design.

PREVIEW: Device has been announced but is not in production. Samples may or may not be available.

OBSELETE: TI has discontinued the production of the device.

(2) **RoHS:** TI defines "RoHS" to mean semiconductor products that are compliant with the current EU RoHS requirements for all 10 RoHS substances, including the requirement that RoHS substance do not exceed 0.1% by weight in homogeneous materials. Where designed to be soldered at high temperatures, "RoHS" products are suitable for use in specified lead-free processes. TI may reference these types of products as "Pb-Free".

RoHS Exempt: TI defines "RoHS Exempt" to mean products that contain lead but are compliant with EU RoHS pursuant to a specific EU RoHS exemption.

Green: TI defines "Green" to mean the content of Chlorine (Cl) and Bromine (Br) based flame retardants meet JS709B low halogen requirements of <=1000ppm threshold. Antimony trioxide based flame retardants must also meet the <=1000ppm threshold requirement.

(3) MSL, Peak Temp. - The Moisture Sensitivity Level rating according to the JEDEC industry standard classifications, and peak solder temperature.

(4) There may be additional marking, which relates to the logo, the lot trace code information, or the environmental category on the device.

(5) Multiple Device Markings will be inside parentheses. Only one Device Marking contained in parentheses and separated by a "~" will appear on a device. If a line is indented then it is a continuation of the previous line and the two combined represent the entire Device Marking for that device.

(6) Lead finish/Ball material - Orderable Devices may have multiple material finish options. Finish options are separated by a vertical ruled line. Lead finish/Ball material values may wrap to two lines if the finish value exceeds the maximum column width.

Important Information and Disclaimer:The information provided on this page represents TI's knowledge and belief as of the date that it is provided. TI bases its knowledge and belief on information provided by third parties, and makes no representation or warranty as to the accuracy of such information. Efforts are underway to better integrate information from third parties. TI has taken and continues to take reasonable steps to provide representative and accurate information but may not have conducted destructive testing or chemical analysis on incoming materials and chemicals. TI and TI suppliers consider certain information to be proprietary, and thus CAS numbers and other limited information may not be available for release.

In no event shall TI's liability arising out of such information exceed the total purchase price of the TI part(s) at issue in this document sold by TI to Customer on an annual basis.

TAPE AND REEL INFORMATION

QUADRANT ASSIGNMENTS FOR PIN 1 ORIENTATION IN TAPE

*All dimensions are nominal

Device	Package Type	Package Drawing	Pins	SPQ	Reel Diameter (mm)	Reel Width W1 (mm)	A0 (mm)	B0 (mm)	K0 (mm)	P1 (mm)	W (mm)	Pin1 Quadrant
LM2756TM/NOPB	DSBGA	YFQ	20	250	178.0	8.4	1.89	2.2	0.76	4.0	8.0	Q1
LM2756TMX/NOPB	DSBGA	YFQ	20	3000	178.0	8.4	1.89	2.2	0.76	4.0	8.0	Q1

TAPE AND REEL BOX DIMENSIONS

*All dimensions are nominal

Device	Package Type	Package Drawing	Pins	SPQ	Length (mm)	Width (mm)	Height (mm)
LM2756TM/NOPB	DSBGA	YFQ	20	250	210.0	185.0	35.0
LM2756TMX/NOPB	DSBGA	YFQ	20	3000	210.0	185.0	35.0

YFQ0020

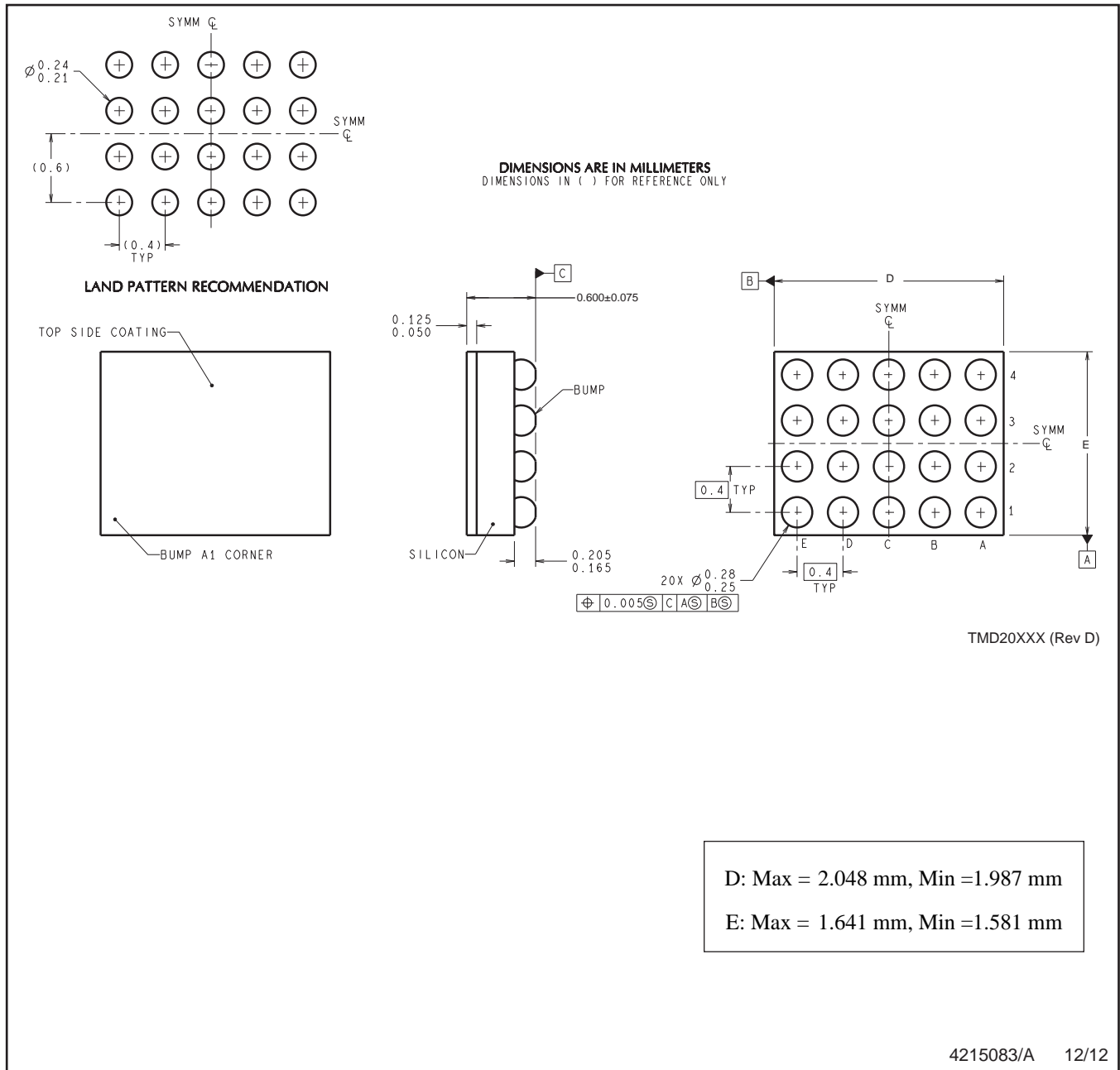

NOTES: A. All linear dimensions are in millimeters. Dimensioning and tolerancing per ASME Y14.5M-1994.
B. This drawing is subject to change without notice.

IMPORTANT NOTICE AND DISCLAIMER

TI PROVIDES TECHNICAL AND RELIABILITY DATA (INCLUDING DATA SHEETS), DESIGN RESOURCES (INCLUDING REFERENCE DESIGNS), APPLICATION OR OTHER DESIGN ADVICE, WEB TOOLS, SAFETY INFORMATION, AND OTHER RESOURCES "AS IS" AND WITH ALL FAULTS, AND DISCLAIMS ALL WARRANTIES, EXPRESS AND IMPLIED, INCLUDING WITHOUT LIMITATION ANY IMPLIED WARRANTIES OF MERCHANTABILITY, FITNESS FOR A PARTICULAR PURPOSE OR NON-INFRINGEMENT OF THIRD PARTY INTELLECTUAL PROPERTY RIGHTS.

These resources are intended for skilled developers designing with TI products. You are solely responsible for (1) selecting the appropriate TI products for your application, (2) designing, validating and testing your application, and (3) ensuring your application meets applicable standards, and any other safety, security, regulatory or other requirements.

These resources are subject to change without notice. TI grants you permission to use these resources only for development of an application that uses the TI products described in the resource. Other reproduction and display of these resources is prohibited. No license is granted to any other TI intellectual property right or to any third party intellectual property right. TI disclaims responsibility for, and you will fully indemnify TI and its representatives against, any claims, damages, costs, losses, and liabilities arising out of your use of these resources.

TI's products are provided subject to [TI's Terms of Sale](#) or other applicable terms available either on ti.com or provided in conjunction with such TI products. TI's provision of these resources does not expand or otherwise alter TI's applicable warranties or warranty disclaimers for TI products.

TI objects to and rejects any additional or different terms you may have proposed.

Mailing Address: Texas Instruments, Post Office Box 655303, Dallas, Texas 75265
Copyright © 2022, Texas Instruments Incorporated