

# LMR23630-Q1 SIMPLE SWITCHER® 36V、3A 同步降压转换器

## 1 特性

- 符合汽车应用 标准
- 具有符合 AEC-Q100 标准的下列特性：
  - 器件温度 1 级：-40°C 至 +125°C 的环境运行温度范围
  - 器件 HBM ESD 分类等级 2
  - 器件 CDM ESD 分类等级：
    - 带 RT 的 SOIC 和 WSON - C4B 级
    - 带 PGOOD 的 WSON - C5 级
- 4V 至 36V 的输入范围
- 3A 持续输出电流
- 最短导通时间：60ns
- 内置补偿功能，便于使用
- 400kHz 固定开关频率和可调开关频率两种选择
- 在轻负载条件下，有脉频调制 (PFM) 和强制脉宽调制 (PWM) 两种模式可供选项
- 与外部时钟频率同步
- 对于 PFM 选项，无负载条件下的静态电流为 75µA
- 电源正常选项
- 软启动至预偏置负载
- 支持高占空比运行模式
- 具有间断模式的输出短路保护
- 8 引脚 HSOIC 和 12 引脚 WSON 可湿侧面，具有 PowerPAD™ 封装选项
- 结合使用 LMR23630-Q1 和 WEBENCH® 电源设计器创建定制设计

## 2 应用

- 汽车信息娱乐系统：仪表组、音响主机、抬头显示
- USB 充电
- 一般电池供电 应用

## 3 说明

LMR23630-Q1 SIMPLE SWITCHER® 是一款简便易用的 36V、3A 同步降压稳压器。该器件具有 4V 至 36V 的宽输入范围，适用于从工业到汽车各类应用中非稳压电源的电压调节。采用峰值电流模式控制来实现简单控制环路补偿和逐周期电流限制。其静态电流低至 75µA，因此适用于电池供电类系统。内部环路补偿意味着用户不用承担设计环路补偿组件的枯燥工作。这样还能够最大限度地减少外部元件数。该器件还具有恒定频率 FPWM 模式，可在轻载时实现较小的输出电压纹波。该器件的扩展系列产品能够以引脚到引脚兼容的封装提供 1A (LMR23610-Q1)、1.5A (LMR23615-Q1) 和 2.5A (LMR23625-Q1) 负载电流选项，从而可以实现简单且最佳的 PCB 布局。利用精密使能端输入可以简化稳压器控制和系统电源定序。保护特性包括逐周期电流限制、间断模式短路保护和过多功率耗散而引起的热关断。

### 器件信息(1)

器件型号	封装	封装尺寸 (标称值)
LMR23630-Q1	HSOIC (8)	4.90mm x 3.90mm
	WSON (12)	3.00mm x 3.00mm

(1) 要了解所有不同可用选项的详细部件号，请参见数据表末尾的可订购产品附录。

### 简化原理图

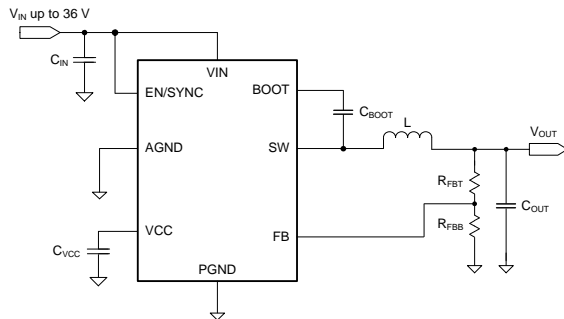

### 效率与负载间的关系，VIN = 12V，PFM 选项

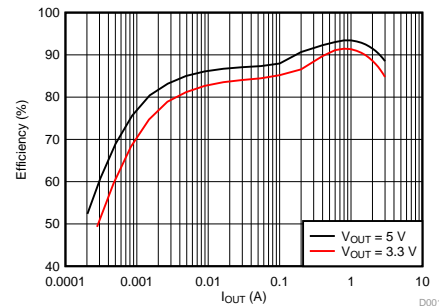

## 目录

1	特性 .....	1	8.3	Feature Description .....	11
2	应用 .....	1	8.4	Device Functional Modes .....	18
3	说明 .....	1	<b>9</b>	<b>Application and Implementation .....</b>	<b>19</b>
4	修订历史记录 .....	2	9.1	Application Information .....	19
5	<b>Product Portfolio .....</b>	<b>3</b>	9.2	Typical Applications .....	19
6	<b>Pin Configuration and Functions .....</b>	<b>3</b>	<b>10</b>	<b>Power Supply Recommendations .....</b>	<b>26</b>
7	<b>Specifications .....</b>	<b>4</b>	<b>11</b>	<b>Layout .....</b>	<b>26</b>
7.1	Absolute Maximum Ratings .....	4	11.1	Layout Guidelines .....	26
7.2	ESD Ratings .....	4	11.2	Layout Examples .....	28
7.3	Recommended Operating Conditions .....	4	<b>12</b>	<b>器件和文档支持 .....</b>	<b>29</b>
7.4	Thermal Information .....	5	12.1	使用 WEBENCH® 工具创建定制设计 .....	29
7.5	Electrical Characteristics .....	5	12.2	接收文档更新通知 .....	29
7.6	Timing Characteristics .....	6	12.3	社区资源 .....	29
7.7	Switching Characteristics .....	7	12.4	商标 .....	29
7.8	Typical Characteristics .....	8	12.5	静电放电警告 .....	29
<b>8</b>	<b>Detailed Description .....</b>	<b>10</b>	12.6	Glossary .....	29
8.1	Overview .....	10	<b>13</b>	<b>机械、封装和可订购信息 .....</b>	<b>29</b>
8.2	Functional Block Diagram .....	10			

## 4 修订历史记录

注：之前版本的页码可能与当前版本有所不同。

Changes from Revision A (April 2017) to Revision B	Page
• 在 12 引脚 WSON 中添加了“可湿”一词 .....	1
• 删除了“汽车电池稳压、工业电源、电信和数据通信系统”并修改了“应用”中的措辞 .....	1
• 已删除 针对市场发布从 WSON 内容中删除了“预览”；对格式进行了编辑性更新 .....	1
• Updating the the drawing title for Pin Configurations and Functions for WSON with RT and WSON with PGOOD .....	3
• Corrected the column title for WSON with RT and WSON with PGOOD .....	3
• Updating the ESD Ratings to include both SOIC and WSON packages .....	4
• Changing from EN Pin to EN/SYNC Pin .....	5
• Added WSON only on the <i>Electrical Characteristic</i> table for PGOOD .....	5
• Changing the minimum value for $V_{PG\_OV}$ from 105% to 104% .....	5
• Adding a row for WSON Peak and Valley inductor current limit .....	6
• Changed the min and max for minimum adjustable frequency from 180kHz and 220kHz to 150kHz and 250kHz .....	7
• Changed the min,typ, and max values for maximum adjustable frequency from 1980kHz,2200kHz, and 2420kHz to 1750kHz,2150kHz and 2425kHz .....	7

Changes from Original (December 2016) to Revision A	Page
• Changed the ESD HBM rating to $\pm 2000$ from $\pm 2500$ .....	4

## 5 Product Portfolio

PACKAGE	PART NUMBER	FIXED 400 kHz	ADJUSTABLE FREQUENCY	POWER GOOD	FPWM
SOIC (8)	LMR23630AQDDARQ1	Yes	No	No	No
	LMR23630AFQDDARQ1	Yes	No	No	Yes
WSO (12) (Pin 6 is RT)	LMR23630QDRRRQ1	No	Yes	No	No
	LMR23630FQDRRRQ1	No	Yes	No	Yes
WSO (12) (Pin 6 is PGOOD)	LMR23630APQDRRRQ1	Yes	No	Yes	No

## 6 Pin Configuration and Functions

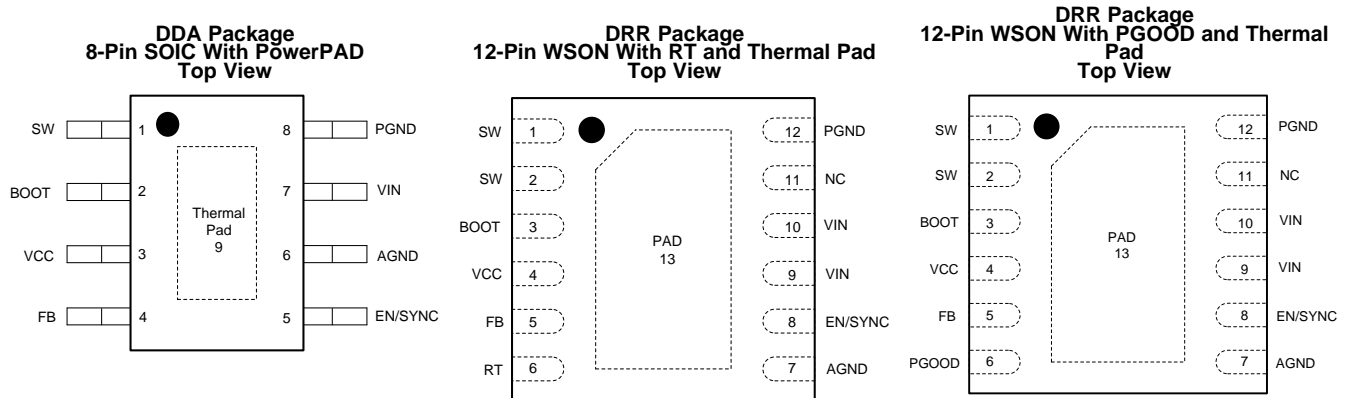

### Pin Functions

NAME	PIN			I/O <sup>(1)</sup>	DESCRIPTION
	SOIC	WSO With PGOOD	WSO With RT		
SW	1	1, 2	1, 2	P	Switching output of the regulator. Internally connected to both power MOSFETs. Connect to power inductor.
BOOT	2	3	3	P	Boot-strap capacitor connection for high-side driver. Connect a high-quality, 100-nF capacitor from BOOT to SW.
VCC	3	4	4	P	Internal bias supply output for bypassing. Connect a 2.2- $\mu$ F, 16-V or higher capacitance bypass capacitor from this pin to AGND. Do not connect external loading to this pin. Never short this pin to ground during operation.
FB	4	5	5	A	Feedback input to regulator, connect the midpoint of feedback resistor divider to this pin.
RT	N/A	N/A	6	A	Connect a resistor $R_T$ from this pin to AGND to program switching frequency. Leave floating for 400-kHz default switching frequency.
PGOOD	N/A	6	N/A	A	Open drain output for power-good flag. Use a 10-k $\Omega$ to 100-k $\Omega$ pullup resistor to logic rail or other DC voltage no higher than 12 V.
EN/SYNC	5	8	8	A	Enable input to regulator. High = On, Low = Off. Can be connected to VIN. Do not float. Adjust the input undervoltage lockout with two resistors. The internal oscillator can be synchronized to an external clock by coupling a positive pulse into this pin through a small coupling capacitor. See <a href="#">Enable/Synchronization</a> for details.
AGND	6	7	7	G	Analog ground pin. Ground reference for internal references and logic. Connect to system ground.
VIN	7	9, 10	9, 10	P	Input supply voltage.
PGND	8	12	12	G	Power ground pin, connected internally to the low side power FET. Connect to system ground, PAD, AGND, ground pins of $C_{IN}$ and $C_{OUT}$ . Path to $C_{IN}$ must be as short as possible.
PAD	9	13	13	G	Low impedance connection to AGND. Connect to PGND on PCB. Major heat dissipation path of the die. Must be used for heat sinking to ground plane on PCB.
NC	N/A	11	11	N/A	Not for use. Leave this pin floating.

(1) A = Analog, P = Power, G = Ground.

## 7 Specifications

### 7.1 Absolute Maximum Ratings

Over the recommended operating junction temperature range of  $-40^{\circ}\text{C}$  to  $+125^{\circ}\text{C}$  (unless otherwise noted)<sup>(1)</sup>

PARAMETER		MIN	MAX	UNIT
Input voltages	VIN to PGND	-0.3	42	V
	EN/SYNC to AGND	-5.5	$V_{IN} + 0.3$	
	FB to AGND	-0.3	4.5	
	RT to AGND	-0.3	4.5	
	PGOOD to AGND	-0.3	15	
	AGND to PGND	-0.3	0.3	
Output voltages	SW to PGND	-1	$V_{IN} + 0.3$	V
	SW to PGND less than 10-ns transients	-5	42	
	BOOT to SW	-0.3	5.5	
	VCC to AGND	-0.3	4.5 <sup>(2)</sup>	
Junction temperature, $T_J$		-40	150	$^{\circ}\text{C}$
Storage temperature, $T_{stg}$		-65	150	$^{\circ}\text{C}$

- (1) Stresses beyond those listed under *Absolute Maximum Ratings* may cause permanent damage to the device. These are stress ratings only, which do not imply functional operation of the device at these or any other conditions beyond those indicated under *Recommended Operating Conditions*. Exposure to absolute-maximum-rated conditions for extended periods may affect device reliability.
- (2) In shutdown mode, the VCC to AGND maximum value is 5.25 V.

### 7.2 ESD Ratings

		VALUE	UNIT
$V_{(ESD)}$ Electrostatic discharge	Human-body model (HBM) for SOIC <sup>(1)</sup>	$\pm 2000$	V
	Human-body model (HBM) for WSON with RT or PGOOD	$\pm 2500$	
	Charged-device model (CDM) for SOIC	$\pm 1000$	
	Charged-device model (CDM) for WSON with RT	$\pm 1000$	
	Charged-device model (CDM) for WSON with PGOOD	$\pm 750$	

- (1) AEC Q100-002 indicates that HBM stressing shall be in accordance with the ANSI/ESDA/JEDEC JS-001 specification.

### 7.3 Recommended Operating Conditions

Over the recommended operating junction temperature range of  $-40^{\circ}\text{C}$  to  $+125^{\circ}\text{C}$  (unless otherwise noted)<sup>(1)</sup>

		MIN	MAX	UNIT
Input voltage	VIN	4	36	V
	EN/SYNC	-5	36	
	FB	-0.3	1.2	
	PGOOD	-0.3	12	
Input current	PGOOD pin current	0	1	mA
Output voltage, $V_{OUT}$		1	28	V
Output current, $I_{OUT}$		0	3	A
Operating junction temperature, $T_J$		-40	125	$^{\circ}\text{C}$

- (1) Recommended Operating Ratings indicate conditions for which the device is intended to be functional, but do not ensure specific performance limits. For specified specifications, see [Electrical Characteristics](#).

## 7.4 Thermal Information

THERMAL METRIC <sup>(1)(2)</sup>		LMR23630-Q1		UNIT
		DDA (SOIC)	DRR (WSON)	
		8 PINS	12 PINS	
R <sub>θJA</sub>	Junction-to-ambient thermal resistance	42.0	41.5	°C/W
R <sub>θJC(top)</sub>	Junction-to-case (top) thermal resistance	5.9	0.3	°C/W
R <sub>θJB</sub>	Junction-to-board thermal resistance	23.4	16.5	°C/W
ψ <sub>JT</sub>	Junction-to-top characterization parameter	45.8	39.1	°C/W
ψ <sub>JB</sub>	Junction-to-board characterization parameter	3.6	3.4	°C/W
R <sub>θJC(bot)</sub>	Junction-to-case (bottom) thermal resistance	23.4	16.3	°C/W

- (1) For more information about traditional and new thermal metrics, see the [Semiconductor and IC Package Thermal Metrics](#) application report.
- (2) Determine power rating at a specific ambient temperature T<sub>A</sub> with a maximum junction temperature (T<sub>J</sub>) of 125°C, which is illustrated in [Recommended Operating Conditions](#) section.

## 7.5 Electrical Characteristics

Limits apply over the recommended operating junction temperature (T<sub>J</sub>) range of –40°C to +125°C, unless otherwise stated. Minimum and Maximum limits are specified through test, design or statistical correlation. Typical values represent the most likely parametric norm at T<sub>J</sub> = 25°C, and are provided for reference purposes only.

PARAMETER		TEST CONDITIONS	MIN	TYP	MAX	UNIT
<b>POWER SUPPLY (VIN PIN)</b>						
V <sub>IN</sub>	Operation input voltage		4		36	V
VIN_UVLO	Undervoltage lockout thresholds	Rising threshold	3.3	3.7	3.9	V
		Falling threshold	2.9	3.3	3.5	
I <sub>SHDN</sub>	Shutdown supply current	V <sub>EN</sub> = 0 V, V <sub>IN</sub> = 12 V, T <sub>J</sub> = –40°C to 125°C		2	4	μA
I <sub>Q</sub>	Operating quiescent current (non-switching)	V <sub>IN</sub> = 12 V, V <sub>FB</sub> = 1.1 V, T <sub>J</sub> = –40°C to 125°C, PFM mode		75		μA
<b>ENABLE (EN/SYNC PIN)</b>						
V <sub>EN_H</sub>	Enable rising threshold voltage		1.4	1.55	1.7	V
V <sub>EN_HYS</sub>	Enable hysteresis voltage			0.4		V
V <sub>WAKE</sub>	Wake-up threshold		0.4			V
I <sub>EN</sub>	Input leakage current at EN pin	V <sub>IN</sub> = 4 V to 36 V, V <sub>EN</sub> = 2 V		10	100	nA
		V <sub>IN</sub> = 4 V to 36 V, V <sub>EN</sub> = 36 V			1	μA
<b>VOLTAGE REFERENCE (FB PIN)</b>						
V <sub>REF</sub>	Reference voltage	V <sub>IN</sub> = 4 V to 36 V, T <sub>J</sub> = 25°C	0.985	1	1.015	V
		V <sub>IN</sub> = 4 V to 36 V, T <sub>J</sub> = –40°C to 125°C	0.98	1	1.02	
I <sub>LKG_FB</sub>	Input leakage current at FB pin	V <sub>FB</sub> = 1 V		10		nA
<b>POWER GOOD (PGOOD PIN) WSON Only</b>						
V <sub>PG_OV</sub>	Power-good flag overvoltage tripping threshold	% of reference voltage	104%	107%	110%	
V <sub>PG_UV</sub>	Power-good flag undervoltage tripping threshold	% of reference voltage	92%	94%	96.5%	
V <sub>PG_HYS</sub>	Power-good flag recovery hysteresis	% of reference voltage		1.5%		
V <sub>IN_PG_MIN</sub>	Minimum VIN for valid PGOOD output	50 μA pullup to PGOOD pin, V <sub>EN</sub> = 0 V, T <sub>J</sub> = 25°C			1.5	V
V <sub>PG_LOW</sub>	PGOOD low level output voltage	50 μA pullup to PGOOD pin, V <sub>IN</sub> = 1.5 V, V <sub>EN</sub> = 0 V			0.4	V
		0.5 mA pullup to PGOOD pin, V = 13.5 V, V <sub>EN</sub> = 0 V			0.4	

## Electrical Characteristics (continued)

Limits apply over the recommended operating junction temperature ( $T_J$ ) range of  $-40^{\circ}\text{C}$  to  $+125^{\circ}\text{C}$ , unless otherwise stated. Minimum and Maximum limits are specified through test, design or statistical correlation. Typical values represent the most likely parametric norm at  $T_J = 25^{\circ}\text{C}$ , and are provided for reference purposes only.

PARAMETER		TEST CONDITIONS	MIN	TYP	MAX	UNIT
<b>INTERNAL LDO (VCC PIN)</b>						
$V_{CC}$	Internal LDO output voltage			4.1		V
$V_{CC\_UVLO}$	VCC undervoltage lockout thresholds	Rising threshold	2.8	3.2	3.6	V
		Falling threshold	2.4	2.8	3.2	
<b>CURRENT LIMIT</b>						
$I_{HS\_LIMIT}$	Peak inductor current limit	HSOIC package	3.8	5	6.2	A
		WSO package	4	5.5	6.6	
$I_{LS\_LIMIT}$	Valley inductor current limit	HSOIC package	2.9	3.6	4.6	A
		WSO package	2.9	3.6	4.2	
$I_{L\_ZC}$	Zero cross current limit		-0.04			A
$I_{L\_NEG}$	Negative current limit (FPWM option)		-2.7	-2	-1.3	A
<b>INTEGRATED MOSFETS</b>						
$R_{DS\_ON\_HS}$	High-side MOSFET ON-resistance	HSOIC package, $V_{IN} = 12\text{ V}$ , $I_{OUT} = 1\text{ A}$		185		m $\Omega$
		WSO package, $V_{IN} = 12\text{ V}$ , $I_{OUT} = 1\text{ A}$		160		
$R_{DS\_ON\_LS}$	Low-side MOSFET ON-resistance	HSOIC package, $V_{IN} = 12\text{ V}$ , $I_{OUT} = 1\text{ A}$		105		m $\Omega$
		WSO package, $V_{IN} = 12\text{ V}$ , $I_{OUT} = 1\text{ A}$		95		
<b>THERMAL SHUTDOWN</b>						
$T_{SHDN}$	Thermal shutdown threshold		162	170	178	$^{\circ}\text{C}$
$T_{HYS}$	Hysteresis			15		$^{\circ}\text{C}$

## 7.6 Timing Characteristics

Over the recommended operating junction temperature range of  $-40^{\circ}\text{C}$  to  $+125^{\circ}\text{C}$  (unless otherwise noted)

			MIN	NOM	MAX	UNIT
<b>HICCUP MODE</b>						
$N_{OC}^{(1)}$	Number of cycles that LS current limit is tripped to enter Hiccup mode			64		Cycle s
$T_{OC}$	Hiccup retry delay time	SOIC package		5		ms
		WSO package		10		
<b>SOFT START</b>						
$T_{SS}$	Internal soft-start time. The time of internal reference to increase from 0 V to 1 V	SOIC package	1	2	3	ms
		WSO package		6		
<b>POWER GOOD</b>						
$T_{PGOOD\_RISE}$	Power-good flag rising transition deglitch delay			150		$\mu\text{s}$
$T_{PGOOD\_FALL}$	Power-good flag falling transition deglitch delay			18		$\mu\text{s}$

(1) Specified by design.

## 7.7 Switching Characteristics

Over the recommended operating junction temperature range of  $-40^{\circ}\text{C}$  to  $+125^{\circ}\text{C}$  (unless otherwise noted)

PARAMETER		TEST CONDITION	MIN	TYP	MAX	UNIT
<b>SW (SW PIN)</b>						
$T_{\text{ON\_MIN}}$	Minimum turnon time			60	90	ns
$T_{\text{OFF\_MIN}}^{(1)}$	Minimum turnoff time			100		ns
<b>OSCILLATOR (RT and EN/SYNC PIN)</b>						
$f_{\text{SW\_DEFAULT}}$	Oscillator default frequency	Fixed frequency option or RT pin open circuit	340	400	460	kHz
$f_{\text{ADJ}}$	Minimum adjustable frequency	$R_T = 198\text{ k}\Omega$ with 1% accuracy	150	200	250	kHz
	Maximum adjustable frequency	$R_T = 17.8\text{ k}\Omega$ with 1% accuracy	1750	2150	2425	kHz
$f_{\text{SYNC}}$	SYNC frequency range		200		2200	kHz
$V_{\text{SYNC}}$	Amplitude of SYNC clock AC signal (measured at SYNC pin)		2.8		5.5	V
$T_{\text{SYNC\_MIN}}$	Minimum sync clock ON- and OFF-time			100		ns

(1) Specified by design.

### 7.8 Typical Characteristics

Unless otherwise specified the following conditions apply:  $V_{IN} = 12\text{ V}$ ,  $f_{SW} = 400\text{ kHz}$ ,  $L = 8.2\text{ }\mu\text{H}$ ,  $C_{OUT} = 150\text{ }\mu\text{F}$ ,  $T_A = 25^\circ\text{C}$ .

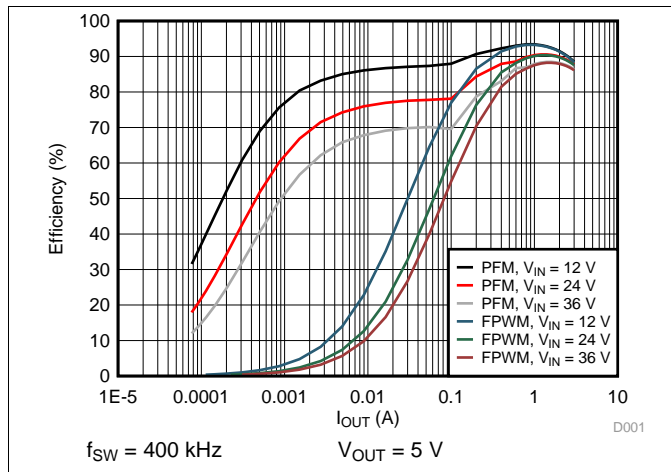

Figure 1. Efficiency vs Load Current

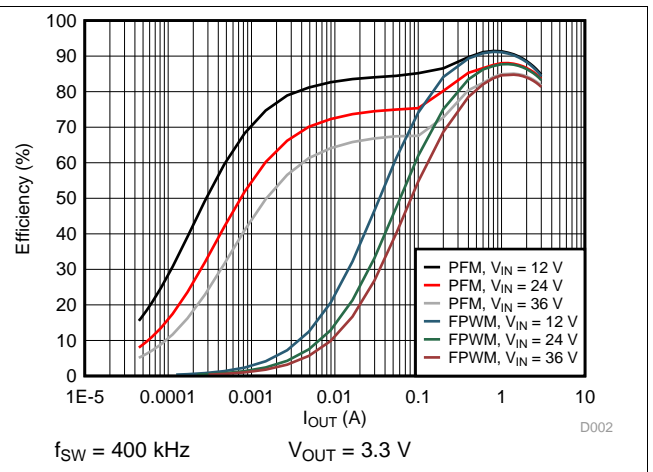

Figure 2. Efficiency vs Load Current

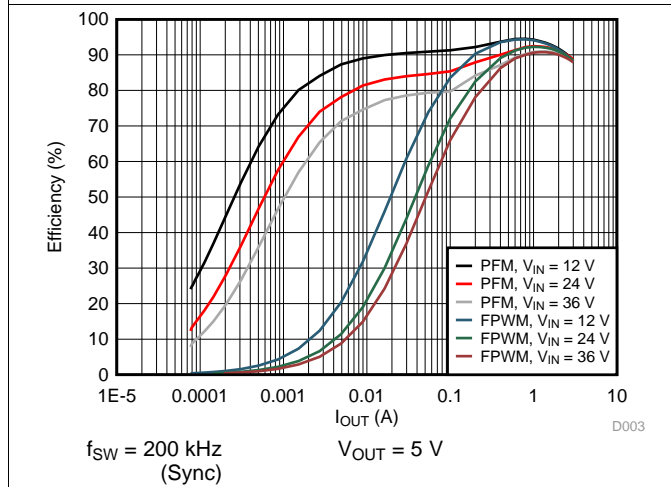

Figure 3. Efficiency vs Load Current

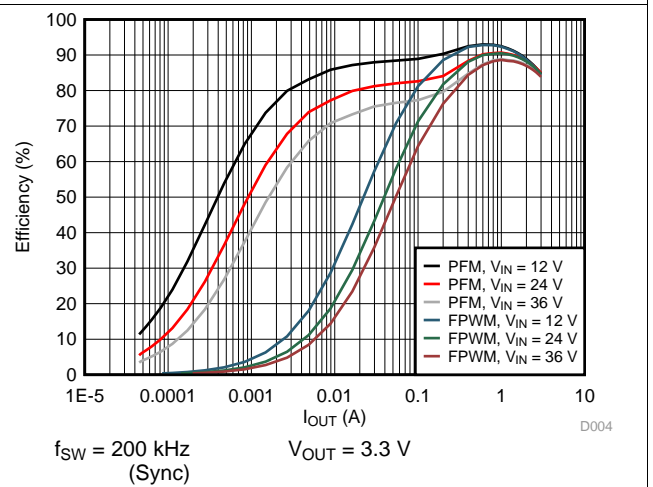

Figure 4. Efficiency vs Load Current

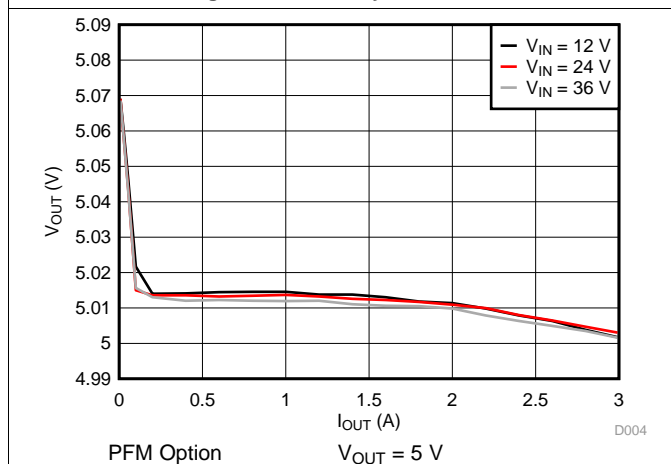

Figure 5. Load Regulation

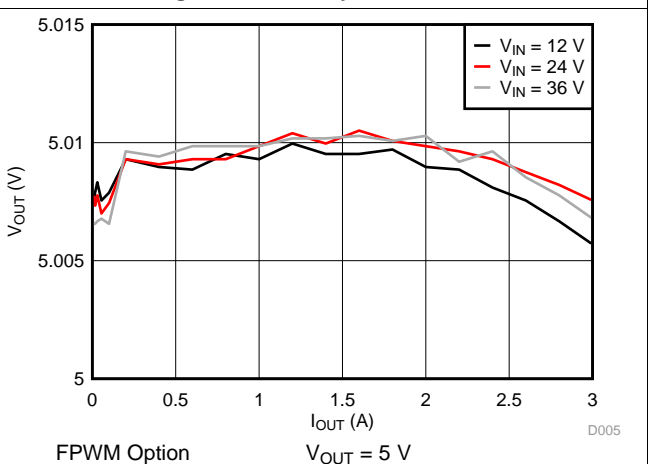

Figure 6. Load Regulation



Typical Characteristics (continued)

Unless otherwise specified the following conditions apply:  $V_{IN} = 12\text{ V}$ ,  $f_{SW} = 400\text{ kHz}$ ,  $L = 8.2\text{ }\mu\text{H}$ ,  $C_{OUT} = 150\text{ }\mu\text{F}$ ,  $T_A = 25^\circ\text{C}$ .

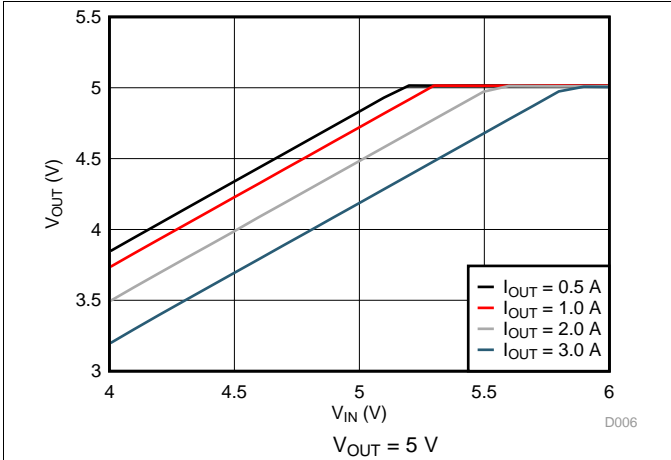

Figure 7. Dropout Curve

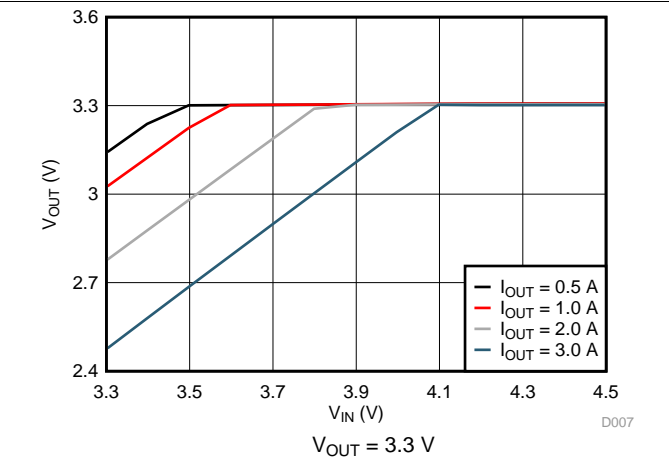

Figure 8. Dropout Curve

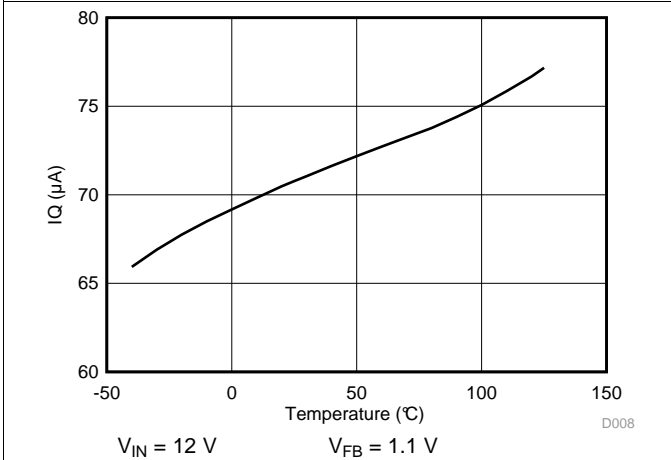

Figure 9.  $I_Q$  vs Junction Temperature

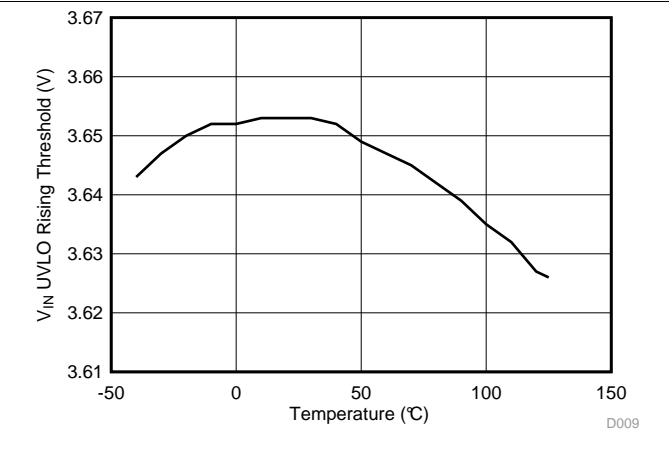

Figure 10.  $V_{IN}$  UVLO Rising Threshold vs Junction Temperature

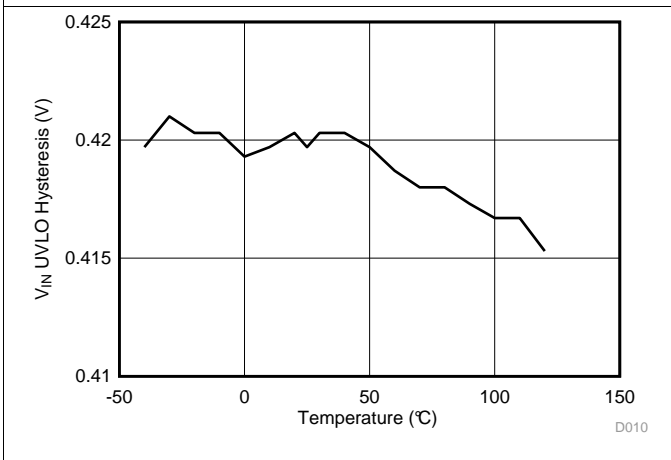

Figure 11.  $V_{IN}$  UVLO Hysteresis vs Junction Temperature

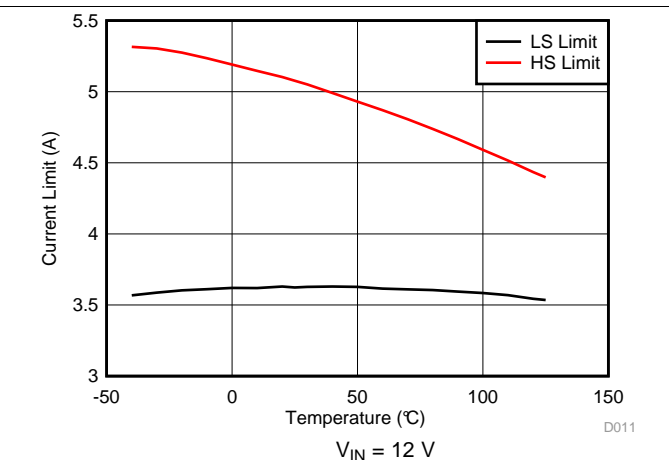

Figure 12. HS and LS Current Limit vs Junction Temperature

## 8 Detailed Description

### 8.1 Overview

The LMR23630-Q1 SIMPLE SWITCHER® regulator is an easy-to-use synchronous step-down DC/DC converter operating from 4-V to 36-V supply voltage. The device is capable of delivering up to 3-A DC load current with good thermal performance in a small solution size. For both SOIC and WSON packages, an extended family is available in multiple current options from 1-A to 3-A in pin-to-pin compatible packages.

The LMR23630-Q1 employs constant-frequency peak-current-mode control. The device enters PFM mode at light load to achieve high efficiency. A user-selectable FPWM option is provided to achieve low output voltage ripple, tight output voltage regulation, and constant switching frequency. The device is internally compensated, which reduces design time and requires few external components. The switching frequency is fixed 400 kHz. For the option which has an RT pin, the switching frequency is adjustable from 200 kHz to 2.2 MHz. Also, the LMR23630-Q1 is capable of synchronization to an external clock within the range of 200 kHz to 2.2 MHz.

Additional features such as precision enable, power-good flag, and internal soft start provide a flexible and easy-to-use solution for a wide range of applications. Protection features include thermal shutdown, VIN and VCC undervoltage lockout, cycle-by-cycle current limit, and hiccup-mode short-circuit protection.

The family requires very few external components and has a pinout designed for simple, optimum PCB layout.

### 8.2 Functional Block Diagram

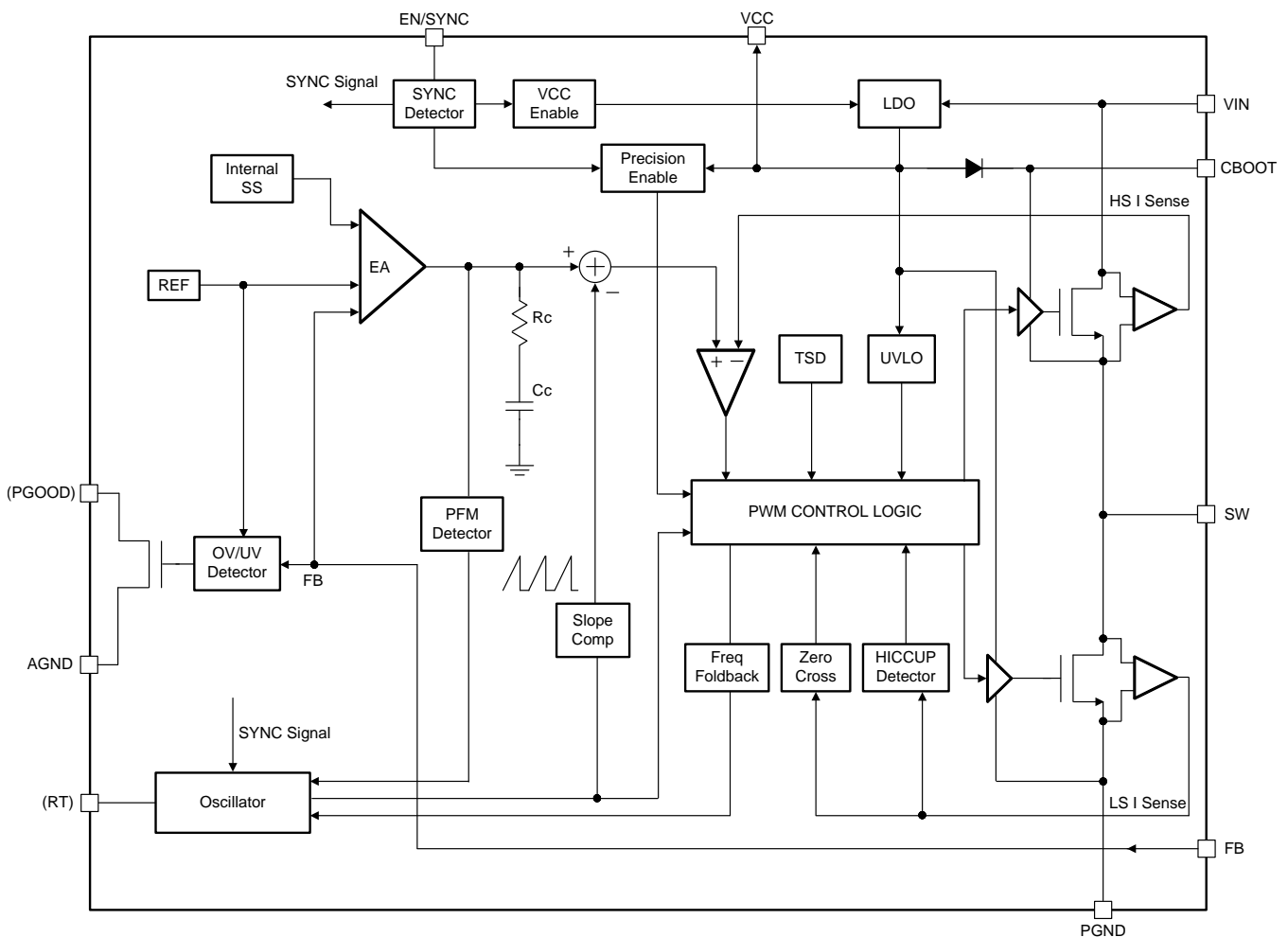

Copyright © 2016, Texas Instruments Incorporated

## 8.3 Feature Description

### 8.3.1 Fixed-Frequency Peak-Current-Mode Control

The following operating description of the LMR23630-Q1 refers to the [Functional Block Diagram](#) and to the waveforms in [Figure 13](#). LMR23630-Q1 is a step-down synchronous buck regulator with integrated high-side (HS) and low-side (LS) switches (synchronous rectifier). The LMR23630-Q1 supplies a regulated output voltage by turning on the HS and LS NMOS switches with controlled duty cycle. During high-side switch ON-time, the SW pin voltage swings up to approximately  $V_{IN}$ , and the inductor current  $i_L$  increase with linear slope  $(V_{IN} - V_{OUT}) / L$ . When the HS switch is turned off by the control logic, the LS switch is turned on after an anti-shoot-through dead time. Inductor current discharges through the LS switch with a slope of  $-V_{OUT} / L$ . The control parameter of a buck converter is defined as duty cycle  $D = t_{ON} / T_{SW}$ , where  $t_{ON}$  is the high-side switch ON-time and  $T_{SW}$  is the switching period. The regulator control loop maintains a constant output voltage by adjusting the duty cycle  $D$ . In an ideal buck converter, where losses are ignored,  $D$  is proportional to the output voltage and inversely proportional to the input voltage:  $D = V_{OUT} / V_{IN}$ .

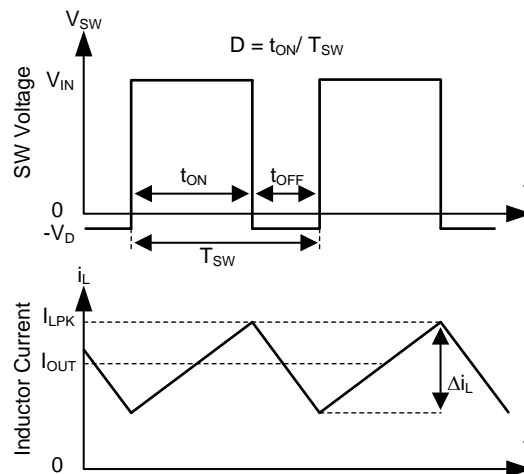

**Figure 13. SW Node and Inductor Current Waveforms in Continuous Conduction Mode (CCM)**

The LMR23630-Q1 employs fixed-frequency peak-current-mode control. A voltage feedback loop is used to get accurate DC voltage regulation by adjusting the peak current command based on voltage offset. The peak inductor current is sensed from the high-side switch and compared to the peak current threshold to control the ON time of the high-side switch. The voltage feedback loop is internally compensated, which allows for fewer external components, makes it easy to design, and provides stable operation with almost any combination of output capacitors. The regulator operates with fixed switching frequency at normal load condition. At light load condition, the LMR23630-Q1 operates in PFM mode to maintain high efficiency (PFM option) or in FPWM mode for low output voltage ripple, tight output voltage regulation, and constant switching frequency (FPWM option).

### 8.3.2 Adjustable Frequency

For adjustable switching frequency option of LMR23630-Q1. The switching frequency can be programmed by the impedance  $R_T$  from the RT pin to ground. The frequency is inversely proportional to the  $R_T$  resistance. The RT pin can be left floating, and the LMR23630-Q1 will operate at 400-kHz default switching frequency. The RT pin is not designed to be shorted to ground. For a desired frequency, typical  $R_T$  resistance can be found by [Equation 1](#). [Table 1](#) gives typical  $R_T$  values for a given  $f_{SW}$ .

$$R_T(\text{k}\Omega) = 40200 / f_{SW}(\text{kHz}) - 0.6 \quad (1)$$

Feature Description (continued)

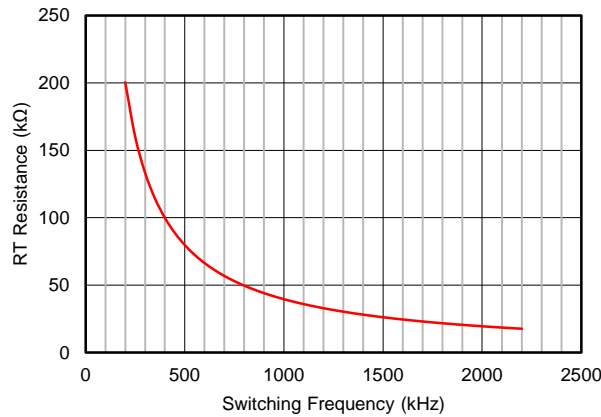

Figure 14. RT vs Frequency Curve

Table 1. Typical Frequency Setting RT Resistance

f <sub>sw</sub> (kHz)	R <sub>T</sub> (kΩ)
200	200
350	115
500	78.7
750	53.6
1000	39.2
1500	26.1
2000	19.6
2200	17.8

8.3.3 Adjustable Output Voltage

A precision 1-V reference voltage is used to maintain a tightly regulated output voltage over the entire operating temperature range. The output voltage is set by a resistor divider from output voltage to the FB pin. TI recommends using 1% tolerance resistors with a low temperature coefficient for the FB divider. Select the low-side resistor R<sub>FBB</sub> for the desired divider current and use Equation 2 to calculate high-side R<sub>FBT</sub>. R<sub>FBT</sub> in the range from 10 kΩ to 100 kΩ is recommended for most applications. A lower R<sub>FBT</sub> value can be used if static loading is desired to reduce V<sub>OUT</sub> offset in PFM operation. Lower R<sub>FBT</sub> reduces efficiency at very light load. Less static current goes through a larger R<sub>FBT</sub> and might be more desirable when light load efficiency is critical. But R<sub>FBT</sub> larger than 1 MΩ is not recommended because it makes the feedback path more susceptible to noise. Larger R<sub>FBT</sub> value requires more carefully designed feedback path on the PCB. The tolerance and temperature variation of the resistor dividers affect the output voltage regulation.

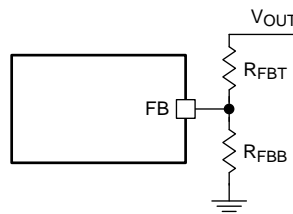

Figure 15. Output Voltage Setting

$$R_{FBT} = \frac{V_{OUT} - V_{REF}}{V_{REF}} \times R_{FBB} \tag{2}$$

### 8.3.4 Enable/Synchronization

The voltage on the EN pin controls the ON or OFF operation of LMR23630-Q1. A voltage less than 1 V (typical) shuts the device down while a voltage higher than 1.6 V (typical) is required to start the regulator. The EN/SYNC pin is an input and cannot be left open or floating. The simplest way to enable the operation of the LMR23630-Q1 is to connect the EN to  $V_{IN}$ . This allows self-start-up of the LMR23630-Q1 when  $V_{IN}$  is within the operation range.

Many applications benefit from the employment of an enable divider  $R_{ENT}$  and  $R_{ENB}$  (Figure 16) to establish a precision system UVLO level for the converter. System UVLO can be used for supplies operating from utility power as well as battery power. It can be used for sequencing, ensuring reliable operation, or supply protection, such as a battery discharge level. An external logic signal can also be used to drive EN input for system sequencing and protection.

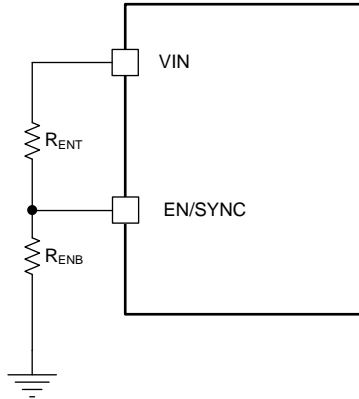

Figure 16. System UVLO by Enable Divider

The EN pin also can be used to synchronize the internal oscillator to an external clock. The internal oscillator can be synchronized by AC coupling a positive edge into the EN pin. The AC coupled peak-to-peak voltage at the EN pin must exceed the SYNC amplitude threshold of 2.8 V (typical) to trip the internal synchronization pulse detector, and the minimum SYNC clock ON and OFF time must be longer than 100ns (typ). A 3.3 V or a higher amplitude pulse signal coupled through a 1 nF capacitor  $C_{SYNC}$  is a good starting point. Keeping  $R_{ENT} // R_{ENB}$  ( $R_{ENT}$  parallel with  $R_{ENB}$ ) in the 100-k $\Omega$  range is a good choice.  $R_{ENT}$  is required for this synchronization circuit, but  $R_{ENB}$  can be left unmounted if system UVLO is not needed. LMR23630-Q1 switching action can be synchronized to an external clock from 200 kHz to 2.2 MHz. Figure 18 and Figure 19 show the device synchronized to an external system clock.

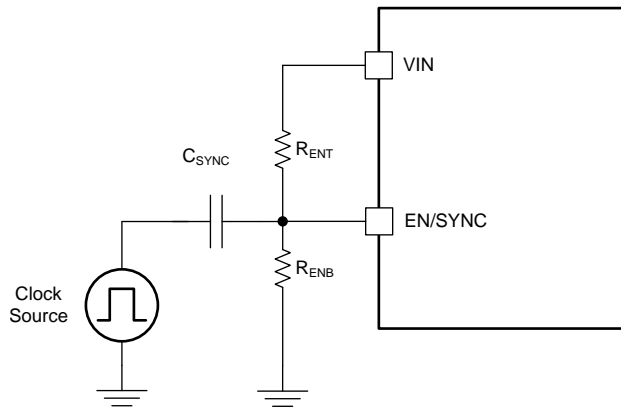

Figure 17. Synchronize to External Clock

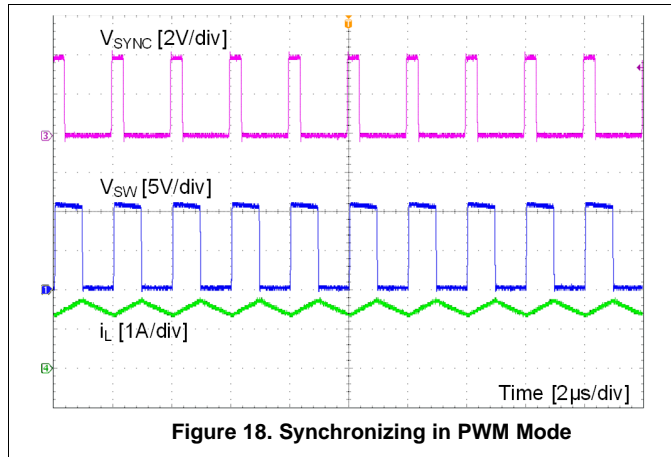

Figure 18. Synchronizing in PWM Mode

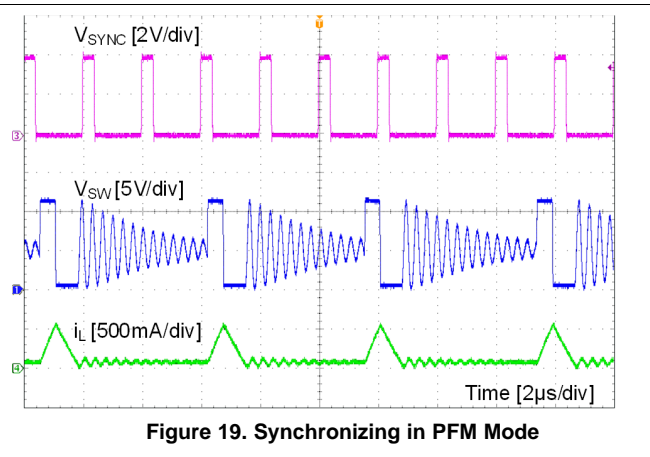

Figure 19. Synchronizing in PFM Mode

### 8.3.5 V<sub>CC</sub>, UVLO

The LMR23630-Q1 integrates an internal LDO to generate  $V_{CC}$  for control circuitry and MOSFET drivers. The nominal voltage for  $V_{CC}$  is 4.1 V. The  $V_{CC}$  pin is the output of an LDO and must be properly bypassed. Place a high-quality ceramic capacitor with a value of 2.2  $\mu\text{F}$  to 10  $\mu\text{F}$ , 16 V or higher rated voltage as close as possible to  $V_{CC}$  and grounded to the exposed PAD and ground pins. Do not load the  $V_{CC}$  output pin or short to ground during operation. Shorting  $V_{CC}$  to ground during operation may cause damage to the LMR23630-Q1.

$V_{CC}$  undervoltage lockout (UVLO) prevents the LMR23630-Q1 from operating until the  $V_{CC}$  voltage exceeds 3.2 V (typical). The  $V_{CC}$  UVLO threshold has 400 mV (typical) of hysteresis to prevent undesired shutdown due to temporary  $V_{IN}$  drops.

### 8.3.6 Minimum ON-time, Minimum OFF-time and Frequency Foldback at Dropout Conditions

Minimum ON-time,  $T_{ON\_MIN}$ , is the smallest duration of time that the HS switch can be on.  $T_{ON\_MIN}$  is typically 60 ns in the LMR23630-Q1. Minimum OFF-time,  $T_{OFF\_MIN}$ , is the smallest duration that the HS switch can be off.  $T_{OFF\_MIN}$  is typically 100 ns in the LMR23630-Q1. In CCM operation,  $T_{ON\_MIN}$  and  $T_{OFF\_MIN}$  limit the voltage conversion range given a selected switching frequency.

The minimum duty cycle allowed is:

$$D_{MIN} = T_{ON\_MIN} \times f_{SW} \quad (3)$$

And the maximum duty cycle allowed is:

$$D_{MAX} = 1 - T_{OFF\_MIN} \times f_{SW} \quad (4)$$

Given fixed  $T_{ON\_MIN}$  and  $T_{OFF\_MIN}$ , the higher the switching frequency the narrower the range of the allowed duty cycle. In the LMR23630-Q1, a frequency foldback scheme is employed to extend the maximum duty cycle when  $T_{OFF\_MIN}$  is reached. The switching frequency decreases once longer duty cycle is needed under low  $V_{IN}$  conditions. Wide range of frequency foldback allows the LMR23630-Q1 output voltage stay in regulation with a much lower supply voltage  $V_{IN}$ . This leads to a lower effective dropout voltage.

Given an output voltage, the choice of the switching frequency affects the allowed input voltage range, solution size and efficiency. The maximum operation supply voltage can be found by:

$$V_{IN\_MAX} = \frac{V_{OUT}}{(f_{SW} \times T_{ON\_MIN})} \quad (5)$$

At lower supply voltage, the switching frequency will decrease once  $T_{OFF\_MIN}$  is tripped. The minimum  $V_{IN}$  without frequency foldback can be approximated by:

$$V_{IN\_MIN} = \frac{V_{OUT}}{(1 - f_{SW} \times T_{OFF\_MIN})} \quad (6)$$

Taking considerations of power losses in the system with heavy load operation,  $V_{IN\_MAX}$  is higher than the result calculated in Equation 5. With frequency foldback,  $V_{IN\_MIN}$  is lowered by decreased  $f_{SW}$ .

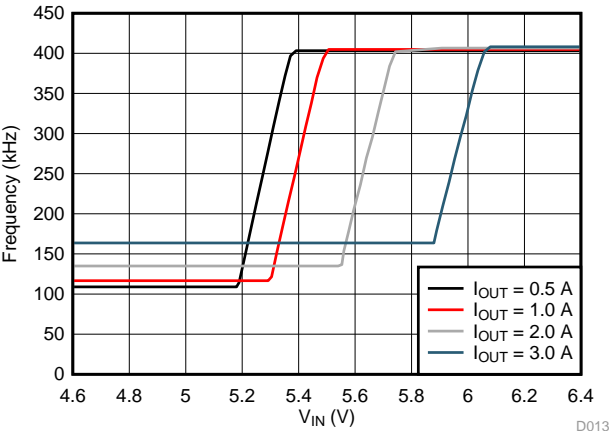

Figure 20. Frequency Foldback at Dropout ( $V_{OUT} = 5$  V,  $f_{SW} = 400$  kHz)

8.3.7 Power Good (PGOOD)

The power-good version of LMR23630-Q1 has a built-in power-good flag shown on PGOOD pin to indicate whether the output voltage is within its regulation level. The PGOOD signal can be used for start-up sequencing of multiple rails or fault protection. The PGOOD pin is an open-drain output that requires a pullup resistor to an appropriate DC voltage. Voltage detected by the PGOOD pin must never exceed 15 V, and the maximum current into this pin must be limited to 1 mA. A typical range of pullup resistor value is 10 kΩ to 100 kΩ.

When the FB voltage is within the power-good band, +6% above and -6% below the internal reference voltage  $V_{REF}$  typically, the PGOOD switch is turned off, and the PGOOD voltage is as high as the pulled-up voltage. When the FB voltage is outside of the tolerance band, +7% above or -7% below  $V_{REF}$  typically, the PGOOD switch is turned on, and the PGOOD pin voltage is pulled low to indicate power bad. A glitch filter prevents false-flag operation for short excursions in the output voltage, such as during line and load transients. The values for the various filter and delay times can be found in the *Timing Characteristics* table. Power-good operation can best be understood by reference to Figure 21.

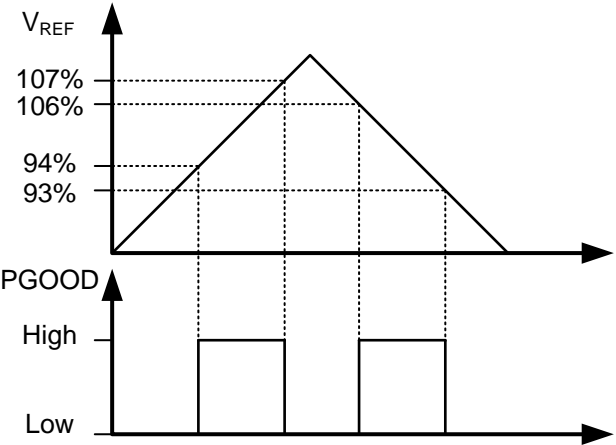
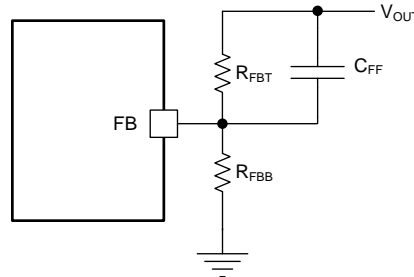

Figure 21. Power-Good Flag

### 8.3.8 Internal Compensation and $C_{FF}$

The LMR23630-Q1 is internally compensated as shown in [Functional Block Diagram](#). The internal compensation is designed such that the loop response is stable over the entire operating frequency and output voltage range. Depending on the output voltage, the compensation loop phase margin can be low with all ceramic capacitors. An external feed-forward capacitor  $C_{FF}$  is recommended to be placed in parallel with the top resistor divider  $R_{FBT}$  for optimum transient performance.



**Figure 22. Feedforward Capacitor for Loop Compensation**

The feed-forward capacitor  $C_{FF}$  in parallel with  $R_{FBT}$  places an additional zero before the cross over frequency of the control loop to boost phase margin. The zero frequency can be found by

$$f_{z\_CFF} = \frac{1}{(2\pi \times C_{FF} \times R_{FBT})} \quad (7)$$

An additional pole is also introduced with  $C_{FF}$  at the frequency of

$$f_{p\_CFF} = \frac{1}{(2\pi \times C_{FF} \times R_{FBT} // R_{FBB})} \quad (8)$$

The zero  $f_{z\_CFF}$  adds phase boost at the crossover frequency and improves transient response. The pole  $f_{p\_CFF}$  helps maintaining proper gain margin at frequency beyond the crossover. [Table 2](#) lists the combination of  $C_{OUT}$ ,  $C_{FF}$  and  $R_{FBT}$  for typical applications, designs with similar  $C_{OUT}$  but  $R_{FBT}$  other than recommended value, adjust  $C_{FF}$  such that  $(C_{FF} \times R_{FBT})$  is unchanged and adjust  $R_{FBB}$  such that  $(R_{FBT} / R_{FBB})$  is unchanged.

Designs with different combinations of output capacitors need different  $C_{FF}$ . Different types of capacitors have different equivalent series resistance (ESR). Ceramic capacitors have the smallest ESR and need the most  $C_{FF}$ . Electrolytic capacitors have much larger ESR and the ESR zero frequency would be low enough to boost the phase up around the crossover frequency. Designs using mostly electrolytic capacitors at the output may not need any  $C_{FF}$ .

$$f_{z\_ESR} = \frac{1}{(2\pi \times C_{OUT} \times ESR)} \quad (9)$$

The  $C_{FF}$  creates a time constant with  $R_{FBT}$  that couples in the attenuate output voltage ripple to the FB node. If the  $C_{FF}$  value is too large, it can couple too much ripple to the FB and affect  $V_{OUT}$  regulation. Therefore, calculate  $C_{FF}$  based on output capacitors used in the system. At cold temperatures, the value of  $C_{FF}$  might change based on the tolerance of the chosen component. This may reduce its impedance and ease noise coupling on the FB node. To avoid this, more capacitance can be added to the output or the value of  $C_{FF}$  can be reduced.

### 8.3.9 Bootstrap Voltage (BOOT)

The LMR23630-Q1 provides an integrated bootstrap voltage regulator. A small capacitor between the BOOT and SW pins provides the gate-drive voltage for the high-side MOSFET. The BOOT capacitor is refreshed when the high-side MOSFET is off and the low-side switch conducts. The recommended value of the BOOT capacitor is 0.1  $\mu$ F or higher. TI recommends ceramic capacitor with an X7R or X5R grade dielectric with a voltage rating of 16 V or higher for stable performance over temperature and voltage.

### 8.3.10 Overcurrent and Short-Circuit Protection

The LMR23630-Q1 is protected from overcurrent conditions by cycle-by-cycle current limit on both the peak and valley of the inductor current. Hiccup mode will be activated if a fault condition persists to prevent over-heating.



High-side MOSFET overcurrent protection is implemented by the nature of the peak-current-mode control. The HS switch current is sensed when the HS is turned on after a set blanking time. The HS switch current is compared to the output of the error amplifier (EA) minus slope compensation every switching cycle. See [Functional Block Diagram](#) for more details. The peak current of HS switch is limited by a clamped maximum peak current threshold  $I_{HS\_LIMIT}$  which is constant. So the peak current limit of the HS switch is not affected by the slope compensation and remains constant over the full duty-cycle range.

The current going through LS MOSFET is also sensed and monitored. When the LS switch turns on, the inductor current begins to ramp down. The LS switch is not turned OFF at the end of a switching cycle if its current is above the LS current limit  $I_{LS\_LIMIT}$ . The LS switch is kept ON so that inductor current keeps ramping down, until the inductor current ramps below the LS current limit  $I_{LS\_LIMIT}$ . The LS switch is then turned OFF, and the HS switch turned on after a dead time. This is somewhat different than the more typical peak-current limit, and results in [Equation 10](#) for the maximum load current.

$$I_{OUT\_MAX} = I_{LS\_LIMIT} + \frac{(V_{IN} - V_{OUT})}{2 \times f_{SW} \times L} \times \frac{V_{OUT}}{V_{IN}} \quad (10)$$

If the current of the LS switch is higher than the LS current limit for 64 consecutive cycles, hiccup current-protection mode is activated. In hiccup mode, the regulator is shut down and kept off for 5 ms typically before the LMR23630-Q1 tries to start again. If overcurrent or short-circuit fault condition still exist, hiccup repeats until the fault condition is removed. Hiccup mode reduces power dissipation under severe overcurrent conditions, prevents over-heating and potential damage to the device.

For FPWM option, the inductor current is allowed to go negative. If this current exceeds  $I_{L\_NEG}$ , the LS switch is turned off until the next clock cycle. This is used to protect the LS switch from excessive negative current.

### 8.3.11 Thermal Shutdown

The LMR23630-Q1 provides an internal thermal shutdown to protect the device when the junction temperature exceeds 170°C (typical). The device is turned off when thermal shutdown activates. Once the die temperature falls below 155°C (typical), the device reinitiates the power-up sequence controlled by the internal soft-start circuitry.

## 8.4 Device Functional Modes

### 8.4.1 Shutdown Mode

The EN pin provides electrical ON and OFF control for the LMR23630-Q1. When  $V_{EN}$  is below 1 V (typical), the device is in shutdown mode. The LMR23630-Q1 also employs  $V_{IN}$  and  $V_{CC}$  UVLO protection. If  $V_{IN}$  or  $V_{CC}$  voltage is below their respective UVLO level, the regulator is turned off.

### 8.4.2 Active Mode

The LMR23630-Q1 is in active mode when  $V_{EN}$  is above the precision enable threshold,  $V_{IN}$  and  $V_{CC}$  are above their respective UVLO level. The simplest way to enable the LMR23630-Q1 is to connect the EN pin to  $V_{IN}$  pin. This allows self startup when the input voltage is in the operating range: 4 V to 36 V. See [VCC](#), [UVLO](#) and [Enable/Synchronization](#) for details on setting these operating levels.

In active mode, depending on the load current, the LMR23630-Q1 is in one of four modes:

1. Continuous conduction mode (CCM) with fixed switching frequency when load current is above half of the peak-to-peak inductor current ripple (for both PFM and FPWM options).
2. Discontinuous conduction mode (DCM) with fixed switching frequency when load current is lower than half of the peak-to-peak inductor current ripple in CCM operation (only for PFM option).
3. Pulse frequency modulation mode (PFM) when switching frequency is decreased at very light load (only for PFM option).
4. Forced pulse width modulation mode (FPWM) with fixed switching frequency even at light load (only for FPWM option).

### 8.4.3 CCM Mode

CCM operation is employed in the LMR23630-Q1 when the load current is higher than half of the peak-to-peak inductor current. In CCM operation, the frequency of operation is fixed, output voltage ripple will be at a minimum in this mode and the maximum output current of 3 A can be supplied by the LMR23630-Q1.

### 8.4.4 Light Load Operation (PFM Option)

For PFM option, when the load current is lower than half of the peak-to-peak inductor current in CCM, the LMR23630-Q1 operates in DCM, also known as Diode Emulation Mode (DEM). In DCM, the LS switch is turned off when the inductor current drops to  $I_{L\_ZC}$  (–40 mA typical). Both switching losses and conduction losses are reduced in DCM, compared to forced PWM operation at light load.

At even lighter current loads, PFM is activated to maintain high efficiency operation. When either the minimum HS switch ON-time ( $t_{ON\_MIN}$ ) or the minimum peak inductor current  $I_{PEAK\_MIN}$  (300 mA typical) is reached, the switching frequency decreases to maintain regulation. In PFM, switching frequency is decreased by the control loop when load current reduces to maintain output voltage regulation. Switching loss is further reduced in PFM operation due to less frequent switching actions. The external clock synchronizing is not be valid when LMR23630-Q1 enters into PFM mode.

### 8.4.5 Light Load Operation (FPWM Option)

For FPWM option, LMR23630-Q1 is locked in PWM mode at full load range. This operation is maintained, even at no-load, by allowing the inductor current to reverse its normal direction. This mode trades off reduced light load efficiency for low output voltage ripple, tight output voltage regulation, and constant switching frequency. In this mode, a negative current limit of  $I_{L\_NEG}$  is imposed to prevent damage to the regulators LS FET. When in FPWM mode the converter synchronizes to any valid clock signal on the EN/SYNC input.

## 9 Application and Implementation

### NOTE

Information in the following applications sections is not part of the TI component specification, and TI does not warrant its accuracy or completeness. TI's customers are responsible for determining suitability of components for their purposes. Customers should validate and test their design implementation to confirm system functionality.

### 9.1 Application Information

The LMR23630-Q1 is a step-down DC-to-DC regulator. It is typically used to convert a higher DC voltage to a lower DC voltage with a maximum output current of 3 A. The following design procedure can be used to select components for the LMR23630-Q1. Alternately, the WEBENCH software may be used to generate complete designs. When generating a design, the WEBENCH software utilizes iterative design procedure and accesses comprehensive databases of components. See [Custom Design With WEBENCH® Tools](#) and ti.com for more details.

### 9.2 Typical Applications

The LMR23630-Q1 only requires a few external components to convert from a wide voltage range supply to a fixed output voltage. [Figure 23](#) shows a basic schematic.

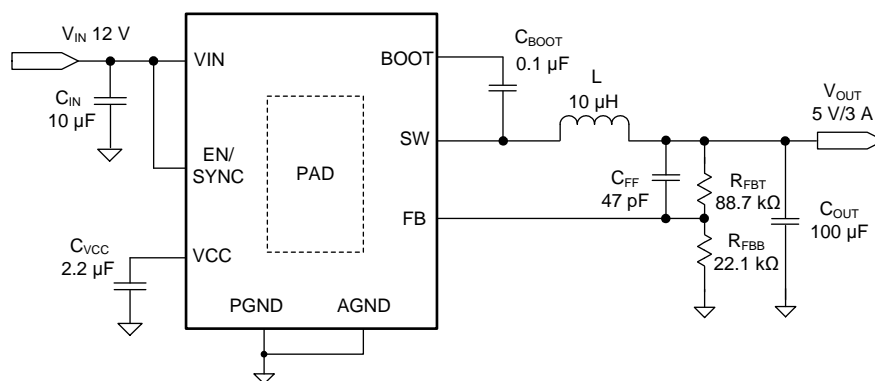

Copyright © 2016, Texas Instruments Incorporated

**Figure 23. Application Circuit**

The external components have to fulfill the needs of the application, but also the stability criteria of the device control loop. [Table 2](#) can be used to simplify the output filter component selection.

**Table 2. L, C<sub>OUT</sub> and C<sub>FF</sub> Typical Values**

f <sub>sw</sub> (kHz)	V <sub>OUT</sub> (V)	L (µH) <sup>(1)</sup>	C <sub>OUT</sub> (µF) <sup>(2)</sup>	C <sub>FF</sub> (pF)	R <sub>FBT</sub> (kΩ) <sup>(3)</sup>
400	3.3	6.8	150	75	51
400	5	10	100	47	88.7
400	12	15	68	See note <sup>(4)</sup>	243
400	24	15	47	See note <sup>(4)</sup>	510

- (1) Inductance value is calculated based on V<sub>IN</sub> = 36 V.
- (2) All the C<sub>OUT</sub> values are after derating. Add more when using ceramic capacitors.
- (3) R<sub>FBT</sub> = 0 Ω for V<sub>OUT</sub> = 1 V. R<sub>FBB</sub> = 22.1 kΩ for all other V<sub>OUT</sub> setting.
- (4) High ESR C<sub>OUT</sub> gives enough phase boost, and C<sub>FF</sub> not needed.

## 9.2.1 Design Requirements

Detailed design procedure is described based on a design example. For this design example, use the parameters listed in [Table 3](#) as the input parameters.

**Table 3. Design Example Parameters**

DESIGN PARAMETER	EXAMPLE VALUE
Input voltage, $V_{IN}$	12 V typical, range from 8 V to 28 V
Output voltage, $V_{OUT}$	5 V
Maximum output current $I_{O\_MAX}$	3 A
Transient Response 0.3 A to 3 A	5%
Output voltage ripple	50 mV
Input voltage ripple	400 mV
Switching frequency $f_{SW}$	400 kHz

## 9.2.2 Detailed Design Procedure

### 9.2.2.1 Custom Design With WEBENCH® Tools

[Click here](#) to create a custom design using the LMR23630-Q1 device with the WEBENCH® Power Designer.

1. Start by entering the input voltage ( $V_{IN}$ ), output voltage ( $V_{OUT}$ ), and output current ( $I_{OUT}$ ) requirements.
2. Optimize the design for key parameters such as efficiency, footprint, and cost using the optimizer dial.
3. Compare the generated design with other possible solutions from Texas Instruments.

The WEBENCH Power Designer provides a customized schematic along with a list of materials with real-time pricing and component availability.

In most cases, these actions are available:

- Run electrical simulations to see important waveforms and circuit performance
- Run thermal simulations to understand board thermal performance
- Export customized schematic and layout into popular CAD formats
- Print PDF reports for the design, and share the design with colleagues

Get more information about WEBENCH tools at [www.ti.com/WEBENCH](http://www.ti.com/WEBENCH).

### 9.2.2.2 Output Voltage Setpoint

The output voltage of LMR23630-Q1 is externally adjustable using a resistor divider network. The divider network is comprised of top feedback resistor  $R_{FBT}$  and bottom feedback resistor  $R_{FBB}$ . [Equation 11](#) is used to determine the output voltage:

$$R_{FBT} = \frac{V_{OUT} - V_{REF}}{V_{REF}} \times R_{FBB} \quad (11)$$

Choose the value of  $R_{FBB}$  to be 22.1 k $\Omega$ . With the desired output voltage set to 5 V and the  $V_{REF} = 1$  V, the  $R_{FBB}$  value can then be calculated using [Equation 11](#). The formula yields to a value 88.7 k $\Omega$ .

### 9.2.2.3 Switching Frequency

The default switching frequency of the LMR23630-Q1 is 400 kHz. For other required switching frequency, adjust  $R_T$  value or synchronize the device to an external clock to get the target frequency, refer to [Adjustable Frequency](#) and [Enable/Synchronization](#) for more details.

### 9.2.2.4 Inductor Selection

The most critical parameters for the inductor are the inductance, saturation current, and the rated current. The inductance is based on the desired peak-to-peak ripple current  $\Delta i_L$ . Since the ripple current increases with the input voltage, the maximum input voltage is always used to calculate the minimum inductance  $L_{MIN}$ . Use [Equation 13](#) to calculate the minimum value of the output inductor.  $K_{IND}$  is a coefficient that represents the amount of inductor ripple current relative to the maximum output current of the device. A reasonable value of  $K_{IND}$  should be 20% to 40%. During an instantaneous short or over current operation event, the RMS and peak inductor current can be high. The inductor current rating should be higher than the current limit of the device.

$$\Delta i_L = \frac{V_{OUT} \times (V_{IN\_MAX} - V_{OUT})}{V_{IN\_MAX} \times L \times f_{SW}} \quad (12)$$

$$L_{MIN} = \frac{V_{IN\_MAX} - V_{OUT}}{I_{OUT} \times K_{IND}} \times \frac{V_{OUT}}{V_{IN\_MAX} \times f_{SW}} \quad (13)$$

In general, it is preferable to choose lower inductance in switching power supplies, because it usually corresponds to faster transient response, smaller DCR, and reduced size for more compact designs. But too low of an inductance can generate too large of an inductor current ripple such that over current protection at the full load could be falsely triggered. It also generates more conduction loss and inductor core loss. Larger inductor current ripple also implies larger output voltage ripple with same output capacitors. With peak-current-mode control, TI recommends not to have an inductor current ripple that is too small. A larger peak current ripple improves the comparator signal-to-noise ratio.

For this design example, choose  $K_{IND} = 0.4$ , the minimum inductor value is calculated to be 8.56  $\mu\text{H}$ . Choose the nearest standard 8.2- $\mu\text{H}$  ferrite inductor with a capability of 4-A RMS current and 6-A saturation current.

### 9.2.2.5 Output Capacitor Selection

Choose the output capacitor(s),  $C_{OUT}$ , with care since it directly affects the steady state output voltage ripple, loop stability, and the voltage over/undershoot during load current transients.

The output ripple is essentially composed of two parts. One is caused by the inductor current ripple going through the ESR of the output capacitors:

$$\Delta V_{OUT\_ESR} = \Delta i_L \times ESR = K_{IND} \times I_{OUT} \times ESR \quad (14)$$

The other is caused by the inductor current ripple charging and discharging the output capacitors:

$$\Delta V_{OUT\_C} = \frac{\Delta i_L}{(8 \times f_{SW} \times C_{OUT})} = \frac{K_{IND} \times I_{OUT}}{(8 \times f_{SW} \times C_{OUT})} \quad (15)$$

The two components in the voltage ripple are not in phase, so the actual peak-to-peak ripple is smaller than the sum of two peaks.

Output capacitance is usually limited by transient performance specifications if the system requires tight voltage regulation with presence of large current steps and fast slew rate. When a fast large load increase happens, output capacitors provide the required charge before the inductor current can slew up to the appropriate level. The regulator's control loop usually needs four or more clock cycles to respond to the output voltage droop. The output capacitance must be large enough to supply the current difference for four clock cycles to maintain the output voltage within the specified range. [Equation 16](#) shows the minimum output capacitance needed for specified output undershoot. When a sudden large load decrease happens, the output capacitors absorb energy stored in the inductor, which results in an output voltage overshoot. [Equation 17](#) calculates the minimum capacitance required to keep the voltage overshoot within a specified range.

$$C_{OUT} > \frac{4 \times (I_{OH} - I_{OL})}{f_{SW} \times V_{US}} \quad (16)$$

$$C_{OUT} > \frac{I_{OH}^2 - I_{OL}^2}{(V_{OUT} + V_{OS})^2 - V_{OUT}^2}$$

where

- $K_{IND}$  = Ripple ratio of the inductor ripple current ( $\Delta i_L / I_{OUT}$ )
  - $I_{OL}$  = Low level output current during load transient
  - $I_{OH}$  = High level output current during load transient
  - $V_{US}$  = Target output voltage undershoot
  - $V_{OS}$  = Target output voltage overshoot
- (17)

For this design example, the target output ripple is 50 mV. Presuppose  $\Delta V_{OUT\_ESR} = \Delta V_{OUT\_C} = 50$  mV, and chose  $K_{IND} = 0.4$ . Equation 14 yields ESR no larger than 41.7 mΩ and Equation 15 yields  $C_{OUT}$  no smaller than 7.5 μF. For the target over/undershoot range of this design,  $V_{US} = V_{OS} = 5\% \times V_{OUT} = 250$  mV. The  $C_{OUT}$  can be calculated to be no smaller than 108 μF and 28.5 μF by Equation 16 and Equation 17 respectively. Consider of derating, one 47-μF, 16-V and one 100-μF, 10-V ceramic capacitor with 5-mΩ ESR are used in parallel.

### 9.2.2.6 Feed-Forward Capacitor

The LMR23630-Q1 is internally compensated. Depending on the  $V_{OUT}$  and frequency  $f_{SW}$ , if the output capacitor  $C_{OUT}$  is dominated by low ESR (ceramic types) capacitors, it could result in low phase margin. To improve the phase boost an external feed-forward capacitor  $C_{FF}$  can be added in parallel with  $R_{FBT}$ .  $C_{FF}$  is chosen such that phase margin is boosted at the crossover frequency without  $C_{FF}$ . A simple estimation for the crossover frequency ( $f_X$ ) without  $C_{FF}$  is shown in Equation 18, assuming  $C_{OUT}$  has very small ESR, and  $C_{OUT}$  value is after derating.

$$f_X = \frac{8.32}{V_{OUT} \times C_{OUT}} \quad (18)$$

Equation 19 for  $C_{FF}$  was tested:

$$C_{FF} = \frac{1}{4\pi \times f_X \times R_{FBT}} \quad (19)$$

For designs with higher ESR,  $C_{FF}$  is not needed when  $C_{OUT}$  has very high ESR and  $C_{FF}$  calculated from Equation 19 should be reduced with medium ESR. Table 2 can be used as a quick starting point.

For the application in this design example, a 47-pF, 50-V, COG capacitor is selected.

### 9.2.2.7 Input Capacitor Selection

The LMR23630-Q1 device requires high-frequency input decoupling capacitor(s) and a bulk input capacitor, depending on the application. The typical recommended value for the high-frequency decoupling capacitor is 4.7 μF to 10 μF. TI recommends a high-quality ceramic capacitor type X5R or X7R with sufficiency voltage rating. To compensate the derating of ceramic capacitors, a voltage rating of twice the maximum input voltage is recommended. Additionally, some bulk capacitance can be required, especially if the LMR23630-Q1 circuit is not located within approximately 5 cm from the input voltage source. This capacitor is used to provide damping to the voltage spike due to the lead inductance of the cable or the trace. For this design, two 4.7-μF, 50-V, X7R ceramic capacitors are used. Use 0.1-μF for high-frequency filtering and place it as close as possible to the device pins.

### 9.2.2.8 Bootstrap Capacitor Selection

Every LMR23630-Q1 design requires a bootstrap capacitor ( $C_{BOOT}$ ). The recommended capacitor is 0.1 μF and rated 16 V or higher. The bootstrap capacitor is located between the SW pin and the BOOT pin. The bootstrap capacitor must be a high-quality ceramic type with an X7R or X5R grade dielectric for temperature stability.

### 9.2.2.9 VCC Capacitor Selection

The VCC pin is the output of an internal LDO for LMR23630-Q1. To insure stability of the device, place a minimum of 2.2- $\mu$ F, 16-V, X7R capacitor from this pin to ground.

### 9.2.2.10 UVLO Setpoint

The system UVLO is adjusted using the external voltage divider network of  $R_{ENT}$  and  $R_{ENB}$ . The UVLO has two thresholds, one for power up when the input voltage is rising and one for power down or brownouts when the input voltage is falling. Use [Equation 20](#) to determine the  $V_{IN}$  UVLO level.

$$V_{IN\_RISING} = V_{ENH} \times \frac{R_{ENT} + R_{ENB}}{R_{ENB}} \quad (20)$$

The EN rising threshold ( $V_{ENH}$ ) for LMR23630-Q1 is set to be 1.55 V (typical). Choose the value of  $R_{ENB}$  to be 287 k $\Omega$  to minimize input current from the supply. If the desired  $V_{IN}$  UVLO level is at 6 V, then the value of  $R_{ENT}$  can be calculated using [Equation 21](#):

$$R_{ENT} = \left( \frac{V_{IN\_RISING}}{V_{ENH}} - 1 \right) \times R_{ENB} \quad (21)$$

[Equation 21](#) yields a value of 820 k $\Omega$ . The resulting falling UVLO threshold, equals 4.4 V, can be calculated by [Equation 22](#), where EN hysteresis ( $V_{EN\_HYS}$ ) is 0.4 V (typical).

$$V_{IN\_FALLING} = (V_{ENH} - V_{EN\_HYS}) \times \frac{R_{ENT} + R_{ENB}}{R_{ENB}} \quad (22)$$

### 9.2.3 Application Curves

Unless otherwise specified the following conditions apply:  $V_{IN} = 12\text{ V}$ ,  $f_{SW} = 400\text{ kHz}$ ,  $L = 8.2\text{ }\mu\text{H}$ ,  $C_{OUT} = 150\text{ }\mu\text{F}$ ,  $T_A = 25\text{ }^\circ\text{C}$ .

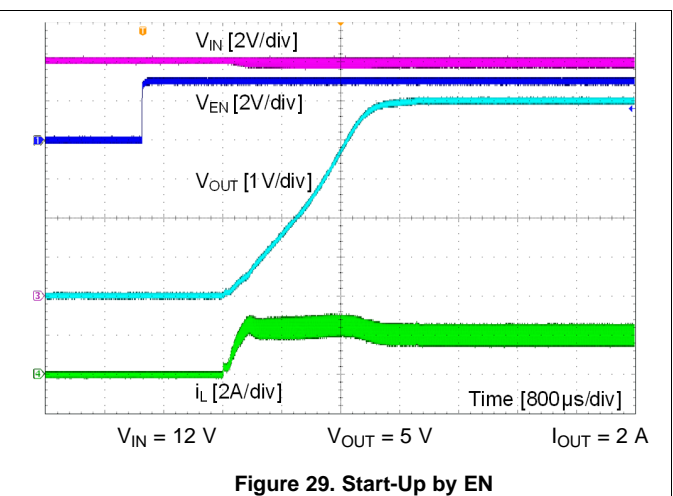
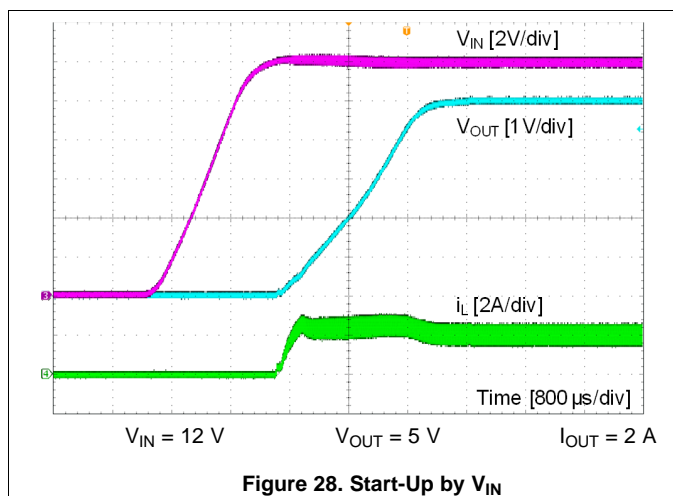
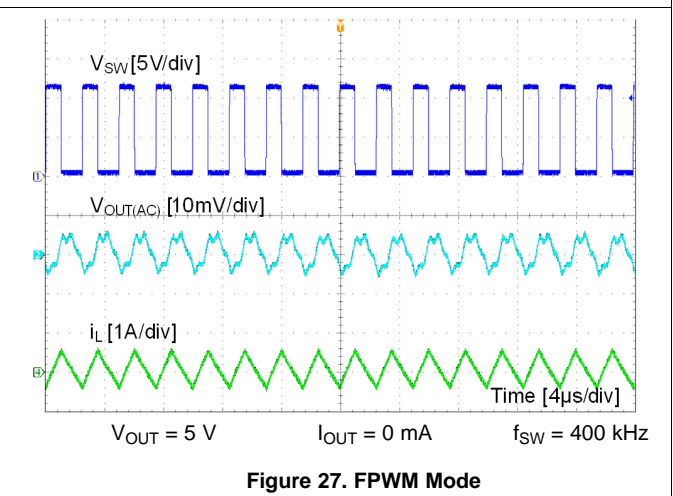
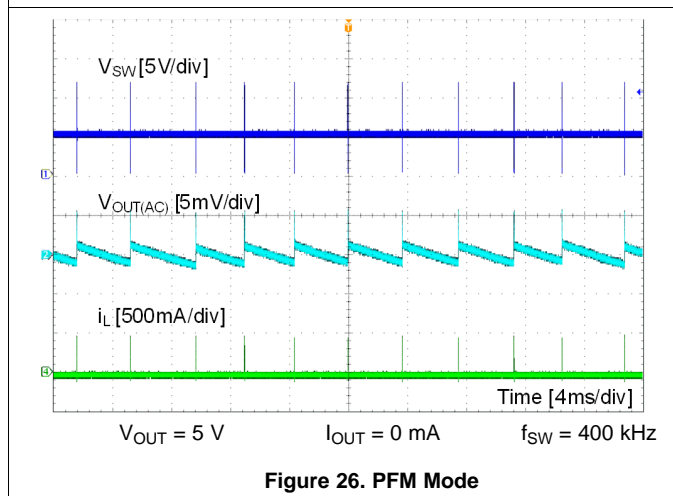
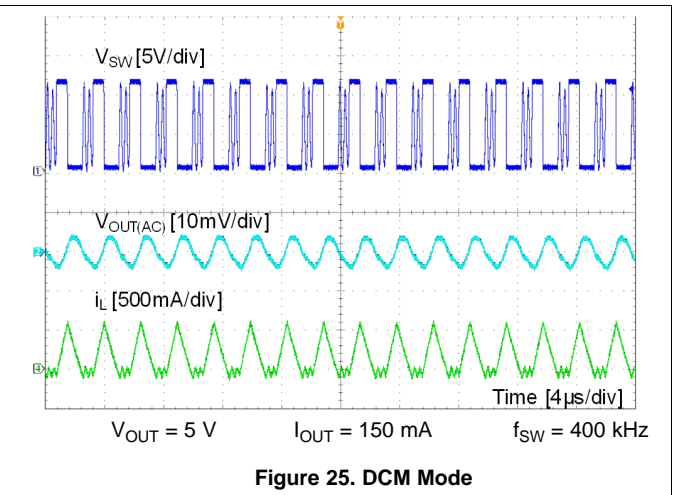
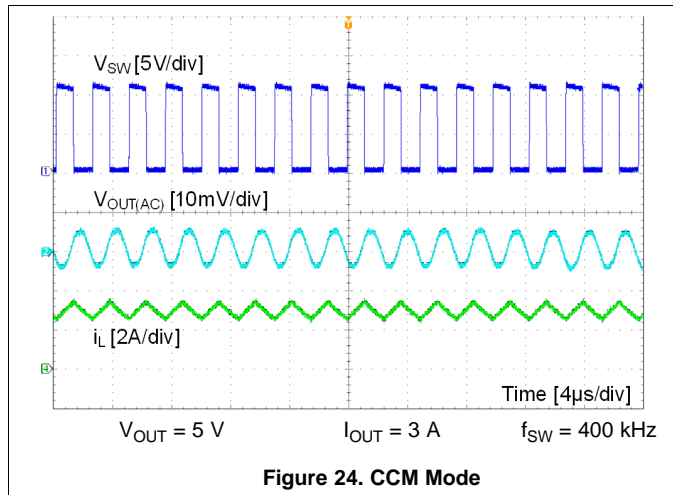



Unless otherwise specified the following conditions apply:  $V_{IN} = 12\text{ V}$ ,  $f_{SW} = 400\text{ kHz}$ ,  $L = 8.2\text{ }\mu\text{H}$ ,  $C_{OUT} = 150\text{ }\mu\text{F}$ ,  $T_A = 25\text{ }^\circ\text{C}$ .

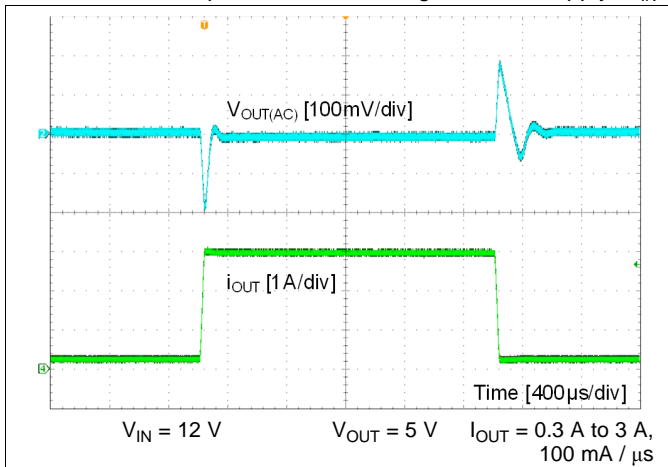

Figure 30. Load Transient

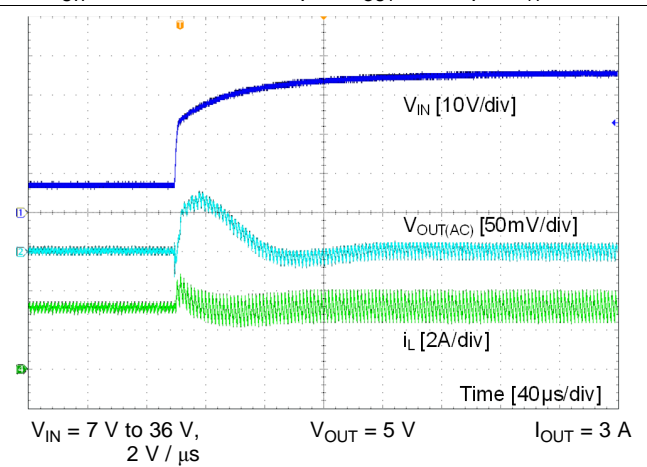

Figure 31. Line Transient

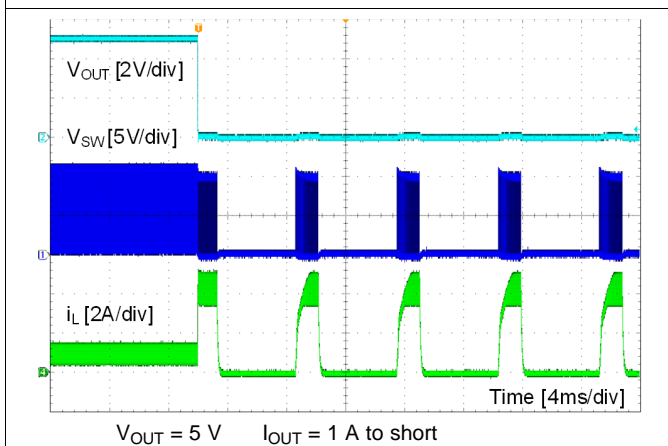

Figure 32. Short Protection

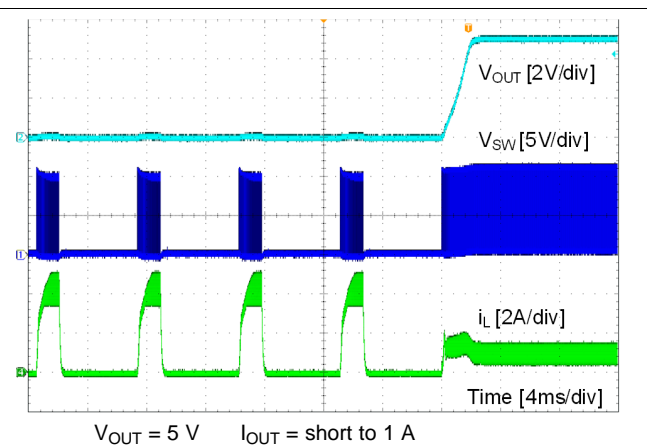

Figure 33. Short Recovery

## 10 Power Supply Recommendations

The LMR23630-Q1 is designed to operate from an input voltage supply range between 4 V and 36 V. This input supply must be able to withstand the maximum input current and maintain a stable voltage. The resistance of the input supply rail must be low enough that an input current transient does not cause a high enough drop at the LMR23630-Q1 supply voltage that can cause a false UVLO fault triggering and system reset. If the input supply is located more than a few inches from the LMR23630-Q1, additional bulk capacitance may be required in addition to the ceramic input capacitors. The amount of bulk capacitance is not critical, but a 47- $\mu$ F or 100- $\mu$ F electrolytic capacitor is a typical choice.

## 11 Layout

### 11.1 Layout Guidelines

Layout is a critical portion of good power supply design. The following guidelines will help users design a PCB with the best power conversion performance, thermal performance, and minimized generation of unwanted EMI.

1. The input bypass capacitor  $C_{IN}$  must be placed as close as possible to the VIN and PGND pins. Grounding for both the input and output capacitors must consist of localized top side planes that connect to the PGND pin and PAD.
2. Place bypass capacitors for  $V_{CC}$  close to the VCC pin and ground the bypass capacitor to device ground.
3. Minimize trace length to the FB pin net. Locate both feedback resistors,  $R_{FBT}$  and  $R_{FBB}$  close to the FB pin. Place  $C_{FF}$  directly in parallel with  $R_{FBT}$ . If  $V_{OUT}$  accuracy at the load is important, make sure  $V_{OUT}$  sense is made at the load. Route  $V_{OUT}$  sense path away from noisy nodes and preferably through a layer on the other side of a shielded layer.
4. Use ground plane in one of the middle layers as noise shielding and heat-dissipation path.
5. Have a single point ground connection to the plane. Route the ground connections for the feedback and enable components to the ground plane. This prevents any switched or load currents from flowing in the analog ground traces. If not properly handled, poor grounding can result in degraded load regulation or erratic output voltage ripple behavior.
6. Make  $V_{IN}$ ,  $V_{OUT}$  and ground bus connections as wide as possible. This reduces any voltage drops on the input or output paths of the converter and maximizes efficiency.
7. Provide adequate device heat-sinking. Use an array of heat-sinking vias to connect the exposed pad to the ground plane on the bottom PCB layer. If the PCB has multiple copper layers, these thermal vias can also be connected to inner layer heat-spreading ground planes. Ensure enough copper area is used for heat sinking to keep the junction temperature below 125°C.

#### 11.1.1 Compact Layout for EMI Reduction

Radiated EMI is generated by the high di/dt components in pulsing currents in switching converters. The larger area covered by the path of a pulsing current, the more EMI is generated. High frequency ceramic bypass capacitors at the input side provide primary path for the high di/dt components of the pulsing current. Placing ceramic bypass capacitor(s) as close as possible to the VIN and PGND pins is the key to EMI reduction.

The SW pin connecting to the inductor must be as short as possible, and just wide enough to carry the load current without excessive heating. Use short, thick traces or copper pours (shapes) for high current conduction path to minimize parasitic resistance. The output capacitors must be placed close to the  $V_{OUT}$  end of the inductor and closely grounded to PGND pin and exposed PAD.

Place the bypass capacitors on VCC as close as possible to the pin and closely grounded to PGND and the exposed PAD.

## Layout Guidelines (continued)

### 11.1.2 Ground Plane and Thermal Considerations

It is recommended to use one of the middle layers as a solid ground plane. Ground plane provides shielding for sensitive circuits and traces. It also provides a quiet reference potential for the control circuitry. Connect the AGND and PGND pins to the ground plane using vias right next to the bypass capacitors. PGND pin is connected to the source of the internal LS switch. They must be connected directly to the grounds of the input and output capacitors. The PGND net contains noise at switching frequency and may bounce due to load variations. PGND trace, as well as VIN and SW traces, must be constrained to one side of the ground plane. The other side of the ground plane contains much less noise and should be used for sensitive routes.

It is recommended to provide adequate device heat sinking by utilizing the PAD of the IC as the primary thermal path. Use a minimum 4 by 2 array of 12 mil thermal vias to connect the PAD to the system ground plane heat sink. The vias must be evenly distributed under the PAD. Use as much copper as possible, for system ground plane, on the top and bottom layers for the best heat dissipation. Use a four-layer board with the copper thickness for the four layers, starting from the top of, 2 oz / 1 oz / 1 oz / 2 oz. Four layer boards with enough copper thickness provides low current conduction impedance, proper shielding and lower thermal resistance.

The thermal characteristics of the LMR23630-Q1 are specified using the parameter  $R_{\theta JA}$ , which characterize the junction temperature of silicon to the ambient temperature in a specific system. Although the value of  $R_{\theta JA}$  is dependent on many variables, it still can be used to approximate the operating junction temperature of the device. To obtain an estimate of the device junction temperature, one may use [Equation 23](#):

$$T_J = P_D \times R_{\theta JA} + T_A$$

where

- $T_J$  = Junction temperature in °C
- $P_D = V_{IN} \times I_{IN} \times (1 - \text{Efficiency}) - 1.1 \times I_{OUT}^2 \times \text{DCR}$  in Watt
- DCR = Inductor DC parasitic resistance in  $\Omega$
- $R_{\theta JA}$  = Junction to ambient thermal resistance of the device in °C/W
- $T_A$  = Ambient temperature in °C

(23)

The maximum operating junction temperature of the LMR23630-Q1 is 125°C.  $R_{\theta JA}$  is highly related to PCB size and layout, as well as environmental factors such as heat sinking and air flow.

### 11.1.3 Feedback Resistors

To reduce noise sensitivity of the output voltage feedback path, it is important to place the resistor divider and  $C_{FF}$  close to the FB pin, rather than close to the load. The FB pin is the input to the error amplifier, so it is a high impedance node and very sensitive to noise. Placing the resistor divider and  $C_{FF}$  closer to the FB pin reduces the trace length of FB signal and reduces noise coupling. The output node is a low impedance node, so the trace from  $V_{OUT}$  to the resistor divider can be long if short path is not available.

If voltage accuracy at the load is important, make sure voltage sense is made at the load. Doing so corrects for voltage drops along the traces and provide the best output accuracy. Route the voltage sense trace from the load to the feedback resistor divider away from the SW node path and the inductor to avoid contaminating the feedback signal with switch noise, while also minimizing the trace length. This is most important when high value resistors are used to set the output voltage. TI recommends routing the voltage sense trace and place the resistor divider on a different layer than the inductor and SW node path, such that there is a ground plane in between the feedback trace and inductor/SW node polygon. This provides further shielding for the voltage feedback path from EMI noises.

## 11.2 Layout Examples

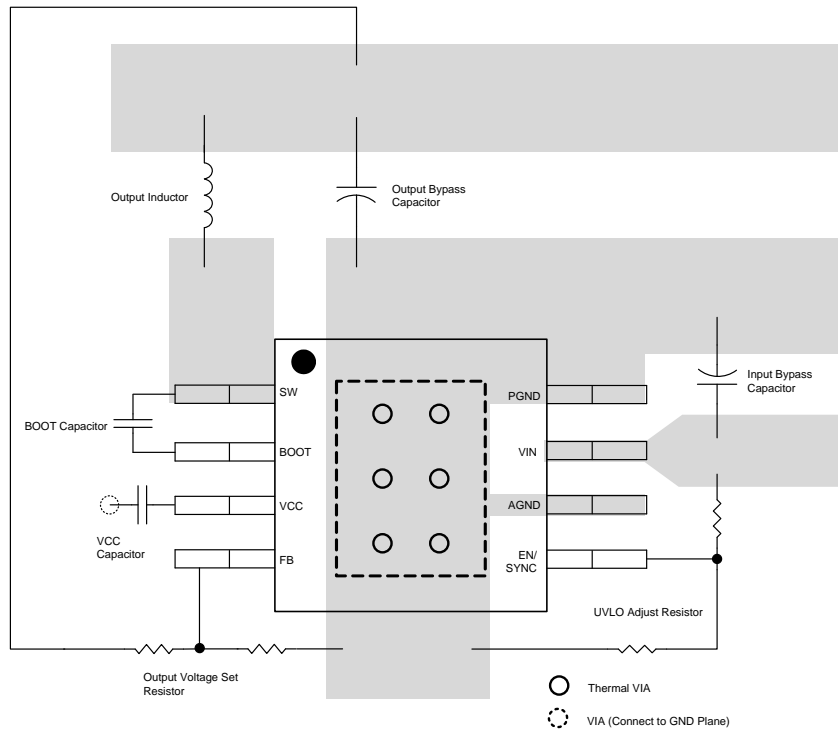

Figure 34. SOIC Layout

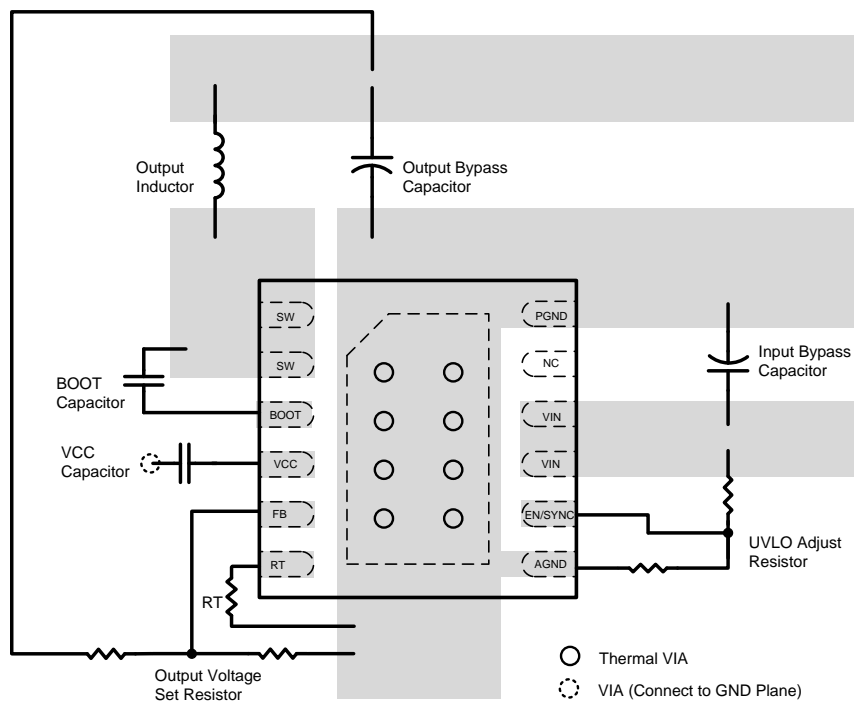

Figure 35. WSON Layout

## 12 器件和文档支持

### 12.1 使用 WEBENCH® 工具创建定制设计

请[单击此处](#)，结合 LMR23630-Q1 器件和 WEBENCH® 电源设计器创建定制设计。

1. 首先键入输入电压 ( $V_{IN}$ )、输出电压 ( $V_{OUT}$ ) 和输出电流 ( $I_{OUT}$ ) 要求。
2. 使用优化器拨盘优化关键参数设计，如效率、封装和成本。
3. 将生成的设计与德州仪器 (TI) 的其他解决方案进行比较。

WEBENCH 电源设计器可提供定制原理图以及罗列实时价格和组件供货情况的物料清单。

在多数情况下，可执行以下操作：

- 运行电气仿真，观察重要波形以及电路性能
- 运行热性能仿真，了解电路板热性能
- 将定制原理图和布局方案导出至常用 CAD 格式
- 打印设计方案的 PDF 报告并与同事共享

有关 WEBENCH 工具的详细信息，请访问 [www.ti.com/WEBENCH](http://www.ti.com/WEBENCH)。

### 12.2 接收文档更新通知

要接收文档更新通知，请导航至 [TI.com.cn](http://TI.com.cn) 上的器件产品文件夹。请单击右上角的提醒我 进行注册，即可每周接收产品信息更改摘要。有关更改的详细信息，请查看任何已修订文档中包含的修订历史记录。

### 12.3 社区资源

下列链接提供到 TI 社区资源的连接。链接的内容由各个分销商“按照原样”提供。这些内容并不构成 TI 技术规范，并且不一定反映 TI 的观点；请参阅 TI 的《使用条款》。

**TI E2E™ 在线社区** *TI 的工程师对工程师 (E2E) 社区*。此社区的创建目的在于促进工程师之间的协作。在 [e2e.ti.com](http://e2e.ti.com) 中，您可以咨询问题、分享知识、拓展思路并与同行工程师一道帮助解决问题。

**设计支持** *TI 参考设计支持* 可帮助您快速查找有帮助的 E2E 论坛、设计支持工具以及技术支持的联系信息。

### 12.4 商标

PowerPAD, E2E are trademarks of Texas Instruments.

WEBENCH, SIMPLE SWITCHER are registered trademarks of Texas Instruments.

All other trademarks are the property of their respective owners.

### 12.5 静电放电警告



这些装置包含有限的内置 ESD 保护。存储或装卸时，应将导线一起截短或将装置放置于导电泡棉中，以防止 MOS 门极遭受静电损伤。

### 12.6 Glossary

[SLYZ022](#) — *TI Glossary*.

This glossary lists and explains terms, acronyms, and definitions.

## 13 机械、封装和可订购信息

以下页面包含机械、封装和可订购信息。这些信息是指定器件的最新可用数据。数据如有变更，恕不另行通知，且不会对此文档进行修订。如需获取此数据表的浏览器版本，请查阅左侧的导航栏。

**PACKAGING INFORMATION**

Orderable Device	Status (1)	Package Type	Package Drawing	Pins	Package Qty	Eco Plan (2)	Lead finish/ Ball material (6)	MSL Peak Temp (3)	Op Temp (°C)	Device Marking (4/5)	Samples
LMR23630AFQDDAQ1	ACTIVE	SO PowerPAD	DDA	8	75	RoHS & Green	NIPDAUAG	Level-2-260C-1 YEAR	-40 to 125	F30AFQ	<a href="#">Samples</a>
LMR23630AFQDDARQ1	ACTIVE	SO PowerPAD	DDA	8	2500	RoHS & Green	NIPDAUAG	Level-2-260C-1 YEAR	-40 to 125	F30AFQ	<a href="#">Samples</a>
LMR23630APQDRRRQ1	ACTIVE	WSON	DRR	12	3000	RoHS & Green	SN	Level-2-260C-1 YEAR	-40 to 125	363PQ	<a href="#">Samples</a>
LMR23630APQDRRTQ1	ACTIVE	WSON	DRR	12	250	RoHS & Green	SN	Level-2-260C-1 YEAR	-40 to 125	363PQ	<a href="#">Samples</a>
LMR23630AQDDAQ1	ACTIVE	SO PowerPAD	DDA	8	75	RoHS & Green	NIPDAUAG	Level-2-260C-1 YEAR	-40 to 125	F30AQ	<a href="#">Samples</a>
LMR23630AQDDARQ1	ACTIVE	SO PowerPAD	DDA	8	2500	RoHS & Green	NIPDAUAG	Level-2-260C-1 YEAR	-40 to 125	F30AQ	<a href="#">Samples</a>
LMR23630FQDRRRQ1	ACTIVE	WSON	DRR	12	3000	RoHS & Green	SN	Level-2-260C-1 YEAR	-40 to 125	363FQ	<a href="#">Samples</a>
LMR23630FQDRRTQ1	ACTIVE	WSON	DRR	12	250	RoHS & Green	SN	Level-2-260C-1 YEAR	-40 to 125	363FQ	<a href="#">Samples</a>
LMR23630QDRRRQ1	ACTIVE	WSON	DRR	12	3000	RoHS & Green	SN	Level-2-260C-1 YEAR	-40 to 125	3630Q	<a href="#">Samples</a>
LMR23630QDRRTQ1	ACTIVE	WSON	DRR	12	250	RoHS & Green	SN	Level-2-260C-1 YEAR	-40 to 125	3630Q	<a href="#">Samples</a>

(1) The marketing status values are defined as follows:

**ACTIVE:** Product device recommended for new designs.

**LIFEBUY:** TI has announced that the device will be discontinued, and a lifetime-buy period is in effect.

**NRND:** Not recommended for new designs. Device is in production to support existing customers, but TI does not recommend using this part in a new design.

**PREVIEW:** Device has been announced but is not in production. Samples may or may not be available.

**OBSOLETE:** TI has discontinued the production of the device.

(2) **RoHS:** TI defines "RoHS" to mean semiconductor products that are compliant with the current EU RoHS requirements for all 10 RoHS substances, including the requirement that RoHS substance do not exceed 0.1% by weight in homogeneous materials. Where designed to be soldered at high temperatures, "RoHS" products are suitable for use in specified lead-free processes. TI may reference these types of products as "Pb-Free".

**RoHS Exempt:** TI defines "RoHS Exempt" to mean products that contain lead but are compliant with EU RoHS pursuant to a specific EU RoHS exemption.

**Green:** TI defines "Green" to mean the content of Chlorine (Cl) and Bromine (Br) based flame retardants meet JS709B low halogen requirements of <=1000ppm threshold. Antimony trioxide based flame retardants must also meet the <=1000ppm threshold requirement.

(3) MSL, Peak Temp. - The Moisture Sensitivity Level rating according to the JEDEC industry standard classifications, and peak solder temperature.

(4) There may be additional marking, which relates to the logo, the lot trace code information, or the environmental category on the device.

<sup>(5)</sup> Multiple Device Markings will be inside parentheses. Only one Device Marking contained in parentheses and separated by a "~" will appear on a device. If a line is indented then it is a continuation of the previous line and the two combined represent the entire Device Marking for that device.

<sup>(6)</sup> Lead finish/Ball material - Orderable Devices may have multiple material finish options. Finish options are separated by a vertical ruled line. Lead finish/Ball material values may wrap to two lines if the finish value exceeds the maximum column width.

**Important Information and Disclaimer:**The information provided on this page represents TI's knowledge and belief as of the date that it is provided. TI bases its knowledge and belief on information provided by third parties, and makes no representation or warranty as to the accuracy of such information. Efforts are underway to better integrate information from third parties. TI has taken and continues to take reasonable steps to provide representative and accurate information but may not have conducted destructive testing or chemical analysis on incoming materials and chemicals. TI and TI suppliers consider certain information to be proprietary, and thus CAS numbers and other limited information may not be available for release.

In no event shall TI's liability arising out of such information exceed the total purchase price of the TI part(s) at issue in this document sold by TI to Customer on an annual basis.

## TAPE AND REEL INFORMATION



### QUADRANT ASSIGNMENTS FOR PIN 1 ORIENTATION IN TAPE



\*All dimensions are nominal

Device	Package Type	Package Drawing	Pins	SPQ	Reel Diameter (mm)	Reel Width W1 (mm)	A0 (mm)	B0 (mm)	K0 (mm)	P1 (mm)	W (mm)	Pin1 Quadrant
LMR23630AFQDDARQ1	SO Power PAD	DDA	8	2500	330.0	12.8	6.4	5.2	2.1	8.0	12.0	Q1
LMR23630APQDRRRQ1	WSON	DRR	12	3000	330.0	12.4	3.3	3.3	1.0	8.0	12.0	Q2
LMR23630APQDRRTQ1	WSON	DRR	12	250	180.0	12.4	3.3	3.3	1.0	8.0	12.0	Q2
LMR23630AQDDARQ1	SO Power PAD	DDA	8	2500	330.0	12.8	6.4	5.2	2.1	8.0	12.0	Q1
LMR23630FQDRRRQ1	WSON	DRR	12	3000	330.0	12.4	3.3	3.3	1.0	8.0	12.0	Q2
LMR23630FQDRRTQ1	WSON	DRR	12	250	180.0	12.4	3.3	3.3	1.0	8.0	12.0	Q2
LMR23630QDRRRQ1	WSON	DRR	12	3000	330.0	12.4	3.3	3.3	1.0	8.0	12.0	Q2
LMR23630QDRRTQ1	WSON	DRR	12	250	180.0	12.4	3.3	3.3	1.0	8.0	12.0	Q2



**TAPE AND REEL BOX DIMENSIONS**

\*All dimensions are nominal

Device	Package Type	Package Drawing	Pins	SPQ	Length (mm)	Width (mm)	Height (mm)
LMR23630AFQDDARQ1	SO PowerPAD	DDA	8	2500	366.0	364.0	50.0
LMR23630APQDRRRQ1	WSON	DRR	12	3000	367.0	367.0	38.0
LMR23630APQDRRTQ1	WSON	DRR	12	250	213.0	191.0	35.0
LMR23630AQDDARQ1	SO PowerPAD	DDA	8	2500	366.0	364.0	50.0
LMR23630FQDRRRQ1	WSON	DRR	12	3000	367.0	367.0	38.0
LMR23630FQDRRTQ1	WSON	DRR	12	250	213.0	191.0	35.0
LMR23630QDRRRQ1	WSON	DRR	12	3000	367.0	367.0	38.0
LMR23630QDRRTQ1	WSON	DRR	12	250	213.0	191.0	35.0

**TUBE**

\*All dimensions are nominal

Device	Package Name	Package Type	Pins	SPQ	L (mm)	W (mm)	T (μm)	B (mm)
LMR23630AFQDDAQ1	DDA	HSOIC	8	75	517	7.87	635	4.25
LMR23630AQDDAQ1	DDA	HSOIC	8	75	517	7.87	635	4.25

DDA (R-PDSO-G8)

PowerPAD™ PLASTIC SMALL-OUTLINE



- NOTES:
- A. All linear dimensions are in millimeters. Dimensioning and tolerancing per ASME Y14.5-1994.
  - B. This drawing is subject to change without notice.
  - C. Body dimensions do not include mold flash or protrusion not to exceed 0,15.
  - D. This package is designed to be soldered to a thermal pad on the board. Refer to Technical Brief, PowerPad Thermally Enhanced Package, Texas Instruments Literature No. SLMA002 for information regarding recommended board layout. This document is available at [www.ti.com](http://www.ti.com) <<http://www.ti.com>>.
  - E. See the additional figure in the Product Data Sheet for details regarding the exposed thermal pad features and dimensions.
  - F. This package complies to JEDEC MS-012 variation BA

PowerPAD is a trademark of Texas Instruments.

DDA (R-PDSO-G8)

PowerPAD™ PLASTIC SMALL OUTLINE

## THERMAL INFORMATION

This PowerPAD™ package incorporates an exposed thermal pad that is designed to be attached to a printed circuit board (PCB). The thermal pad must be soldered directly to the PCB. After soldering, the PCB can be used as a heatsink. In addition, through the use of thermal vias, the thermal pad can be attached directly to the appropriate copper plane shown in the electrical schematic for the device, or alternatively, can be attached to a special heatsink structure designed into the PCB. This design optimizes the heat transfer from the integrated circuit (IC).

For additional information on the PowerPAD package and how to take advantage of its heat dissipating abilities, refer to Technical Brief, PowerPAD Thermally Enhanced Package, Texas Instruments Literature No. SLMA002 and Application Brief, PowerPAD Made Easy, Texas Instruments Literature No. SLMA004. Both documents are available at [www.ti.com](http://www.ti.com).

The exposed thermal pad dimensions for this package are shown in the following illustration.



Exposed Thermal Pad Dimensions

4206322-6/L 05/12

NOTE: A. All linear dimensions are in millimeters

PowerPAD is a trademark of Texas Instruments

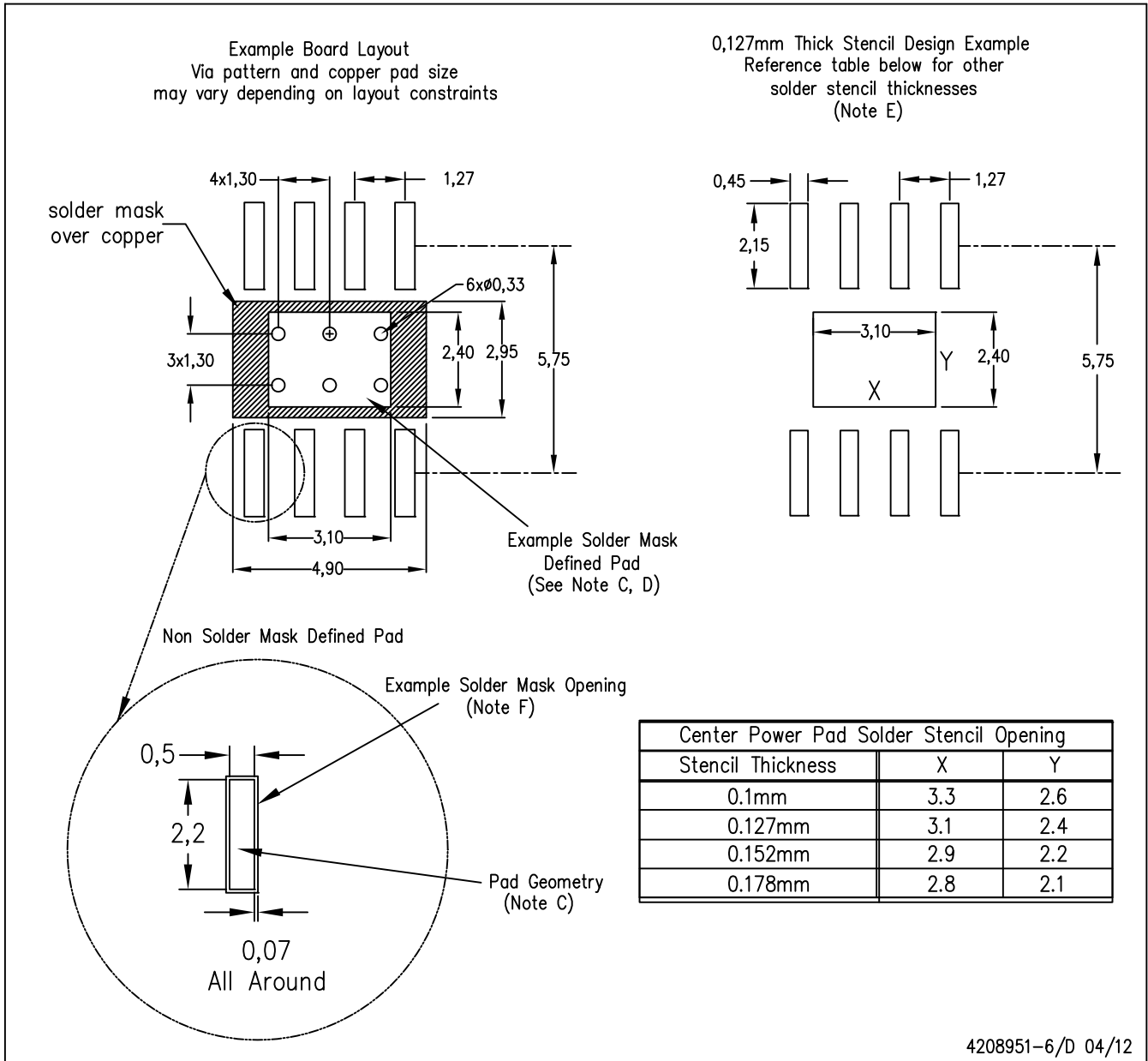

- NOTES:
- A. All linear dimensions are in millimeters.
  - B. This drawing is subject to change without notice.
  - C. Publication IPC-7351 is recommended for alternate designs.
  - D. This package is designed to be soldered to a thermal pad on the board. Refer to Technical Brief, PowerPad Thermally Enhanced Package, Texas Instruments Literature No. SLMA002, SLMA004, and also the Product Data Sheets for specific thermal information, via requirements, and recommended board layout. These documents are available at [www.ti.com](http://www.ti.com) <<http://www.ti.com>>. Publication IPC-7351 is recommended for alternate designs.
  - E. Laser cutting apertures with trapezoidal walls and also rounding corners will offer better paste release. Customers should contact their board assembly site for stencil design recommendations. Example stencil design based on a 50% volumetric metal load solder paste. Refer to IPC-7525 for other stencil recommendations.
  - F. Customers should contact their board fabrication site for solder mask tolerances between and around signal pads.

PowerPAD is a trademark of Texas Instruments.

## GENERIC PACKAGE VIEW

DRR 12

**WSO<sub>N</sub> - 0.8 mm max height**

PLASTIC SMALL OUTLINE - NO LEAD



Images above are just a representation of the package family, actual package may vary.  
Refer to the product data sheet for package details.

4223490/A

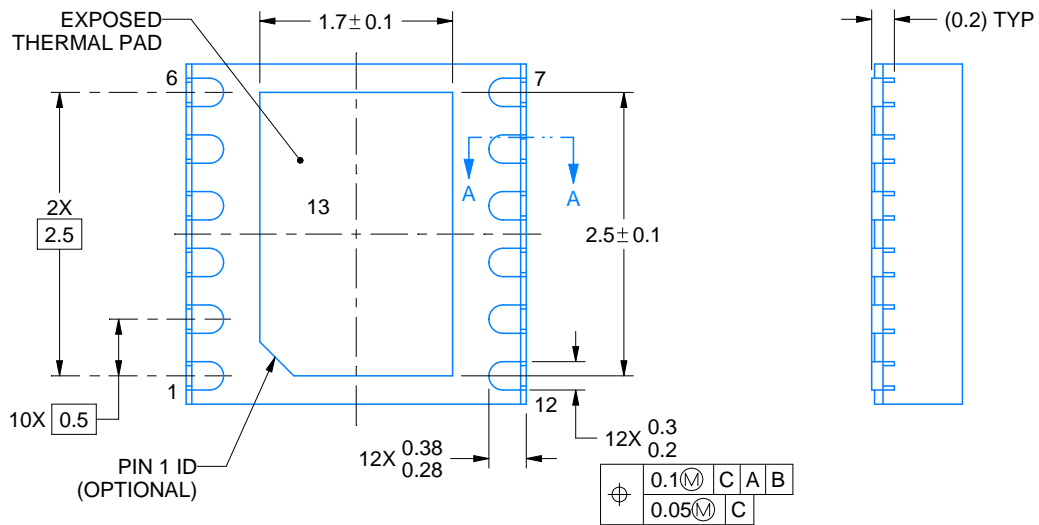
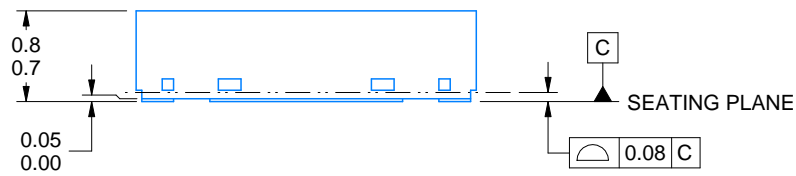
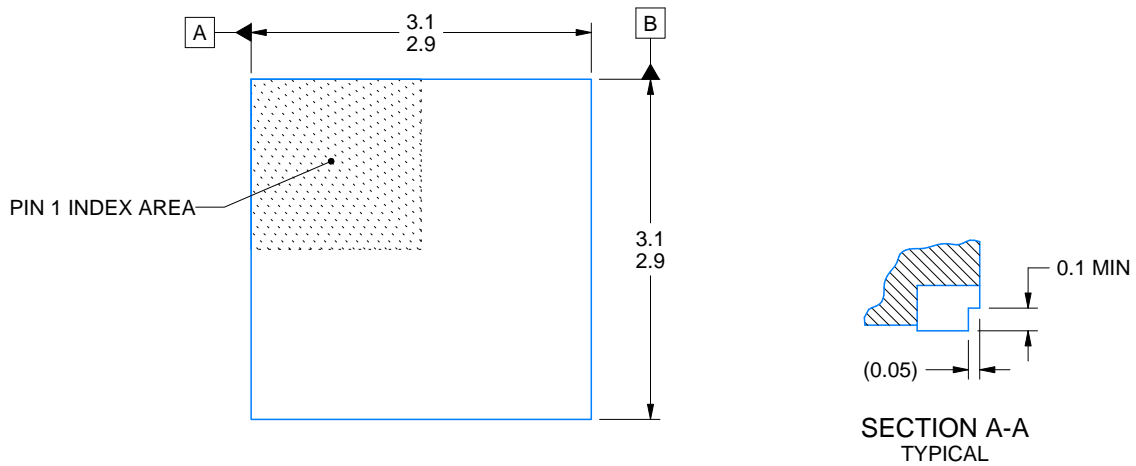

4223146/D 10/2018

NOTES:

1. All linear dimensions are in millimeters. Any dimensions in parenthesis are for reference only. Dimensioning and tolerancing per ASME Y14.5M.
2. This drawing is subject to change without notice.
3. The package thermal pad must be soldered to the printed circuit board for thermal and mechanical performance.

# EXAMPLE BOARD LAYOUT

DRR0012D

WSON - 0.8 mm max height

PLASTIC SMALL OUTLINE - NO LEAD

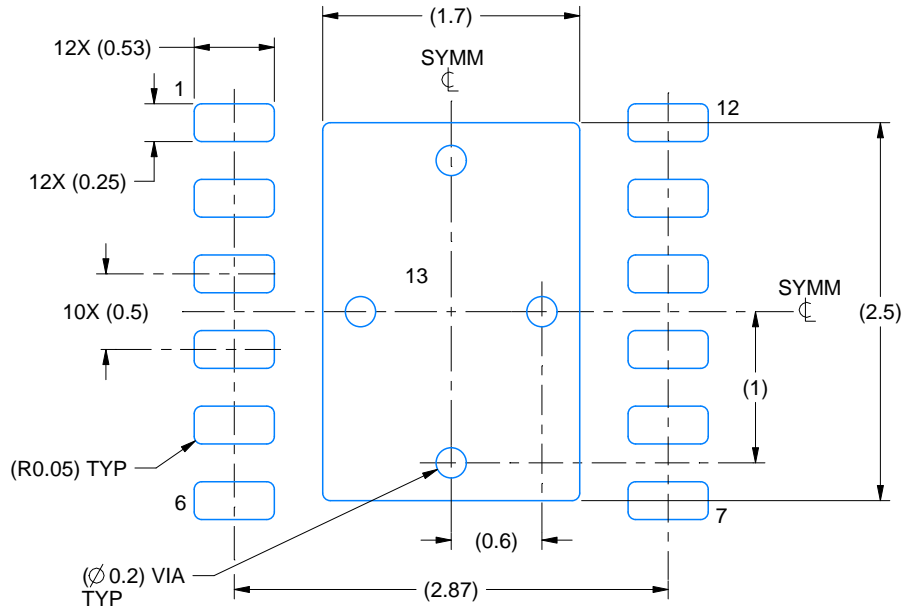

LAND PATTERN EXAMPLE  
EXPOSED METAL SHOWN  
SCALE:20X

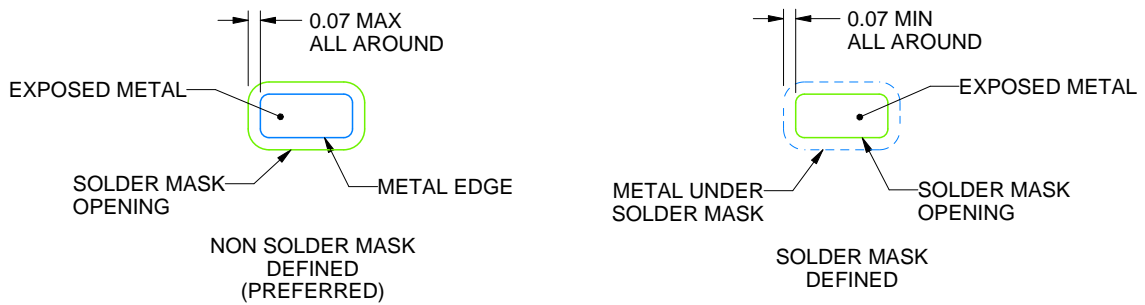

SOLDER MASK DETAILS

4223146/D 10/2018

NOTES: (continued)

4. This package is designed to be soldered to a thermal pad on the board. For more information, see Texas Instruments literature number SLUA271 ([www.ti.com/lit/slue271](http://www.ti.com/lit/slue271)).
5. Vias are optional depending on application, refer to device data sheet. If any vias are implemented, refer to their locations shown on this view. It is recommended that vias under paste be filled, plugged or tented.



# EXAMPLE STENCIL DESIGN

DRR0012D

WSON - 0.8 mm max height

PLASTIC SMALL OUTLINE - NO LEAD

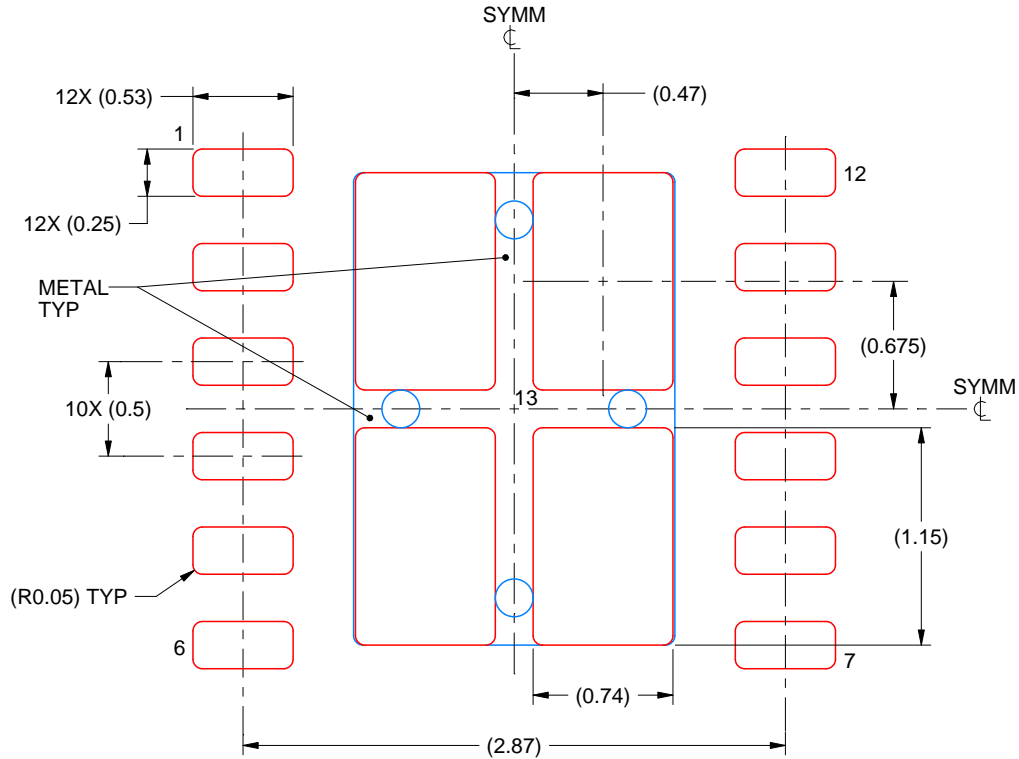

SOLDER PASTE EXAMPLE  
BASED ON 0.125 mm THICK STENCIL

EXPOSED PAD  
80.1% PRINTED SOLDER COVERAGE BY AREA  
SCALE:25X

4223146/D 10/2018

NOTES: (continued)

6. Laser cutting apertures with trapezoidal walls and rounded corners may offer better paste release. IPC-7525 may have alternate design recommendations.

## 重要声明和免责声明

TI“按原样”提供技术和可靠性数据（包括数据表）、设计资源（包括参考设计）、应用或其他设计建议、网络工具、安全信息和其他资源，不保证没有瑕疵且不做任何明示或暗示的担保，包括但不限于对适销性、某特定用途方面的适用性或不侵犯任何第三方知识产权的暗示担保。

这些资源可供使用 TI 产品进行设计的熟练开发人员使用。您将自行承担以下全部责任：(1) 针对您的应用选择合适的 TI 产品，(2) 设计、验证并测试您的应用，(3) 确保您的应用满足相应标准以及任何其他功能安全、信息安全、监管或其他要求。

这些资源如有变更，恕不另行通知。TI 授权您仅可将这些资源用于研发本资源所述的 TI 产品的应用。严禁对这些资源进行其他复制或展示。您无权使用任何其他 TI 知识产权或任何第三方知识产权。您应全额赔偿因在这些资源的使用中对 TI 及其代表造成的任何索赔、损害、成本、损失和债务，TI 对此概不负责。

TI 提供的产品受 [TI 的销售条款](#) 或 [ti.com](#) 上其他适用条款/TI 产品随附的其他适用条款的约束。TI 提供这些资源并不会扩展或以其他方式更改 TI 针对 TI 产品发布的适用的担保或担保免责声明。

TI 反对并拒绝您可能提出的任何其他或不同的条款。

邮寄地址：Texas Instruments, Post Office Box 655303, Dallas, Texas 75265

Copyright © 2022，德州仪器 (TI) 公司