

REV.	DESCRIPTION OF REVISIONS	APPR.	CHKD.	DRAW.	DATE
△	Original reversion	lucky	lucky	Roy	2020.04.06
△	Change new molding	lucky	lucky	Roy	2021.12.06

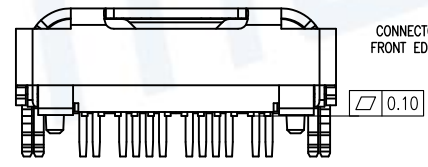

A1	GND	B12	GND
A2	SSTXP1	B11	SSRXP1
A3	SSTXN1	B10	SSRXN1
A4	VBUS	B9	VBUS
A5	CC1	B8	SBU2
A6	DP1	B7	DN2
A7	DN1	B6	DP2
A8	SBU1	B5	CC2
A9	VBUS	B4	VBUS
A10	SSRXN2	B3	SSTXN2
A11	SSRXP2	B2	SSTXP2
A12	GND	B1	GND
PIN	SIGNAL NAME	PIN	SIGNAL NAME

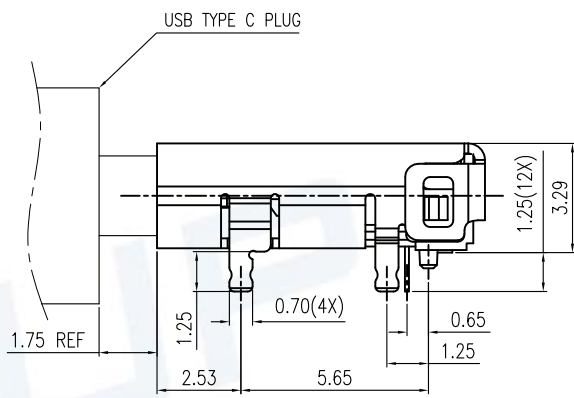
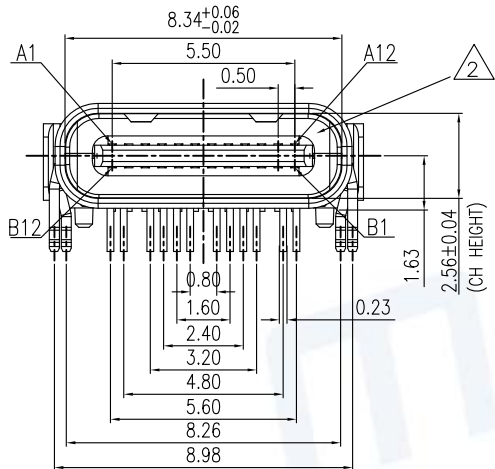
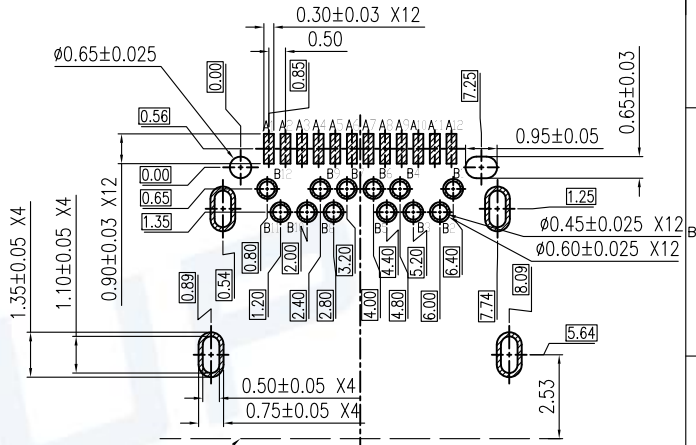
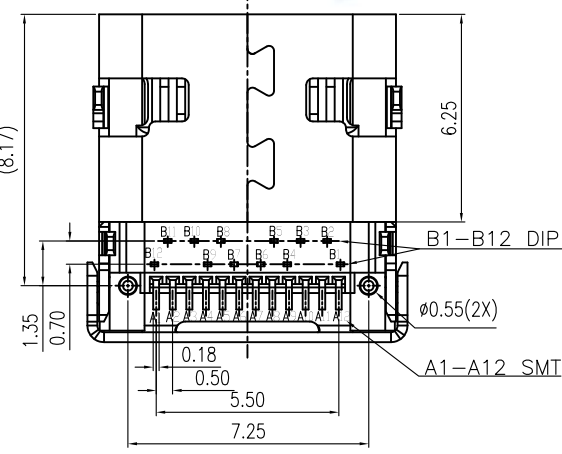

NOTE:

- MECHANICAL:
 - MATING FORCE: 0.5~2.0Kgf
 - UMMATING FORCE: Initial: 0.8~2.0Kgf
After 500 to 10,000cycles: 0.6~2.0Kgf
 - FREQUENCY: 500±50 CYCLES/HOUR, 10000 CYCLES;
- ELECTRICAL CHARACTERISTICS:
 - CURRENT RATING: 1.25A/PIN FOR FOR VBUS AND GND
0.25 A FOR OTHER PINS
 - INITIAL CONTACT RESISTANCE: 40mΩ Max.
 - INSULATION RESISTANCE: 100MΩ MIN
 - WITHSTANDING VOLTAGE: 100V AC, 1 MINUTE;
- ENVIRONMENTAL
TEMPERATURE RANGE: -40°C TO +85°C.

ITEM	PART NAME	Q'TY	MATERIAL	FINISH
1	Molding	1	THERMOPLASTIC	Black, UL94V-0
2	CONTACT	1	HIGH CONDUCTIVITY COPPER	Contact area: Gold plated over Ni.
3	SHELL	1	STAINLESS STEEL	Ni plated over all
4	MID-PLATE	1	STAINLESS STEEL	Cleaning

Unless Otherwise specified, other tolerance are:

MUP MUP INDUSTRIAL CO.,LTD.

NAME: **USB Type C Hybrid Right-Angle Receptacle**

MODEL No: **MUP-U20001-4**

TYPE : **24Pin & USB 3.1 Without GND-PLATE**

APPR. LUCKY/2021.12.06
CHKD. LUCKY/2021.12.06
DRAW. Roy/2021.12.06

PROJ. U20001-4
UNIT mm
SCALE 1:1
SHEET 1/1
REVISION 1

PRAT NO.:
DWG NO.:
DWG-U20001-4-001



REV.	DESCRIPTION OF REVISIONS	APPR.	CHKD.	DRAW.	DATE
△	Original reversion	lucky	lucky	Roy	2020.04.06
△	Change new molding	lucky	lucky	Roy	2021.12.06

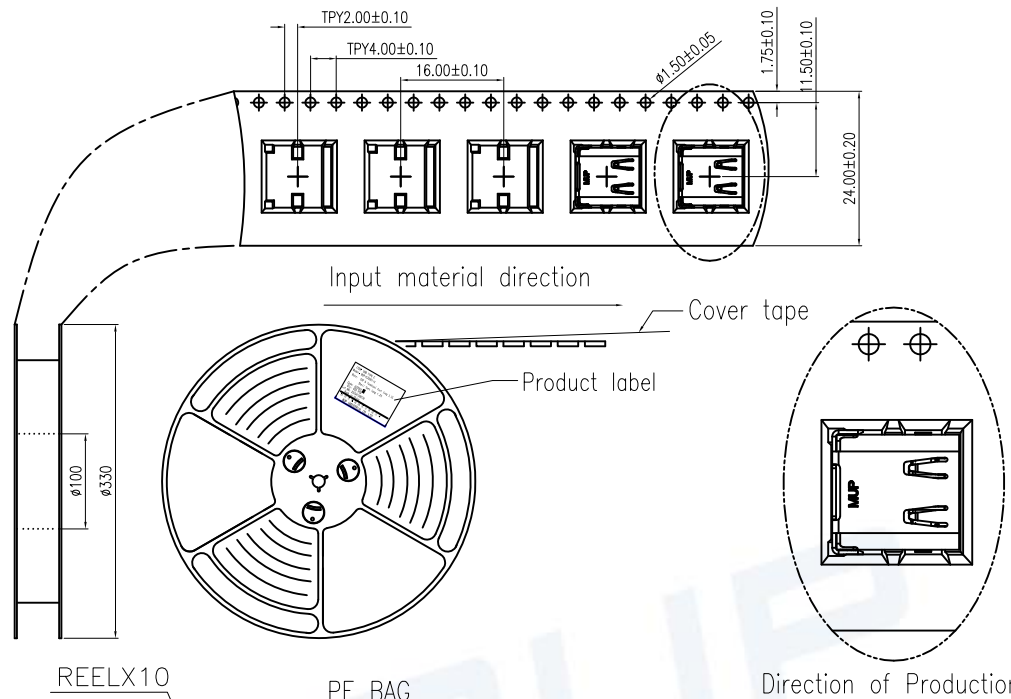

NOTES

1. NUMBER OF CONNECTORS:850PCS/REEL
2. LEAD TAPE LENGTH

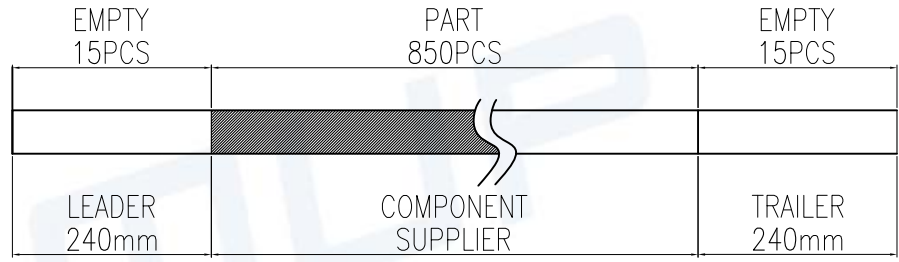

3. QUANTITY:8500/CARTON
4. WEIGHT :
 - 4.1 NET WEIGHT : 5.55 Kg
 - 4.2 GROSS WEIGHT : 9.85 Kg

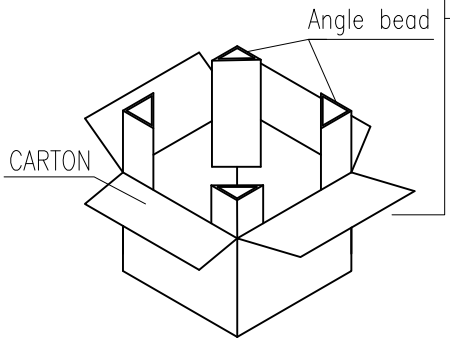
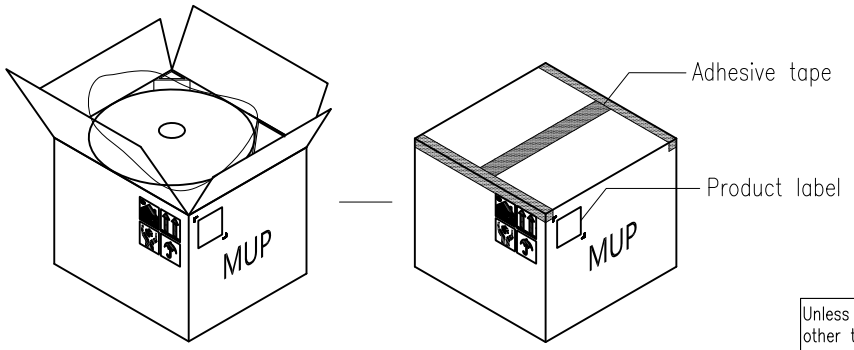
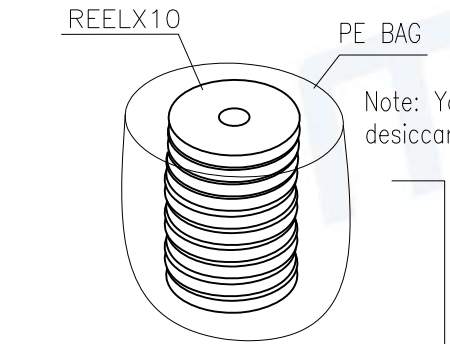

Unless Otherwise specified,
other tolerance are:

X. ±0.40	X°. ±5°
X.X ±0.30	X.X° ±4°
X.XX ±0.25	X.XX° ±3°
X.XXX±0.15	X.XXX°±2°
APPR.	LUCKY/2021.12.06
CHKD.	LUCKY/2021.12.06
DRAW.	Roy/2021.12.06

MUP MUP INDUSTRIAL CO.,LTD.			
NAME: USB Type C Hybrid Right-Angle Receptacle			
MODEL No: MUP-U20001-4			
TYPE : 24Pin & USB 3.1 Without GND-PLATE			
PRAT NO. : U20001-4		DWG NO. : DWG-U20001-4-001	
PROJ.	UNIT mm	SCALE 1:1	SHEET 2/2
			REVISION 2

