

# 产品规格书

## SPECIFICATION FOR APPROVAL

CUSTOMER/客户名称: \_\_\_\_\_

MODEL NO./产品型号: BZ-S2835WW8C1-02-3V-KMT

DESCRIPTON./产品描述: SMD 2835暖白光-0.2W-3V



DATE./日期: 2023/01/13

版本 Edition: A.1

### CUSTOMER AUTHORIZED SIGNATURE/客户承认签核

--	--	--

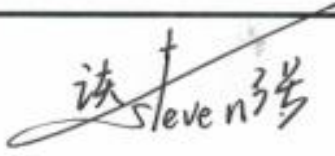
Please return to us one copy of "SPECIFICATION FOR APPROVAL" With your approved Signature./客户签字确认，盖章后请回传一份承认书我司。

核 准	审 核	制 定
		张 文 杰

Add: shenzhen baoan district rock street pond avenue macro hair tree  
Gao Xinyuan 12 5 floor of west side

地址：深圳市宝安区石岩街道塘头大道宏发佳特利高新园12栋5楼西侧

TEL/电话：0755-85255622

FAX/传真：0755-85255672

Http://www.cnbzic.com

■ Features:

1. 2.8mm\*3.5mm\*0.75mm SMD-LED
2. The material of the LED dice is InGaN
3. Extremely wide viewing angle
4. Suitable for all SMT assembly
5. ROHS compliant

■ Applications:

- Tubular light application
- Ideal for back light and indicator
- Various colors and lens types available
- Indoor and outdoor lighting
- Indoor and outdoor display

■ Outline Dimension:

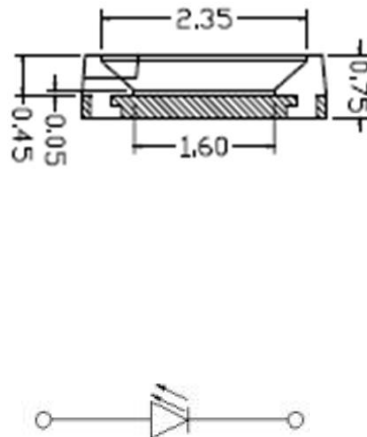
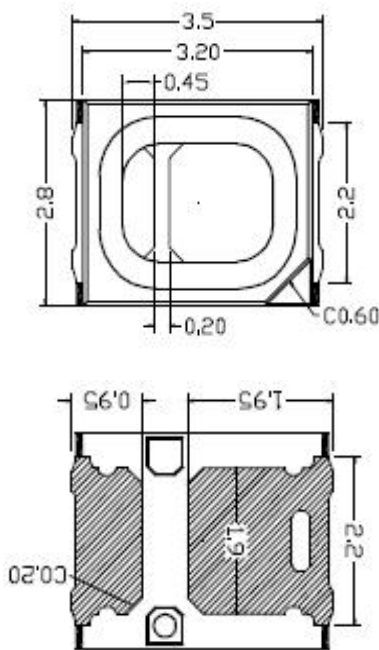

■ Recommended Soldering Pattern:

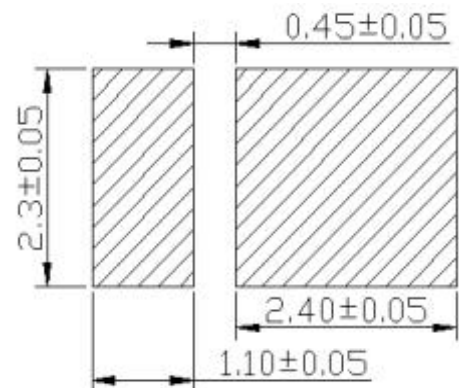

Notes:

1. All dimensions are in millimeters.
2. Tolerance is  $\pm 0.1$  unless otherwise noted.
3. Specifications are subject to change without notice.

## ■ Typical Electrical & Optical Characteristics(Ta=25° )

Items	Symbol	Condition	Min	Typ	Max	Unit
Forward Voltage	$V_F$	$I_F=60mA$	2.8		3.2	V
Reverse Current	$I_R$	$V_R=9V$	---	---	1	$\mu A$
TemperatureColor	CCT	$I_F=60mA$	2800	---	3200	K
Luminous Intensity	$I_v$	$I_F=60mA$	29	---	31	Lm
Color Rendering Index	Ra	$I_F=60mA$	---	80	---	
View Angle	$2\theta 1/2$	$I_F=60mA$	---	120	---	Deg

## ■ Absolute Maximum Ratings (Ta = 25°C)

Items	Symbol	Absolute maximum Rating	Unit
Power Dissipation	PD	200	mW
Forward Current(DC)	$I_F$	60	mA
Peak Pulse Current [1]	$I_{FP}$	100	mA
Reverse Voltage	$V_R$	5	V
Electrostatic Discharge	ESD	2000 (HBM)	V
Operation Temperature	Topr	- 40~ + 85	°C
Storage Temperature	Tstg	- 40~ + 100	°C

Note :1/10 Duty Cycle, 0.1 ms Pulse Width

■ Typical optical characteristics curves

1、Current and Voltage

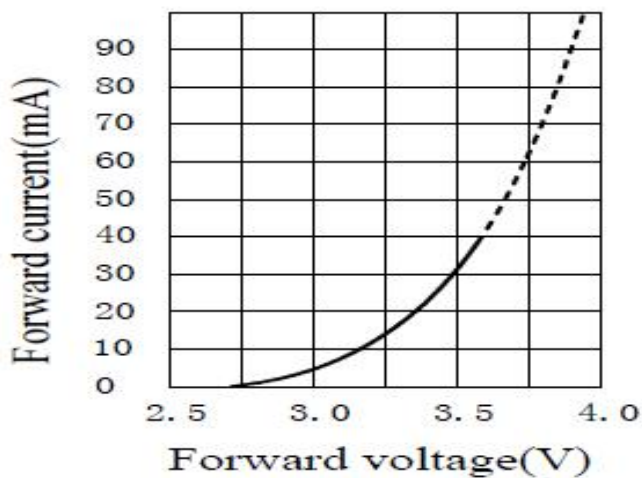

2、Forward current and the relative strength

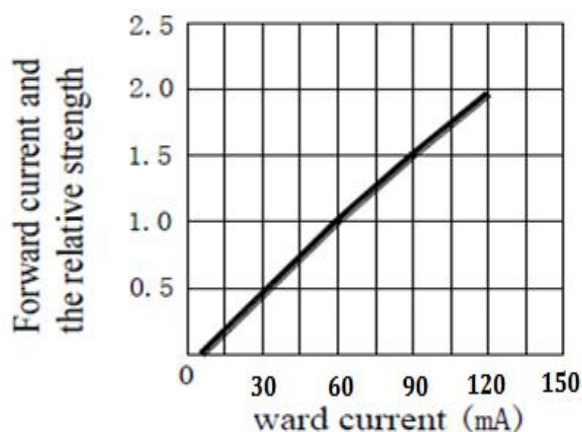

3、Ambient temperature and forward current

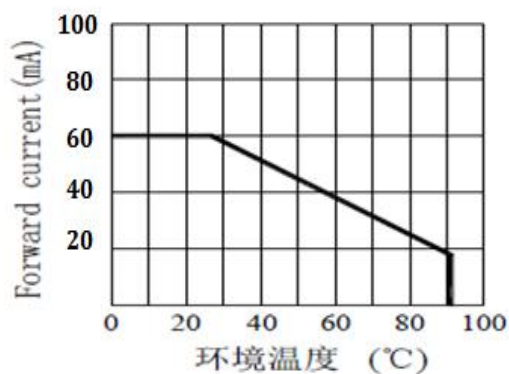

4、Ambient temperature and relative strength

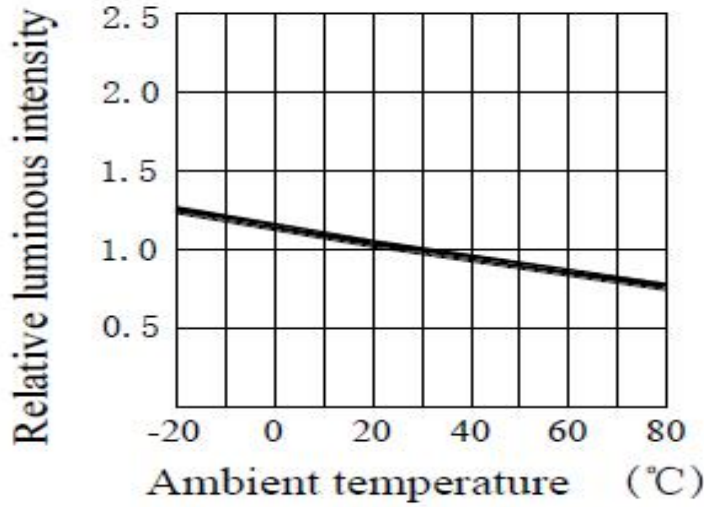

5、Typical representative Spatial Radiation Pattern

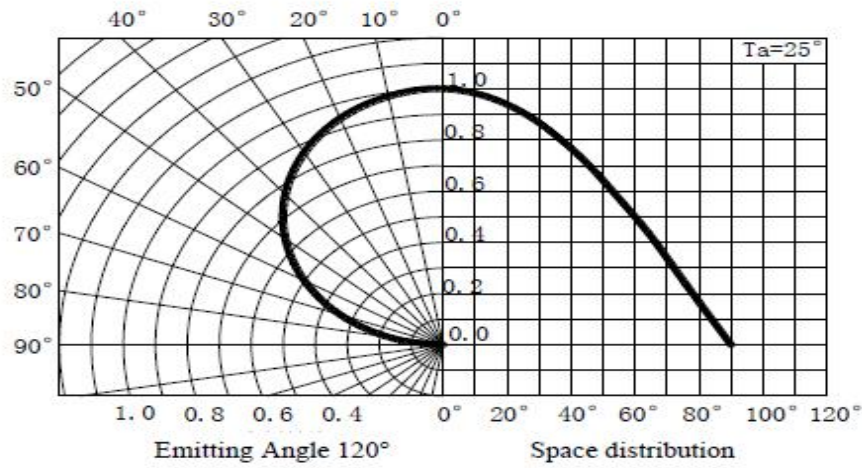

6、Typical Electrical / Optical Characteristics Curves

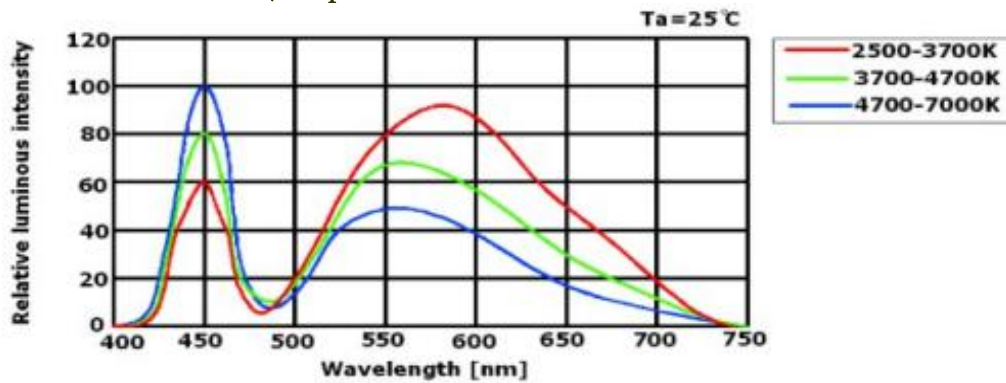

## ■ Reliability Test

Number	Test Item	Test Conditions	Sample size	Acceptance/Rejection
1	Reflow Solder	Temperature: Max 260 °C Time: 10S Cycles : 3times	50PCS	0/1
2	Life Test	Temperature=25 °C ± 5 °C Current=60mA ± 2mA Cycles: 10000H	50PCS	0/1
3	Temperature Cycling	85°C ~ 25°C ~ -40°C ~ 25°C 30min 5min 30min 5min Cycles: 100	50PCS	0/1
4	Hot/cold Temperature Shock	100 °C ± 5 °C ~ -40 °C ± 5 °C 15 mins 15 mins Cycles: 100	50PCS	0/1
5	Low Temperature Storage	Temperature: -40 °C ± 5 °C Cycles: 1000H	50PCS	0/1
6	High Temperature Storage	Temperature: 100 °C ± 5 °C Cycles: 1000H	50PCS	0/1

Remarks: Specifications are subject to change without prior notice.

## ■ Reflow soldering instructions

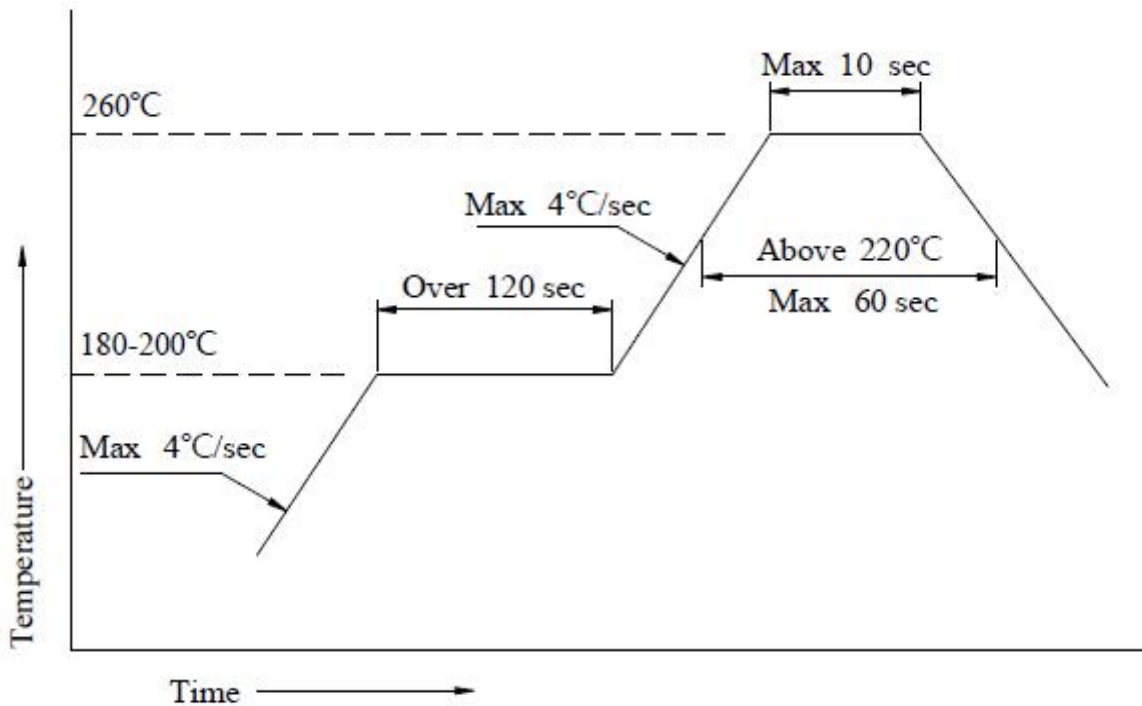

- 1、Reflow soldering is recommended to the use of clean free flux, and in accordance to the reflow curve. Maximum number of soldering is limited
- 2、When soldering, do not exert pressure during heating process.

## ■ Soldering

- 1、When manual soldering iron is used, it is recommended to use 20W anti-electro static soldering iron, soldering temperature must be kept below  $360^{\circ}\text{C}$  / 3 seconds, 1Time soldering only
- 2、Do not mix different BIN materials on the same board, otherwise it will cause LED color Variation

■ Taping Specifications (Unit: mm)

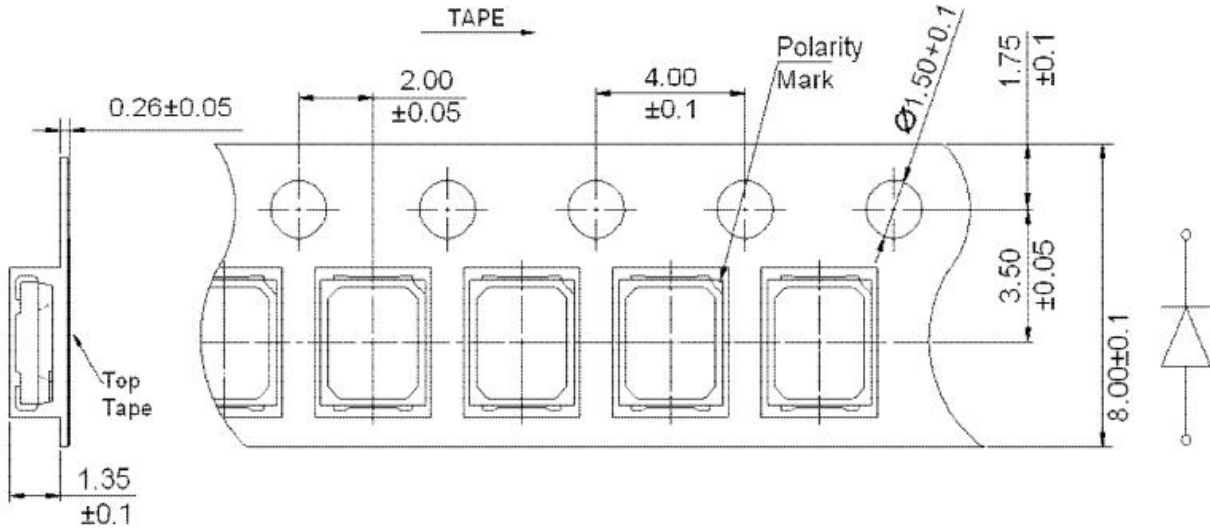

■ Reel Size (Unit: mm)

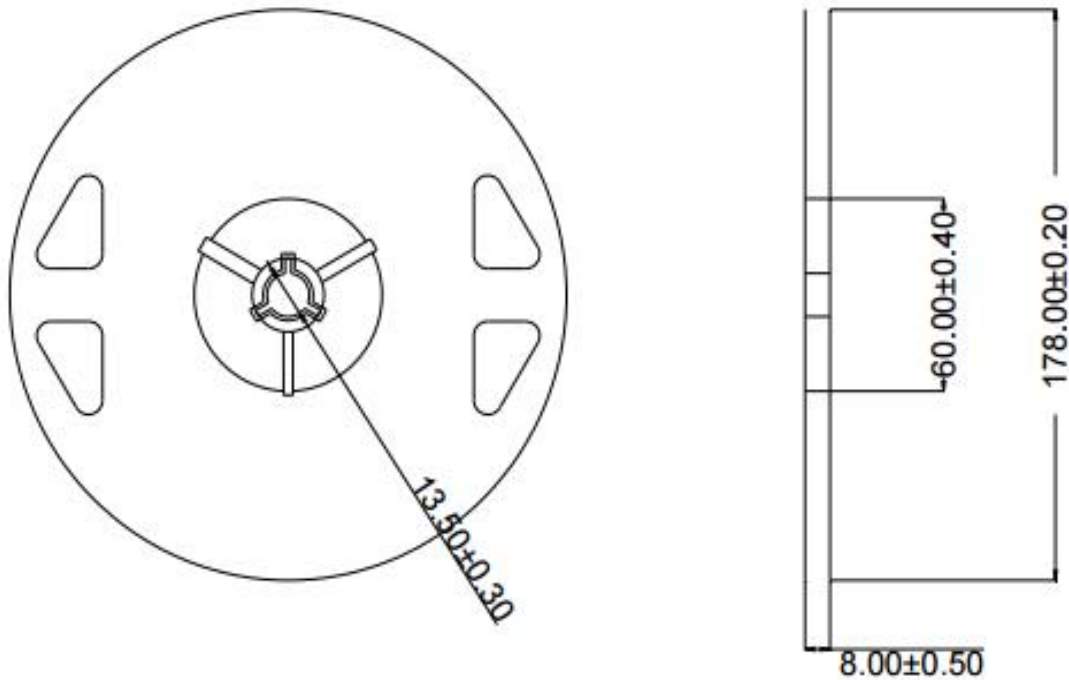



■ Humidity Proof packaging

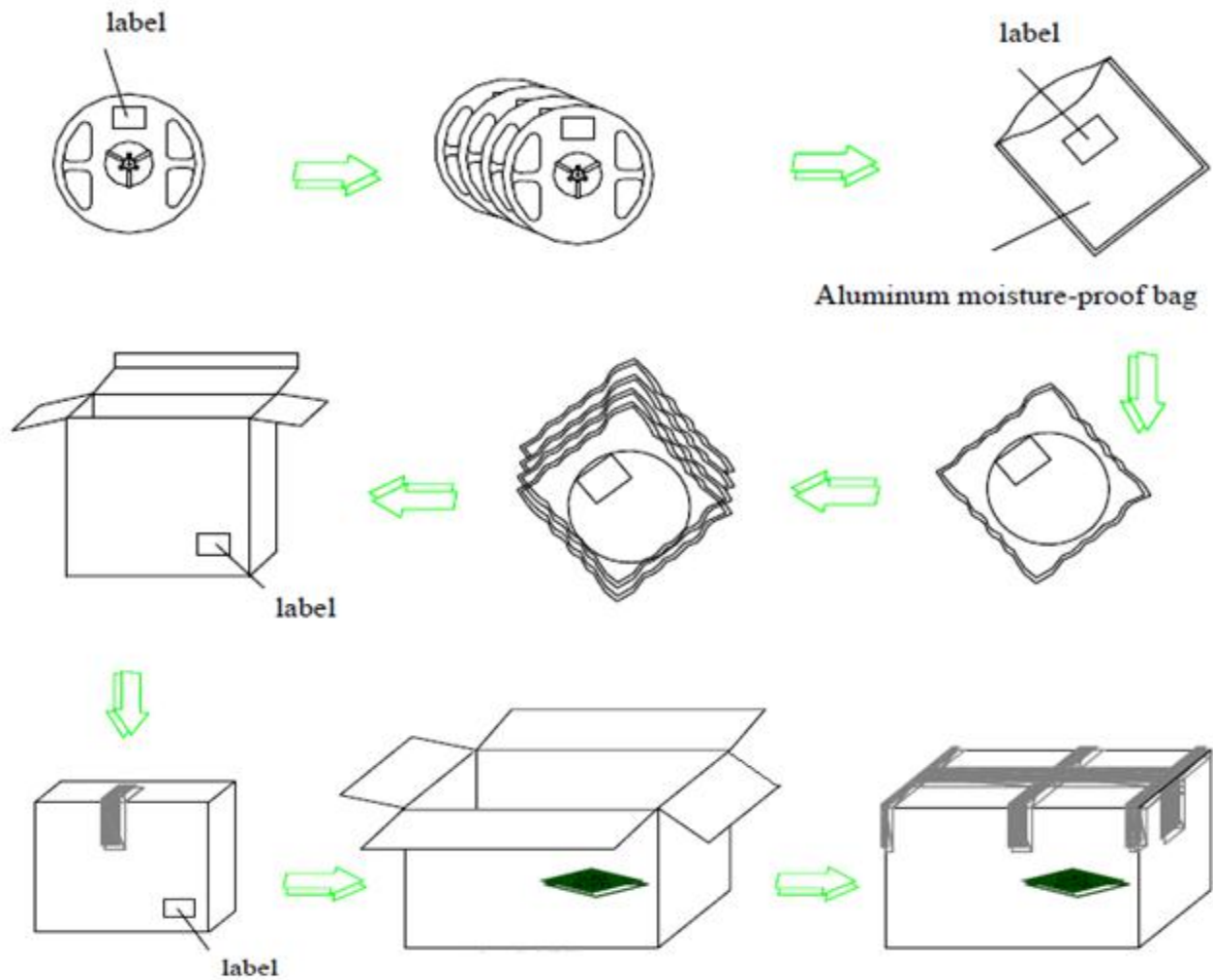

Note:

Pressure affects the reliability of light emitting diodes. In such circumstances, the assembly of organic silicon encapsulated LED products must comply with the appropriate measures to deal with. Avoid any pressure applied to any part of the LED and use pneumatic nozzle. Otherwise it may lead to reduction in reliability, and impact of its life to the LED