

NOTES: 1.MATERIAL:
MOLDING: LCP UL94 V-0
CONTACT: COPPER ALLOY,
PLATED GOLD ON CONTACT AREA,
G/F GOLD ON SOLDER AREA,
50u" NICKEL PLATING OVER ALL.
SHELL: SUS304-H,T=0.30±0.03mm
50u" NICKEL PLATING OVER ALL.
SHILD: SUS304-H,T=0.12±0.03mm
2.MECHANICAL:
INSERTION: 5~20N.
EXTRACTION: 8~20N.
DURABILITY: 10000 CYCLES
3.ELECTRICAL:
CURRENT: 5A MAX FOR VBUS;
1.25A FOR GND, 0.25A FOR OTHER OTHER.
VOLTAGE: 20VDC MAX
WITHSTANDING VOLTAGE: 100V AC.
CONTACT RESISTANCE: 40mΩ MAX.
INSULATION RESISTANCE: 100MΩ MIN.
4.ENVIRONMENTAL
TEMPERATURE RANGE: -30°C TO +80°C

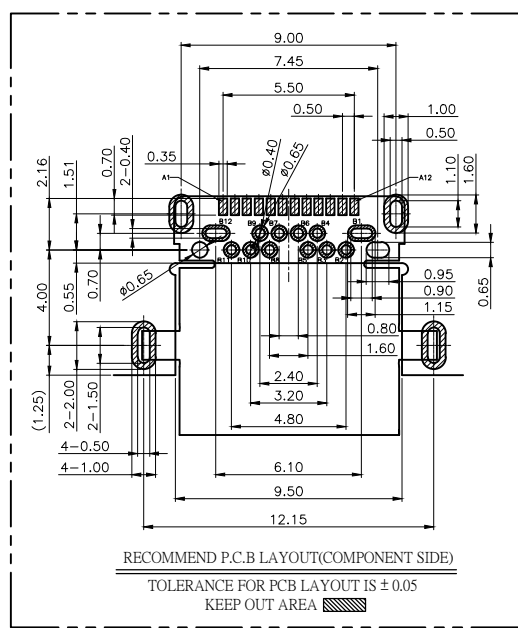

USB TYPE-C PIN ASSIGNMENTS			
PIN NUMBER	SIGNAL NAME	PIN NUMBER	SIGNAL NAME
A1	GND	B12	GND
A2	SSTXP1	B11	SSRXP1
A3	SSTXN1	B10	SSRXN1
A4	VBUS	B9	VBUS
A5	CC1	B8	SBU2
A6	Dp1	B7	Dn2
A7	Dn1	B6	Dp2
A8	SBU1	B5	CC2
A9	VBUS	B4	VBUS
A10	SSRXN2	B3	SSTXN2
A11	SSRXP2	B2	SSTXP2
A12	GND	B1	GND

P/N	L	B	COLOR	額定電流
HC-TYPE-C-24P-DS8, 65-MMO, 33-5A-04	8.65mm	4.85mm	黑色	5A
HC-TYPE-C-24P-DS10, 0-MMO, 33-5A-04	10.00mm	6.20mm	黑色	5A

Ordering Information

HC-TYPE-C - 24P - *** - *** - *A - F* - * - 04

Pin 4P, 8P, 12P, 16P, 24P
Type: TM-Top Mount (R, L), DS-DSIP (R, L), MM-MM Mount (R, L), CS-Center Height (R, L), VS-Vertical Stiff (R, L), DP-DP (R, L), FL-Flange (R, L)
Current: 5A
Foot Length: 3A
Colour: BK-Black, WH-White, BU-Blue, GR-Green, OR-Orange, PU-Purple, YE-Yellow

			GENREL TOLERANCE	制图 DRAWING	深圳市华灿天禄电子有限公司 ShenzhenhuacantianluELECTRONICS CO., LTD			
			DIM TOL	审核 CHECK	产品名称 TITLE	TYPE CF 24P 前插后贴+沉板 CH0.33 L8.65/10.00mm 带柱无弹	版本 REV.	A
			X.X ±0.30	批准 APPROVAL	产品料号 PART NO.	HC-TYPE-C-24P-DSX-MMO.33-5A-04	单位 UNITS	mm
			X.XX ±0.20	比例 SCALE	材料 MATERIAL		页次 SHEET	1/2
			X.XXX ±0.10	投影 Projection				
序号 No.	变更内容 MODIFY CONTENT	日期 MODIFY DATE	Angle ±3.0°					

pcs/box	boxes/Carton	Pcs/Box
1000	10	10000

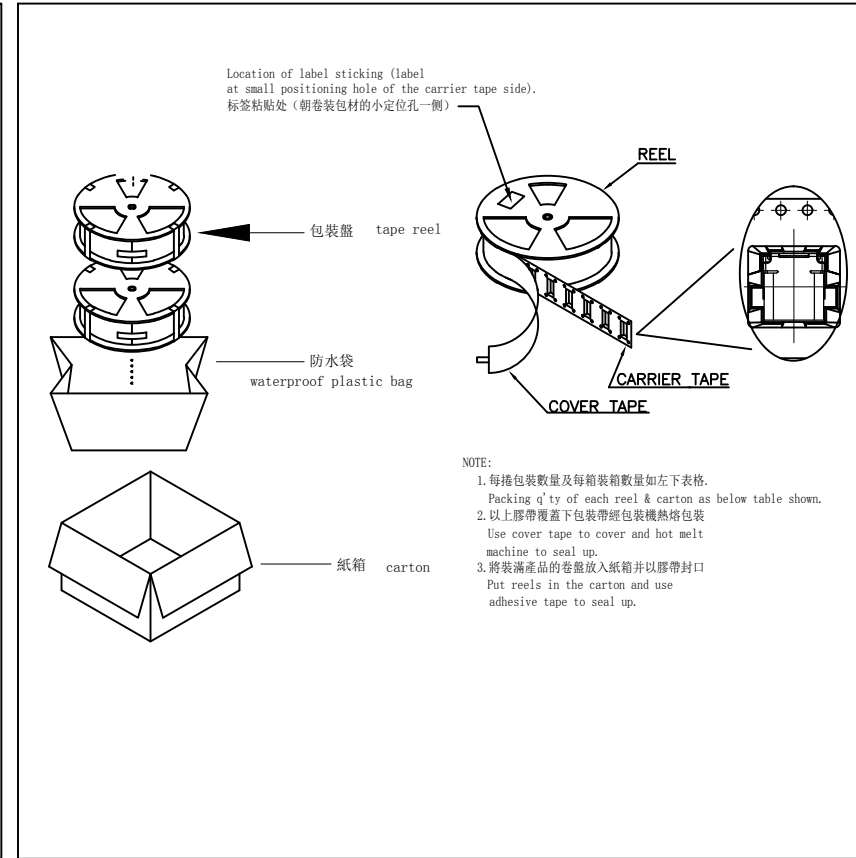
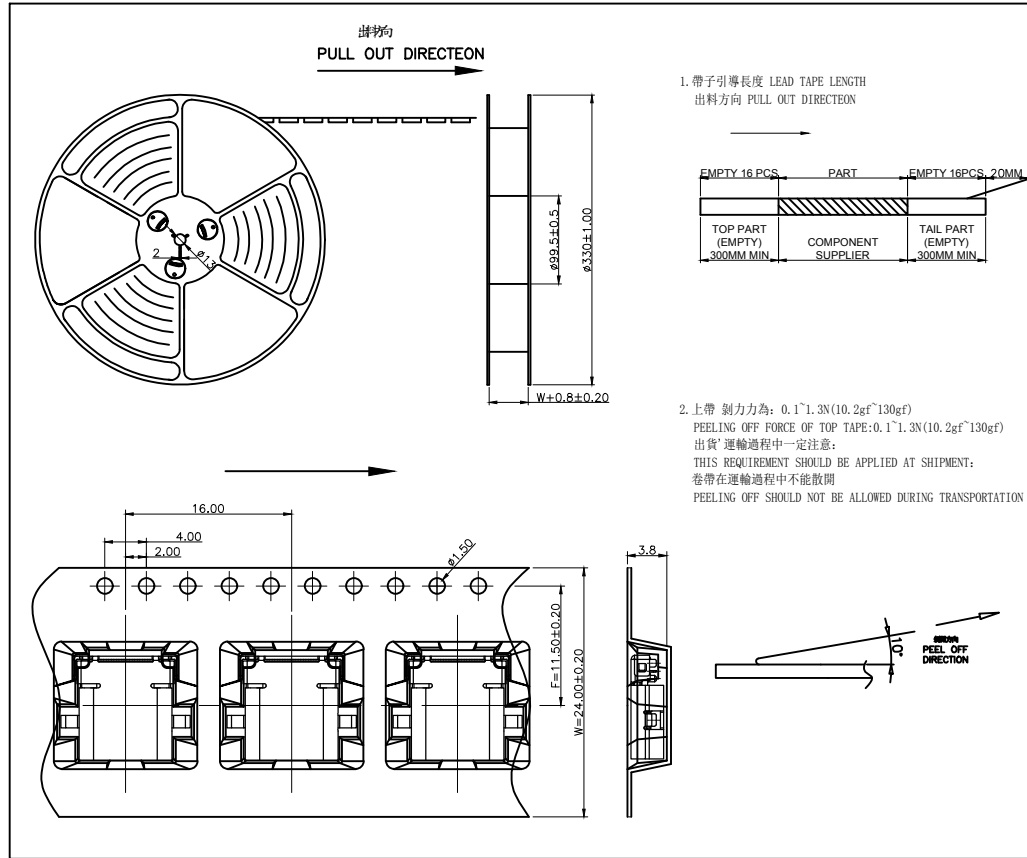

			GENREL TOLERANCE		制 圖 DRAWING		 深圳市华灿天禄电子有限公司 ShenzhenhuacantianluELECTRONICS CO.,LTD			
			DIM	TOL	审 核 CHECK					
			X.X	±0.30	批 准 APPROVAL		产品名称 TITLE	TYPE CF 24P 前插后贴+沉板 CH0.33 L8.65/10.00mm 带柱无弹 -包装图	版本 REV.	A
			X.XX	±0.20	比 例 SCALE		产品料号 PART NO.	HC-TYPE-C-24P-DSX-MM0.33-5A-04	单 位 UNITS	mm
			X.XXX	±0.10	投 影 Projection		材 料 MATERIAL		页 次 SHEET	2/2
序号 No.	变更内容 MODIFY CONTENT	日期 MODIFY DATE	Angle ±3.0°		