

100mA TinyPower LDO

Features

- Low power consumption
- Low voltage drop
- Low temperature coefficient
- High input voltage (up to 30V)
- Quiescent current 1 μ A
- High output current : 100mA
- Output voltage accuracy: tolerance $\pm 2\%$
- TO92, SOT89 and SOT23-5 packages

Applications

- Battery-powered equipment
- Communication equipment
- Audio/Video equipment

General Description

The SK75xx-3 series is a set of three-terminal low power high voltage implemented in CMOS technology. They can deliver 100mA output current and allow an input voltage as high as 24V. They are available with several fixed output voltages ranging from 2.1V to 12.0V. CMOS technology ensures low voltage drop and low quiescent current.

Although designed primarily as fixed voltage regulators, these devices can be used with external components to obtain variable voltages and currents.

Pin Descriptions

Pin No.		Pin Name	Pin Description
TO-92	SOT89-3		
1	1	GND	Ground pin
2	2	VIN	Input pin
3	3	VOUT	Output pin

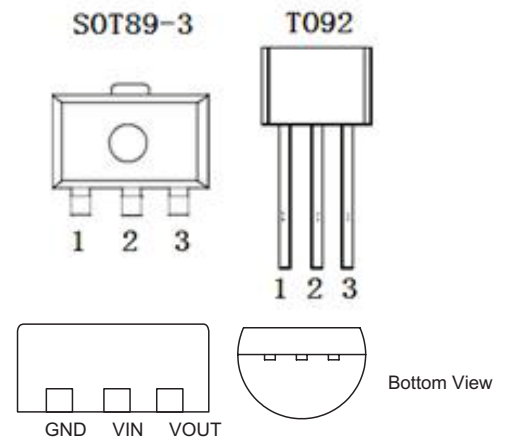

Model selection

NO.	Model	Input Voltage	Output Voltage	Tolerance	Package
SK75XX-1	7530-1	24V	3.0V	$\pm 3\%$	TO 92 SOT89-3
	7533-1	24V	3.3V	$\pm 3\%$	
	7536-1	24V	3.6V	$\pm 3\%$	
	7544-1	24V	4.4V	$\pm 3\%$	
	7550-1	24V	5.0V	$\pm 3\%$	

■ Block Diagram

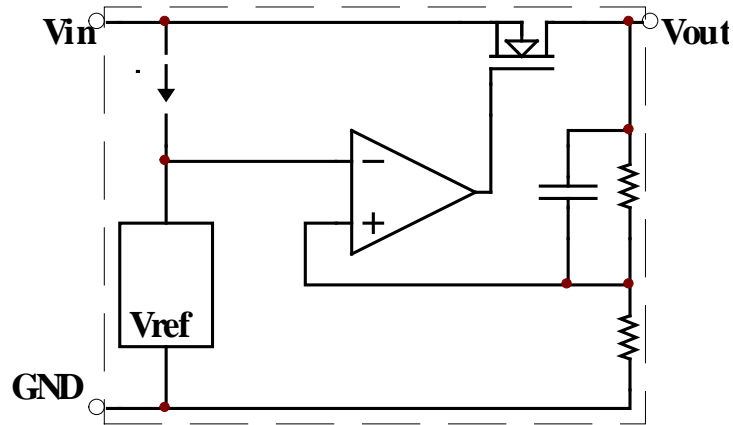

Absolute Maximum Ratings

Supply Voltage -0.3V to 33V

Operating Temperature -40°C to 85°C

Storage Temperature -50°C to 125°C

Thermal Information

Symbol	Parameter	Package	Max.	Unit
θ_{JA}	Thermal Resistance (Junction to Ambient) (Assume no ambient airflow, no heat sink)	SOT23-5	500	°C/W
		SOT89	200	°C/W
		TO92	200	°C/W
P_D	Power Dissipation	SOT23-5	0.20	W
		SOT89	0.50	W
		TO92	0.50	W

Note: P_D is measured at $T_a=25^\circ\text{C}$

■ Electrical Characteristics

SK7530-1

 $T_{OPT}=25^{\circ}\text{C}$

Symbol	Parameter	Test Conditions	Min.	Typ.	Max.	Unit
		Conditions				
V_{IN}	Input Voltage	—	—	—	24	V
V_{OUT}	Output Voltage	$V_{IN}=5.0\text{V}$, $I_{OUT}=10\text{mA}$	2.910	3.000	3.090	V
I_{OUT}	Output Current	$V_{IN}=5.0\text{V}$	60	100	—	mA
ΔV_{OUT}	Load Regulation	$V_{IN}=5.0\text{V}$, $1\text{mA}\leq I_{OUT}\leq 20\text{mA}$	—	100	150	mV
V_{DIF}	Dropout Voltage ^(Note)	$I_{OUT}=1\text{mA}$,	—	30	100	mV
I_{SS}	Quiescent Current	No load	—	2.0	3.0	μA
$\frac{\Delta V_{OUT}}{\Delta V_{IN} \times V_{OUT}}$	Line Regulation	$4.0\text{V}\leq V_{IN}\leq 24\text{V}$, $I_{OUT}=1\text{mA}$	—	—	0.2	%/V
$\frac{\Delta V_{OUT}}{\Delta T_a \times V_{OUT}}$	Temperature Coefficient	$I_{OUT}=10\text{mA}$, $-40^{\circ}\text{C}<T_a<85^{\circ}\text{C}$	—	100	—	ppm/ $^{\circ}\text{C}$

SK7533-1

 $T_{OPT}=25^{\circ}\text{C}$

Symbol	Parameter	Test Conditions	Min.	Typ.	Max.	Unit
		Conditions				
V_{IN}	Input Voltage	—	—	—	24	V
V_{OUT}	Output Voltage	$V_{IN}=5.5\text{V}$, $I_{OUT}=10\text{mA}$	3.201	3.300	3.399	V
I_{OUT}	Output Current	$V_{IN}=5.5\text{V}$	60	100	—	mA
ΔV_{OUT}	Load Regulation	$V_{IN}=5.5\text{V}$, $1\text{mA}\leq I_{OUT}\leq 30\text{mA}$	—	100	150	mV
V_{DIF}	Dropout Voltage ^(Note)	$I_{OUT}=1\text{mA}$	—	100	—	mV
I_{SS}	Quiescent Current	No load	—	2.0	3.0	μA
$\frac{\Delta V_{OUT}}{\Delta V_{IN} \times V_{OUT}}$	Line Regulation	$4.3\text{V}\leq V_{IN}\leq 30\text{V}$, $I_{OUT}=1\text{mA}$	—	—	0.2	%/V
$\frac{\Delta V_{OUT}}{\Delta T_a \times V_{OUT}}$	Temperature Coefficient	$I_{OUT}=10\text{mA}$, $-40^{\circ}\text{C}<T_a<85^{\circ}\text{C}$	—	100	—	ppm/ $^{\circ}\text{C}$

SK7536-1

$T_{OPT}=25^{\circ}\text{C}$

Symbol	Parameter	Test Conditions	Min.	Typ.	Max.	Unit
		Conditions				
V_{IN}	Input Voltage	—	—	—	24	V
V_{OUT}	Output Voltage	$V_{IN}=5.6\text{V}, I_{OUT}=10\text{mA}$	3.492	3.600	3.708	V
I_{OUT}	Output Current	$V_{IN}=5.6\text{V}$	60	100	—	mA
ΔV_{OUT}	Load Regulation	$V_{IN}=5.6\text{V}, 1\text{mA}\leq I_{OUT}\leq 30\text{mA}$	—	100	150	mV
V_{DIF}	Dropout Voltage ^(Note)	$I_{OUT}=1\text{mA}$	—	100	—	mV
I_{SS}	Quiescent Current	No load	—	2.0	3.0	μA
$\frac{\Delta V_{OUT}}{\Delta V_{IN} \times V_{OUT}}$	Line Regulation	$4.6\text{V}\leq V_{IN}\leq 30\text{V}, I_{OUT}=1\text{mA}$	—	—	0.2	%/V
$\frac{\Delta V_{OUT}}{\Delta T_a \times V_{OUT}}$	Temperature Coefficient	$I_{OUT}=10\text{mA}, -40^{\circ}\text{C}<T_a<85^{\circ}\text{C}$	—	100	—	ppm/ $^{\circ}\text{C}$

SK7544-1

$T_{Ta}=25^{\circ}\text{C}$

Symbol	Parameter	Test Conditions	Min.	Typ.	Max.	Unit
		Conditions				
V_{IN}	Input Voltage	—	—	—	24	V
V_{OUT}	Output Voltage	$V_{IN}=6.4\text{V}, I_{OUT}=10\text{mA}$	4.268	4.400	4.532	V
I_{OUT}	Output Current	$V_{IN}=6.4\text{V}$	60	100	—	mA
ΔV_{OUT}	Load Regulation	$V_{IN}=6.4\text{V}, 1\text{mA}\leq I_{OUT}\leq 30\text{mA}$	—	100	150	mV
V_{DIF}	Dropout Voltage ^(Note)	$I_{OUT}=1\text{mA}$	—	100	—	mV
I_{SS}	Quiescent Current	No load	—	2.0	3.0	μA
$\frac{\Delta V_{OUT}}{\Delta V_{IN} \times V_{OUT}}$	Line Regulation	$5.4\text{V}\leq V_{IN}\leq 30\text{V}, I_{OUT}=1\text{mA}$	—	—	0.2	%/V
$\frac{\Delta V_{OUT}}{\Delta T_a \times V_{OUT}}$	Temperature Coefficient	$I_{OUT}=10\text{mA}, -40^{\circ}\text{C}<T_a<85^{\circ}\text{C}$	—	100	—	ppm/ $^{\circ}\text{C}$

SK7550-1

$T_{OPT}=25^{\circ}C$

Symbol	Parameter	Test Conditions	Min.	Typ.	Max.	Unit
		Conditions				
V_{IN}	Input Voltage	—	—	—	24	V
V_{OUT}	Output Voltage	$V_{IN}=7.0V, I_{OUT}=10mA$	4.850	5.000	5.150	V
I_{OUT}	Output Current	$V_{IN}=7.0V$	60	100	—	mA
ΔV_{OUT}	Load Regulation	$V_{IN}=7.0V, 1mA \leq I_{OUT} \leq 30mA$	—	100	—	mV
V_{DIF}	Dropout Voltage ^(Note)	$I_{OUT}=1mA$	—	100	—	mV
I_{SS}	Quiescent Current	No load	—	2.0	3.0	μA
$\frac{\Delta V_{OUT}}{\Delta V_{IN} \times V_{OUT}}$	Line Regulation	$6.0V \leq V_{IN} \leq 30V, I_{OUT}=1mA$	—	—	0.2	%/V
$\frac{\Delta V_{OUT}}{\Delta T_a \times V_{OUT}}$	Temperature Coefficient	$I_{OUT}=10mA, -40^{\circ}C < T_a < 85^{\circ}C$	—	100	—	ppm/ $^{\circ}C$

Application Circuits

Basic Circuit

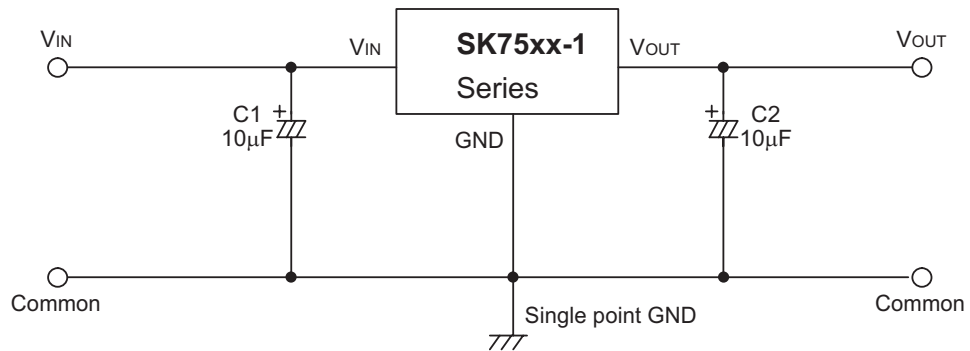

High Output Current Positive Voltage Regulator

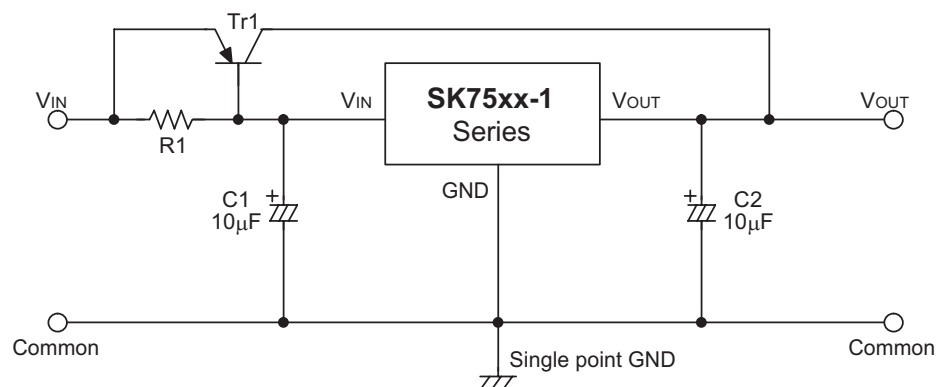

Short-Circuit Protection for Tr1

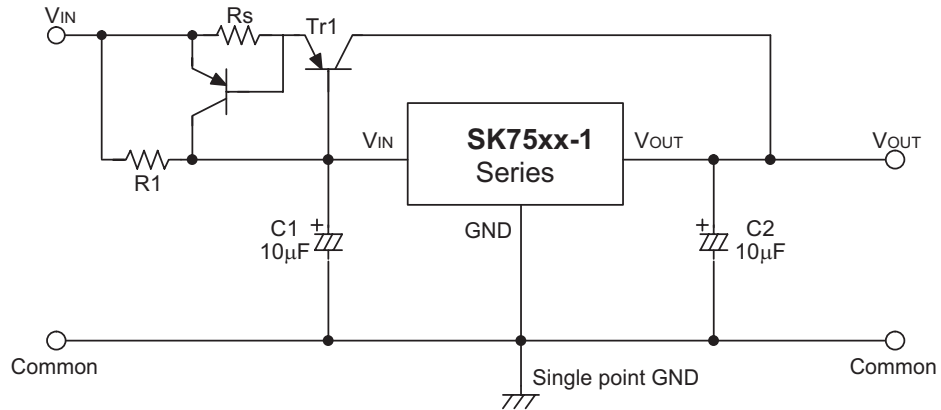

Circuit for Increasing Output Voltage

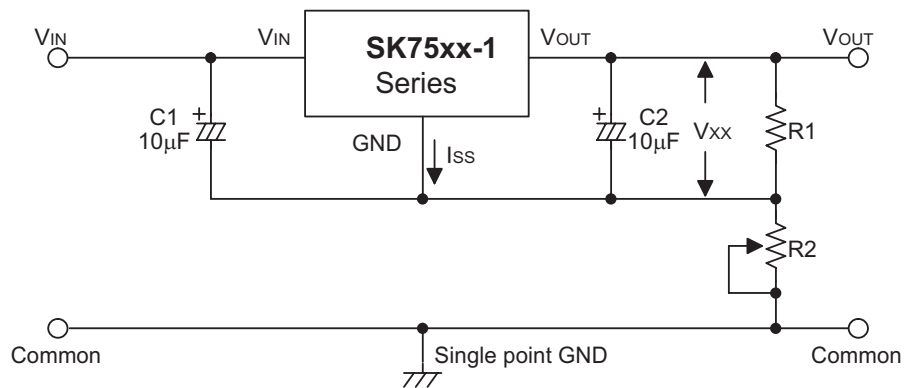

$$V_{OUT} = V_{XX} (1 + R_2/R_1) + I_{SS} \times R_2$$

Circuit for Increasing Output Voltage

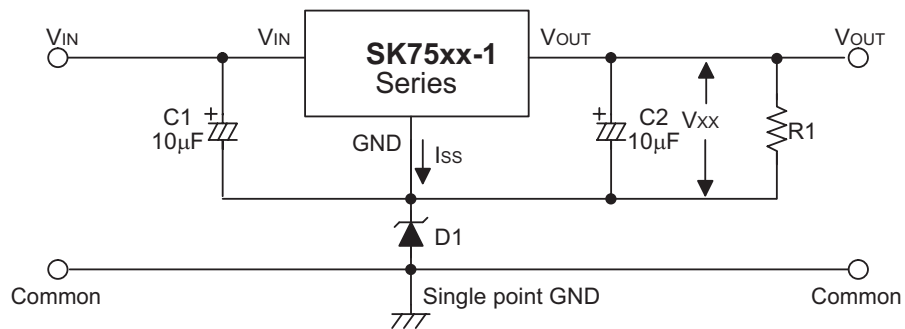

$$V_{OUT} = V_{XX} + V_{D1}$$

Constant Current Regulator

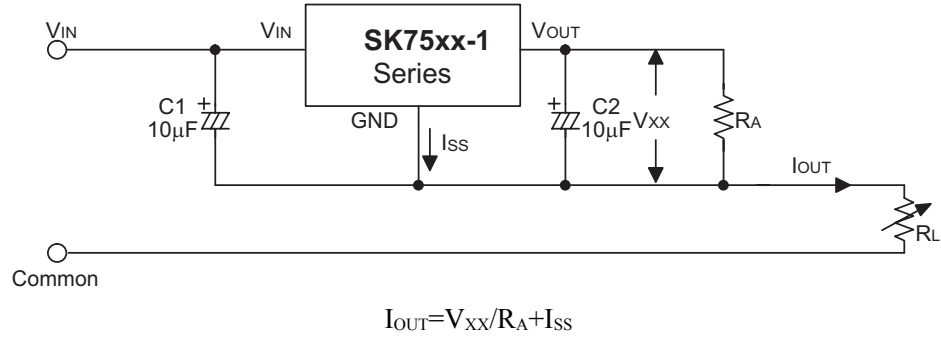

Dual Supply

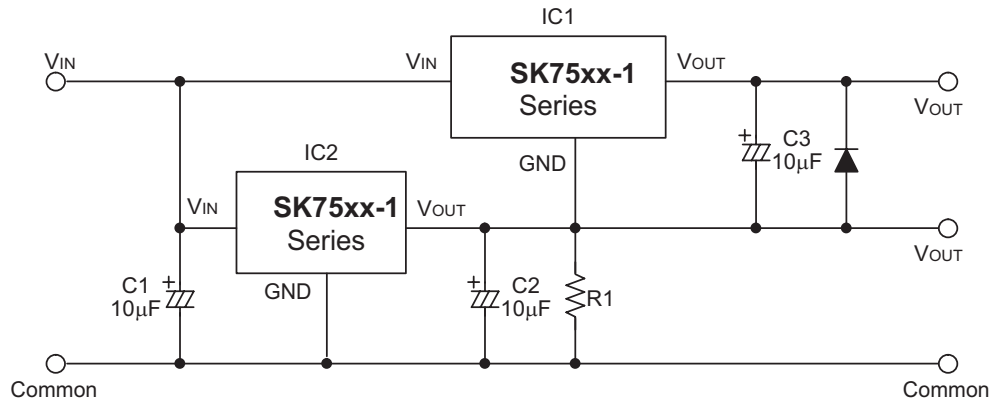

T0-92

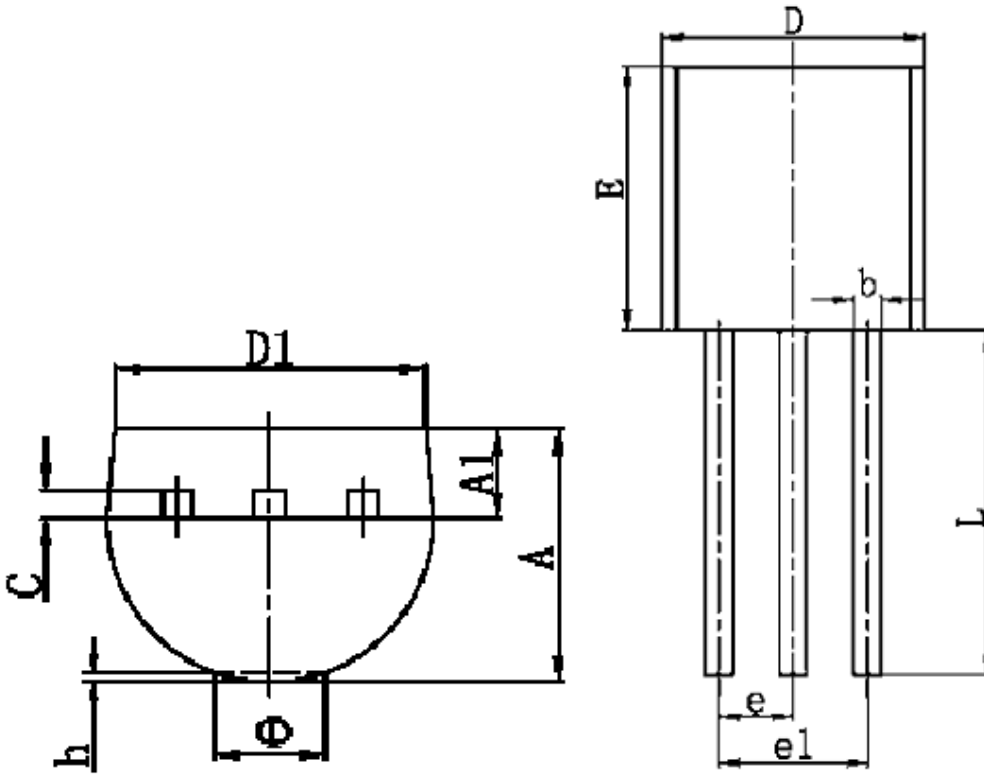

符号	最小值 (mm)	最大值 (mm)
A	3.300	3.700
A1	1.100	1.400
b	0.380	0.550
c	0.360	0.510
D	4.400	4.700
D1	3.430	
E	4.300	4.700
e	1.270 TYP	
e1	2.440	2.640
L	14.100	14.500
Φ		1.600
h	0.000	0.380

SOT-89-3

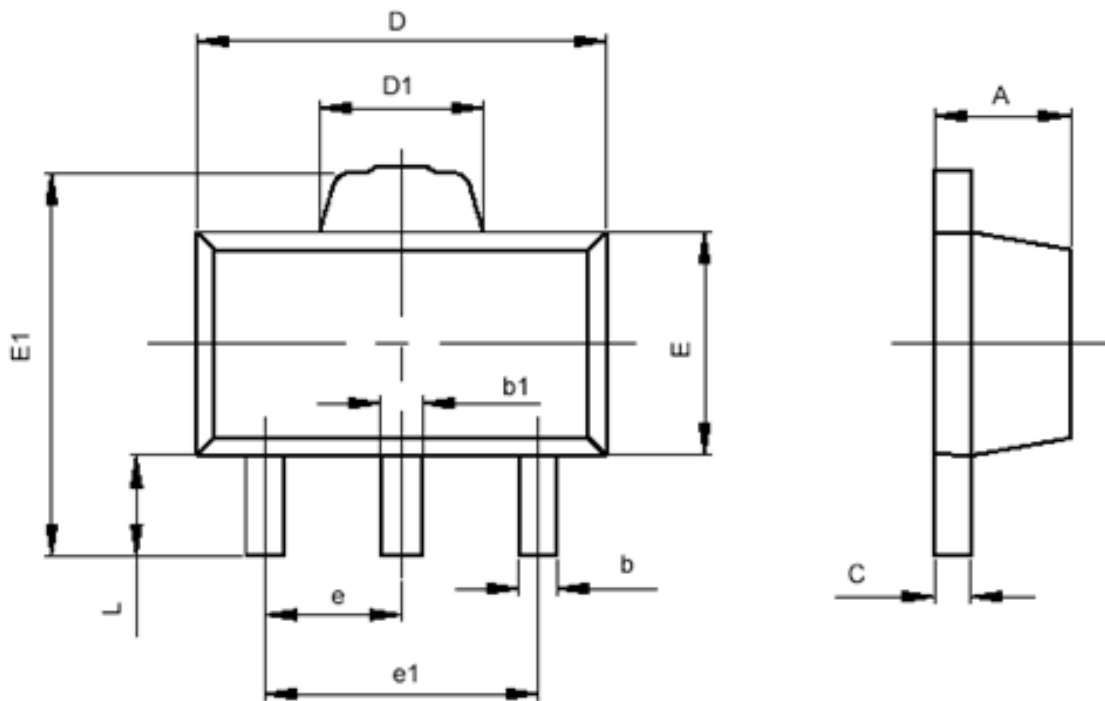

符号	最小值 (mm)	最大值 (mm)
A	1.400	1.600
b	0.320	0.520
b1	0.360	0.560
c	0.350	0.440
D	4.400	4.600
D1	1.400	1.800
E	2.300	2.600
E1	3.940	4.250
e	1.500TYP	
e1	2.900	3.100
L	0.900	1.100