

1.5MHz, 800mA Synchronous Step-Down Converter
FEATURES

- High Efficiency: Up to 96%
- 1.5MHz Constant Frequency Operation
- 800mA Output Current
- No Schottky Diode Required
- 2.0V to 6.0V Input Voltage Range
- Output Voltage as Low as 0.6V
- PFM Mode for High Efficiency in Light Load
- 100% Duty Cycle in Dropout
- Low Quiescent Current: 20 μ A
- Slope Compensated Current Mode Control for Excellent Line and Load Transient Response
- Short Circuit Protection
- Thermal Fault Protection
- Inrush Current Limit and Soft Start
- <1 μ A Shutdown Current
- Tiny SOT23-5 Package

APPLICATIONS

- Cellular and Smart Phones
- Wireless and DSL Modems
- PDAs
- Digital Still and Video Cameras
- MP3 Players

GENERAL DESCRIPTION

The HT8008A is a constant frequency, current mode step-down converter. The device integrates a main switch and a synchronous rectifier for high efficiency without an external Schottky diode. It is ideal for powering portable equipment that runs from

a single cell Lithium-Ion (Li+) battery. The output voltage can be regulated as low as 0.6V. The HT8008A can also run at 100% duty cycle for low dropout operation, extending battery life in portable system. This device offers two operation modes, PWM control and PFM Mode switching control, which allows a high efficiency over the wider range of the load.

The HT8008A is offered in a low profile (1mm) 5-pin, thin SOT package, and is available in an adjustable version.

Typical Application

Figure 1. Basic Application Circuit



Absolute Maximum Ratings (Note 1)

Input Supply Voltage -0.3V to 6.5V Operating Temperature Range ... -40°C to +85°C
 RUN,FB Voltages..... -0.3V to 6.5V Junction Temperature(Note2)125°C
 SW Voltage-0.3V to (Vin+0.3V) Storage Temperature Range-65°C to 150°C
 Peak SW Sink and Source Current...1.8A Lead Temperature(Soldering,10s)+300°C

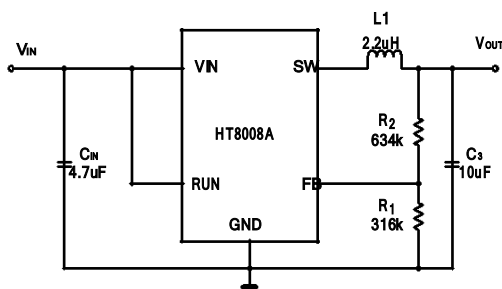
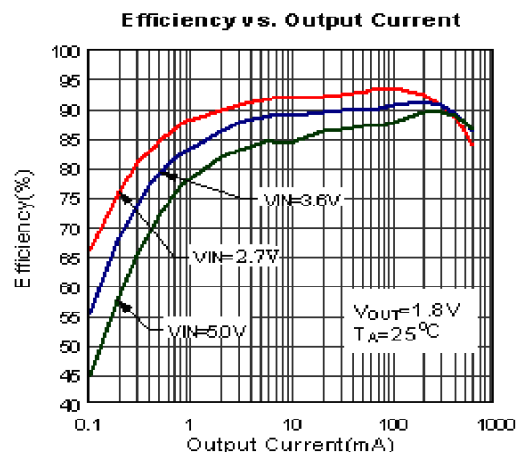
Package/Order Information

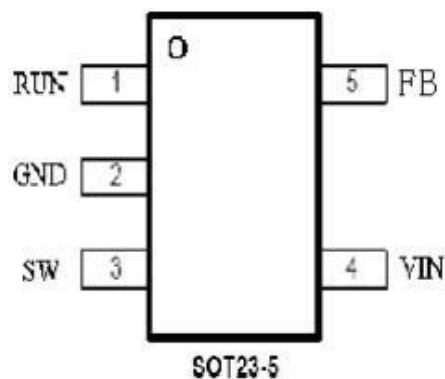

Part Number	SWICHING FREQUENCY	Temp Range	OUTPUT VOLTAGE (V)	OUTPUT CURRENT (A)
HT8008A	1.5MHz	-40°C to +85°C	ADJ	0.8

Pin Description

PIN	NAME	FUNCTION
1	RUN	Chip Enable Pin. Drive RUN above 1.5V to turn on the part. Drive RUN below 0.3V to turn it off. Do not leave RUN floating.
2	GND	Ground Pin
3	SW	Power Switch Output. It is the switch node connection to Inductor. This pin connects to the drains of the internal P-ch and N-ch MOSFET switches.
4	VIN	Power Supply Input. Must be closely decoupled to GND with a 4.7μF or greater ceramic capacitor.
5	FB	Feedback Pin. An internal resistive divider divides the output voltage down for comparison to the internal reference voltage.

Electrical Characteristics (Note 3)

($V_{IN}=V_{RUN}=3.6V$, $V_{OUT}=1.8V$, $T_A = 25^\circ C$, unless otherwise noted.)

Parameter	Conditions	MIN	TYP	MAX	unit
Input Voltage Range		2.0		6.0	V
UVLO Threshold		1.7	1.9	2.1	V
Input DC Supply Current	(Note 4)				μA
PWM Mode	$V_{out} = 90\%$, $I_{load}=0mA$		140	300	μA
PFM Mode	$V_{out} = 105\%$, $I_{load}=0mA$		20	35	μA
Shutdown Mode	$V_{RUN} = 0V$, $V_{IN}=4.2V$		0.1	1.0	μA
Regulated Feedback Voltage	$T_A = 25^\circ C$	0.588	0.600	0.612	V
	$T_A = 0^\circ C \leq T_A \leq 85^\circ C$	0.586	0.600	0.613	V
	$T_A = -40^\circ C \leq T_A \leq 85^\circ C$	0.585	0.600	0.615	V
Reference Voltage Line Regulation	$V_{in}=2.7V$ to $5.5V$		0.04	0.40	%/V
Output Voltage Line Regulation	$V_{IN} = 2.7V$ to $5.5V$		0.04	0.4	%
Output Voltage Load Regulation			0.5		%
Oscillation Frequency	$V_{out}=100\%$		1.5		MHz
	$V_{out}=0V$		300		KHz
On Resistance of PMOS	$I_{SW}=100mA$		0.35	0.45	Ω
ON Resistance of NMOS	$I_{SW}=-100mA$		0.3	0.45	Ω
Peak Current Limit	$V_{IN}= 3V$, $V_{out}=90\%$		1.5		A
RUN Threshold		0.30	1.0	1.50	V
RUN Leakage Current			± 0.01	± 1.0	μA
SW Leakage Current	$V_{RUN}=0V$, $V_{IN}=V_{sw}=5V$		± 0.01	± 1.0	μA

Note 1: Absolute Maximum Ratings are those values beyond which the life of a device may be impaired.

Note 2: T_J is calculated from the ambient temperature T_A and power dissipation P_D according to the following formula: $T_J = T_A + (P_D) \times (250^\circ C/W)$.

Note3: 100% production test at $+25^\circ C$. Specifications over the temperature range are guaranteed by design and characterization.

Note 4: Dynamic supply current is higher due to the gate charge being delivered at the switching frequency

Typical Performance Characteristics

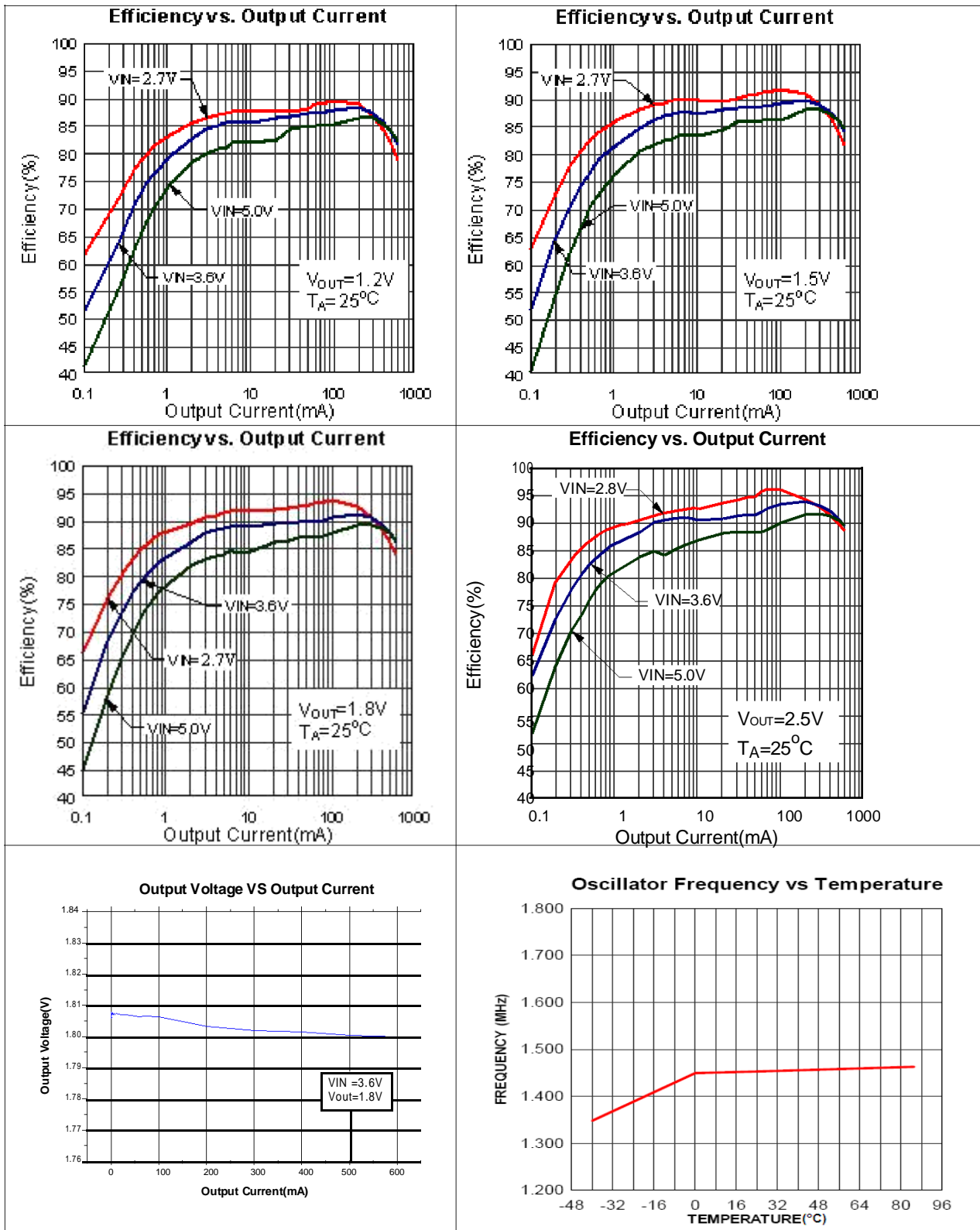

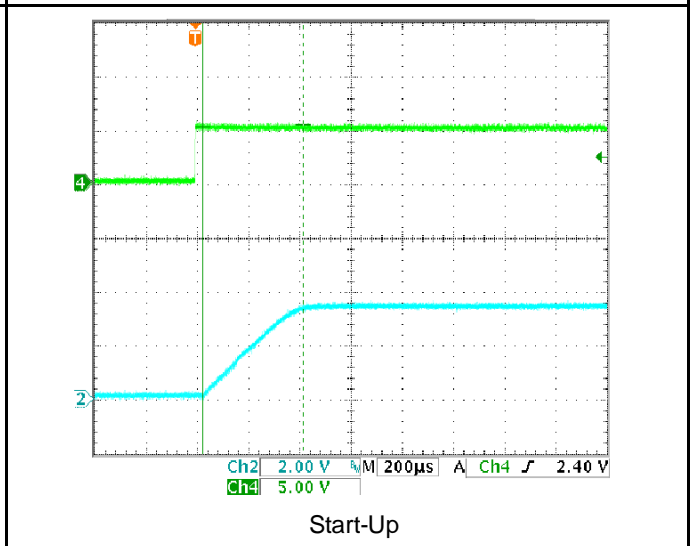
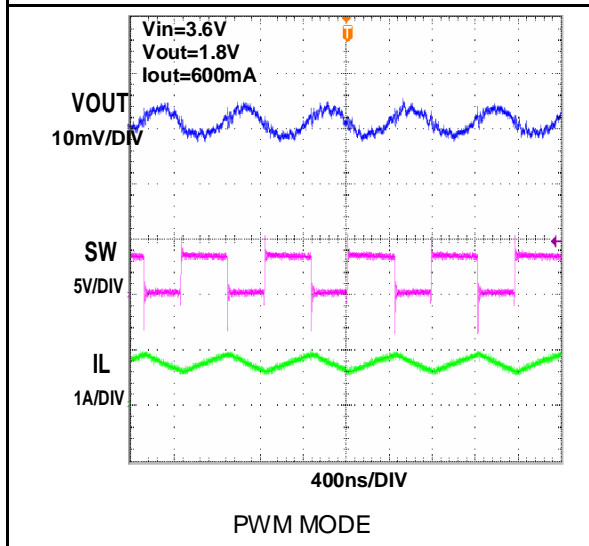
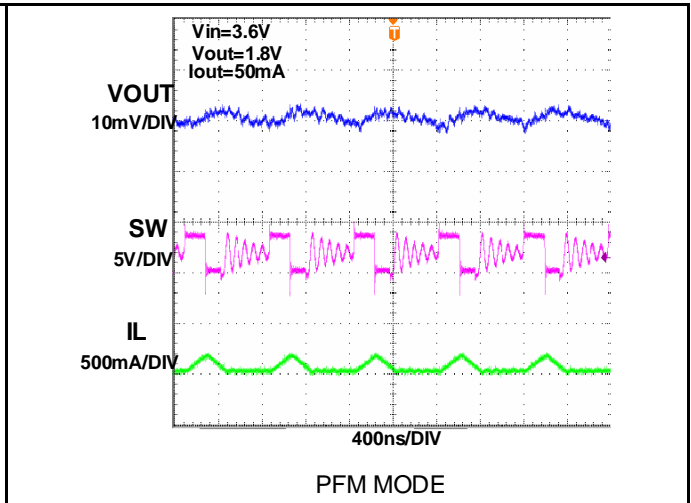
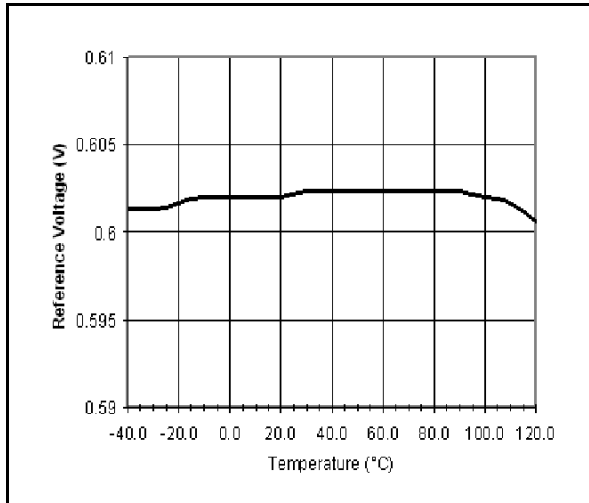

Functional Block Diagram

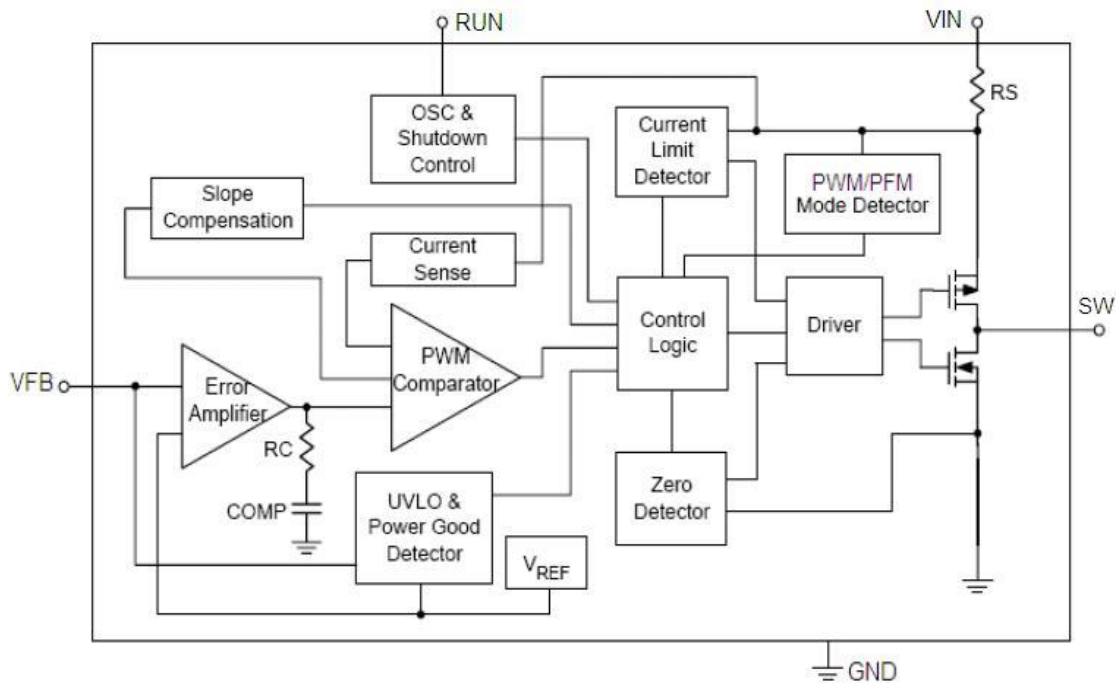

Figure 2. HT8008A Block Diagram

Functional Description

The HT8008A is a high performance, 600mA, 1.5MHz monolithic step-down converter. The HT8008A requires only three external power components (C_{in} , C_{out} and L). The adjustable version can be programmed with external feedback to any voltage, ranging from 0.6V to the input voltage.

At dropout operation, the converter duty cycle increases to 100% and the output voltage tracks the input voltage minus the R_{dson} drop of the high-side MOSFET. The internal error amplifier and compensation provides excellent transient response, load, and line regulation. Soft start function prevents input inrush current and output overshoot during start up.

APPLICATIONS INFORMATION

Setting the Output Voltage

The internal reference V_{REF} is 0.6V(Typical). The output voltage is divided by a resistor, R_1 and R_2 to the FB pin. The output voltage is given by:

$$V_{out} = V_{REF}(1 + R_2/R_1).$$

Inductor Selection

For most designs, the HT8008A operates with inductors of $1\mu\text{H}$ to $4.7\mu\text{H}$. Low inductance values are physically smaller but require faster switching, which results in some efficiency loss. The inductor value can be derived from the following equation:

$$L = \frac{V_{OUT} \times (V_{IN} - V_{OUT})}{V_{IN} \times \Delta I_L \times f_{OSC}}$$

Where ΔI_L is inductor Ripple Current.

Large value inductors result in lower ripple current and small value inductors result in high ripple current. For optimum voltage-positioning load transients, choose an inductor with DC series resistance in the $50\text{m}\Omega$ to $150\text{m}\Omega$ range.

Input Capacitor Selection

The input capacitor reduces the surge current drawn from the input and switching noise from the device. The input capacitor impedance at the switching frequency should be less than input source impedance to prevent high frequency switching current passing to the input. A low ESR input capacitor sized for maximum RMS current must be used. Ceramic capacitors with X5R or X7R dielectrics are highly recommended because of their low ESR and small temperature coefficients. A $4.7\mu\text{F}$ ceramic capacitor for most applications is

sufficient. A large value may be used for improved input voltage filtering.

Output Capacitor Selection

The output capacitor is required to keep the output voltage ripple small and to ensure regulation loop stability. The output capacitor must have low impedance at the switching frequency. Ceramic capacitors with X5R or X7R dielectrics are recommended due to their low ESR and high ripple current ratings. The output ripple

ΔV_{OUT} is determined by:

$$\Delta V_{OUT} \leq \frac{V_{OUT} \times (V_{IN} - V_{OUT})}{V_{IN} \times f_{OSC} \times L} \left(\frac{1}{8 \times f_{osc} \times C_3} + \frac{ESR}{8 \times f_{osc} \times C_3} \right)$$

A $10\mu\text{F}$ ceramic can satisfy most applications.

PCB Layout Recommendations

When laying out the printed circuit board, the following checking should be used to ensure proper operation of the HT8008A.

Check the following in your layout:

1. The power traces, consisting of the GND trace, the SW trace and the VIN trace should be kept short, direct and wide.
2. Does the (+) plates of C_{in} connect to V_{in} as closely as possible. This capacitor provides the AC current to the internal power MOSFETs.
3. Keep the switching node, SW, away from the sensitive V_{OUT} node.
4. Keep the (-) plates of C_{in} and C_{out} as close as possible

Package Description

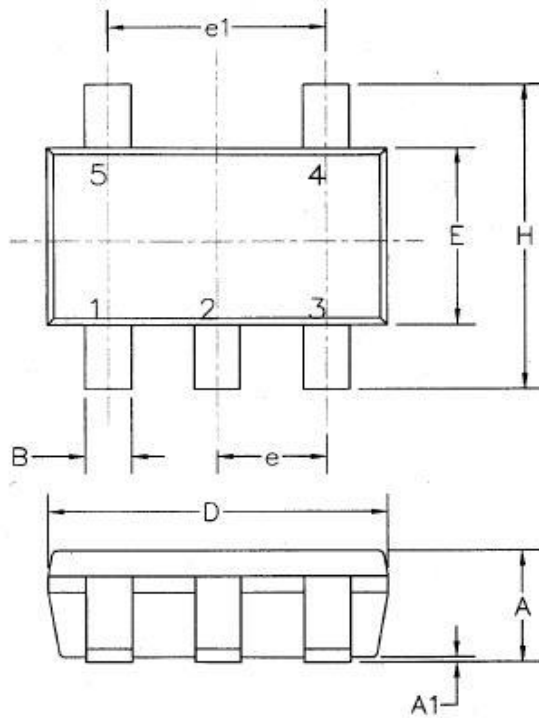

5LD SOT-23 PACKAGE OUTLINE DIMENSIONS
ALL DIMENSIONS IN MM.

Dimension	Min.	Max.
A	0.9	1.10
A1	0.01	0.13
B	0.3	0.5
C	0.09	0.2
D	2.8	3.0
H	2.5	3.1
E	1.5	1.7
e	0.95 REF.	
e1	1.90 REF.	
L1	0.2	0.55
L	0.35	0.8
Q	0°	10°

