

深圳市晶科鑫实业有限公司

样品承认书

客户代码:					
物料名称:	陶瓷谐振器				
规格型号:	ZTT 4.000MHZ 3PIN 0.30% -20~80℃ 蓝壳				
P N/ SJK:	ZTT04000				
环保属性:	<input checked="" type="checkbox"/> RoHS <input checked="" type="checkbox"/> REACH <input checked="" type="checkbox"/> HF <input type="checkbox"/> PAHS <input type="checkbox"/> 其它				
版 次:	A1 2017-7-1 初版			最小包装: 500只/包	
湿敏等级:	一级				

承 认 签 章					
供 应 商 承 认			() 公 司 承 认		
制 定	审 核	核 准	工 程 师	审 核	批 准
贺丹斌	李相同	刘惠光			
SJK 支持			盖章签署		
FAE_EMAIL			日 期		
日 期			批示: <input type="checkbox"/> 接受 <input type="checkbox"/> 有条件接受		
备注:					

CERAMIC RESONATOR



ZTT Series with Built-in Capacitor

1. SCOPE

This specification shall cover the characteristics of the ceramic resonator with the type ZTTWS4.00MG.

2. PART NO.

PART NUMBER	PREVIOUS PART NUMBER
ZTT4.000MG	ZTT4.000MG
CUSTOMER PART NO	SPECIFICATION NO

3. OUTLINE DIMENSIONS AND MARK

3.1 Appearance: No visible damage and dirt.

3.2 Construction: Leads are soldered on electrode and body is molded by resin.

3.3 The products conform to the RoHS directive and national environment protection law.

3.4 Dimensions and mark

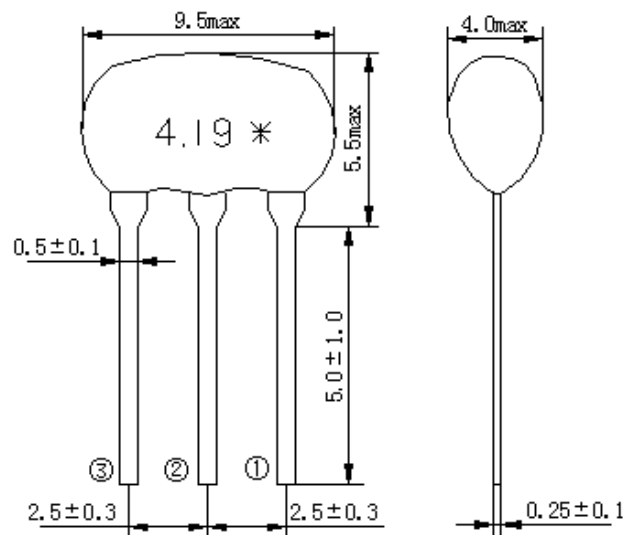

*:EIAJ MONTHLY CODE

CERAMIC RESONATOR



ZTT Series with Built-in Capacitor

4. ELECTRICAL SPECIFICATIONS

4.1 RATING

Items	Requirement
Withstanding Voltage (V)	50 (DC, 1min)
Insulation Resistance R_i , ($M\Omega$) min.	500 (10V, 1min)
Operating temperature	-20°C ~ 80°C
Storage temperature	-55°C ~ 85°C
Rating Voltage UR (V)	6V DC
	15V p-p

4.2 ELECTRICAL SPECIFICATIONS

Items	Requirement
Oscillation Frequency F_{osc} (MHz)	4.000
Frequency Accuracy (%)	± 0.3
Resonant Impedance R_o (Ω) max.	30
Temperature Coefficient of Oscillation Frequency (%) max.	± 0.3 (Oscillation Frequency drift, -20°C ~ +80°C)
Oscillation Frequency Aging Rate (%) max *	± 0.3 (From initial value)

* Components shall be left in a chamber of $+85 \pm 2^\circ\text{C}$ for 1000 hours, then measured after leaving in natural condition for 1 hour.

5. TEST

5.1 Test Conditions

Parts shall be tested under the condition (Temp.: $20 \pm 15^\circ\text{C}$, Humidity: $65 \pm 20\%$ R.H.) unless the standard condition (Temp.: $25 \pm 2^\circ\text{C}$, Humidity : $65 \pm 5\%$ R.H.) is regulated to measure.

5.2 Test Circuit

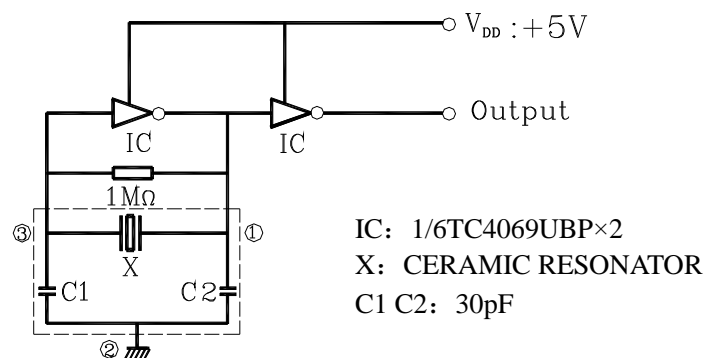

CERAMIC RESONATOR



ZTT Series with Built-in Capacitor

6 PHYSICAL AND ENVIRONMENTAL CHARACTERISTICS

No.	Item	Condition of Test	Performance Requirement	
6.1	Humidity	Subject the resonator at $40 \pm 2^\circ\text{C}$ and 90%-95% R.H. for 500h, resonator shall be measured after being placed in natural conditions for 1h.	It shall fulfill Table 1.	
6.2	High Temperature Exposure	Subject the resonator to $85 \pm 2^\circ\text{C}$ for 500h, resonator shall be measured after being placed in natural conditions for 1h.	It shall fulfill Table 1.	
6.3	Low Temperature Exposure	Subject the resonator to $-55 \pm 2^\circ\text{C}$ for 500h, resonator shall be measured after being placed in natural conditions for 1h.	It shall fulfill Table 1.	
6.4	Temperature Cycling	After temperature cycling of blow table was performed 5 times, resonator shall be measured after being placed in natural conditions for 1h.	It shall fulfill Table 1.	
		Temperature		Time
		$-25 \pm 3^\circ\text{C}$		30 ± 3 min
		$85 \pm 3^\circ\text{C}$	30 ± 3 min	
6.5	Vibration	Subject the resonator to vibration for 2h. Each in x y and z axis with the amplitude of 1.5mm, The frequency shall be varied uniformly between the limits of 10Hz-55Hz and then resonator shall be measured.	It shall fulfill Table 1.	
6.6	Mechanical Shock	Resonator shall be measured after 3 times random dropping from the height of 1m on concrete floor.	No visible damage and it shall fulfill Table 1.	
6.7	Resistance to Soldering Heat	Lead terminals are immersed up to 2 mm from resonator's body in soldering bath of $260^\circ\text{C} \pm 5^\circ\text{C}$ for $10\text{s} \pm 1\text{s}$ and then resonator shall be measured after being placed in natural conditions for 1h.	It shall fulfill Table 1.	
6.8	Solderability	Lead terminals are immersed up to 2mm from resonator's body in soldering bath of $250^\circ\text{C} \pm 5^\circ\text{C}$ for $3\text{s} \pm 0.5\text{s}$.	More than 95% of the terminal surface of the filter shall be covered with fresh solder.	

CERAMIC RESONATOR



ZTT Series with Built-in Capacitor

6. ENVIRONMENTAL TEST

No.	Item	Condition of Test	Performance Requirements
6.9	Terminal Strength		
6.9.1	Terminal Pulling	Force of 5N is applied to each lead in axial direction for 10s ± 1s.	No visible damage and it shall fulfill Table 1.
6.9.2	Terminal Bending	When force of 5N is applied to each lead in axial direction, the lead shall be folded up 90 ° from the axial direction and folded back to the axial direction. The speed of folding shall be each 3s.	

Table 1

Item	Specification after test
Oscillation Frequency Change $\Delta f_{osc}/f_{osc}$ (%) max.	±0.3
Resonant Impedance R_o (Ω) max.	30

The limits in the above table are referenced to the initial measurements.

7. EIAJ Monthly Code

2005 / 2007 / 2009		2006 / 2008 / 2010	
MONTH	CODE	MONTH	CODE
JAN	A	JAN	N
FEB	B	FEB	P
MAR	C	MAR	Q
APR	D	APR	R
MAY	E	MAY	S
JUN	F	JUN	T
JUL	G	JUL	U
AUG	H	AUG	V
SEP	J	SEP	W
OCT	K	OCT	X
NOV	L	NOV	Y
DEC	M	DEC	Z

CERAMIC RESONATOR



ZTT Series with Built-in Capacitor

8. PACKAGE

To protect the products in storage and transportation, it is necessary to pack them (outer and inner package). On paper pack, the following requirements are requested.

8.1 Dimensions and Mark

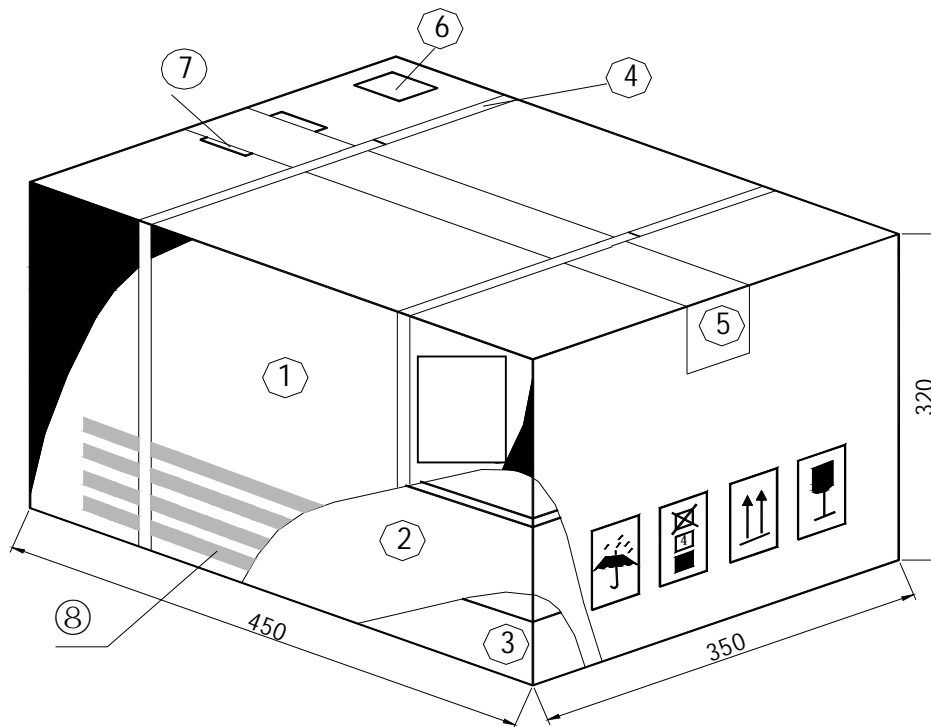

NO.	Name	Quantity
①	Package	1
②	Box	2
③	Inner Box	40
④	Belt	2.9 m
⑤	Adhesive tape	1.2 m
⑥	Label	1
⑦	Certificate of approval	1
⑧	Company name ,Address etc.	

8.2 Section of Package

Package is made of corrugated paper with thickness of 0.8cm. Package has 2 boxes, each has 20 inner boxes.

CERAMIC RESONATOR



ZTT Series with Built-in Capacitor

8.3 Quantity of Package

- Per plastic bag 500 pieces
- Per inner box @1 5 plastic bag
- Per package 40 inner boxes
- (@2 100000 pieces of piezoelectric ceramic part)

8.4 Inner Package

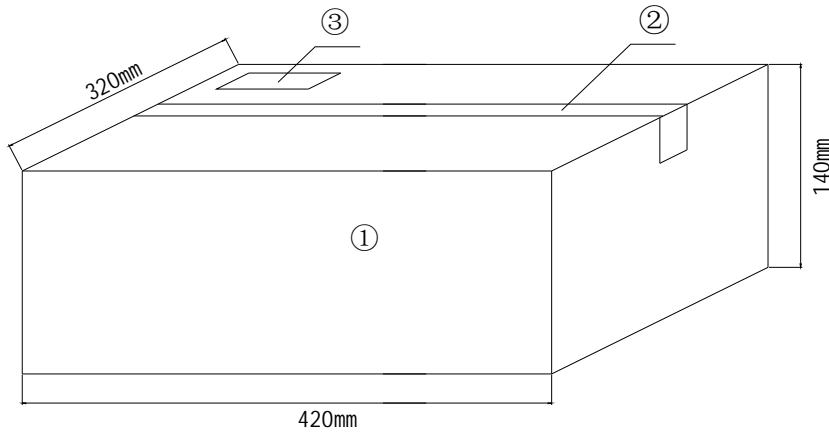

NO.	Name	Quantity
①	Inner package	1
②	Adhesive tape	1.2 m
③	Label	1

8.5 Inner Box Dimensions

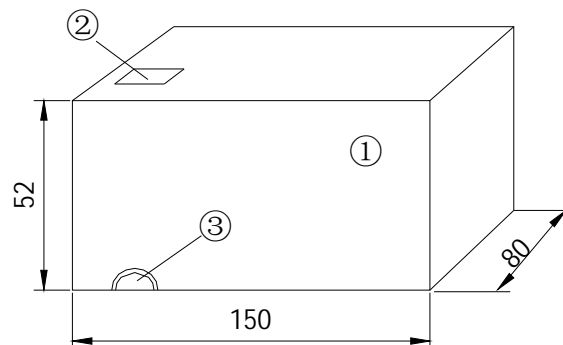

NO.	Name	Quantity
①	Inner Box	1
②	Label	1
③	QC Label	1

CERAMIC RESONATOR



ZTT Series with Built-in Capacitor

9. Wave soldering temperature curve

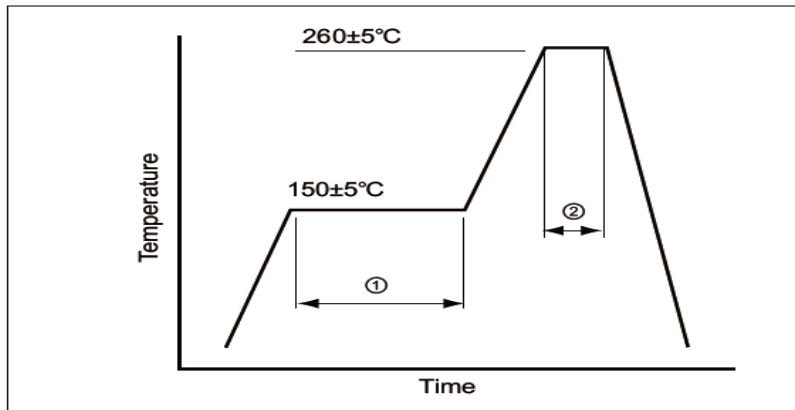

①	Preheat	150±5°C	120sec.
②	Peak	260°C	10sec. max.

Total time 200sec. max. Solder melting point: 185°C

10. OTHER

10.1 Caution

10.1.1 Don't apply excess mechanical stress to the component and terminals at soldering. Do not use this product with bend.

10.1.2 Do not clean or wash the component for it is not hermetically sealed.

10.1.3 Do not use strong acidity flux, more than 0.2wt% chlorine content, in flow soldering.

10.1.4 Don't be close to fire.

10.1.5 All kinds of re-flow soldering must not be applied on the component.

10.1.6 This specification mentions the quality of the component as a single unit. Please insure the component is thoroughly evaluated in your application circuit

10.1.7 Expire date (Shelf life) of the products is 12 months after delivery under the conditions of a sealed and an unopened package. Please use the products within six months after delivery. If you store the products for a long time (more than six months), use carefully because the products may be degraded in the solderability or rusty. Please confirm solderability and characteristics for the products regularly.

10.1.8 Please contact us before using the product as automobile electronic component.

10.2 Notice

10.2.1 Please return one of this specification after your signature of acceptance.

10.2.2 When something gets doubtful with this specification, we shall jointly work to get an agreement.