

**Boundary Conduction Mode**

# Power Factor Correction Controller IC

**BD7692FJ**

**General Description**

BD7692FJ is Power Factor Correction for AC/DC supplies the system which is suitable for all the products needing power factor improvement. The PFC adopts boundary conduction mode (BCM), and switching loss reduction and noise reduction are possible by Zero Current Detection (ZCD). ZCD detects by resistance, the auxiliary winding is unnecessary.

**Key Specifications**

- Input Voltage Range: 10 V to 26 V
- Operating Current: 470  $\mu$ A (Typ)
- Maximum Frequency: 450 kHz ( $R_{RT}120\text{ k}\Omega$ )
- Operating Temperature Range: -40 °C to +105 °C

**Package**  
SOP-J8

**W(Typ) x D(Typ) x H(Max)**  
4.90 mm x 6.00 mm x 1.65 mm

**Features**

- Boundary Conduction Mode
- Low Power Consumption
- VCCUVLO
- Resister Detection for ZCD
- Switching Loss Reduction, Noise Reduction by ZCD
- Dynamic and Static OVP by the VS Pin
- High Accuracy Over Current Detection ( $\pm 4\%$ )
- Error Amplifier Input Short Protection
- Stable MOSFET Gate Drive by the Clamper
- Protection Function by the OVP Pin
- Over Voltage Reduce by Soft Start
- Safe Design by the IS-GND Short Timer Operation

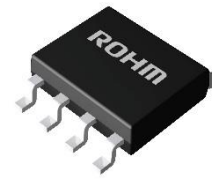

**Applications**

- AC Adofter, TV, Lighting Equipment, Refrigerator, etc.

**Typical Application Circuit**

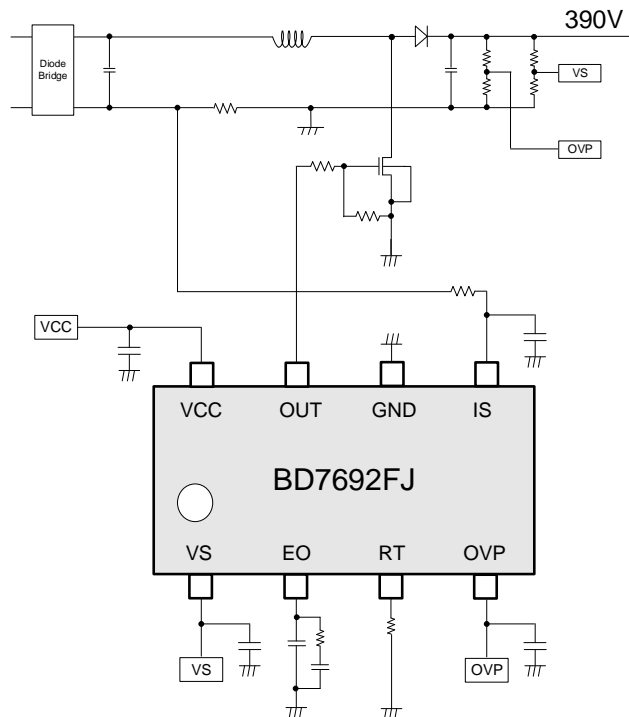

○Product structure : Silicon integrated circuit ○This product has no designed protection against radioactive rays

Pin Configuration

(TOP VIEW)

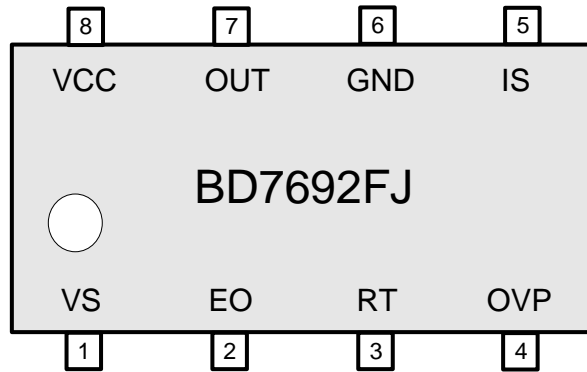

Pin Descriptions

Pin No.	Pin Name	I/O	Function	ESD Diode	
				VCC	GND
1	VS	I	Feedback input	-	○
2	EO	I/O	Error amp output	-	○
3	RT	I/O	Maximum frequency setting	-	○
4	OVP	I	Over voltage protection	-	○
5	IS	I	Zero current and over current detection	-	○
6	GND	-	GND	○	-
7	OUT	O	External MOSFET gate control	-	○
8	VCC	I	VCC	-	○

Block Diagram

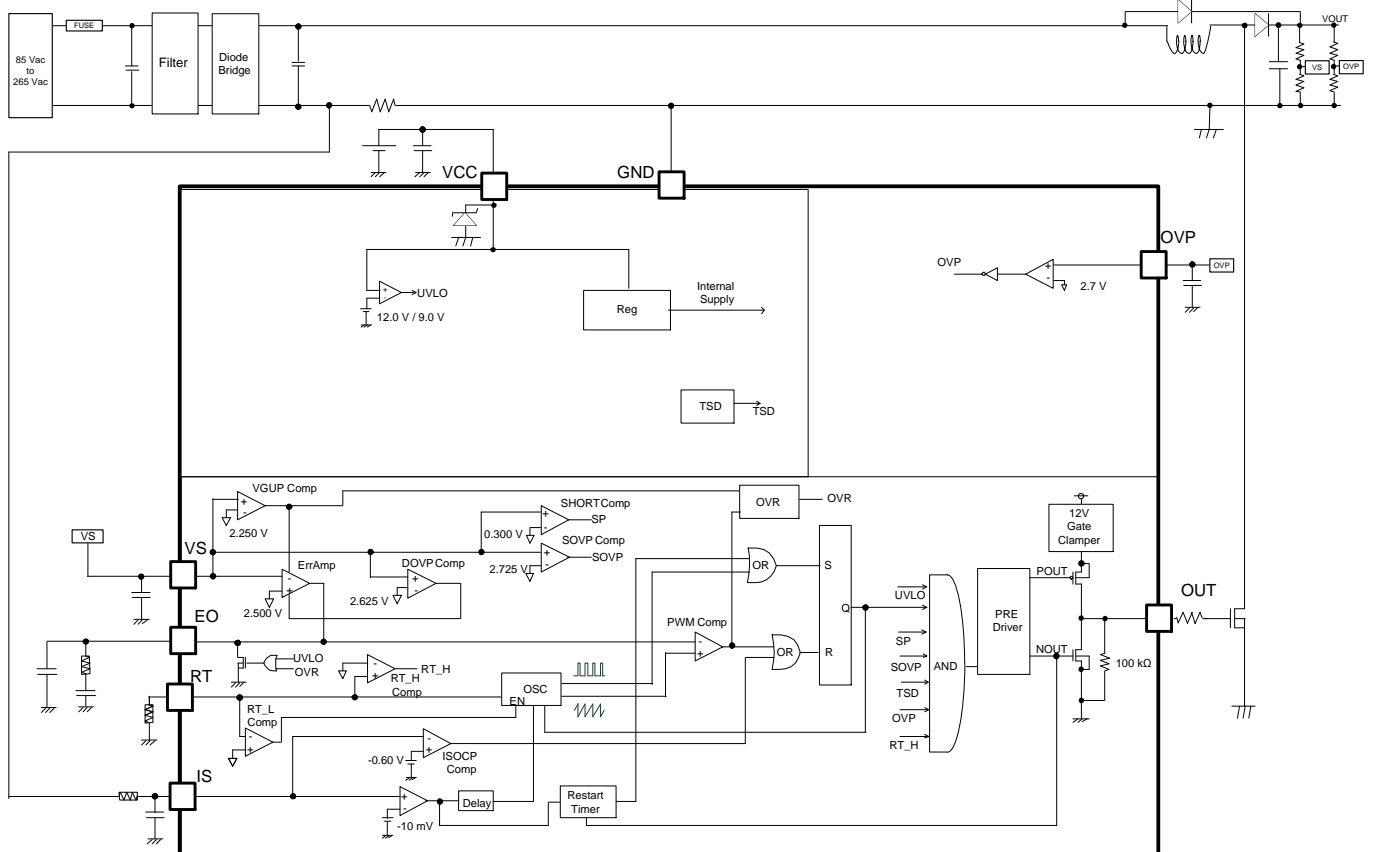

**Description of Blocks**

**1 VCC Protection**

This IC has VCC UVLO (Under Voltage Lock Out) of the VCC pin. Switching stops at the time of VCC voltage drop.

**2 Power Factor Correction**

The power factor improvement circuit is a voltage control method of Boundary Conduction Mode. The outline operation circuit diagram is shown in Figure 1. The switching operation is shown in Figure 2.

**Switching Operation**

1. MOSFET is turned on, and  $I_L$  increases.
2. The IC compares  $V_{EO}$  with  $V_{RAMP}$  slope decided in RT pin, and MOSFET is off when the  $V_{RAMP}$  voltage higher than  $V_{EO}$ .
3. MOSFET is off, and  $I_L$  decreases.
4. The IS pin detects a zero point of the  $I_L$  and turns on MOSFET.

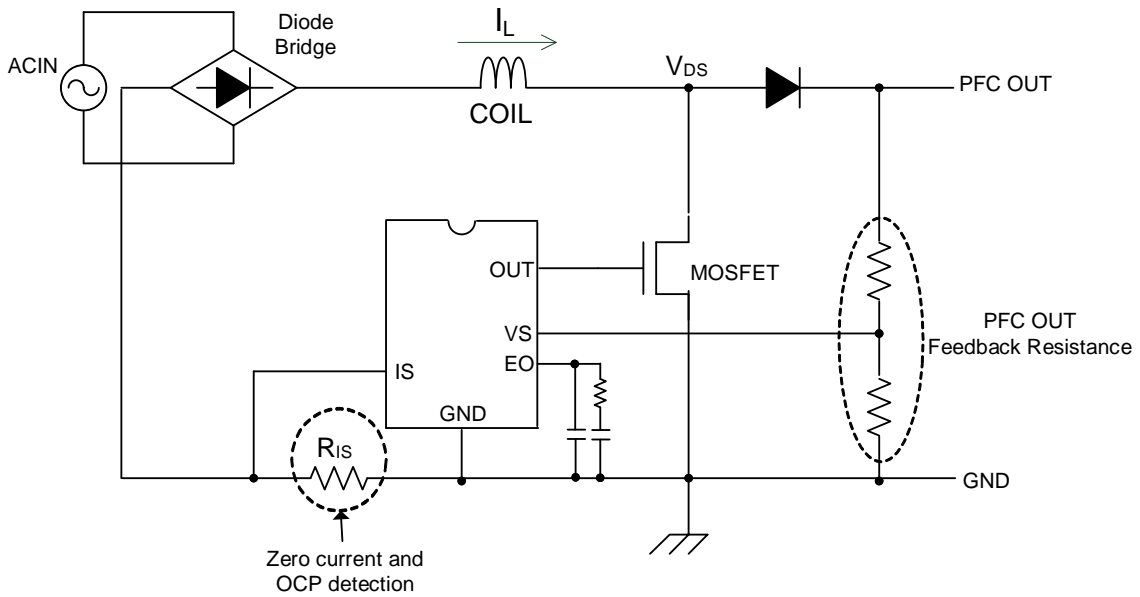

Figure 1. Operation Circuit Outline

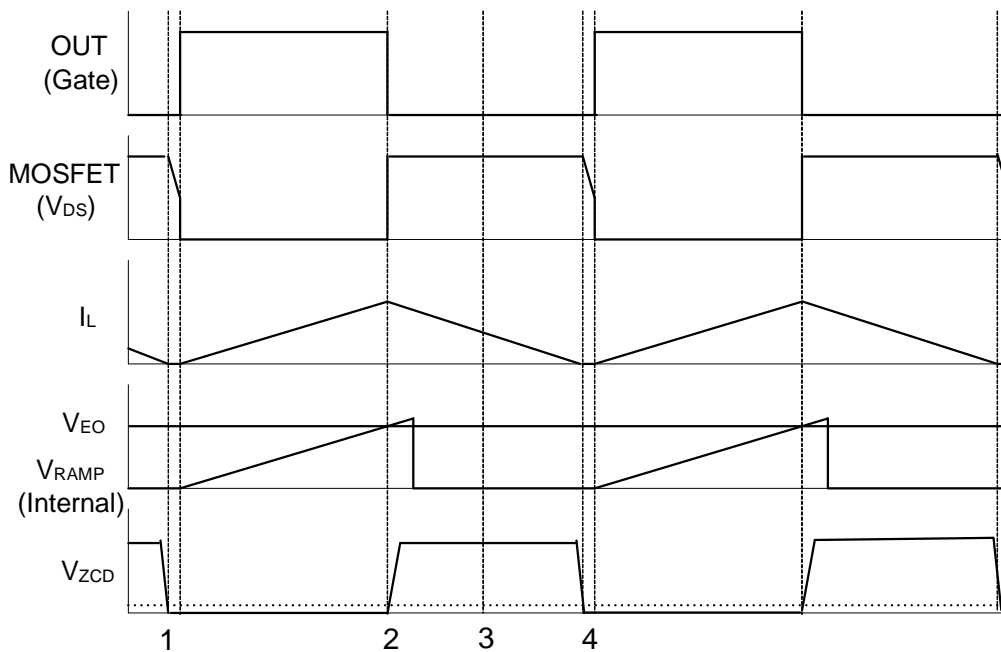

Figure 2. Switching Operation Timing Chart

## Description of Blocks - continued

## 3 About ErrAMP

## 3.1 GmAMP

The VS pin monitors a divided point for resistance of the output voltage. The ripple voltage of AC frequency (50 Hz/60 Hz) overlaps with the VS pin. GmAMP removes this ripple voltage. GmAMP compares  $V_{AMP}$  (2.500 V Typ) with the removed voltage, GmAMP controls the EO voltage by this gap. When the EO pin voltage rises, ON width of the OUT pin becomes wide. When the EO voltage less than  $V_{OFF\_TH}$  (0.30 V Typ), the IC stops switching. Therefore, it can stop switching operation when the EO pin connects to the GND. Please set the external parts number of the error amplifier so that AC frequency does not overlap in EO pin. And, please confirm it by an actual board.

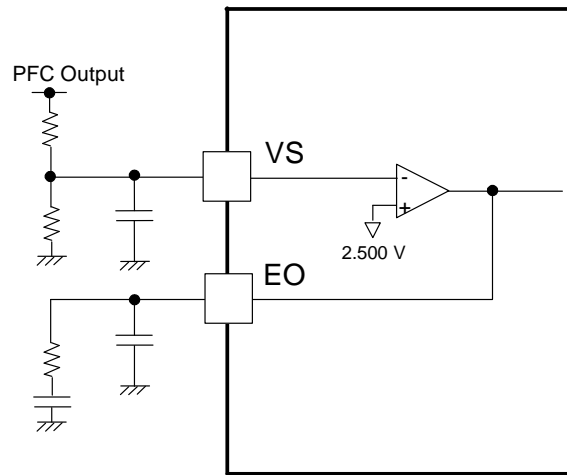

Figure 3. GmAMP Block Diagram

## 3.2 VS Short Protection

The VS pin has a short protection function.

A state of VS pin voltage  $< V_{SHORT}$  (0.300 V Typ) continues  $t_{VS\_SH}$  (150  $\mu$ s Typ) or more, it stops switching. Figure 4 shows the operation.

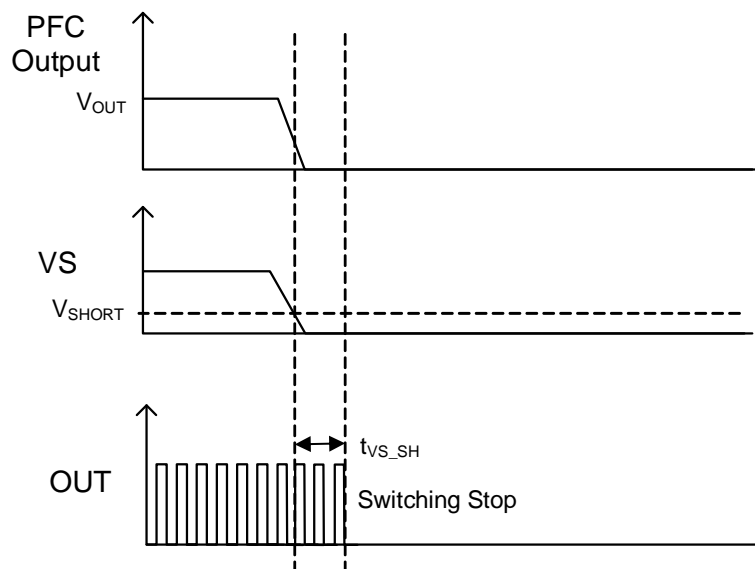

Figure 4. Operation of VS Short Protection

## 3.3 VS Low Voltage Gain Increase Function

When output voltage decreases by output load sudden changes, an output voltage drop period becomes long because a voltage control loop is slow. The VS pin voltage becomes lower than  $V_{GUP}$  (2.250 V Typ) (equivalent to -10 % of output voltage), the error amplifier increases the speed of the voltage control loop. ON width of OUT increases and prevents a long-term drop of the output voltage. When the VS pin voltage rises from  $V_{GUP}$  (2.250 V Typ), this operation stops.

3 About ErrAMP - continued

3.4 VS Overvoltage Gain Increase Function (DOVP)

When output voltage rises by startup or a rapid change of the output load, output voltage rises for a long term because a voltage control loop is slow. The VS pin voltage becomes  $V_{OVP}$  (2.625 V Typ) (equivalent to +5 % of output voltage), the error amplifier increases the speed of the voltage control loop. By this operation, it reduces ON width of OUT and prevents a long-term rise of the output voltage. When the VS pin voltage decreases under  $V_{OVP}$  (2.625 V Typ), this operation stops.

3.5 VS Overvoltage Protection Function (SOVP)

IC has static OVP for the time when VS is above the overvoltage gain increase function voltage  $V_{OVP}$ . The VS pin voltage rises from  $V_{OVP1}$  (2.725 V Typ), it stops switching immediately. The VS pin voltage less than  $V_{OVP2}$  (2.600 V Typ), it starts switching. Figure 5 shows the operation.

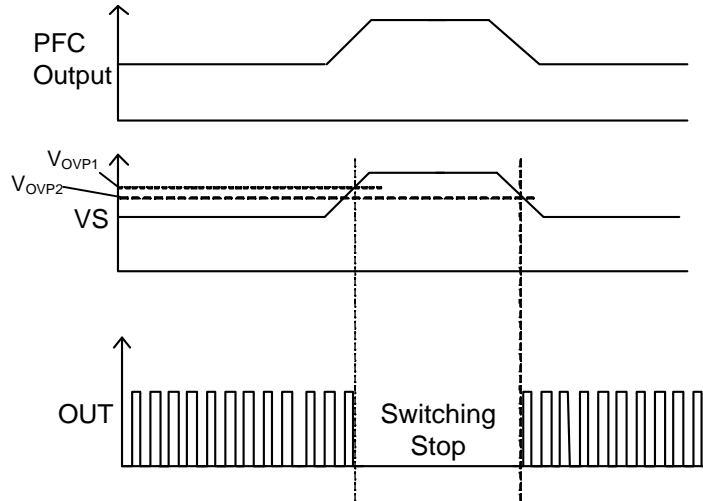

Figure 5. VS Overvoltage Protection Operation

3.6 Over Voltage Reduce Function at Start Up (OVR)

When the VS pin voltage performs a rise in startup to  $V_{GUP}$  (2.250 V Typ) (equivalent to -10 % of output voltage), it discharges the EO voltage to the off threshold voltage forcibly. OUT pulse width is narrows when the EO voltage falls, through rate of output voltage becomes slow and reduces over voltage in the startup. This function is effective only once after VCCUVLO cancellation.

4 OVP Pin Over Voltage Protection

The OVP pin is an overvoltage protection function to use when VS feedback circuit is above static OVP (cf. Figure 6) at the time of abnormality. When the OVP pin voltage rises over  $V_{OVP3}$  (2.7 V Typ), it stops switching operation after  $t_{OVP3}$  (60  $\mu$ s Typ) (cf. Figure 7). If the OVP pin becomes  $V_{OVP4}$  (2.6 V Typ) or less, it restarts operation.

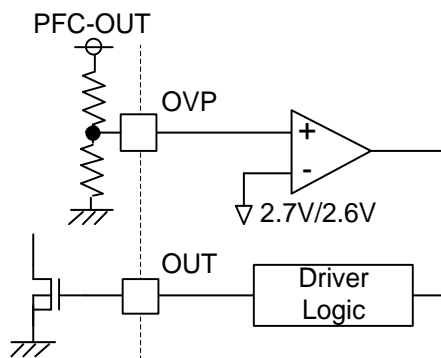

Figure 6. OVP Over Voltage Protection

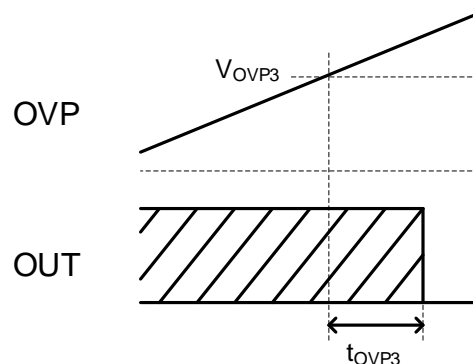

Figure 7. Timing Chart

## Description of Blocks - continued

## 5 IS Pin

## 5.1 Zero Current Detection and Overcurrent Detection Function

The zero current detection circuit is a function to detect a zero cross of the inductor current ( $I_L$ ) (cf. Figure 8).

When the voltage of the IS pin becomes higher than the zero current detection voltage, the OUT output becomes High after progress at zero current detection delay time ( $t_{ZCDD}$  1.35  $\mu$ s Typ). Please set the  $R_{IS}$  value about the overcurrent detection of the inductor current ( $I_L$ ) so that the IS pin voltage becomes  $V_{IS\_OCP}$  (-0.60 V Typ) or less. In addition, it recommends that to add CR filter for switching noise reduction. Figure 9 shows the operation.

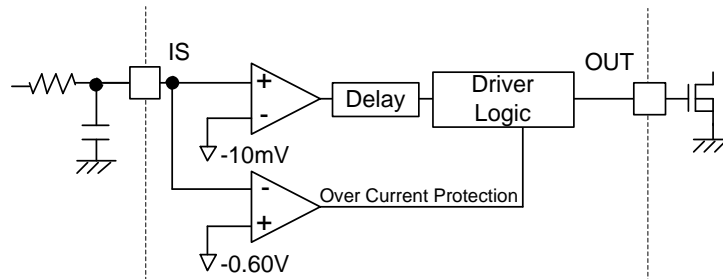

Figure 8. IS Current Detection Circuit

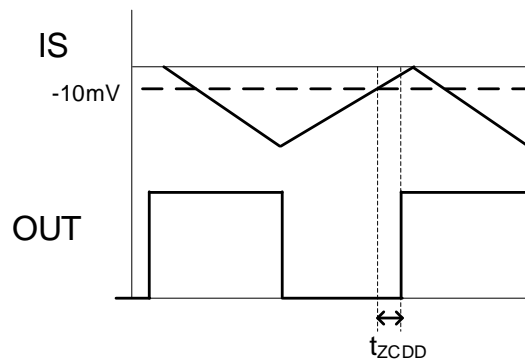

Figure 9. IS Zero Current Detection Delay Time

## 5.2 IS-GND Short Function

When the IS pin short-circuits with the GND pin, zero current detection is not possible. It is the IS voltage  $>$  -10 mV in off timing of the OUT pin in the case of -10 mV, IC operates the restart timer. It can prevent CCM operation by discharging the current which collected to the coil in a restart time.

## 6 RT Pin

This pin sets frequency of the slope voltage formed in the IC inside by external resistance. Figure 10 shows RT resistor value and relations of the maximum frequency. The maximum ON width on the application is calculated in the following formula. Figure 11 shows relations of RT resistor value and maximum ON width.

$$t_{ON\_MAX} = \frac{2 \times L \times P_{O\_PFC}}{V_{INMIN}^2 \times \eta_{PFC}} \quad [s]$$

Where:

$V_{INMIN}$  is the minimum input voltage.

$L$  is the inductance.

$P_{O\_PFC}$  is the maximum output power.

$\eta_{PFC}$  is the efficiency.

Necessary  $t_{ON\_MAX}$  on application can be check as upper formula. Please set ON width in the RT pin  $t_{ON\_MAX}$  or more.

In addition, it shows relations of RT resistor value and PFC zero current detection Delay in Figure 12.

The high-speed frequency in the light load is limited by RT pin to improve efficiency in the light load.

External resistance of the RT pin can set only 39 k $\Omega$ , 68 k $\Omega$ , 120 k $\Omega$ , 220 k $\Omega$ , 470 k $\Omega$ .

Do not set the fixed number except the designated value for RT external resistance.

The IC reads RT resistor value at the time of VCCUVLO cancellation and establishes setting. The setting is not changed even if it changes RT resistor value after VCCUVLO cancellation.

6 RT Pin - continued

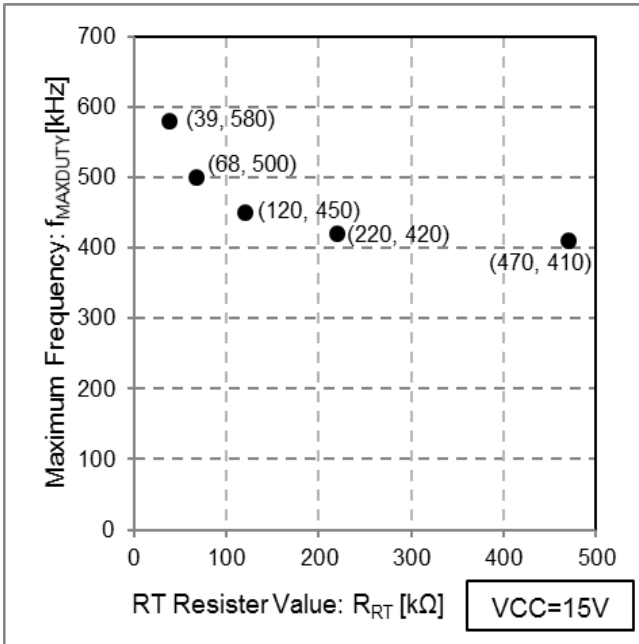

Figure 10. Maximum Frequency vs RT Resistor Value

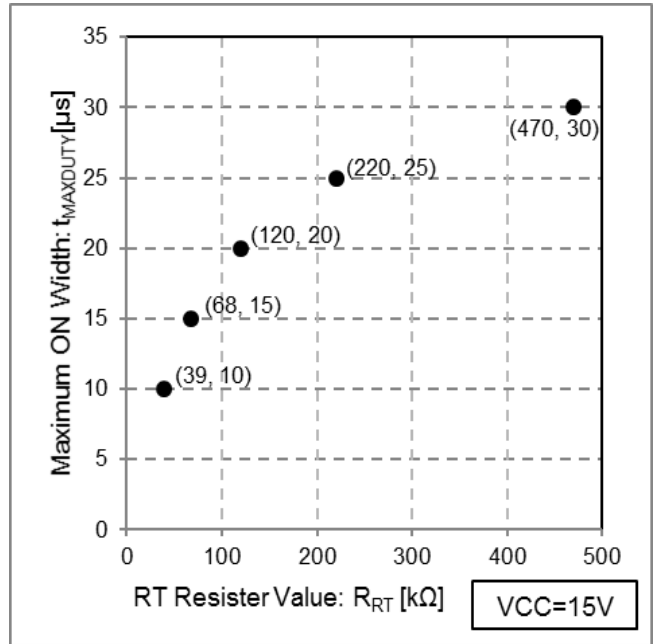

Figure 11. Maximum ON Width vs RT Resistor Value

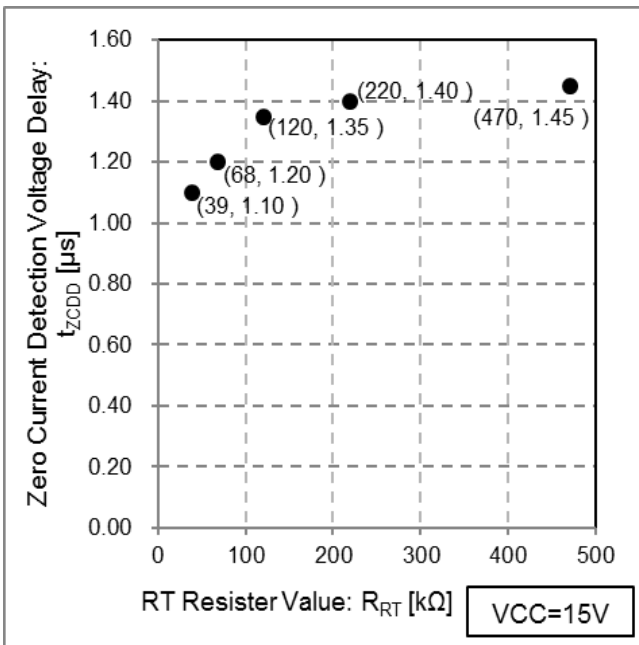

Figure 12. Zero Current Detection Voltage Delay vs RT Resistor Value

Table 1. RT Resistor Value Characteristics (reference value)

$R_{RT}$ (kΩ)	$f_{MAXDUTY}$ (kHz)	$t_{MAXDUTY}$ (μs)	$t_{ZCDD}$ (μs)
39	580	10	1.10
68	500	15	1.20
120	450	20	1.35
220	420	25	1.40
470	410	30	1.45

\*These table and graph mentioned above are reference value. After the confirmation of the actual board, please set the fixed number.

\*The characteristic kind to fluctuate by RT resistance is only five kinds. When RT resistance is set other than the resistor value mentioned above, it becomes the factor of the unstable operation.

### Operation Mode of the Protective Circuit

Table2 shows the operation mode of each protection function.

Table 2. Operation Mode of Each Protective Circuit

Parameter	Contents	Protection mode			
		Detection Method	Detect Operation	Cancellation Method	Cancellation Operation
VCCUVLO	VCC Pin Low Voltage Protection	$VCC < 9.0 \text{ V(Typ)}$ (VCC Drop)	OUT Stop EO Discharge	$VCC > 12.0 \text{ V(Typ)}$ (VCC Rise)	Startup Operation
IS OCP	IS Pin Over Current Protection	$IS < -0.60 \text{ V(Typ)}$ (IS Drop)	OUT Stop	$IS > -0.60 \text{ V(Typ)}$ (IS Rise)	Normal Operation
VS Short Protection	VS Pin Short Protection	$VS < 0.300 \text{ V(Typ)}$ (VS Drop)	OUT Stop EO Discharge	$VS > 0.300 \text{ V(Typ)}$ (VS Rise)	Normal Operation
VS Gain Increase	VS Pin Low Voltage Gain Increase	$VS < 2.250 \text{ V(Typ)}$ (VS Drop)	Gm Amplifier GAIN Increase	$VS > 2.250 \text{ V(Typ)}$ (VS Rise)	Normal Operation
VS Dynamic OVP	VS Pin Overvoltage Protection 1	$VS > 2.625 \text{ V(Typ)}$ (VS Rise)	Gm Amplifier GAIN Increase	$VS < 2.625 \text{ V(Typ)}$ (VS Drop)	Normal Operation
VS Static OVP	VS Pin Overvoltage Protection 2	$VS > 2.725 \text{ V(Typ)}$ (VS Rise)	OUT Stop	$VS < 2.600 \text{ V(Typ)}$ (VS Drop)	Normal Operation
OVP	OVP Pin Overvoltage Protection 3	$OVP > 2.700 \text{ V(Typ)}$ (OVP Rise)	OUT Stop	$OVP < 2.600 \text{ V(Typ)}$ (OVP Drop)	Normal Operation



**Absolute Maximum Ratings (Ta = 25 °C)**

Parameter	Symbol	Rating	Unit	Condition
Maximum Voltage 1	V <sub>MAX1</sub>	-0.3 to +28.0	V	VCC
Maximum Voltage 2	V <sub>MAX2</sub>	-0.3 to +15.0	V	OUT
Maximum Voltage 3	V <sub>MAX3</sub>	-0.3 to +6.5	V	OVP, RT, VS, EO
Maximum Voltage 4	V <sub>MAX4</sub>	-6.5 to +0.3	V	IS(Exclude 20 ms after input voltage injection)
IS Pin Maximum Current	I <sub>IS</sub>	-20	mA	IS(20 ms or less after input voltage injection)
OUT Pin Output Peak Current 1	I <sub>OUT1</sub>	-0.5	A	Source current
OUT Pin Output Peak Current 2	I <sub>OUT2</sub>	+1.0	A	Sink current
Maximum Junction Temperature	T <sub>jmax</sub>	+150	°C	
Storage Temperature Range	T <sub>stg</sub>	-55 to +150	°C	

**Caution 1:** Operating the IC over the absolute maximum ratings may damage the IC. The damage can either be a short circuit between pins or an open circuit between pins and the internal circuitry. Therefore, it is important to consider circuit protection measures, such as adding a fuse, in case the IC is operated over the absolute maximum ratings.

**Caution 2:** Should by any chance the maximum junction temperature rating be exceeded the rise in temperature of the chip may result in deterioration of the properties of the chip. In case of exceeding this absolute maximum rating, design a PCB with thermal resistance taken into consideration by increasing board size and copper area so as not to exceed the maximum junction temperature rating.

**Thermal Resistance**(Note 1)

Parameter	Symbol	Thermal Resistance (Typ)		Unit
		1s <sup>(Note 3)</sup>	2s2p <sup>(Note 4)</sup>	
SOP-J8				
Junction to Ambient	$\theta_{JA}$	149.3	76.9	°C/W
Junction to Top Characterization Parameter <sup>(Note 2)</sup>	$\Psi_{JT}$	18	11	°C/W

(Note 1) Based on JESD51-2A(Still-Air)

(Note 2) The thermal characterization parameter to report the difference between junction temperature and the temperature at the top center of the outside surface of the component package.

(Note 3) Using a PCB board based on JESD51-3.

(Note 4) Using a PCB board based on JESD51-7.

Layer Number of Measurement Board	Material	Board Size
Single	FR-4	114.3 mm x 76.2 mm x 1.57 mmt
Top		
Copper Pattern	Thickness	
Footprints and Traces	70 $\mu$ m	

Layer Number of Measurement Board	Material	Board Size			
4 Layers	FR-4	114.3 mm x 76.2 mm x 1.6 mmt			
Top		2 Internal Layers		Bottom	
Copper Pattern	Thickness	Copper Pattern	Thickness	Copper Pattern	Thickness
Footprints and Traces	70 $\mu$ m	74.2 mm x 74.2 mm	35 $\mu$ m	74.2 mm x 74.2 mm	70 $\mu$ m

**Recommended Operating Conditions**

Parameter	Symbol	Rating			Unit	Condition
		Min	Typ	Max		
Supply Voltage	VCC	10.0	15.0	26.0	V	VCC Voltage
Operation Temperature	Topr	-40	+25	+105	°C	

**Recommended Range of the External Component (Ta=25 °C)**

Parameter	Symbol	Rating	Unit
VCC Pin Connection Capacity	C <sub>VCC</sub>	10.0 or more	$\mu$ F
RT Resistor Value	R <sub>RT</sub>	39, 68, 120, 220, 470	k $\Omega$

Do not set the fixed number except the designated value for RT external resistance.

## Electrical Characteristics (Unless otherwise specified Ta = 25 °C, VCC = 15 V)

Parameter	Symbol	Specifications			Unit	Condition
		Min	Typ	Max		
<b>[Circuit Current]</b>						
Circuit Current(ON)1	I <sub>ON1</sub>	-	470	1000	μA	VS=1.0 V, EO=OPEN, R <sub>RT</sub> =120 kΩ, OVP=OPEN
Circuit Current (ON)2	I <sub>ON2</sub>	-	530	1200	μA	VS=1.0 V, EO=OPEN, R <sub>RT</sub> =120 kΩ, OVP=0 V (PULSE operation)
Start Up Current	I <sub>ON3</sub>	-	55	110	μA	VCC=11 V
<b>[VCC Pin Protection]</b>						
VCC UVLO Voltage1	V <sub>UVLO1</sub>	11.0	12.0	13.0	V	VCC rise
VCC UVLO Voltage2	V <sub>UVLO2</sub>	8.0	9.0	10.0	V	VCC drop
VCC UVLO Hysteresis	V <sub>UVLO3</sub>	-	3.0	-	V	V <sub>UVLO3</sub> = V <sub>UVLO1</sub> - V <sub>UVLO2</sub>
<b>[Gm Amplifier Block]</b>						
VS Pin Pull-up Current	I <sub>VS</sub>	-	0.7	-	μA	
Gm Amplifier Reference Voltage 1	V <sub>AMP</sub>	2.465	2.500	2.535	V	
Gm Amplifier Line Regulation	V <sub>AMP_LINE</sub>	-20	-1	-	mV	VCC=10 V to 26 V
Gm Amplifier Trans Conductance	T <sub>VS</sub>	45	70	95	μA/V	EO=2.5 V V <sub>GUP</sub> < VS < V <sub>OVP</sub>
Gm Amplifier Source Current	I <sub>EO_SOURCE</sub>	30	50	70	μA	VS=1.0 V
Gm Amplifier Sink Current	I <sub>EO_SINK</sub>	30	50	70	μA	VS=3.5 V
<b>[EO Block]</b>						
Off Threshold Voltage	V <sub>OFF_TH</sub>	0.15	0.30	0.60	V	
EO Discharge Current	I <sub>EO</sub>	1	2	4	mA	VCC=11 V, EO=1.0 V
<b>[OSC Block]</b>						
Maximum ON Width1	t <sub>MAXDUTY1</sub>	8	10	12	μs	R <sub>RT</sub> =39 kΩ, EO=4.0 V
Maximum ON Width2	t <sub>MAXDUTY2</sub>	16	20	24	μs	R <sub>RT</sub> =120 kΩ, EO=4.0 V
Maximum ON Width3	t <sub>MAXDUTY3</sub>	24	30	36	μs	R <sub>RT</sub> =470 kΩ, EO=4.0 V
Maximum Frequency1	f <sub>MAXDUTY1</sub>	493	580	667	kHz	R <sub>RT</sub> =39 kΩ, EO=0.3 V
Maximum Frequency2	f <sub>MAXDUTY2</sub>	382	450	518	kHz	R <sub>RT</sub> =120 kΩ, EO=0.3 V
Maximum Frequency3	f <sub>MAXDUTY3</sub>	348	410	472	kHz	R <sub>RT</sub> =470 kΩ, EO=0.3 V
RT Output Voltage	V <sub>RT</sub>	0.9	1.2	1.8	V	R <sub>RT</sub> =120 kΩ
<b>[IS Block]</b>						
Zero Current Detection Voltage	V <sub>ZCD</sub>	-15	-10	-5	mV	
Zero Current Detection Voltage Delay	t <sub>ZCDD</sub>	0.65	1.35	2.05	μs	R <sub>RT</sub> =120 kΩ
IS Overcurrent Detection Voltage	V <sub>IS_OCP</sub>	-0.62	-0.60	-0.58	V	
Restart Timer	t <sub>REST</sub>	15	30	45	μs	IS = GND
<b>[VS Protection Block]</b>						
VS Short Protection Detection Voltage	V <sub>SHORT</sub>	0.200	0.300	0.400	V	
VS Shortstop Protection Detection Time	t <sub>VS_SH</sub>	50	150	300	μs	
VS Overvoltage Gain Increase Voltage	V <sub>OVP</sub>	1.025 x V <sub>AMP</sub>	1.050 x V <sub>AMP</sub>	1.075 x V <sub>AMP</sub>	V	
VS Overvoltage Protection Detection Voltage 1	V <sub>OVP1</sub>	1.075 x V <sub>AMP</sub>	1.090 x V <sub>AMP</sub>	1.105 x V <sub>AMP</sub>	V	VS rise
VS Overvoltage Protection Detection Voltage 2	V <sub>OVP2</sub>	1.020 x V <sub>AMP</sub>	1.040 x V <sub>AMP</sub>	1.060 x V <sub>AMP</sub>	V	VS drop
VS Overvoltage Protection Detection Voltage Hysteresis	V <sub>HYS</sub>	0.030 x V <sub>AMP</sub>	0.050 x V <sub>AMP</sub>	0.070 x V <sub>AMP</sub>	V	
VS Low Voltage Gain Increase Voltage	V <sub>GUP</sub>	0.840 x V <sub>AMP</sub>	0.900 x V <sub>AMP</sub>	0.960 x V <sub>AMP</sub>	V	
<b>[OVP Block]</b>						
OVP Detection Voltage 1	V <sub>OVP3</sub>	2.6	2.7	2.8	V	OVP rise
OVP Detection Voltage 2	V <sub>OVP4</sub>	2.5	2.6	2.7	V	OVP drop
OVP Detect Time	t <sub>OVP3</sub>	20	60	150	μs	
<b>[OUT Block]</b>						
OUT H Voltage	V <sub>POUTH</sub>	10.8	12.0	13.2	V	OUT=-20 mA
OUT L Voltage	V <sub>POUTL</sub>	-	-	1.00	V	OUT=+20 mA
OUT Pull-down Resistance	R <sub>PDOUT</sub>	75	100	125	kΩ	

Typical Performance Curves

(Reference data)

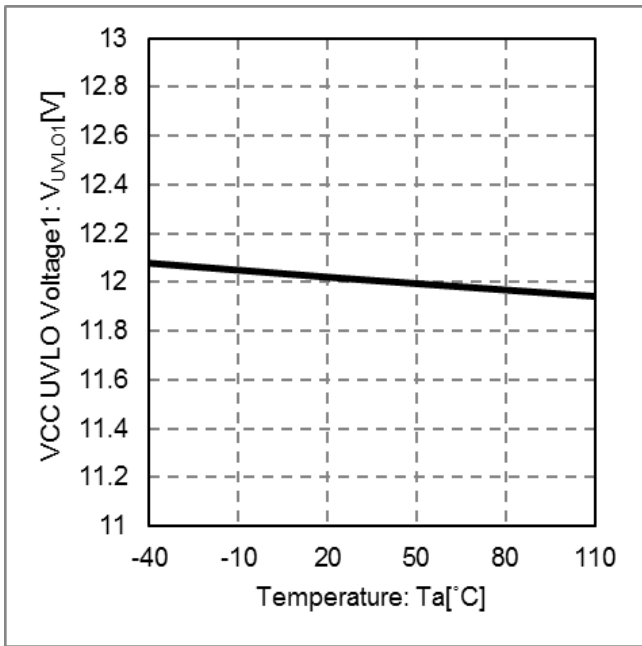

Figure 13. VCC UVLO Voltage1 vs Temperature

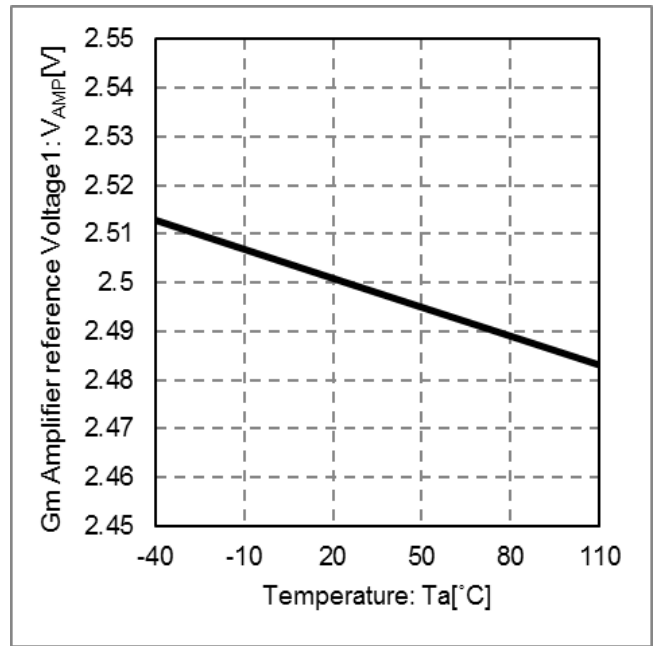

Figure 14. Gm Amplifier Reference Voltage1 vs Temperature

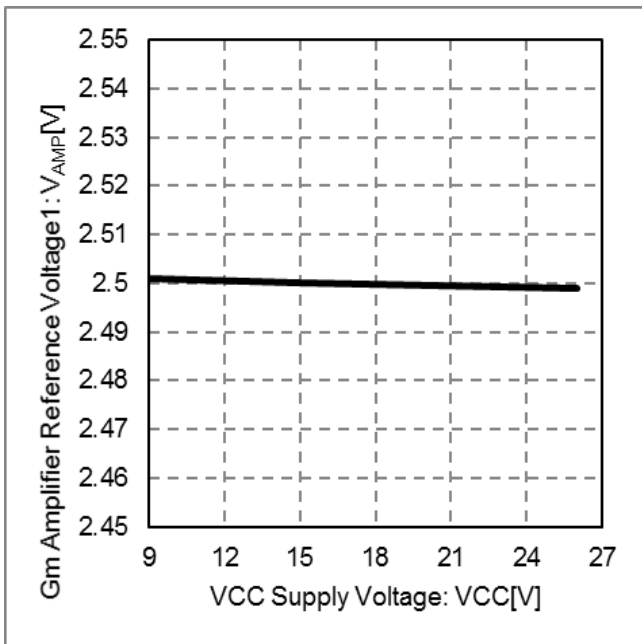

Figure 15. Gm Amplifier Reference Voltage1 vs VCC Supply Voltage

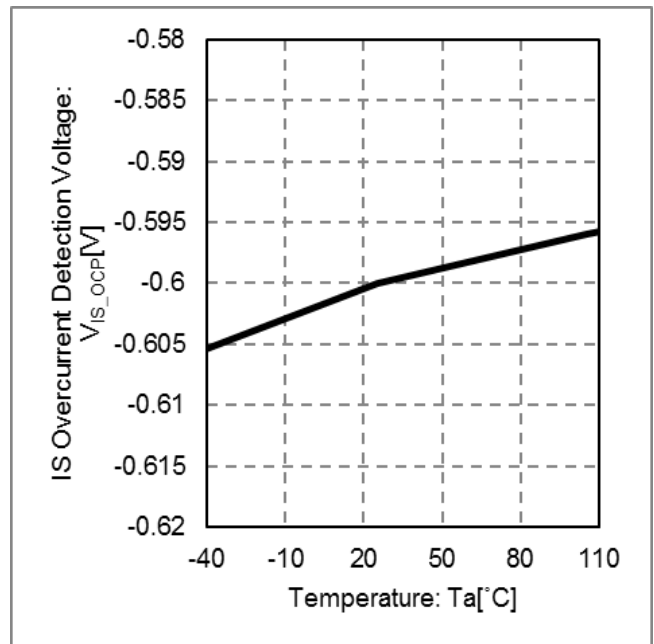

Figure 16. IS Overcurrent Detection Voltage vs Temperature

Typical Performance Curves - continued

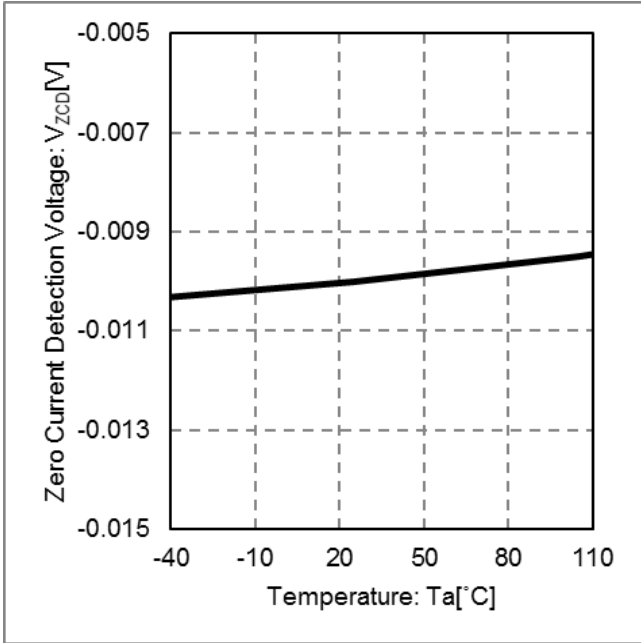

Figure 17. Zero Current Detection Voltage vs Temperature

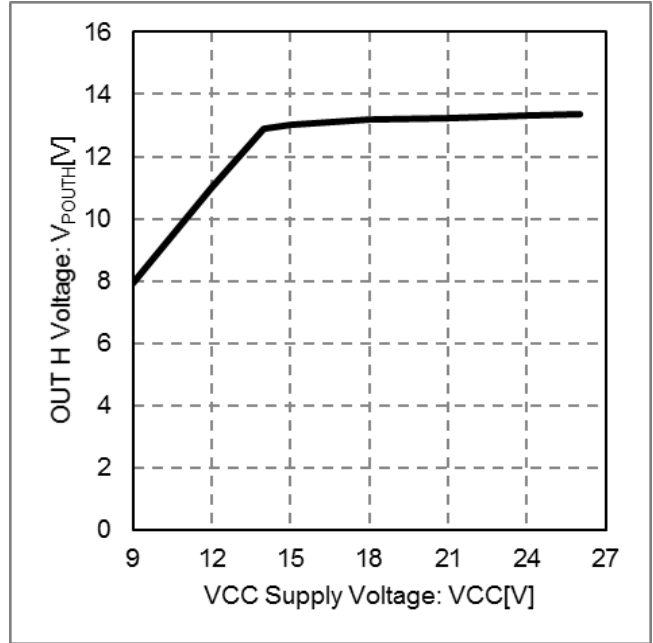

Figure 18. OUT H Voltage vs VCC Supply Voltage

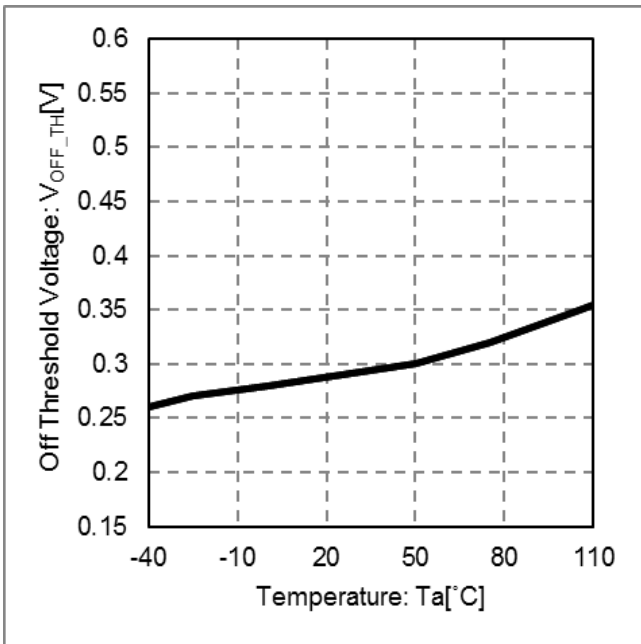

Figure 19. Off Threshold Voltage vs Temperature

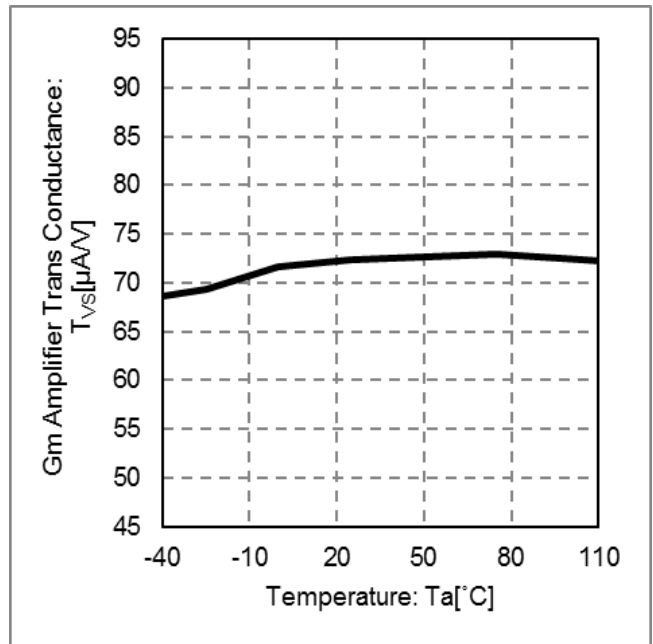

Figure 20. Gm Amplifier Trans Conductance vs Temperature

Timing Chart

The startup sequence is shown below.

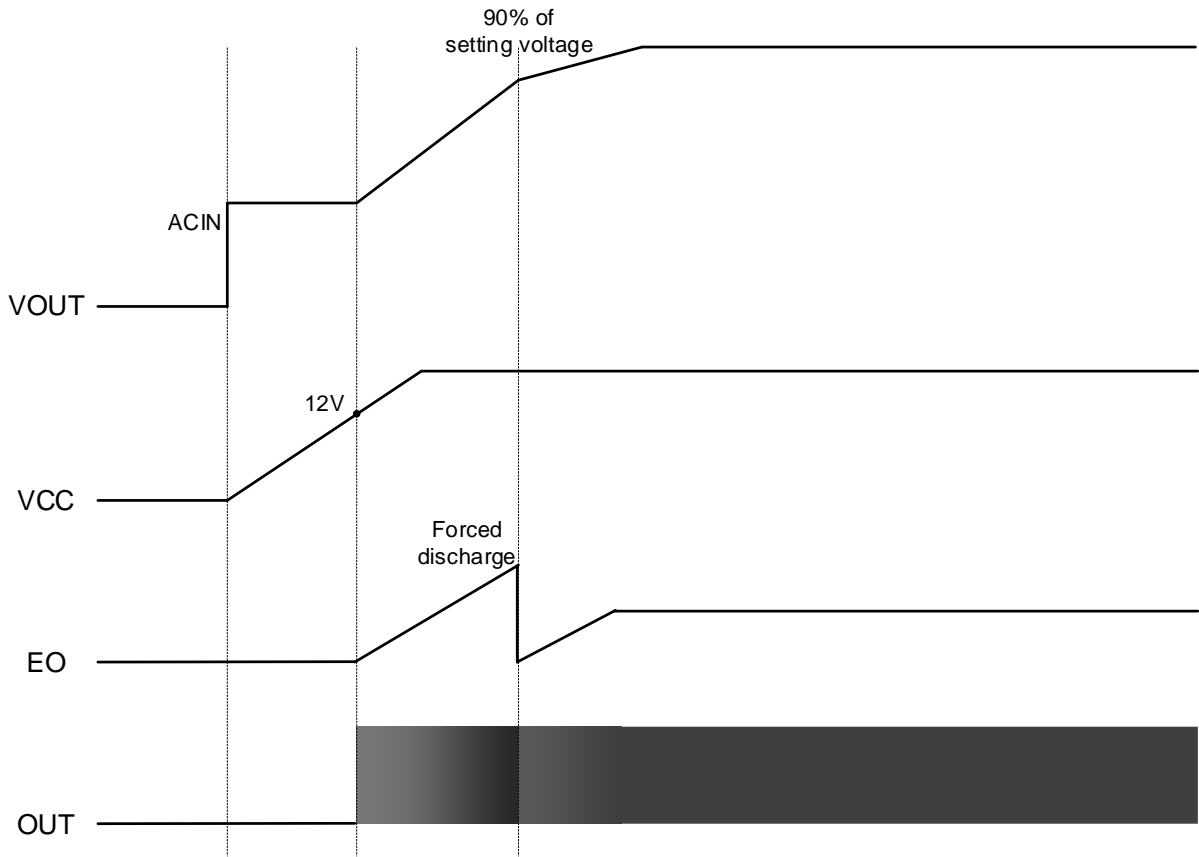

Figure 21. Startup Sequence

Application Example

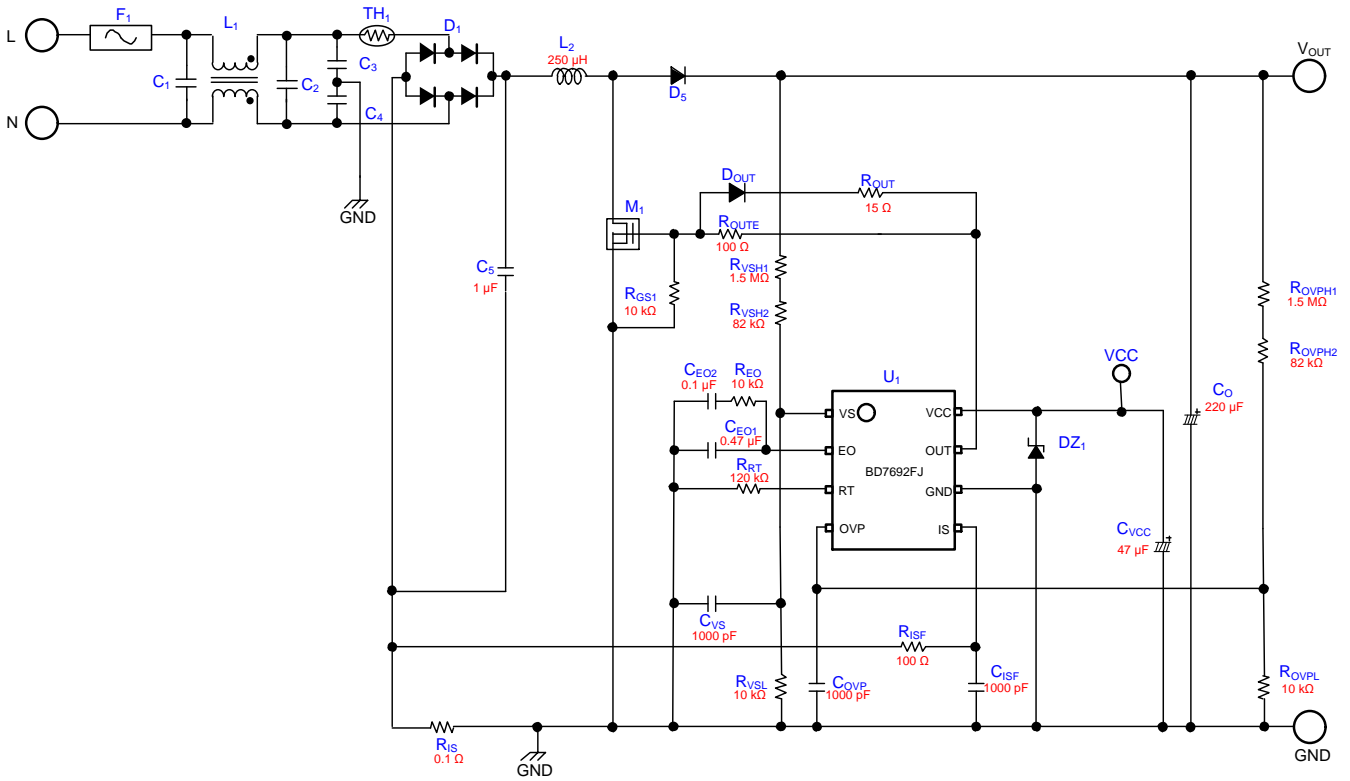

Figure 22. Application Example

## Application Example – continued

### 1 Output Voltage Setting

The output voltage is decided in resistor value of  $R_{VSH}$  and  $R_{VSL}$ .

$$V_{OUT} = \left(1 + \frac{R_{VSH}}{R_{VSL}}\right) \times V_{AMP} = \left(1 + \frac{1582 \text{ k}\Omega}{10 \text{ k}\Omega}\right) \times 2.5 \text{ V} = 398 \text{ [V]}$$

Where:

$R_{VSH}$  is the high side resistor value of output feedback line.

$R_{VSL}$  is the low side resistor value of output feedback line.

$V_{AMP}$  is the Gm Amplifier Reference Voltage 1

### 2 Decision of Minimum Frequency $f_{sw}$

The switching frequency of PFC

$$f_{SW} = \frac{\eta_{PFC} - V_{IN}^2}{2 \times P_{O\_PFC} \times L} \times \frac{V_{OUT} - \sqrt{2} \times V_{IN}}{V_{OUT}} \text{ [V]}$$

Where:

$V_{IN}$  is the input voltage.

$L$  is the inductance.

$P_{O\_PFC}$  is the maximum output power.

$\eta_{PFC}$  is the efficiency.

The frequency is minimized in the minimum input voltage. Slow frequency is effective about loss and noise. However, it is necessary to make inductance large when frequency is too slow. In addition, it enters the audible band when frequency lowers to 20 kHz or less, and sound banging occurs. It designs the minimum frequency as 50 kHz this time.

### 3 Calculation of the Inductance

$$L = \frac{\eta_{PFC} - V_{IN}^2}{2 \times P_{O\_PFC} \times f_{SW}} \times \frac{V_{OUT} - \sqrt{2} \times V_{IN}}{V_{OUT}} \text{ [V]}$$

e.g.  $V_{IN} = AC90 \text{ V}$ ,  $V_{OUT} = 400 \text{ V}$ ,  $P_{O\_PFC} = 200 \text{ W}$ ,  $\eta_{PFC} = 0.9$ ,  $f_{SW} = 50 \text{ kHz}$

$$L = 248.5 \text{ }\mu\text{H} \approx 250 \text{ [}\mu\text{H]}$$

### 4 Calculation of the Inductor Current

$$I_{PK} = \frac{\sqrt{2} \times V_{IN}}{L} \times t_{ON} = \frac{2\sqrt{2} \times P_{O\_PFC}}{\eta_{PFC} \times V_{IN}} = 6.98 \text{ [A]}$$

### 5 Calculation of the ON Width

$$t_{ON\_MAX} = \frac{2 \times L \times P_{O\_PFC}}{V_{INMIN}^2 \times \eta_{PFC}} \text{ [s]}$$

ON width is short at the high AC voltage. Therefore, the ON width is decided with the minimum AC voltage.

It recommends RT setting such as the maximum ON width is just covered at the minimum AC voltage when an AC input voltage range is wide. ON width is short when the high AC voltage. And the EO voltage range is small. EO voltage band width is the large then the ON width setting by the RT resistance is short.

### 6 VCC External Capacitor

The VCC pin can reduce VCC voltage change at the time of the switching by attaching capacitor.

This IC drives gate capacitor of the external MOSFET by the OUT pin. The VCC capacitor recommends electric field capacitor 10  $\mu\text{F}$  or more withstand pressure 35 V or more.

When the OUT pin outputs H, the gate capacitor charge current of the MOSFET flows from VCC in the OUT pin direction.

When there is not VCC capacitor, the VCC voltage descends. The VCC voltage descent may become the factor of a switching stop by the VCCUVLO detection and the unstable operation. In order to avoid this, VCC capacitor is necessary.

The VCC voltage descent depends on external MOSFET, operation frequency (output load) and the AC voltage.

Please confirm whether there is not VCC voltage descent which causes the VCCUVLO false detection at the time of MOSFET drive under the assumed situation with an actual board.

Attention in the Board Design

About parts placement

Please locate the parts in the Figure 23 inside dot line near the IC. In addition, please do parts placement to avoid the interference with switching lines and high current lines such as inductor, DRAIN.

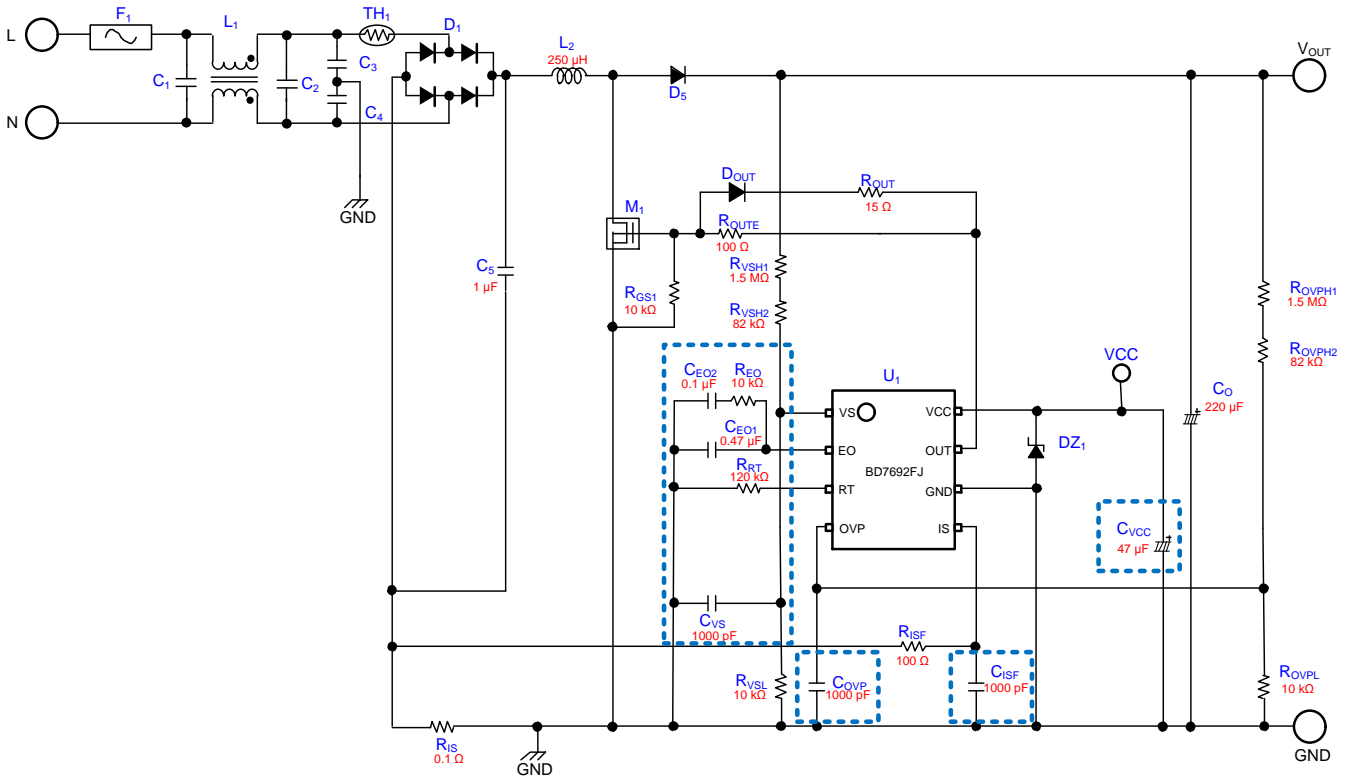

Figure 23. Parts Placement

About GND wiring guidance

The red line of Figure 24 is the GND lines which large current flows. Each line independence wires it, and please wire it short and thickly. A blue line is ICGND. Please make a common use ICGND and GND of IC around parts.

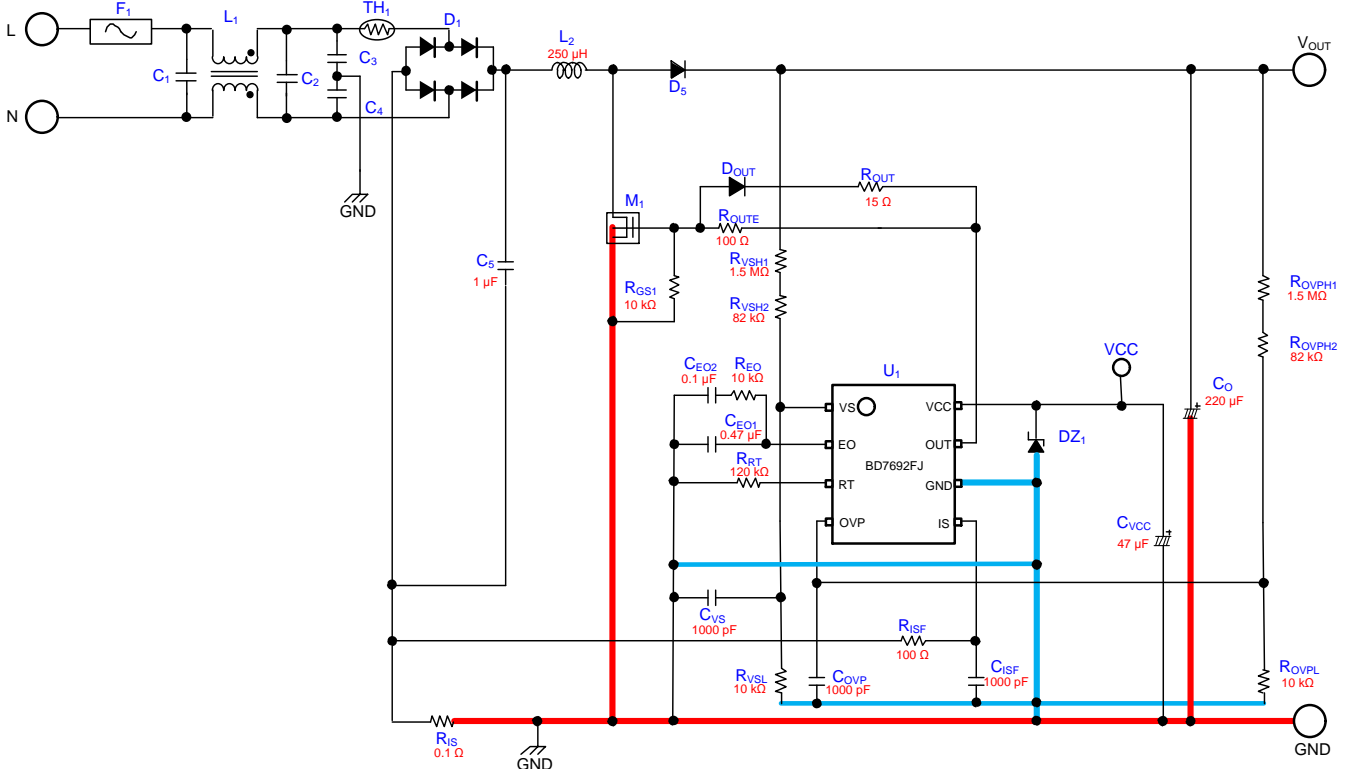

Figure 24. GND Line Layout



Attention in the Board - continued

About large current line

Large circuit current flows through the part of the red line of Figure 25. Please wire it short and thickly. Do not place IC and high impedance line near the red line because it has large noise.

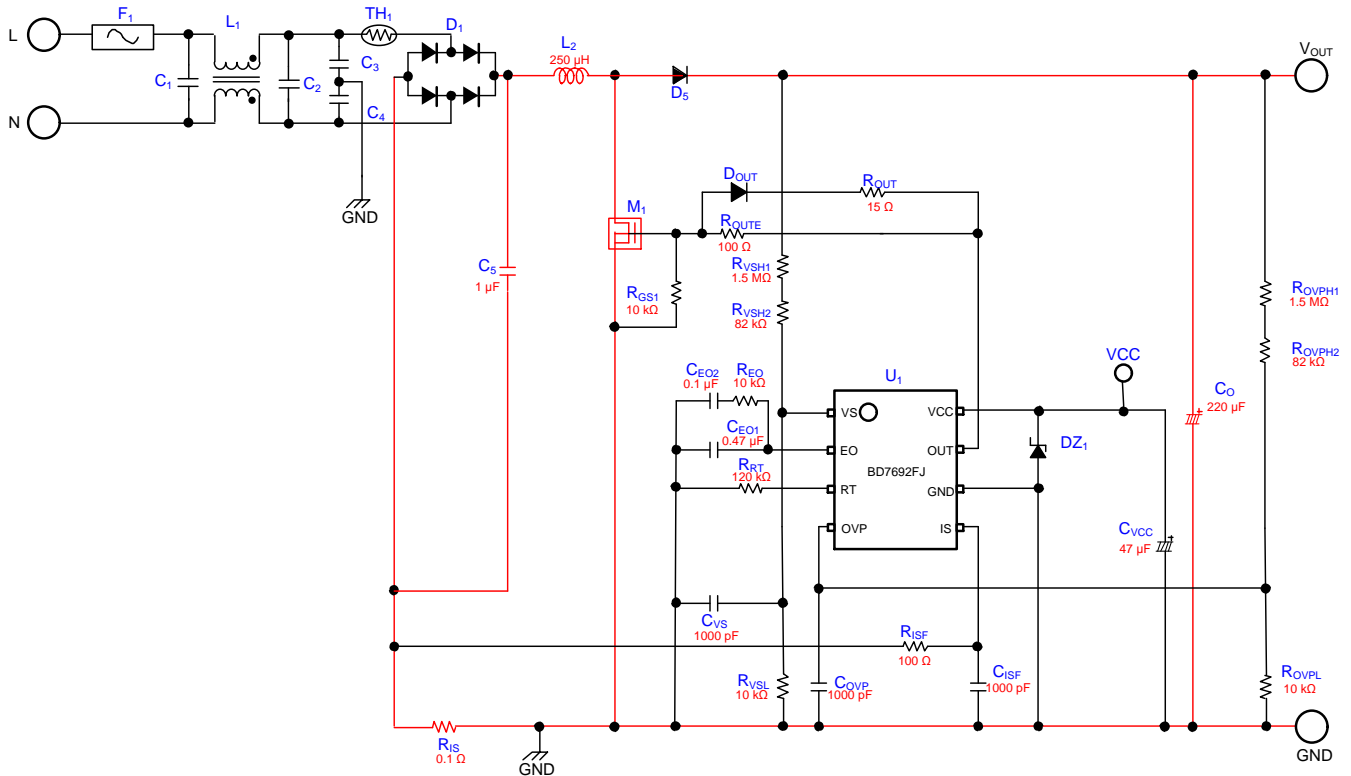

Figure 25. High Current Line Layout

I/O Equivalence Circuits

1	VS	2	EO	3	RT	4	OVP
5	IS	6	GND	7	OUT	8	VCC

## Operational Notes

### 1. Reverse Connection of Power Supply

Connecting the power supply in reverse polarity can damage the IC. Take precautions against reverse polarity when connecting the power supply, such as mounting an external diode between the power supply and the IC's power supply pins.

### 2. Power Supply Lines

Design the PCB layout pattern to provide low impedance supply lines. Furthermore, connect a capacitor to ground at all power supply pins. Consider the effect of temperature and aging on the capacitance value when using electrolytic capacitors.

### 3. Ground Voltage

Except for pins the output and the input of which were designed to go below ground, ensure that no pins are at a voltage below that of the ground pin at any time, even during transient condition.

### 4. Ground Wiring Pattern

When using both small-signal and large-current ground traces, the two ground traces should be routed separately but connected to a single ground at the reference point of the application board to avoid fluctuations in the small-signal ground caused by large currents. Also ensure that the ground traces of external components do not cause variations on the ground voltage. The ground lines must be as short and thick as possible to reduce line impedance.

### 5. Recommended Operating Conditions

The function and operation of the IC are guaranteed within the range specified by the recommended operating conditions. The characteristic values are guaranteed only under the conditions of each item specified by the electrical characteristics.

### 6. Inrush Current

When power is first supplied to the IC, it is possible that the internal logic may be unstable and inrush current may flow instantaneously due to the internal powering sequence and delays, especially if the IC has more than one power supply. Therefore, give special consideration to power coupling capacitance, power wiring, width of ground wiring, and routing of connections.

### 7. Testing on Application Boards

When testing the IC on an application board, connecting a capacitor directly to a low-impedance output pin may subject the IC to stress. Always discharge capacitors completely after each process or step. The IC's power supply should always be turned off completely before connecting or removing it from the test setup during the inspection process. To prevent damage from static discharge, ground the IC during assembly and use similar precautions during transport and storage.

### 8. Inter-pin Short and Mounting Errors

Ensure that the direction and position are correct when mounting the IC on the PCB. Incorrect mounting may result in damaging the IC. Avoid nearby pins being shorted to each other especially to ground, power supply and output pin. Inter-pin shorts could be due to many reasons such as metal particles, water droplets (in very humid environment) and unintentional solder bridge deposited in between pins during assembly to name a few.

### 9. Unused Input Pins

Input pins of an IC are often connected to the gate of a MOS transistor. The gate has extremely high impedance and extremely low capacitance. If left unconnected, the electric field from the outside can easily charge it. The small charge acquired in this way is enough to produce a significant effect on the conduction through the transistor and cause unexpected operation of the IC. So unless otherwise specified, unused input pins should be connected to the power supply or ground line.

## Operational Notes - continued

**10. Regarding the Input Pin of the IC**

This monolithic IC contains P+ isolation and P substrate layers between adjacent elements in order to keep them isolated. P-N junctions are formed at the intersection of the P layers with the N layers of other elements, creating a parasitic diode or transistor. For example (refer to figure below):

When  $GND > Pin A$  and  $GND > Pin B$ , the P-N junction operates as a parasitic diode.

When  $GND > Pin B$ , the P-N junction operates as a parasitic transistor.

Parasitic diodes inevitably occur in the structure of the IC. The operation of parasitic diodes can result in mutual interference among circuits, operational faults, or physical damage. Therefore, conditions that cause these diodes to operate, such as applying a voltage lower than the GND voltage to an input pin (and thus to the P substrate) should be avoided.

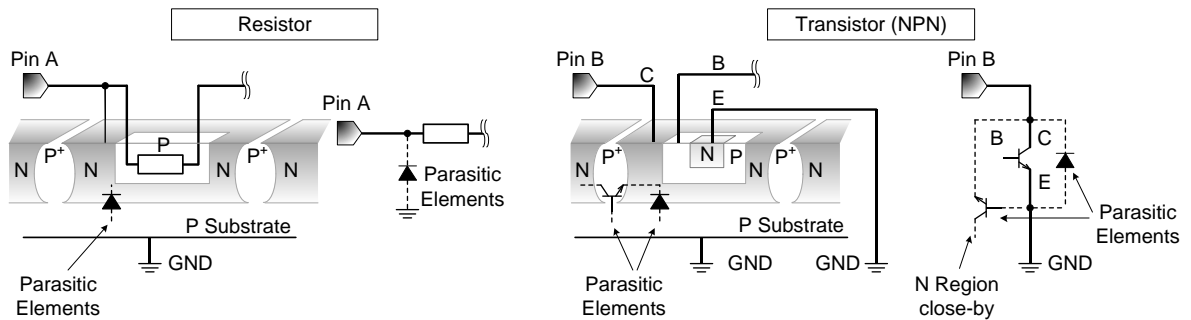

Figure 26. Example of monolithic IC structure

**11. Ceramic Capacitor**

When using a ceramic capacitor, determine a capacitance value considering the change of capacitance with temperature and the decrease in nominal capacitance due to DC bias and others.

**12. Thermal Shutdown Circuit(TSD)**

This IC has a built-in thermal shutdown circuit that prevents heat damage to the IC. Normal operation should always be within the IC's maximum junction temperature rating. If however the rating is exceeded for a continued period, the junction temperature ( $T_j$ ) will rise which will activate the TSD circuit that will turn OFF power output pins. When the  $T_j$  falls below the TSD threshold, the circuits are automatically restored to normal operation.

Note that the TSD circuit operates in a situation that exceeds the absolute maximum ratings and therefore, under no circumstances, should the TSD circuit be used in a set design or for any purpose other than protecting the IC from heat damage.

**13. Over Current Protection Circuit (OCP)**

This IC incorporates an integrated overcurrent protection circuit that is activated when the load is shorted. This protection circuit is effective in preventing damage due to sudden and unexpected incidents. However, the IC should not be used in applications characterized by continuous operation or transitioning of the protection circuit.

Ordering Information

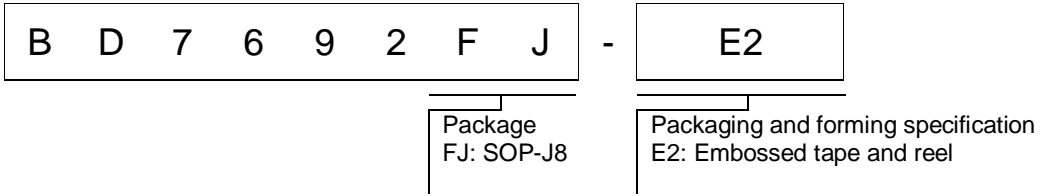

Marking Diagrams

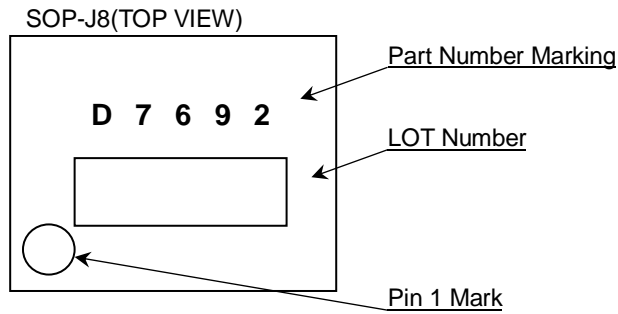

Physical Dimension and Packing Information

Package Name	SOP-J8
--------------	--------

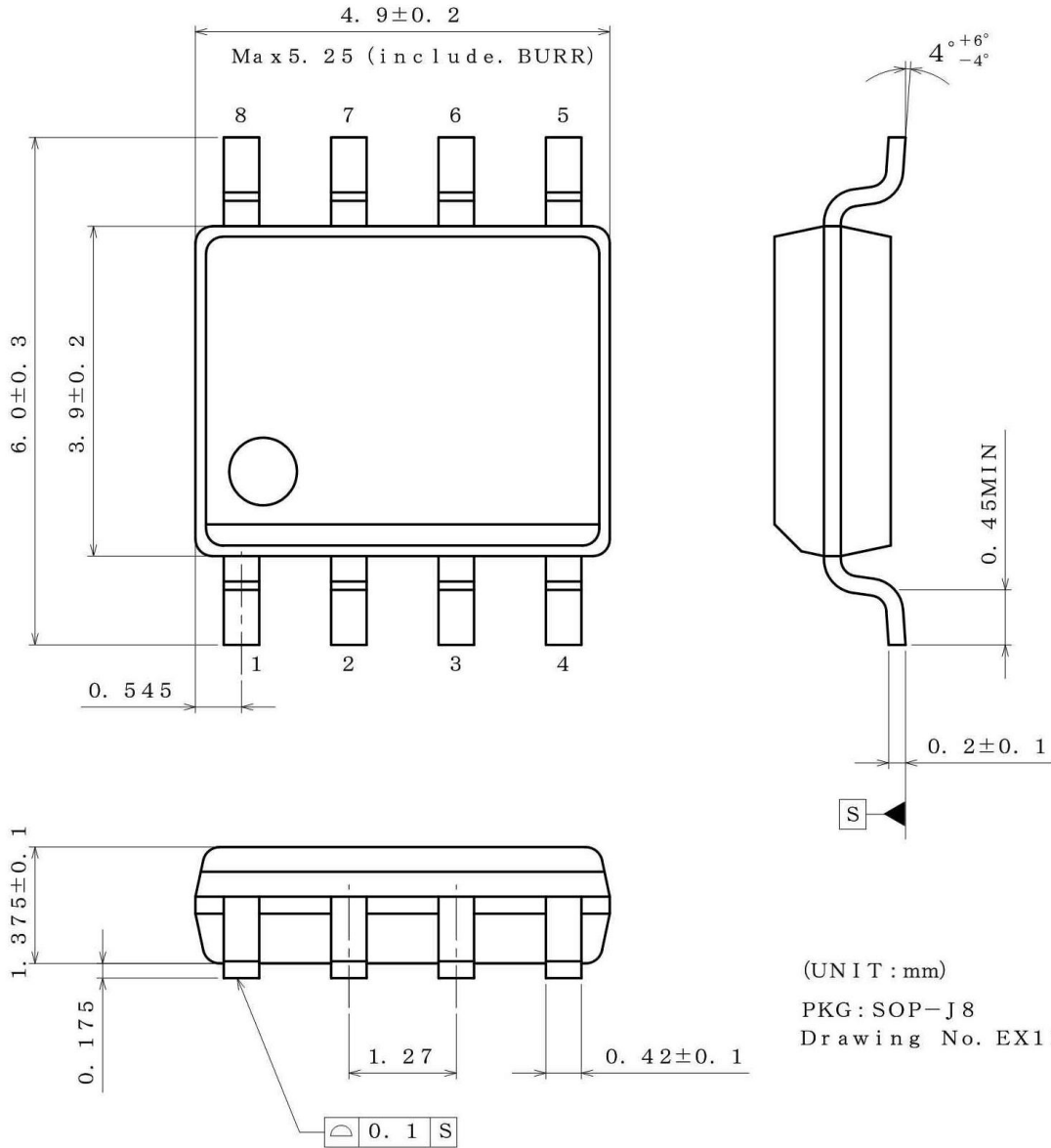

<Tape and Reel information>

Tape	Embossed carrier tape
Quantity	2500pcs
Direction of feed	E2 ( The direction is the 1pin of product is at the upper left when you hold reel on the left hand and you pull out the tape on the right hand )

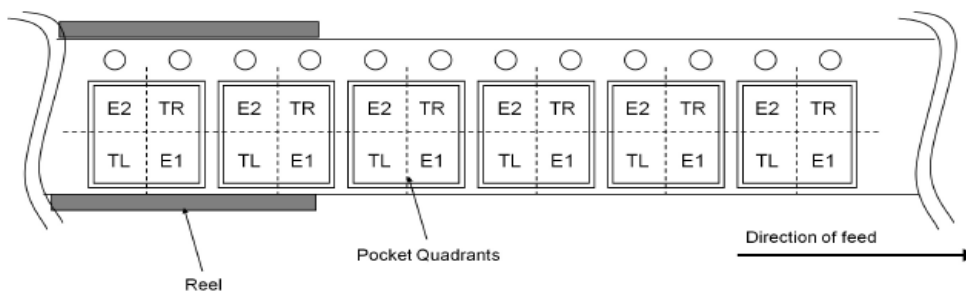

**Revision History**

Date	Revision	Changes
04.Oct.2018	001	Release

# Notice

## Precaution on using ROHM Products

- Our Products are designed and manufactured for application in ordinary electronic equipment (such as AV equipment, OA equipment, telecommunication equipment, home electronic appliances, amusement equipment, etc.). If you intend to use our Products in devices requiring extremely high reliability (such as medical equipment <sup>(Note 1)</sup>, transport equipment, traffic equipment, aircraft/spacecraft, nuclear power controllers, fuel controllers, car equipment including car accessories, safety devices, etc.) and whose malfunction or failure may cause loss of human life, bodily injury or serious damage to property ("Specific Applications"), please consult with the ROHM sales representative in advance. Unless otherwise agreed in writing by ROHM in advance, ROHM shall not be in any way responsible or liable for any damages, expenses or losses incurred by you or third parties arising from the use of any ROHM's Products for Specific Applications.

(Note1) Medical Equipment Classification of the Specific Applications

JAPAN	USA	EU	CHINA
CLASS III	CLASS III	CLASS II b	CLASS III
CLASS IV		CLASS III	

- ROHM designs and manufactures its Products subject to strict quality control system. However, semiconductor products can fail or malfunction at a certain rate. Please be sure to implement, at your own responsibilities, adequate safety measures including but not limited to fail-safe design against the physical injury, damage to any property, which a failure or malfunction of our Products may cause. The following are examples of safety measures:
  - Installation of protection circuits or other protective devices to improve system safety
  - Installation of redundant circuits to reduce the impact of single or multiple circuit failure
- Our Products are designed and manufactured for use under standard conditions and not under any special or extraordinary environments or conditions, as exemplified below. Accordingly, ROHM shall not be in any way responsible or liable for any damages, expenses or losses arising from the use of any ROHM's Products under any special or extraordinary environments or conditions. If you intend to use our Products under any special or extraordinary environments or conditions (as exemplified below), your independent verification and confirmation of product performance, reliability, etc. prior to use, must be necessary:
  - Use of our Products in any types of liquid, including water, oils, chemicals, and organic solvents
  - Use of our Products outdoors or in places where the Products are exposed to direct sunlight or dust
  - Use of our Products in places where the Products are exposed to sea wind or corrosive gases, including Cl<sub>2</sub>, H<sub>2</sub>S, NH<sub>3</sub>, SO<sub>2</sub>, and NO<sub>2</sub>
  - Use of our Products in places where the Products are exposed to static electricity or electromagnetic waves
  - Use of our Products in proximity to heat-producing components, plastic cords, or other flammable items
  - Sealing or coating our Products with resin or other coating materials
  - Use of our Products without cleaning residue of flux (even if you use no-clean type fluxes, cleaning residue of flux is recommended); or Washing our Products by using water or water-soluble cleaning agents for cleaning residue after soldering
  - Use of the Products in places subject to dew condensation
- The Products are not subject to radiation-proof design.
- Please verify and confirm characteristics of the final or mounted products in using the Products.
- In particular, if a transient load (a large amount of load applied in a short period of time, such as pulse. is applied, confirmation of performance characteristics after on-board mounting is strongly recommended. Avoid applying power exceeding normal rated power; exceeding the power rating under steady-state loading condition may negatively affect product performance and reliability.
- De-rate Power Dissipation depending on ambient temperature. When used in sealed area, confirm that it is the use in the range that does not exceed the maximum junction temperature.
- Confirm that operation temperature is within the specified range described in the product specification.
- ROHM shall not be in any way responsible or liable for failure induced under deviant condition from what is defined in this document.

## Precaution for Mounting / Circuit board design

- When a highly active halogenous (chlorine, bromine, etc.) flux is used, the residue of flux may negatively affect product performance and reliability.
- In principle, the reflow soldering method must be used on a surface-mount products, the flow soldering method must be used on a through hole mount products. If the flow soldering method is preferred on a surface-mount products, please consult with the ROHM representative in advance.

For details, please refer to ROHM Mounting specification

### Precautions Regarding Application Examples and External Circuits

1. If change is made to the constant of an external circuit, please allow a sufficient margin considering variations of the characteristics of the Products and external components, including transient characteristics, as well as static characteristics.
2. You agree that application notes, reference designs, and associated data and information contained in this document are presented only as guidance for Products use. Therefore, in case you use such information, you are solely responsible for it and you must exercise your own independent verification and judgment in the use of such information contained in this document. ROHM shall not be in any way responsible or liable for any damages, expenses or losses incurred by you or third parties arising from the use of such information.

### Precaution for Electrostatic

This Product is electrostatic sensitive product, which may be damaged due to electrostatic discharge. Please take proper caution in your manufacturing process and storage so that voltage exceeding the Products maximum rating will not be applied to Products. Please take special care under dry condition (e.g. Grounding of human body / equipment / solder iron, isolation from charged objects, setting of Ionizer, friction prevention and temperature / humidity control).

### Precaution for Storage / Transportation

1. Product performance and soldered connections may deteriorate if the Products are stored in the places where:
  - [a] the Products are exposed to sea winds or corrosive gases, including Cl<sub>2</sub>, H<sub>2</sub>S, NH<sub>3</sub>, SO<sub>2</sub>, and NO<sub>2</sub>
  - [b] the temperature or humidity exceeds those recommended by ROHM
  - [c] the Products are exposed to direct sunshine or condensation
  - [d] the Products are exposed to high Electrostatic
2. Even under ROHM recommended storage condition, solderability of products out of recommended storage time period may be degraded. It is strongly recommended to confirm solderability before using Products of which storage time is exceeding the recommended storage time period.
3. Store / transport cartons in the correct direction, which is indicated on a carton with a symbol. Otherwise bent leads may occur due to excessive stress applied when dropping of a carton.
4. Use Products within the specified time after opening a humidity barrier bag. Baking is required before using Products of which storage time is exceeding the recommended storage time period.

### Precaution for Product Label

A two-dimensional barcode printed on ROHM Products label is for ROHM's internal use only.

### Precaution for Disposition

When disposing Products please dispose them properly using an authorized industry waste company.

### Precaution for Foreign Exchange and Foreign Trade act

Since concerned goods might be fallen under listed items of export control prescribed by Foreign exchange and Foreign trade act, please consult with ROHM in case of export.

### Precaution Regarding Intellectual Property Rights

1. All information and data including but not limited to application example contained in this document is for reference only. ROHM does not warrant that foregoing information or data will not infringe any intellectual property rights or any other rights of any third party regarding such information or data.
2. ROHM shall not have any obligations where the claims, actions or demands arising from the combination of the Products with other articles such as components, circuits, systems or external equipment (including software).
3. No license, expressly or implied, is granted hereby under any intellectual property rights or other rights of ROHM or any third parties with respect to the Products or the information contained in this document. Provided, however, that ROHM will not assert its intellectual property rights or other rights against you or your customers to the extent necessary to manufacture or sell products containing the Products, subject to the terms and conditions herein.

### Other Precaution

1. This document may not be reprinted or reproduced, in whole or in part, without prior written consent of ROHM.
2. The Products may not be disassembled, converted, modified, reproduced or otherwise changed without prior written consent of ROHM.
3. In no event shall you use in any way whatsoever the Products and the related technical information contained in the Products or this document for any military purposes, including but not limited to, the development of mass-destruction weapons.
4. The proper names of companies or products described in this document are trademarks or registered trademarks of ROHM, its affiliated companies or third parties.



**General Precaution**

1. Before you use our Products, you are requested to carefully read this document and fully understand its contents. ROHM shall not be in any way responsible or liable for failure, malfunction or accident arising from the use of any ROHM's Products against warning, caution or note contained in this document.
2. All information contained in this document is current as of the issuing date and subject to change without any prior notice. Before purchasing or using ROHM's Products, please confirm the latest information with a ROHM sales representative.
3. The information contained in this document is provided on an "as is" basis and ROHM does not warrant that all information contained in this document is accurate and/or error-free. ROHM shall not be in any way responsible or liable for any damages, expenses or losses incurred by you or third parties resulting from inaccuracy or errors of or concerning such information.