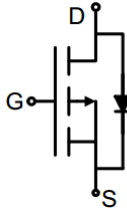
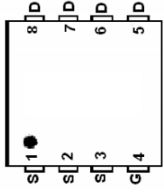
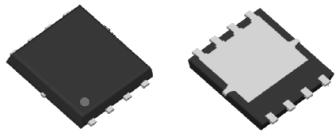

# P-Channel Enhancement Mode Power MOSFET

<p><b>Description</b></p> <p>The G35P04D5 uses advanced trench technology to provide excellent <math>R_{DS(ON)}</math>, low gate charge. It can be used in a wide variety of applications.</p> <p><b>General Features</b></p> <ul style="list-style-type: none"> <li>● <math>V_{DS}</math> -40V</li> <li>● <math>I_D</math> (at <math>V_{GS} = -10V</math>) -35A</li> <li>● <math>R_{DS(ON)}</math> (at <math>V_{GS} = -10V</math>) &lt; 14mΩ</li> <li>● <math>R_{DS(ON)}</math> (at <math>V_{GS} = -4.5V</math>) &lt; 20mΩ</li> <li>● 100% Avalanche Tested</li> <li>● RoHS Compliant</li> </ul> <p><b>Application</b></p> <ul style="list-style-type: none"> <li>● Power switch</li> <li>● DC/DC converters</li> </ul>		 <p>Schematic diagram</p>  <p>Marking and pin assignment</p>  <p>DFN5*6</p>	
<b>Device</b>	<b>Package</b>	<b>Marking</b>	<b>Packaging</b>
G35P04D5	DFN5*6	G35P04	5000pcs/Reel

## Absolute Maximum Ratings $T_C = 25^{\circ}C$ , unless otherwise noted

Parameter	Symbol	Value	Unit
Drain-Source Voltage	$V_{DS}$	-40	V
Continuous Drain Current	$I_D$	-35	A
Pulsed Drain Current (note1)	$I_{DM}$	-140	A
Gate-Source Voltage	$V_{GS}$	±20	V
Power Dissipation	$P_D$	35	W
Single pulse avalanche energy (note3)	$E_{AS}$	132	mJ
Operating Junction and Storage Temperature Range	$T_J, T_{stg}$	-55 To 150	°C

## Thermal Resistance

Parameter	Symbol	Value	Unit
Thermal Resistance, Junction-to-Case	$R_{thJC}$	3.6	°C/W

Specifications $T_J = 25^{\circ}\text{C}$ , unless otherwise noted						
Parameter	Symbol	Test Conditions	Value			Unit
			Min.	Typ.	Max.	
<b>Static Parameters</b>						
Drain-Source Breakdown Voltage	$V_{(BR)DSS}$	$V_{GS} = 0V, I_D = -250\mu A$	-40	--	--	V
Zero Gate Voltage Drain Current	$I_{DSS}$	$V_{DS} = -40V, V_{GS} = 0V$	--	--	-1	$\mu A$
Gate-Source Leakage	$I_{GSS}$	$V_{GS} = \pm 20V$	--	--	$\pm 100$	nA
Gate-Source Threshold Voltage	$V_{GS(th)}$	$V_{DS} = V_{GS}, I_D = -250\mu A$	-1.2	-1.5	-2.3	V
Drain-Source On-Resistance	$R_{DS(on)}$	$V_{GS} = -10V, I_D = -15A$	--	11	14	m $\Omega$
		$V_{GS} = -4.5V, I_D = -10A$	--	15	20	
Forward Transconductance	$g_{FS}$	$V_{DS} = -5V, I_D = -10A$	--	27	--	S
<b>Dynamic Parameters</b>						
Input Capacitance	$C_{iss}$	$V_{GS} = 0V,$ $V_{DS} = -20V,$ $f = 1.0MHz$	--	3280	--	pF
Output Capacitance	$C_{oss}$		--	343	--	
Reverse Transfer Capacitance	$C_{rss}$		--	285	--	
Total Gate Charge	$Q_g$	$V_{DD} = -20V,$ $I_D = -10A,$ $V_{GS} = -10V$	--	60	--	nC
Gate-Source Charge	$Q_{gs}$		--	8.2	--	
Gate-Drain Charge	$Q_{gd}$		--	11.6	--	
Turn-on Delay Time	$t_{d(on)}$	$V_{DD} = -20V,$ $I_D = -10A,$ $R_G = 3\Omega$	--	11	--	ns
Turn-on Rise Time	$t_r$		--	9	--	
Turn-off Delay Time	$t_{d(off)}$		--	24	--	
Turn-off Fall Time	$t_f$		--	12	--	
<b>Drain-Source Body Diode Characteristics</b>						
Body Diode Voltage	$V_{SD}$	$I_S = -15A, V_{GS} = 0V$	--	--	-1.2	V
Reverse Recovery Time	$T_{rr}$	$I_S = -20A, V_{GS} = 0V$ $di/dt = -100A/\mu s$	--	46	--	ns
Reverse Recovery Charge	$Q_{rr}$		--	27	--	nC

**Notes**

1. Repetitive Rating: Pulse width limited by maximum junction temperature
2. Identical low side and high side switch with identical  $R_G$
3. EAS condition :  $T_J = 25^{\circ}\text{C}, V_{DD} = -40V, V_G = -10V, L = 0.5mH, R_g = 25\Omega$

Gate Charge Test Circuit

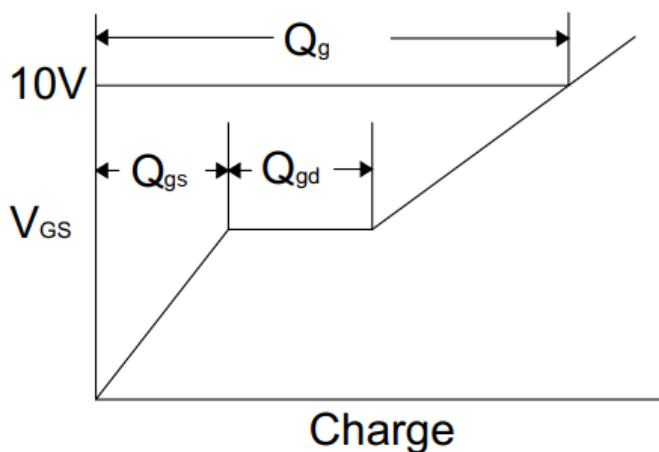
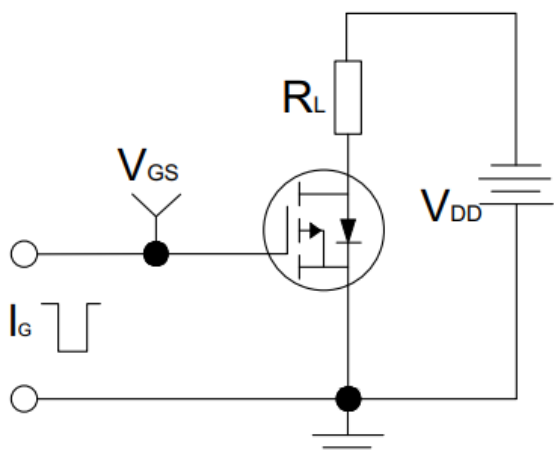

Switch Time Test Circuit

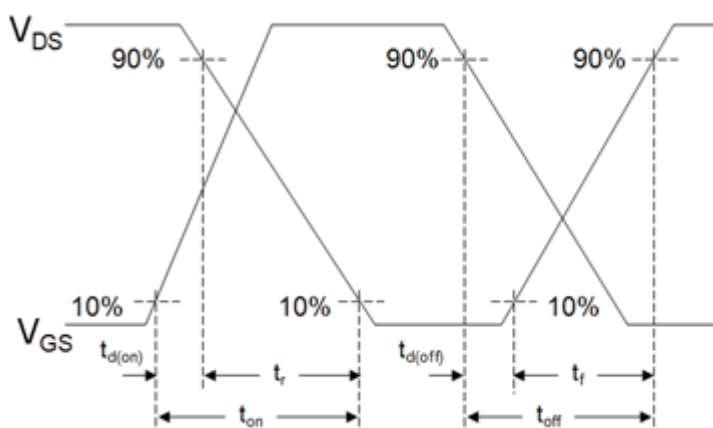
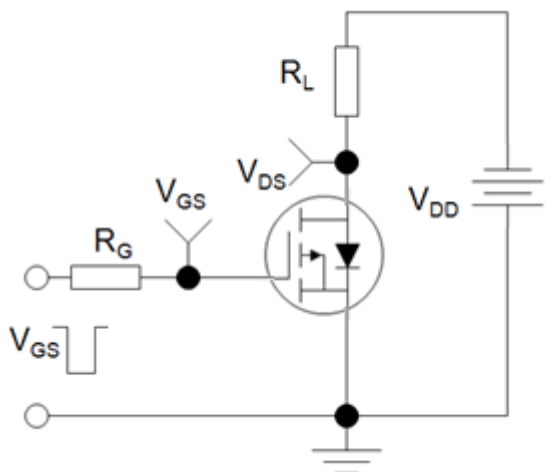

EAS Test Circuit

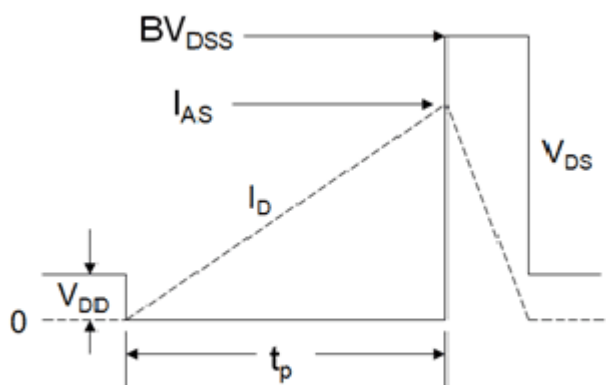
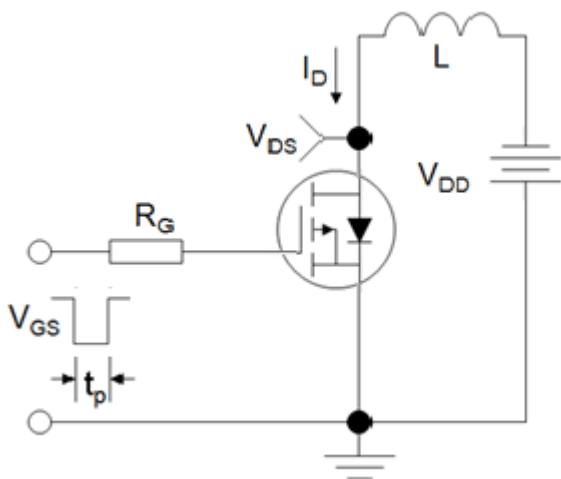

Typical Characteristics  $T_J = 25^\circ\text{C}$ , unless otherwise noted

Figure 1. Output Characteristics

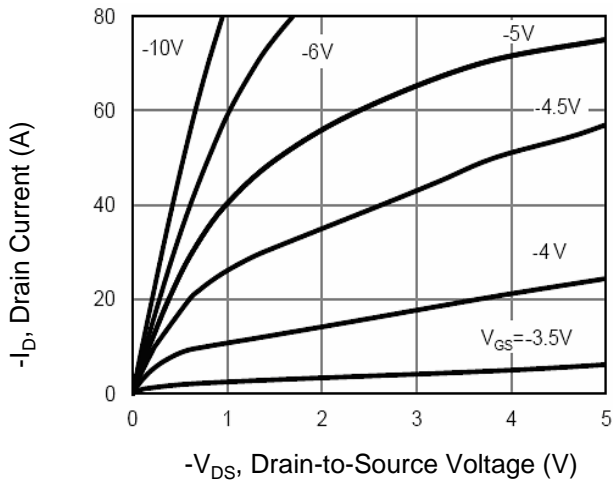

Figure 2. Transfer Characteristics

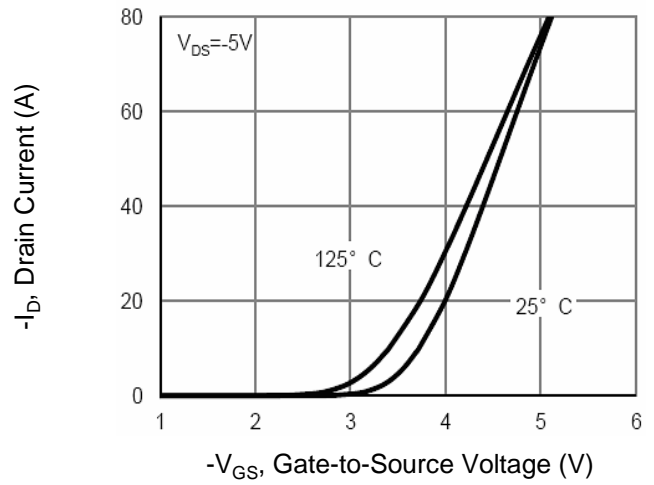

Figure 3. Drain Source On Resistance

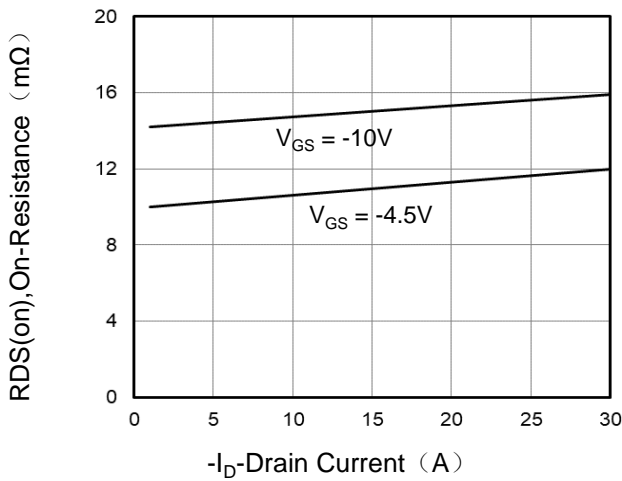

Figure 4. Gate Charge

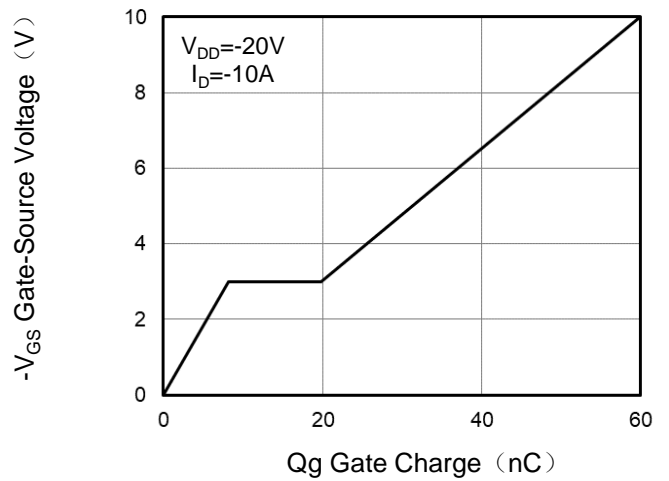

Figure 5. Capacitance vs Vds

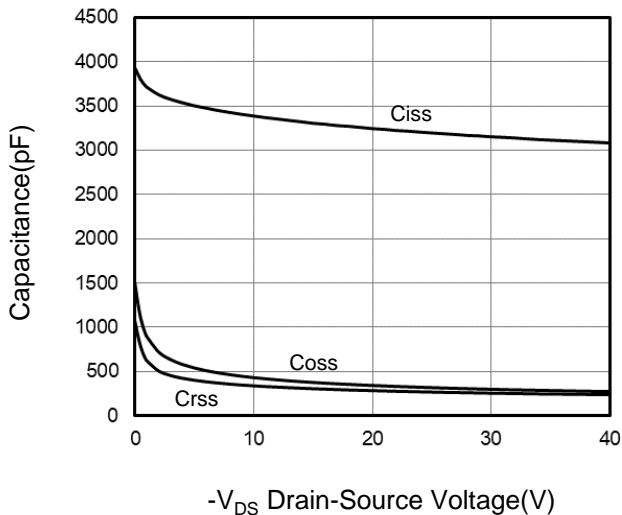
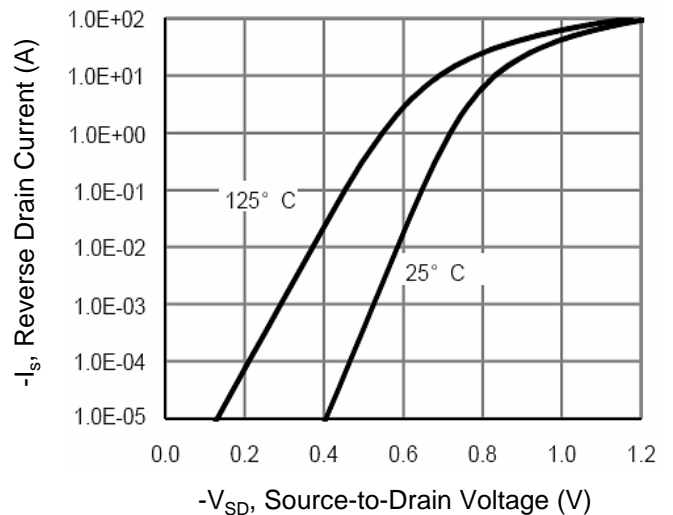

Figure 6. Source-Drain Diode Forward



Typical Characteristics  $T_J = 25^\circ\text{C}$ , unless otherwise noted

Figure 7. Drain-Source On-Resistance

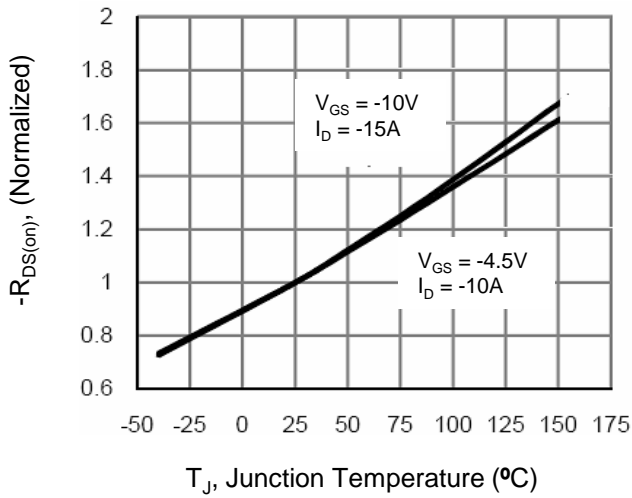

Figure 8. Safe Operation Area

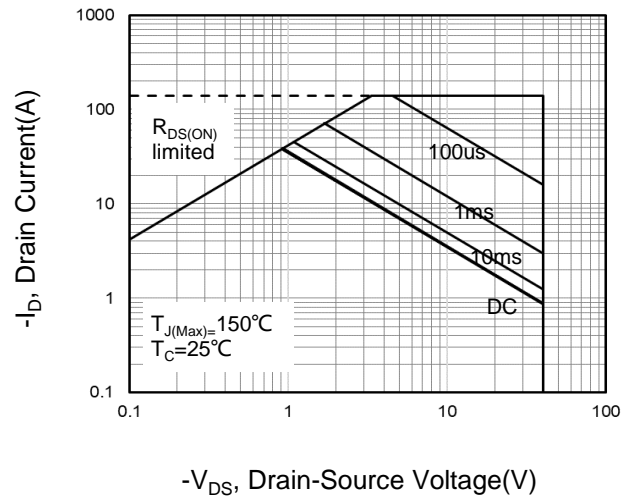
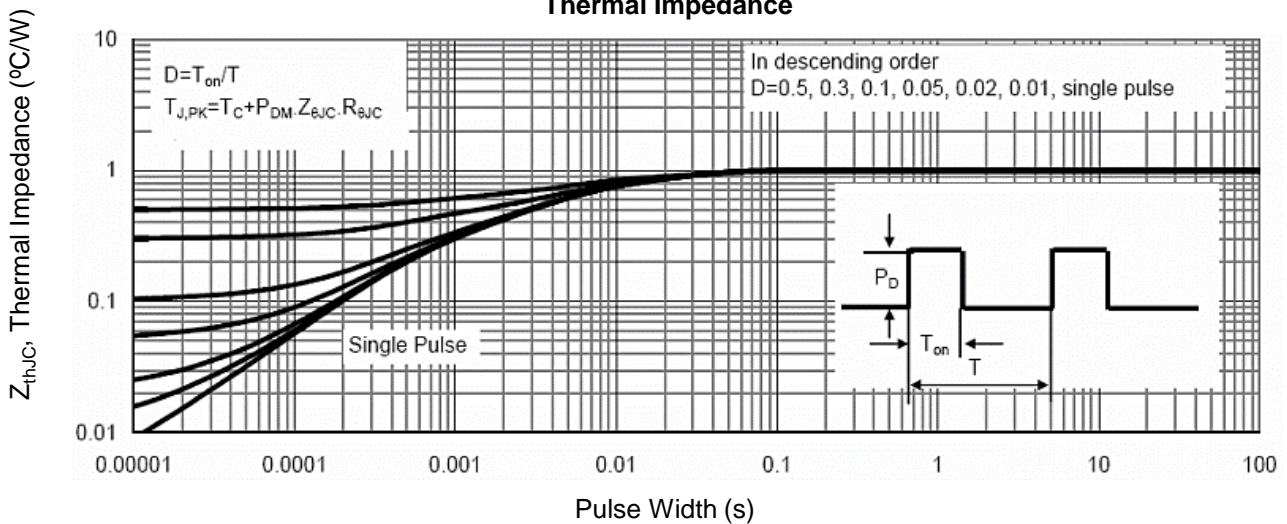
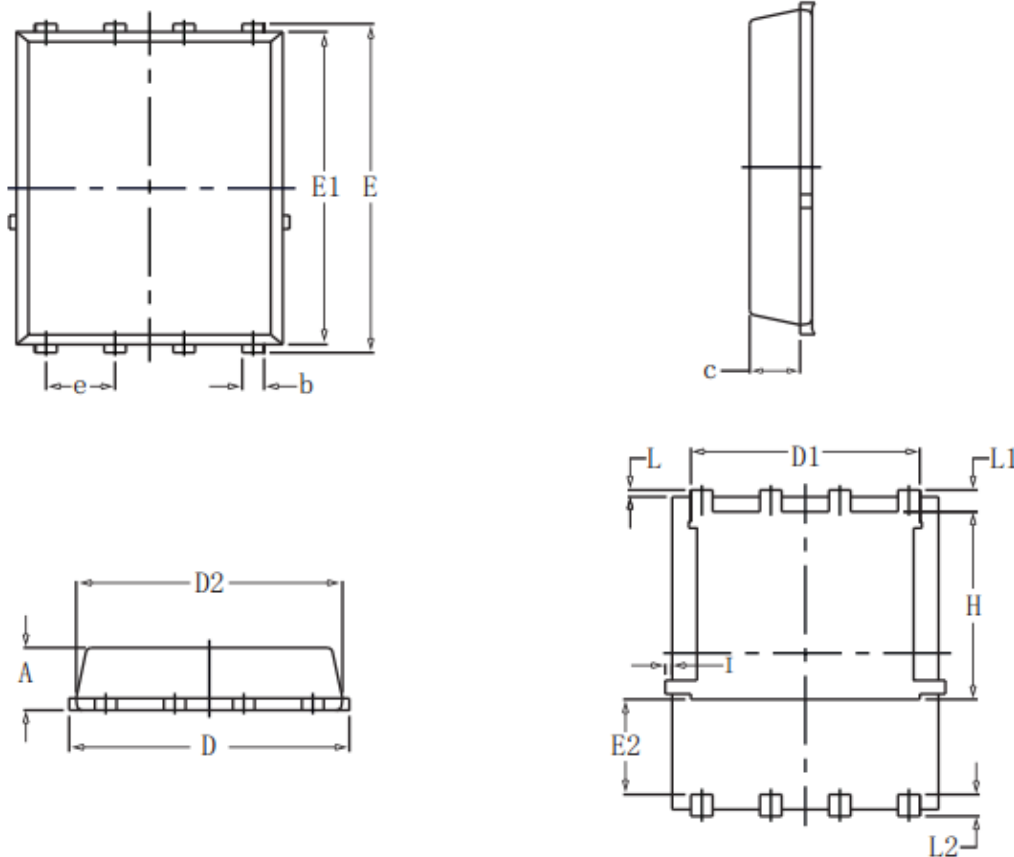

Figure 9. Normalized Maximum Transient Thermal Impedance



DFN5×6-8L Package Information



SYMBOL	COMMON			
	MM		INCH	
	MIN	MAX	MIN	MAX
A	1.03	1.17	0.0406	0.0461
b	0.34	0.48	0.0134	0.0189
c	0.824	0.970	0.0324	0.0382
D	4.80	5.40	0.1890	0.2126
D1	4.11	4.31	0.1618	0.1697
D2	4.80	5.00	0.1890	0.1969
E	5.59	6.15	0.2343	0.2421
E1	5.65	5.85	0.2224	0.2303
E2	1.60	-	0.0630	-
e	1.27 BSC		0.05 BSC	
L	0.05	0.25	0.0020	0.0098
L1	0.38	0.50	0.0150	0.0197
L2	0.38	0.50	0.0150	0.0197
H	3.30	3.50	0.1299	0.1378
I	-	0.18	-	0.0070