

1.5MHz, 30V, 1.2A Synchronous Step-Down Converter

Features

- Wide Input Range: 4.5V to 30V
- Feedback Voltage: 0.8V±2%
- 1.5MHz Switch Frequency
- Up to 1.2A Output Current
- Power Save Mode at Light Load
- COT control to achieve fast transient responses
- Integrated internal compensation
- Stable with Low ESR Ceramic Output Capacitors
- 250mΩ/120 mΩ Low $R_{DS(ON)}$ internal FETs
- Over Current Protection with Hiccup Mode
- Thermal Shutdown
- Inrush Current Limit and Soft Start
- Build in Input Over Voltage Protection
- Available in SOT23-6 Package

Description

The TMI3341 is a high efficiency 1.5MHz, synchronous step-down DC-DC converter capable of delivering up to 1.2A current. TMI3341 integrates both high and low side MOSFETs with low $R_{DS(ON)}$ to minimize the conduction loss. In light load condition, TMI3341 operates in PFM mode to provide high efficiency in light load mode. Low output voltage ripple and small external inductor and capacitor size are achieved with 1.5MHz switching frequency.

The TMI3341 requires a minimum number of readily available standard external components and is available in a 6-pin SOT23-6 ROHS compliant package.

Application

- Distributed Power Systems
- Flat Panel Television and Monitors
- Smart Home
- Industrial Power Systems

Typical Application

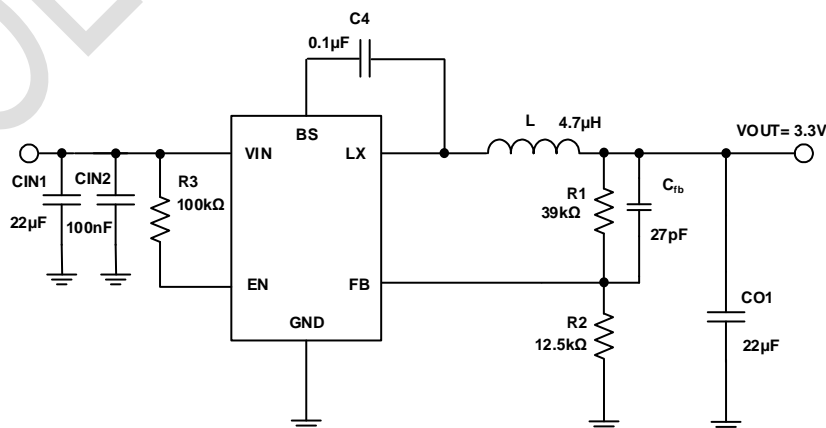

Absolute Maximum Ratings (Note 1)

Parameter	Min	Max	Unit
Input Supply Voltage	-0.3	32	V
Enable pin, EN	-0.3	V _{IN}	V
LX Voltages	-0.3	32	V
LX Voltages (<10ns transient)	-2.0	35	V
FB Voltage	-0.3	6	V
BS to LX Voltage	-0.3	6	V
Storage Temperature Range	-65	150	°C
Junction Temperature <small>(Note2)</small>	-	150	°C
Power Dissipation	-	1000	mW
Lead Temperature (Soldering, 10s)	-	260	°C

Package

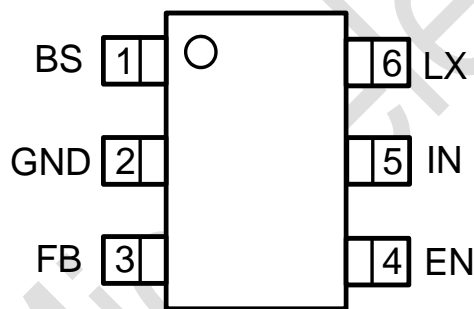

SOT23-6

Top Marking: TY1HXXX

TY1H: Device Code

XXX: Inside Code

Order Information

Part Number	Package	Top Marking	Quantity/Reel
TMI3341	SOT23-6	TY1HXXX	3000

TMI3341 devices are Pb-free and RoHS compliant.

Pin Functions

Pin	Name	Function
1	BS	Bootstrap. A capacitor connected between LX and BS pins is required to form a floating supply across the high-side switch driver.
2	GND	Ground Pin
3	FB	Output Voltage feedback input. Connect FB to the center point of the external resistor divider.
4	EN	Drive this pin to a logic-high to enable the IC. Drive to a logic-low to disable the IC and enter micro-power shutdown mode. Don't floating EN.
5	IN	Power supply Pin
6	LX	Switching Pin

ESD Rating

Items	Description	Value	Unit
V _{ESD_HBM}	Human Body Model for all pins	±2000	V
V _{ESD_CDM}	Charged Device Model for all pins	±2000	V

JEDEC specification JS-001

Recommended Operating Conditions

Items	Description	Min	Max	Unit
Voltage Range	IN	4.5	30	V
T _J	Operating Junction Temperature	-40	125	°C

Thermal Resistance (Note3)

Items	Description	Value	Unit
θ _{JA}	Junction-to-ambient thermal resistance	120	°C/W
θ _{JC}	Junction-to-case(top) thermal resistance	45	°C/W

Electrical Characteristics

$V_{IN}=12V$, $V_{OUT}=3.3V$, $T_A = 25^{\circ}C$, unless otherwise noted.

Parameter	Conditions	Min	Typ	Max	Unit
Input Voltage Range		4.5		30	V
OVP Threshold			31.5		V
UVLO Rising Threshold			4.3	4.5	V
UVLO Hysteresis			0.3		V
Quiescent Current	$V_{EN}=2V$, $V_{FB}=V_{REF} \times 105\%$		350	500	μA
Shutdown Current	$V_{IN}=12V$, $EN=0V$		5	10	μA
Regulated Feedback Voltage	$T_A=25^{\circ}C$	0.784	0.8	0.816	V
FB Input Leakage Current		-0.5		0.5	μA
High-Side Switch On-Resistance			250		m Ω
Low-Side Switch On-Resistance			120		m Ω
LX Leakage Current	$V_{EN}=0V$, $V_{LX}=0V$	1		10	μA
Switch Current Limit	Minimum Duty Cycle		2.7		A
Oscillation Frequency		1.2	1.5	1.8	MHz
Maximum Duty Cycle			78		%
Minimum On-Time			100		ns
Minimum Off-Time			125		ns
Soft Start Time		0.5	0.7	1.0	ms
Hiccup on Time			1		ms
Hiccup Time Before Restart			4.5		ms
EN Rising Threshold		0.85	1.1	1.3	V
EN Hysteresis			150		mV
EN Enable Delay Time (Note 4)			180		μs
EN Input Leakage Current	$V_{EN}=2V$	-1		1	μA
Thermal Shutdown Threshold (Note 4)			165		$^{\circ}C$
Thermal Shutdown Hysteresis (Note 4)			15		$^{\circ}C$

Note 1: Absolute Maximum Ratings are those values beyond which the life of a device may be impaired.

Note 2: T_J is calculated from the ambient temperature T_A and power dissipation P_D according to the following formula: $T_J = T_A + P_D \times \theta_{JA}$. The maximum allowable continuous power dissipation at any ambient temperature is calculated by $P_{D(MAX)} = (T_{J(MAX)} - T_A) / \theta_{JA}$.

Note 3: Measured on JESD51-7, 4-layer PCB.

Note 4: Guaranteed by design.

Block Diagram

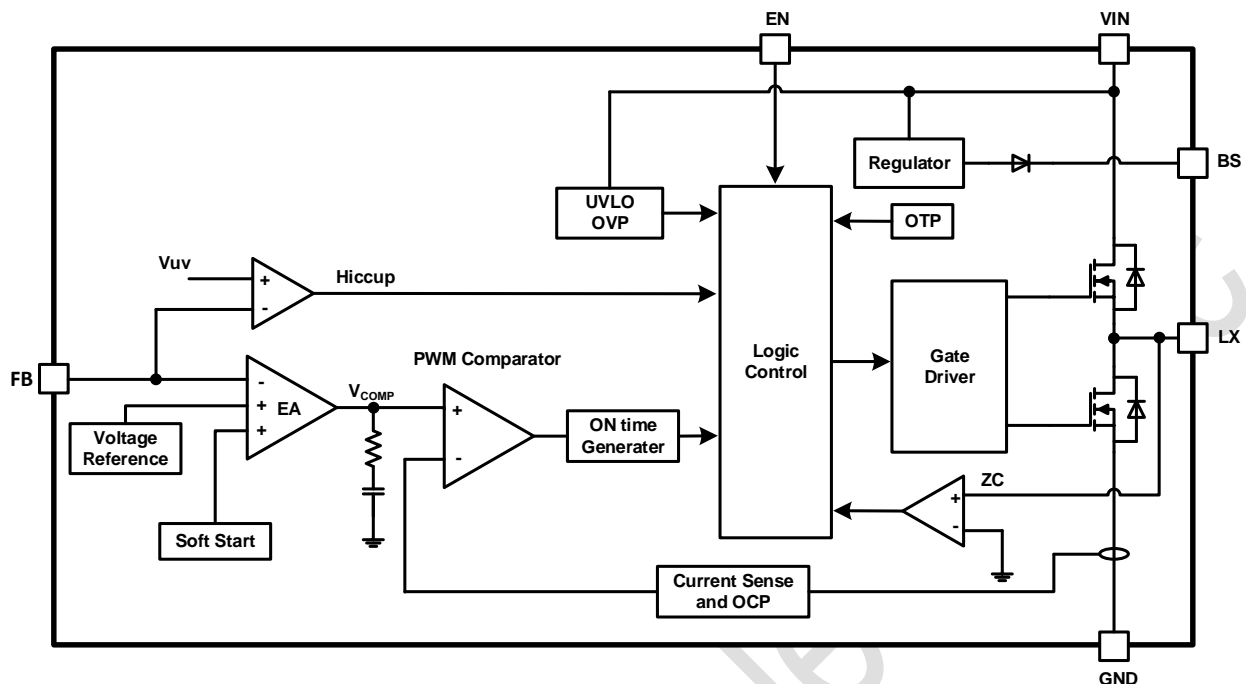

Figure 1. TMI3341 Block Diagram

Operation Description

Internal Regulator

The TMI3341 is a synchronous step down DC/DC converter with COT (constant on time) control that provides excellent transient response with no extra external compensation components. This device contains low resistance, high voltage high side power MOSFETs, and operates at 1.5MHz operating frequency with PFM in light load condition to ensure a compact, high efficiency design with excellent AC and DC performance.

Internal Soft-Start

The soft-start is implemented to prevent the converter output voltage from overshooting during startup. When the chip starts, the internal circuitry generates a soft-start voltage (SS) ramping up from 0V to V_{REF} . When it is lower than the internal FB reference (V_{REF}), SS overrides REF so the error amplifier uses SS as the reference. When SS is higher than V_{REF} , V_{REF} regains control. The SS time is internally fixed to 0.7ms typically.

Over-Current-Protection and Short Circuits Protection

The TMI3341 has cycle-by-cycle valley current limit function. When the inductor current value is larger than the current limit during MOSFET on state, the device enters into over current protection mode and MOSFET keeps on state until inductor current drops down to the value equal or lower than the current limit, and then high side MOSFET could turn on again.

If the output is short to GND and the output voltage drop until feedback voltage V_{FB} is below the output under-voltage V_{UV} threshold which is typically 50% of V_{REF} , TMI3341 enters into hiccup mode to

periodically disable and restart switching operation. The hiccup mode helps to reduce power dissipation and thermal rise during output short condition. The period of TMI3341 hiccup mode is typically 5.5ms.

Startup and Shutdown

If both VIN and EN are higher than their appropriate thresholds, the chip starts switching operation. The reference block starts first, generating stable reference voltage and currents, and then the internal regulator is enabled. The regulator provides stable supply for the remaining circuitries. Three events can shut down the chip: EN low, VIN low and thermal shutdown. In the shutdown procedure, the signaling path is first blocked to avoid any fault triggering. The V_{COMP} voltage and the internal supply rail are then pulled down. The floating driver is not subject to this shutdown command.

Application Information

Setting the Output Voltage

The external resistor divider is used to set the output voltage (see Typical Application on page 1). Choose R1 to be around 39kΩ for optimal transient response. R2 is then given by:

Table 1: Selection for Common Output Voltages (V_{FB}=0.8V)

V _{OUT} (V)	R1 (kΩ)	R2 (kΩ)	C _{FB} (pF)	L (μH)
12	39	2.74	27	10
5	39	7.43	27	4.7
3.3	39	12.5	27	4.7

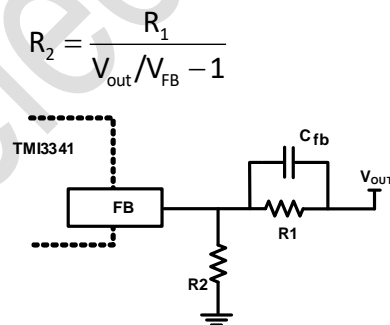

Figure 2. Feedback Network

TMI3341 adopts COT control mode with 1.5MHz high switching frequency. The minimum off time of TMI3341 is 100ns, so the minimum duty cycle with 1.5MHz switching frequency is 15%. When the operation duty cycle is lower than 15%, the switching frequency reduce. The recommended operation duty cycle is the range of 10% to 78%.

Selecting the Inductor

An inductor with a DC current rating of at least 25% percent higher than the maximum load current is recommended for most applications. For highest efficiency, the inductor DC resistance should be as small as possible. For most designs, the inductance value can be derived from the following equation.

$$L = \frac{V_{out} \times (V_{in} - V_{out})}{V_{in} \times \Delta I_L \times f_{OSC}}$$

Where Δ_L is the inductor ripple current. Choose inductor ripple current to be approximately 30% if the maximum load current 1.2A. The maximum inductor peak current is:

$$I_{L(MAX)} = I_{LOAD} + \frac{\Delta I_L}{2}$$

Under light load conditions below 100mA, larger inductance is recommended for improved efficiency.

Selecting the Output Capacitor

The output capacitor (Co1) is required to maintain the DC output voltage. Ceramic, tantalum, or low ESR electrolytic capacitors are recommended. Low ESR capacitors are preferred to keep the output voltage ripple low. The output voltage ripple can be estimated by:

$$\Delta V_{OUT} = \frac{V_{OUT}}{f_s \times L} \times \left[1 - \frac{V_{OUT}}{V_{IN}} \right] \times \left[R_{ESR} + \frac{1}{8 \times f_s \times C_2} \right]$$

Where L is the inductor value and R_{ESR} is the equivalent series resistance (ESR) value of the output capacitor. In the case of ceramic capacitors, the impedance at the switching frequency is dominated by the capacitance. The output voltage ripple is mainly caused by the capacitance. For simplification, the output voltage ripple can be estimated by:

$$\Delta V_{OUT} = \frac{V_{OUT}}{8 \times f_s^2 \times L \times C_2} \times \left[1 - \frac{V_{OUT}}{V_{IN}} \right]$$

In the case of tantalum or electrolytic capacitors, the ESR dominates the impedance at the switching frequency. For simplification, the output ripple can be approximated to:

$$\Delta V_{OUT} = \frac{V_{OUT}}{f_s \times L} \times \left[1 - \frac{V_{OUT}}{V_{IN}} \right] \times R_{ESR}$$

The characteristics of the output capacitor also affect the stability of the regulation system. The TMI3341 can be optimized for a wide range of capacitance and ESR values. 22μF or larger output capacitance is recommended for almost application. Because of DC derating of ceramic capacitor, the output capacitor DC voltage rating and package size must be considered in high output voltage application.

Typical Performance Characteristics

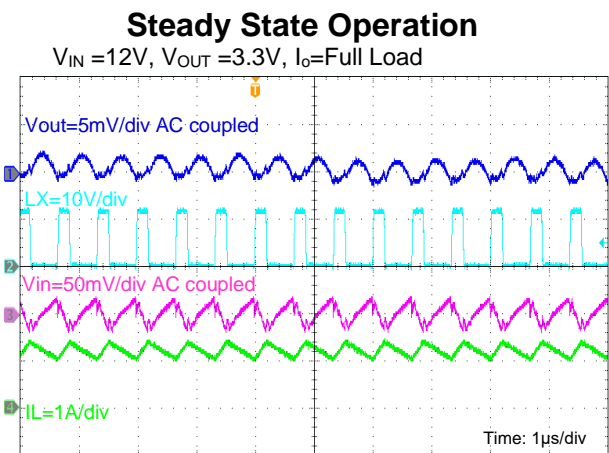
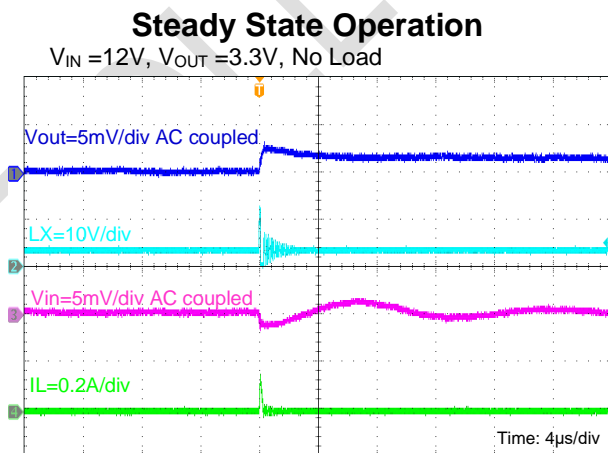
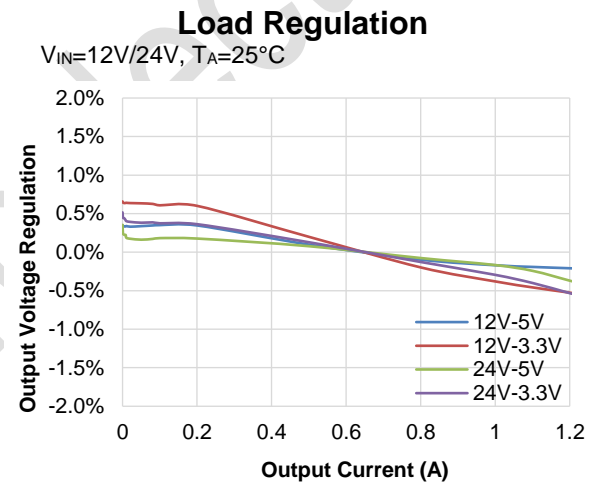
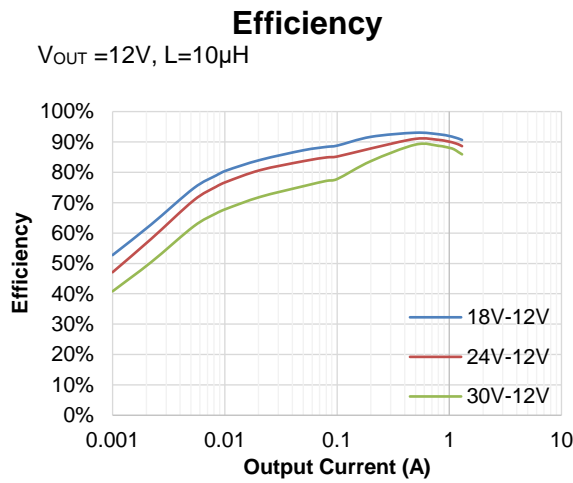
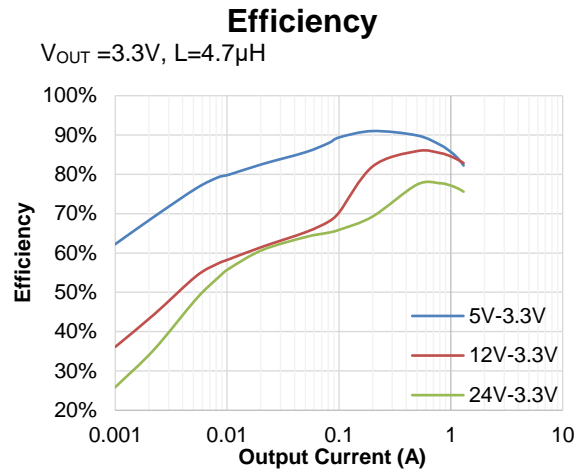
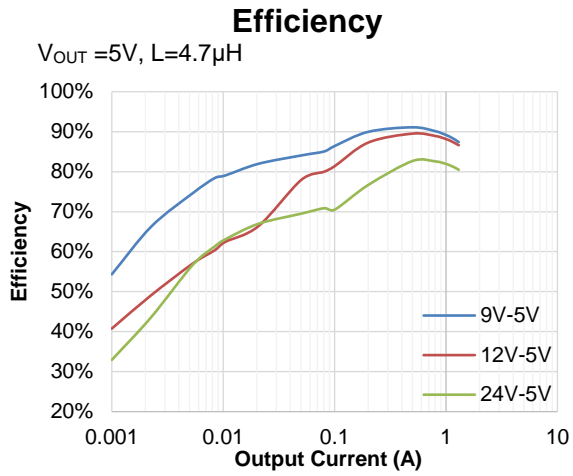

Typical Performance Characteristics(continued)

Load Transient

$V_{IN} = 12V, V_{OUT} = 3.3V, I_o = 0A \text{ to } 0.6A$

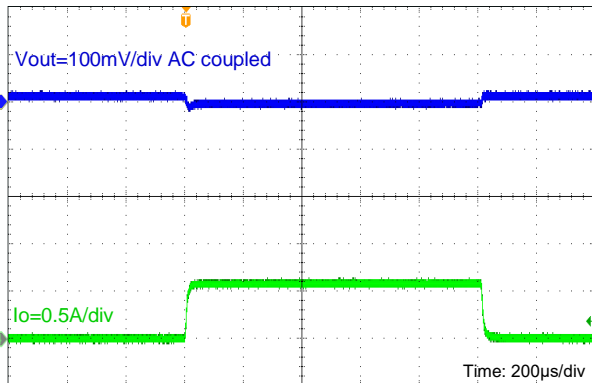

Load Transient

$V_{IN} = 12V, V_{OUT} = 3.3V, I_o = 0.6A \text{ to } 1.2A$

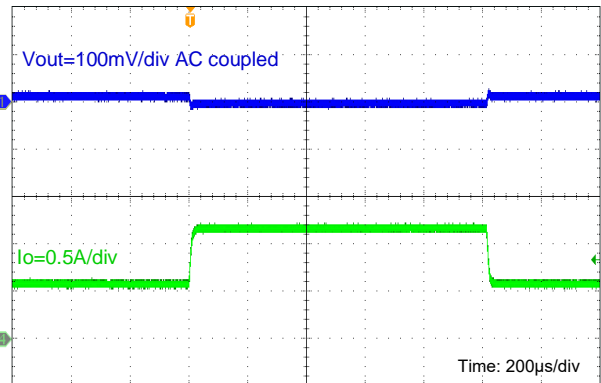

Output Short Entry

$V_{IN} = 12V, V_{OUT} = 3.3V, \text{No Load}$

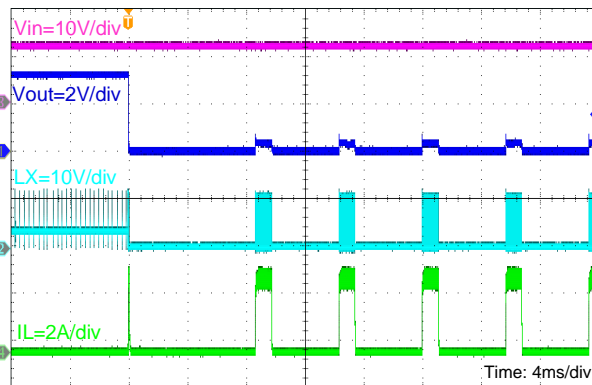

Output Short Recovery

$V_{IN} = 12V, V_{OUT} = 3.3V, \text{No Load}$

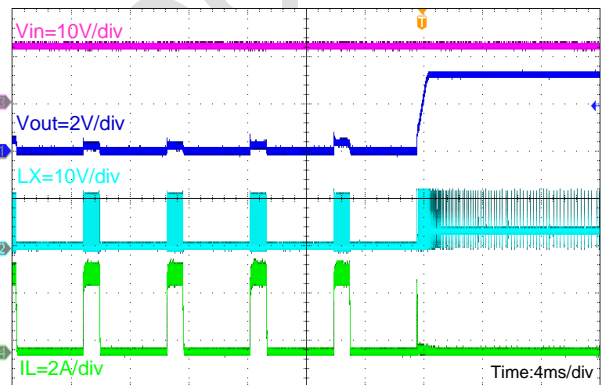

Output Short Entry

$V_{IN} = 12V, V_{OUT} = 3.3V, I_o = 1.2A$

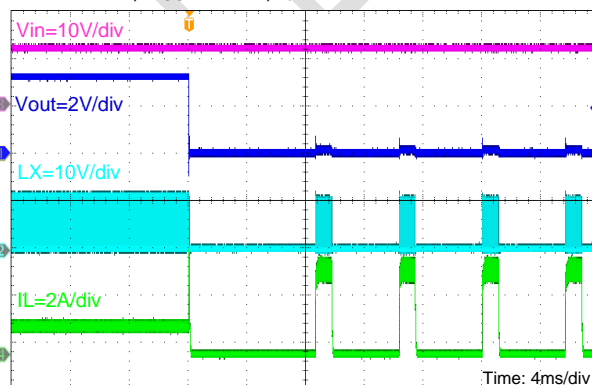

Output Short Recovery

$V_{IN} = 12V, V_{OUT} = 3.3V, I_o = 1.2A$

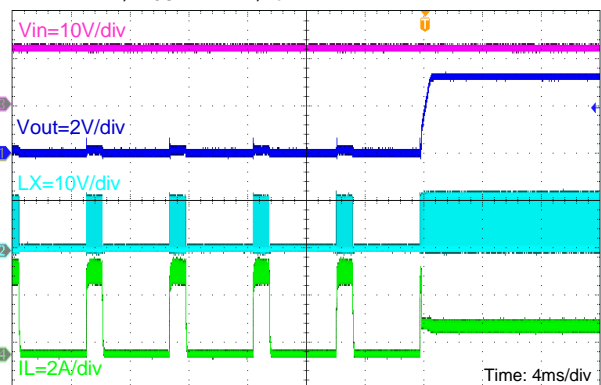

Typical Performance Characteristics (continued)

Input Power On

$V_{IN} = 12V, V_{OUT} = 3.3V, I_o = 1.2A$

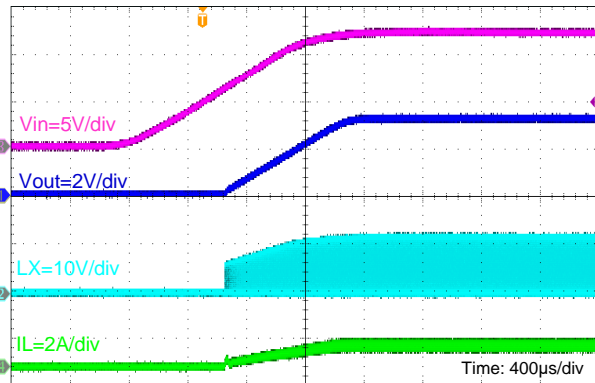

Input Power Down

$V_{IN} = 12V, V_{OUT} = 3.3V, I_o = 1.2A$

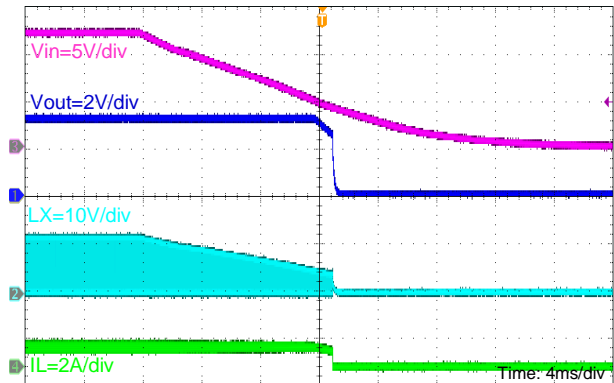

EN Enable

$V_{IN} = 12V, V_{OUT} = 3.3V, \text{No Load}$

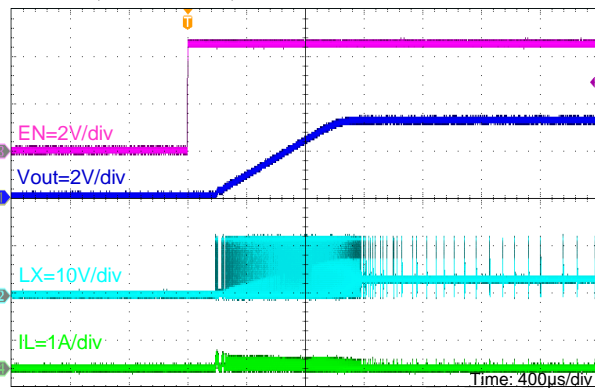

EN Disable

$V_{IN} = 12V, V_{OUT} = 3.3V, \text{No Load}$

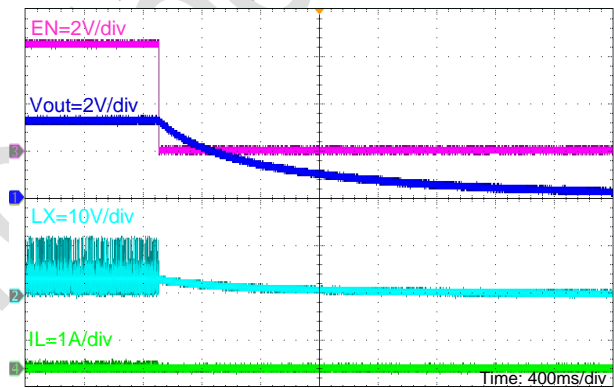

EN Enable

$V_{IN} = 12V, V_{OUT} = 3.3V, I_o = 1.2A$

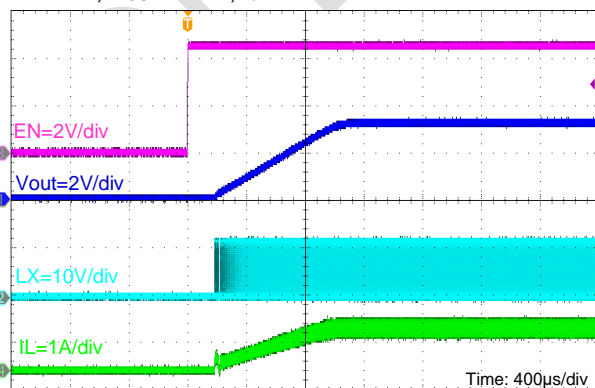

EN Disable

$V_{IN} = 12V, V_{OUT} = 3.3V, I_o = 1.2A$

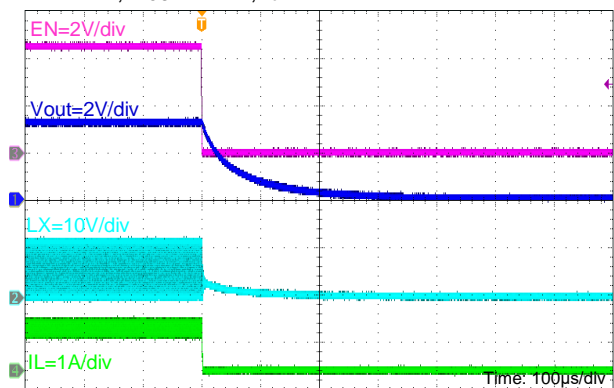

Package Information

SOT23-6

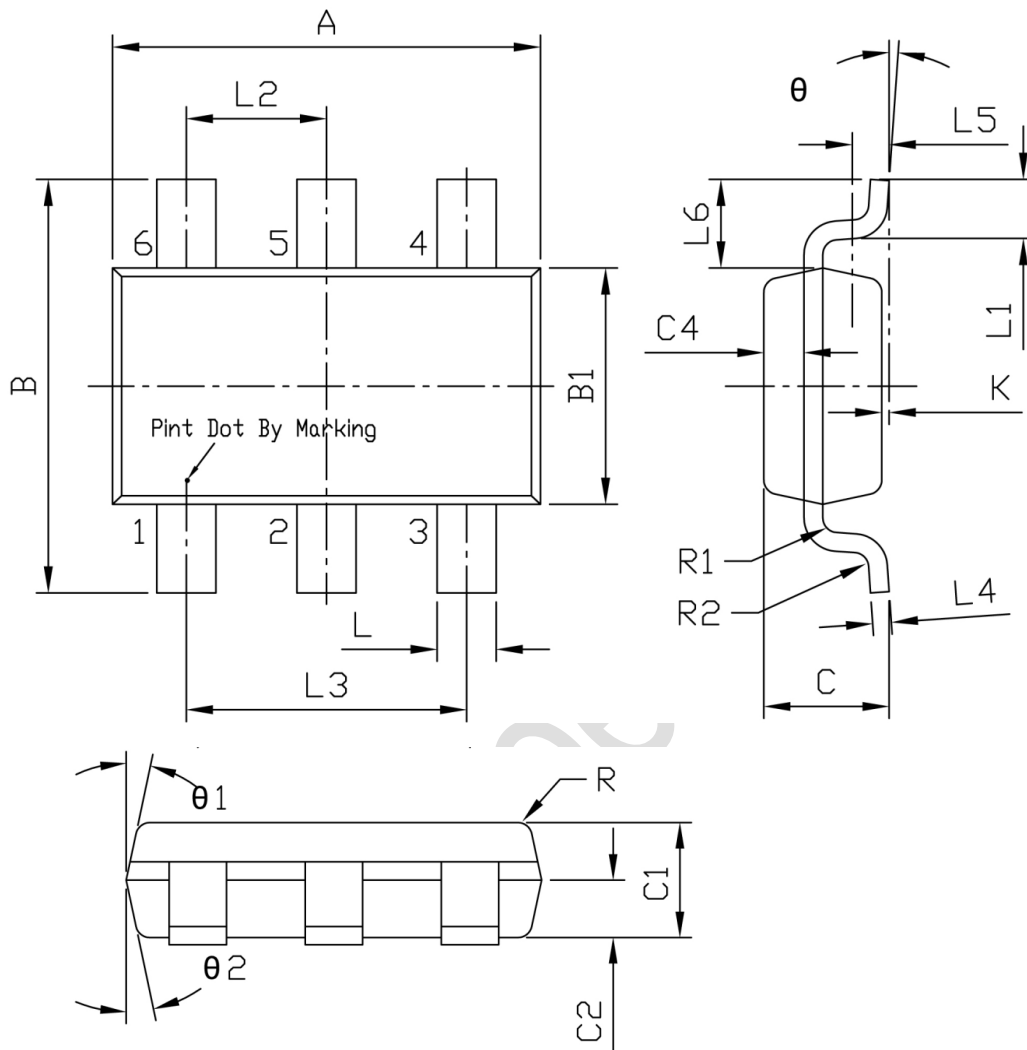

Unit: mm

Symbol	Dimensions In Millimeters			Symbol	Dimensions In Millimeters		
	Min	Typ	Max		Min	Typ	Max
A	2.80	2.90	3.00	L3	1.800	1.900	2.000
B	2.60	2.80	3.00	L4	0.077	0.127	0.177
B1	1.50	1.60	1.70	L5	-	0.250	-
C	-	-	1.05	L6	-	0.600	-
C1	0.60	0.80	1.00	θ	0°		0°
C2	0.35	0.40	0.45	$\theta1$	10°	12°	14°
C4	0.223	0.273	0.323	$\theta2$	10°	12°	14°
K	0.000	0.075	0.150	R	-	0.100	-
L	0.325	0.400	0.475	R1	-	0.100	-
L1	0.325	0.450	0.550	R2	-	0.100	-
L2	0.850	0.950	1.050				

Tape and Reel Information

Tape Dimensions:

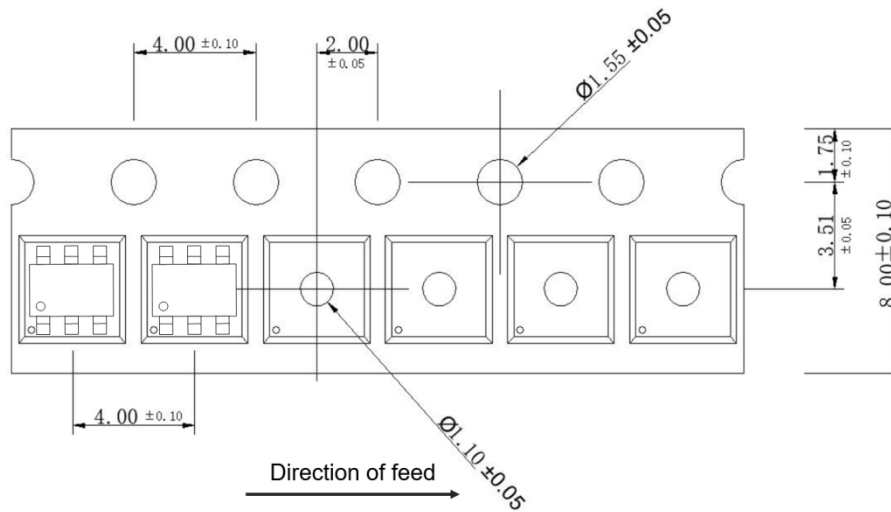

Reel Dimensions:

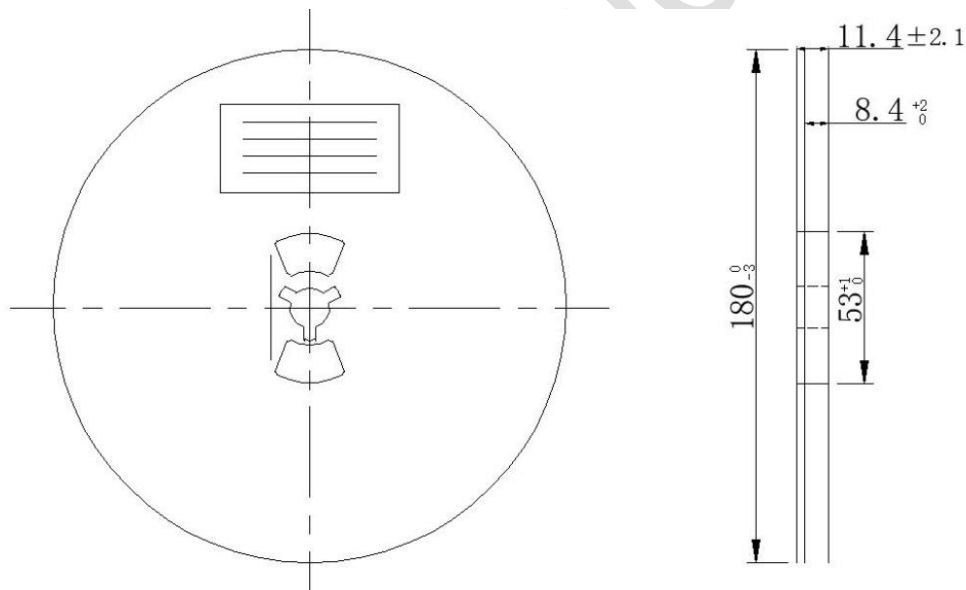

Note:

- 1) All Dimensions are in Millimeter
- 2) Quantity of Units per Reel is 3000
- 3) MSL level is Level 3.