

Click [here](#) for production status of specific part numbers.

## MAX14916

## Compact Industrial Octal 1A/Quad 2A High-Side Switch with Diagnostics

### General Description

The MAX14916 has eight high-side switches specified to deliver up to 1.1A (min) continuous current per channel. The two adjacent channels can be paralleled to form four 2.4A high-side switches. The high-side switches have on-resistance of 250mΩ (max) at 125°C ambient temperature.

The SPI interface has a built-in chip addressing decoder, allowing communication with multiple MAX14916s utilizing a common SPI chip select (CS).

The SPI interface provides flexibility for global and per-channel configuration and diagnostic, including undervoltage detection, open wire/load detection, overload and current limiting reporting, thermal conditions reporting, and more.

Open load detection detects both open-wire/open-load conditions with switches in the on and off states. LED drivers provide indication of per-channel fault, status, and supply undervoltage conditions. Internal active clamps allow for fast turn-off of inductive loads.

Integrated line-to-ground and line-to-line surge protection only requires a TVS on V<sub>DD</sub>. Integrated surge protection works for quad and octal configuration.

The MAX14916 is available in a compact 48-pin 6mm x 6mm QFN package.

### Applications

- Industrial Digital Outputs
- PLC Systems

### Benefits and Features

- Robustness and Smart Diagnostics
  - 65V Absolute Maximum Supply Range
  - Internal Clamps for Fast Inductive Load Demagnetization
  - CRC Error Checking on the SPI Interface
  - Watchdog Timer
  - Open-Wire Detection, Both with Switches On and Off
  - Undervoltage Detection with UVLO
  - Loss of V<sub>DD</sub> or GND Protection
  - Thermal Shutdown Protection
  - Integrated ±1kV/42Ω IEC61000-4-5 Surge Protection
  - -40°C to +125°C Operating Ambient Temperature
- Reduces Power and Heat Dissipation
  - 250mΩ (max) On-Resistance at T<sub>A</sub> = 125°C
  - 2mA (typ) Supply Current
  - Accurate Output Current Limiting
- Flexibility
  - Addressable SPI Interface Reduces Isolation Cost
  - SYNCH Input for Simultaneous Update of Switches
  - LED Driver Matrix for 16 LEDs, Powered by 24V, 5V, or 3.3V
  - Flexible Logic Voltage Interface from 2.5V to 5.5V
- Compact 6mm x 6mm QFN Package

[Ordering Information](#) appears at end of data sheet.

Simplified Block Diagram

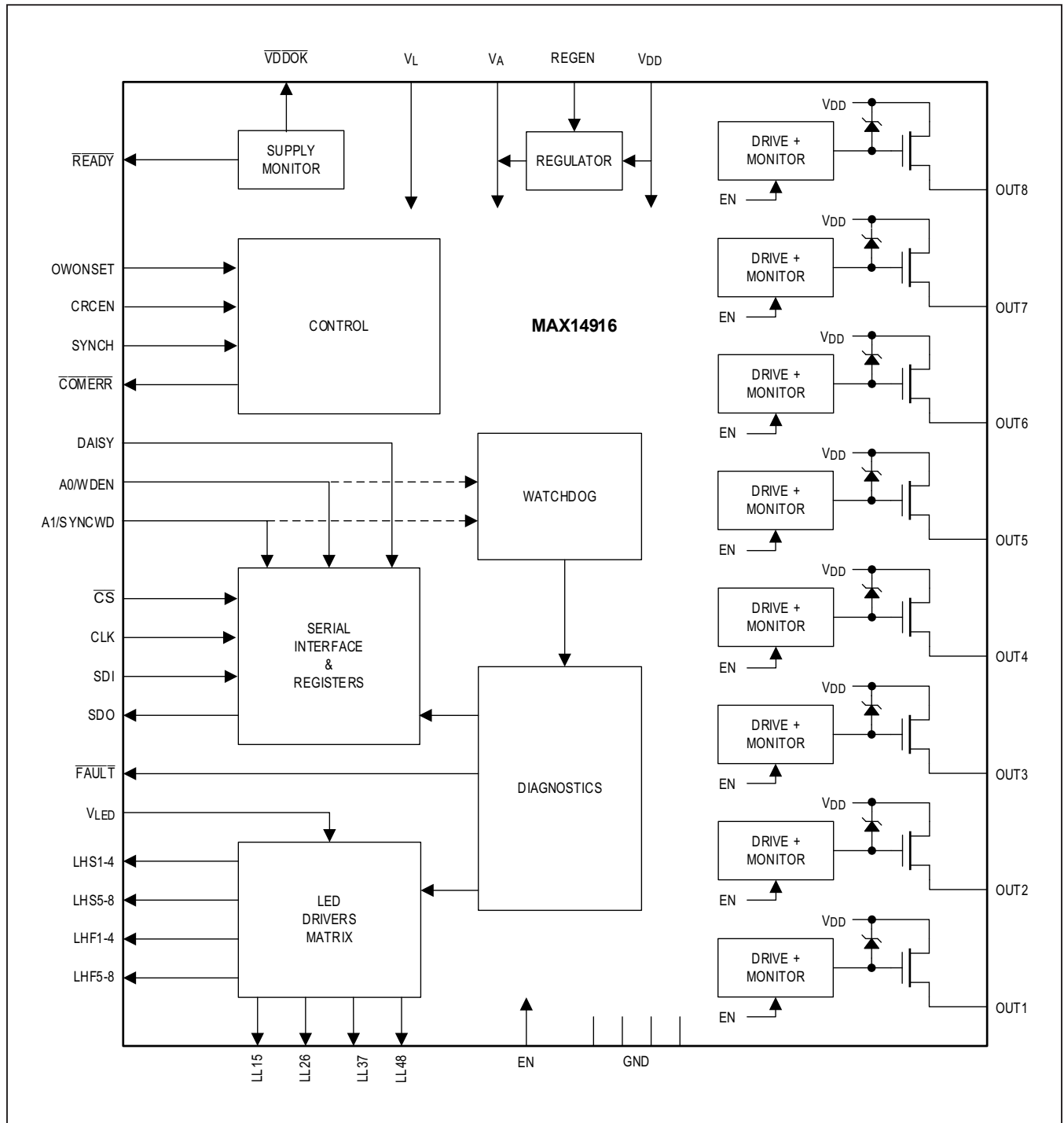

**Absolute Maximum Ratings**

V <sub>DD</sub> .....	-0.3V to +65V	LH_, LL_, $\overline{\text{VDDOK}}$ .....	-0.3V to (V <sub>LED</sub> + 0.3)V
OUT_.....	(V <sub>DD</sub> - 49)V to (V <sub>DD</sub> + 0.3)V	OUT_ Load Current.....	Internally Limited
V <sub>A</sub> , V <sub>L</sub> .....	-0.3V to +6V	Continuous Power Dissipation	
SDO, $\overline{\text{READY}}$ , $\overline{\text{COMERR}}$ .....	-0.3V to (V <sub>L</sub> + 0.3)V	(Multilayer Board) (T <sub>A</sub> = +70°C,	
REGEN, OWONSET.....	-0.3V to +6V	derate 50mW/°C above +70°C).....	3900mW
$\overline{\text{FAULT}}$ .....	-0.3V to 6V	Operating Temperature Range.....	-40°C to +125°C
SDI, $\overline{\text{CS}}$ , CLK, EN, ADD0/WDEN, ADD1, SYNCH, CRCEN,		Junction Temperature.....	+150°C
DAISY.....	-0.3V to 6V	Storage Temperature Range.....	-65°C to +150°C
V <sub>LED</sub> .....	-0.3V to +70V	Soldering Temperature (reflow).....	260°C

**Note 1:** All voltages relative to GND.

*Stresses beyond those listed under "Absolute Maximum Ratings" may cause permanent damage to the device. These are stress ratings only, and functional operation of the device at these or any other conditions beyond those indicated in the operational sections of the specifications is not implied. Exposure to absolute maximum rating conditions for extended periods may affect device reliability.*

**Package Information**

**Flip Chip QFN**

Package Code	F486A6F-1
Outline Number	<a href="#">21-100232</a>
Land Pattern Number	<a href="#">90-100077</a>
<b>Thermal Resistance, Four-Layer Board:</b>	
Junction to Ambient (θ <sub>JA</sub> )	20.5°C/W
Junction to Case (θ <sub>JC</sub> )	0.39°C/W (bottom)

For the latest package outline information and land patterns (footprints), go to [www.maximintegrated.com/packages](http://www.maximintegrated.com/packages). Note that a "+", "#", or "-" in the package code indicates RoHS status only. Package drawings may show a different suffix character, but the drawing pertains to the package regardless of RoHS status.

Package thermal resistances were obtained using the method described in JEDEC specification JESD51-7, using a four-layer board. For detailed information on package thermal considerations, refer to [www.maximintegrated.com/thermal-tutorial](http://www.maximintegrated.com/thermal-tutorial).

## Electrical Characteristics

( $V_{DD} = +10V$  to  $+36V$ ,  $V_{LED} = +3.0V$  to  $36V$ ,  $V_A = +3.0V$  to  $+5.5V$ ,  $V_L = +2.5V$  to  $+5.5V$ ,  $T_A = -40^\circ C$  to  $+125^\circ C$ , unless otherwise noted. Typical values are at  $V_{DD} = V_{LED} = 24V$ ,  $V_A = 3.3V$ ,  $T_A = +25^\circ C$ .) (Note 2)

PARAMETER	SYMBOL	CONDITIONS	MIN	TYP	MAX	UNITS
<b>DC CHARACTERISTICS/SUPPLY</b>						
$V_{DD}$ Supply Voltage	$V_{DD}$		10		36	V
$V_{DD}$ Supply Current	$I_{DD}$	EN = high, OUT_ switches on, no load, $V_A$ and $V_L$ supplied externally		2	3	mA
		EN = low			3	
$V_{DD}$ UVLO Rise Threshold	$V_{DD\_UVLO\_R}$	$V_{DD}$ rising			9.6	V
$V_{DD}$ UVLO Fall Threshold	$V_{DD\_UVLO\_F}$	$V_{DD}$ falling, OUT_ disabled, $V_{DDUVLO}$ bit set	7.9			V
$V_{DD}$ UVLO Hysteresis	$V_{DD\_UVLO\_H}$			0.35		V
$V_{DD}$ Warn Rise Threshold	$V_{DD\_WARN\_R}$	$V_{DD}$ rising			14	V
$V_{DD}$ Warn Fall Threshold	$V_{DD\_WARN\_F}$	$V_{DD}$ falling, $V_{DDWARN}$ bit set, $\overline{V_{DDOK}}$ pin set HiZ	12			V
$V_{DD}$ Warn Hysteresis	$V_{DD\_WARN\_H}$			0.4		V
$V_{DD}$ Good Rise Threshold	$V_{DD\_GOOD\_R}$	$V_{DD}$ rising, $V_{DDNOTGOOD}$ bit set, $\overline{V_{DDOK}}$ pin set HiZ			17	V
$V_{DD}$ Good Fall Threshold	$V_{DD\_GOOD\_F}$	$V_{DD}$ falling	15			V
$V_{DD}$ Good Hysteresis	$V_{DD\_GOOD\_H}$			0.4		V
$V_{DD}$ POR Rise Threshold	$V_{DD\_POR\_R}$	$V_{DD}$ rising			6.8	V
$V_{DD}$ POR Falling Threshold	$V_{DD\_POR\_F}$	$V_{DD}$ falling	5.6			V
$V_A$ Supply Voltage	$V_{VA}$	When $V_A$ is supplied externally; REGEN = GND.	3.0		5.5	V
$V_A$ Supply Current	$I_{VA}$	EN = high, OUT_ are turned on, no load, no LEDs connected		0.5	0.85	mA
$V_A$ Undervoltage Lockout Threshold	$V_{VA\_UV}$	$V_{DD} = 24V$ , $V_A$ falling	2.35		2.8	V
$V_A$ Undervoltage Lockout Hysteresis	$V_{VA\_UVHYST}$	$V_{DD} = 24V$		0.1		V
$V_L$ Supply Voltage	$V_{VL}$		2.5		5.5	V
$V_L$ Supply Current	$I_{VL}$	All logic inputs high or low		13	34	$\mu A$
$V_L$ POR Threshold	$V_{L\_POR}$	$V_L$ falling	0.87	1.32	1.5	V
<b>DC CHARACTERISTICS/SWITCH OUTPUTS (OUT_)</b>						
On-Resistance	$R_{OUT\_HS}$	$I_{OUT\_} = -600mA$		120	250	m $\Omega$
Current Limit	$I_{LIM}$	Octal configuration	1.10	1.38	1.67	A
		Quad configuration	2.40	2.78	3.20	
Off Leakage Current	$I_{LKG}$	OL detect = off, switch off, $OUT\_ = 0V$	-10		10	$\mu A$

## Electrical Characteristics (continued)

( $V_{DD} = +10V$  to  $+36V$ ,  $V_{LED} = +3.0V$  to  $36V$ ,  $V_A = +3.0V$  to  $+5.5V$ ,  $V_L = +2.5V$  to  $+5.5V$ ,  $T_A = -40^\circ C$  to  $+125^\circ C$ , unless otherwise noted. Typical values are at  $V_{DD} = V_{LED} = 24V$ ,  $V_A = 3.3V$ ,  $T_A = +25^\circ C$ .) (Note 2)

PARAMETER	SYMBOL	CONDITIONS	MIN	TYP	MAX	UNITS
<b>DC CHARACTERISTICS/LINEAR REGULATOR</b>						
Output Voltage	$V_{VA}$	REGEN open, $C_{load} = 1\mu F$ , $0mA < I_{VA} < 20mA$	3.0	3.3	3.6	V
Current Limit	$I_{CL\_VA}$	REGEN open	25			mA
Short Current	$I_{SHRT\_VA}$	REGEN open, $V_A = 0V$			60	mA
Load Regulation		$0mA < I_{VA} < 20mA$		0.1		mV/mA
REGEN Threshold	$V_{TREGEN}$		0.2			V
REGEN Leakage Current	$I_{LK\_REGEN}$	REGEN = 0V	-50			$\mu A$
<b>DC CHARACTERISTICS/OFF STATE DIAGNOSTICS (OUT_)</b>						
Pullup Current, OWOFF	$I_{PU\_OWOFF1}$	$OWOff\_ = 1$ , $V_{OUT\_} < 5V$ , $OWOffCs1 = 0$ , $OWOffCs0 = 0$	10	20	32	$\mu A$
	$I_{PU\_OWOFF2}$	$OWOff\_ = 1$ , $V_{OUT\_} < 5V$ , $OWOffCs1 = 0$ , $OWOffCs0 = 1$	65	100	135	
	$I_{PU\_OWOFF3}$	$OWOff\_ = 1$ , $V_{OUT\_} < 5V$ , $OWOffCs1 = 1$ , $OWOffCs0 = 0$	230	300	370	
	$I_{PU\_OWOFF4}$	$OWOff\_ = 1$ , $V_{OUT\_} < 5V$ , $OWOffCs1 = 1$ , $OWOffCs0 = 1$	480	600	720	
OUT_ Voltage, OWOFF	$V_{OUT\_OFF}$	$OWOff\_ = 1$ , $I_{OUT\_} = 0mA$	5.7	6.7	7.8	V
Open Wire Detect Threshold, OWOFF	$V_{TH\_OWOFF}$	$OWOff\_ = 1$	5		5.8	V
Short to $V_{DD}$ Detect Threshold	$V_{TH\_SHVDD}$	$ShVddEn\_ = 1$ , $ShrtVddThr1 = 0$ , $ShrtVddThr0 = 0$	8.2	9.0	10.0	V
		$ShVddEn\_ = 1$ , $ShrtVddThr1 = 0$ , $ShrtVddThr0 = 1$	9.1	10	10.9	
		$ShVddEn\_ = 1$ , $ShrtVddThr1 = 1$ , $ShrtVddThr0 = 0$	11	12	13	
		$ShVddEn\_ = 1$ , $ShrtVddThr1 = 1$ , $ShrtVddThr0 = 1$	13	14	15	
<b>DC CHARACTERISTICS/ON STATE DIAGNOSTICS</b>						
Open Wire Detect Threshold Current, On	$I_{TH\_OWON}$	$OWOn\_ = 1$ , $ROWONSET = 500k\Omega$	0.05	0.13	0.2	mA
		$OWOn\_ = 1$ , $ROWONSET = 160k\Omega$	0.25	0.35	0.55	
		$OWOn\_ = 1$ , $ROWONSET = 30k\Omega$	1.8	2.4	2.9	
<b>DC CHARACTERISTICS/LOGIC I/O</b>						
Input Voltage High	$V_{IH}$		$0.7 \times V_L$			V
Input Voltage Low	$V_{IL}$				$0.3 \times V_L$	V
Input Threshold Hysteresis	$V_{IHYS}$			$0.11 \times V_L$		V
Input Pulldown Resistor	$R_{IN\_PD}$	See logic pin descriptions for applicable pins		200		k $\Omega$
Input Pullup Resistor	$R_{IN\_PU}$	See logic pin descriptions for applicable pins		200		k $\Omega$
Output Logic-High (SDO)	$V_{OH}$	$I_{LOAD} = -5mA$	$V_L - 0.6$			V

**Electrical Characteristics (continued)**

( $V_{DD} = +10V$  to  $+36V$ ,  $V_{LED} = +3.0V$  to  $36V$ ,  $V_A = +3.0V$  to  $+5.5V$ ,  $V_L = +2.5V$  to  $+5.5V$ ,  $T_A = -40^\circ C$  to  $+125^\circ C$ , unless otherwise noted. Typical values are at  $V_{DD} = V_{LED} = 24V$ ,  $V_A = 3.3V$ ,  $T_A = +25^\circ C$ .) (Note 2)

PARAMETER	SYMBOL	CONDITIONS	MIN	TYP	MAX	UNITS
Output Logic-Low	$V_{OL}$	$I_{LOAD} = +5mA$			0.33	V
SDO Output Tristate Leakage	$I_{L\_SDO}$	$\overline{CS} = \text{high}$	-1		+1	$\mu A$
<b>DC CHARACTERISTICS/OPEN-DRAIN OUTPUT (<math>\overline{FAULT}</math>, <math>\overline{COMERR}</math>, <math>\overline{READY}</math>)</b>						
READY Output Logic-High	$V_{ODH}$	$I_{LOAD} = -5mA$	$V_L - 0.6$			V
Output Logic-Low	$V_{ODL}$	$I_{LOAD} = +5mA$			0.33	V
Leakage	$I_{ODL}$	Open-drain output off, $V = 5.5V$	-1		+1	$\mu A$
<b>DC CHARACTERISTICS/LED Drivers (<math>LH\_</math>, <math>LL\_</math>, <math>\overline{VDDOK}</math>)</b>						
LED Supply Voltage	$V_{LED}$		3.0		$V_{DD}$	V
LH Voltage High	$V_{OH\_LH}$	$LH = \text{on}$ , $I_{LEDH} = -5mA$	$V_{LED} - 0.3$			V
LH Off Leakage Current	$I_{L\_LH}$	$LH\_ = \text{off}$ , $V_{LEDH} = 0V$	-1		+1	$\mu A$
LL Output Voltage Low	$V_{OH\_LL}$	$LL = \text{on}$ , $I_{LDL} = 5mA$			0.3	V
LL Off Leakage Current	$I_{L\_LL}$	$LL = \text{off}$ , $V_{LL} = V_{LED}$	-1		+1	$\mu A$
<b>DC CHARACTERISTICS/PROTECTION</b>						
OUT_ Clamp Voltage	$V_{CL}$	$V_{CL} = V_{DD} - OUT$ , $I_{OUT\_} = -500mA$ , $OUT\_$ is off	49	56		V
Channel Thermal Shutdown Temperature	$T_{JSHDN}$	Junction temperature rising. Per channel.		150		$^\circ C$
Channel Thermal Shutdown Hysteresis	$T_{JSHDN\_HYST}$			15		$^\circ C$
Chip Thermal Shutdown	$T_{CSHDN}$	Temperature rising.		150		$^\circ C$
Chip Thermal Shutdown Hysteresis	$T_{CSHDN\_HYST}$			10		$^\circ C$
<b>TIMING CHARACTERISTICS/OUT_</b>						
Prop Delay LH	$t_{PD\_LH}$	Delay from rising SYNCH edge to $OUT\_$ rising to 90%. $R_L = 48\Omega$ , $V_{DD} = 24V$ , <a href="#">Figure 2</a>		11	30	$\mu s$
Prop Delay HL	$t_{PD\_HL}$	Delay from rising SYNCH edge to $OUT\_$ falling to 10% of $V_{DD}$ , $V_{DD} = 24V$ , $R_L = 48\Omega$ , <a href="#">Figure 2</a>		11	30	$\mu s$
Rise-Time	$t_R$	20% to 80% $V_{DD}$ , $V_{DD} = 24V$ , $R_L = 48\Omega$ , <a href="#">Figure 2</a>		8		$\mu s$
Fall-Time	$t_F$	80% to 20% $V_{DD}$ , $V_{DD} = 24V$ , $R_L = 48\Omega$ , <a href="#">Figure 2</a>		8		$\mu s$

**Electrical Characteristics (continued)**

( $V_{DD} = +10V$  to  $+36V$ ,  $V_{LED} = +3.0V$  to  $36V$ ,  $V_A = +3.0V$  to  $+5.5V$ ,  $V_L = +2.5V$  to  $+5.5V$ ,  $T_A = -40^\circ C$  to  $+125^\circ C$ , unless otherwise noted. Typical values are at  $V_{DD} = V_{LED} = 24V$ ,  $V_A = 3.3V$ ,  $T_A = +25^\circ C$ .) (Note 2)

PARAMETER	SYMBOL	CONDITIONS	MIN	TYP	MAX	UNITS
<b>TIMING CHARACTERISTICS/WATCHDOG</b>						
Watchdog Timeout	$t_{WD}$	WDT0[1:0] = 01b		200		ms
		WDT0[1:0] = 10b		600		
		WDT0[1:0] = 11b		1200		
Watchdogs Timeout Accuracy	$t_{WD\_ACC}$	WDEN = 1, SynchWDEn = 1, see Config2 register for watchdog timeout	-30		+30	%
<b>TIMING CHARACTERISTICS/LED Matrix</b>						
LED Driver Scan rate	FLED	Update rate for each LED		1		kHz
<b>TIMING CHARACTERISTICS/SPI</b> <a href="#">Figure 1</a>						
CLK Clock Period	$t_{CH+CL}$		100			ns
CLK Pulse Width High	$t_{CH}$		40			ns
CLK Pulse Width Low	$t_{CL}$		40			ns
$\overline{CS}$ Fall to CLK Rise Time	$t_{CSS}$		40			ns
SDI Hold Time	$t_{DH}$		10			ns
SDI Setup Time	$t_{DS}$		10			ns
SDO Propagation Delay	$t_{DO}$	Clload = 10pF, CLK falling edge to SDO stable			30	ns
SDO Rise and Fall Times	$t_{FT}$			1		ns
$\overline{CS}$ Hold Time	$t_{CSH}$		40			ns
$\overline{CS}$ Pulse Width High	$t_{CSPW}$	Note 3	40			ns
<b>EMC</b>						
ESD IEC Contact Discharge	$V_{ESD\_C}$	OUT_ to GND, IEC61000-4-2		$\pm 7$		kV
ESD IEC Air Discharge	$V_{ESD\_A}$	OUT_ to GND, IEC61000-4-2		$\pm 30$		kV
ESD	$V_{ESD}$	All other pins. Human Body Model (Note 4)		$\pm 2$		kV
Surge Tolerance	$V_{SURGE}$	OUT_ to GND, IEC61000-4-5 with 42 $\Omega$ , TVS on $V_{DD}$ . (Note 5)		$\pm 1$		kV

**Note 2:** All units are production tested at  $T_A = +25^\circ C$ . Specifications over temperature are guaranteed by design.

**Note 3:** All logic input pins except  $\overline{CS}$  have a pulldown resistor.  $\overline{CS}$  has a pullup resistor.

**Note 4:** Bypass  $V_{DD}$  pin to GND with 1 $\mu F$  capacitor as close as possible to the device for high ESD protection.

**Note 5:** At typical application value of  $V_{DD} = 24V$ , with a TVS protection on  $V_{DD}$  to GND.

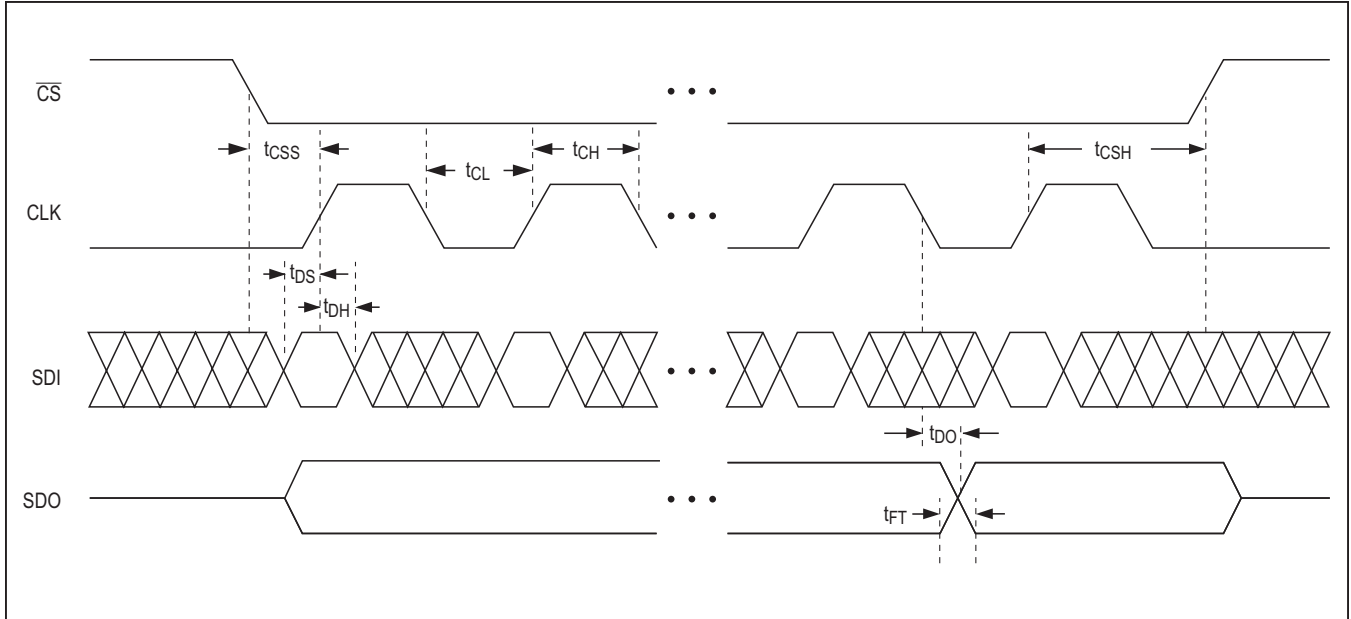

Figure 1. SPI Timing Diagram.

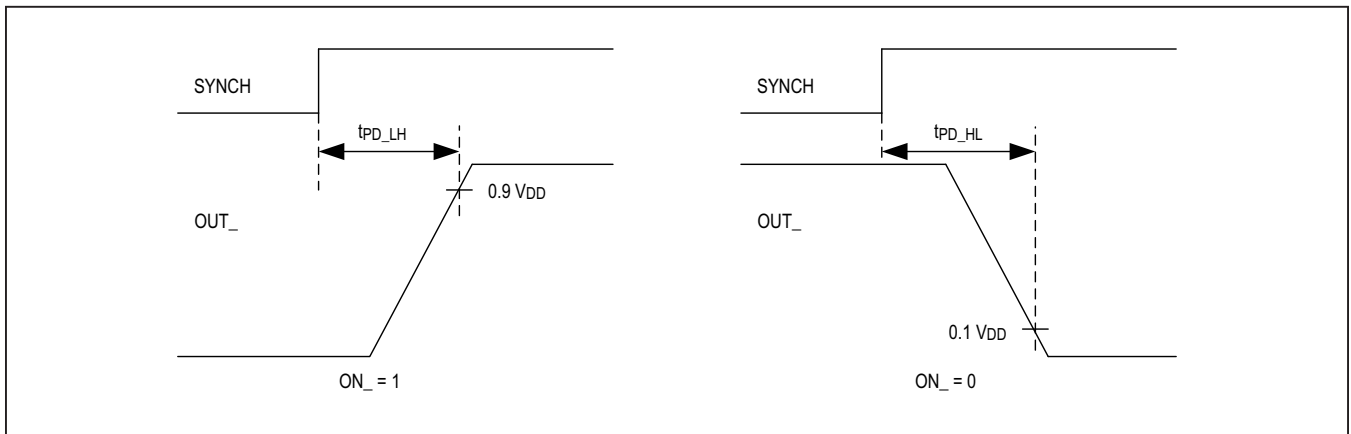
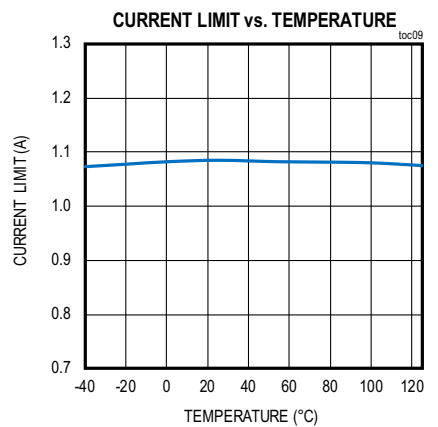
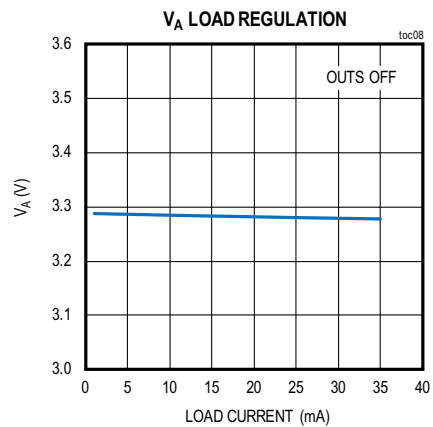
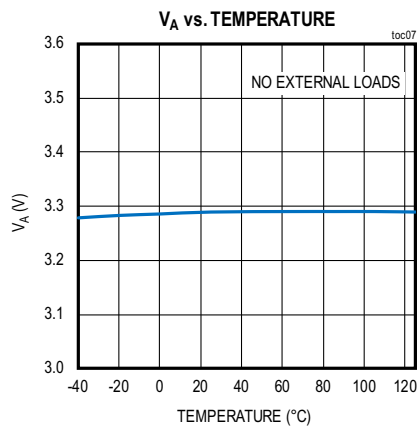
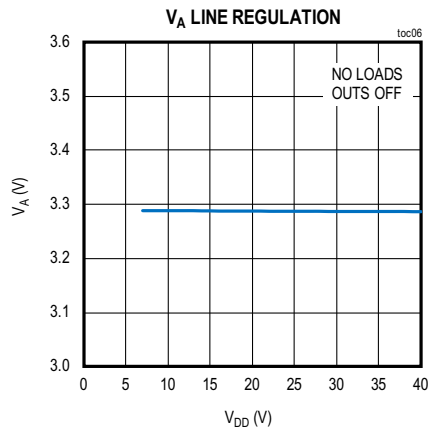
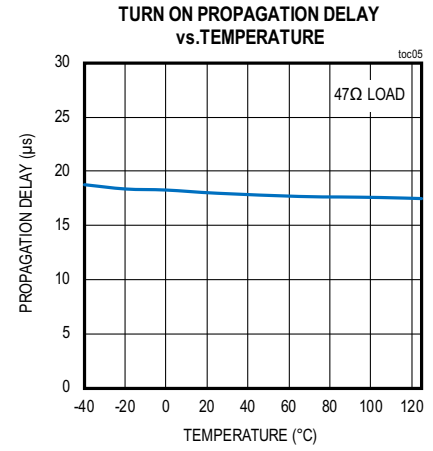
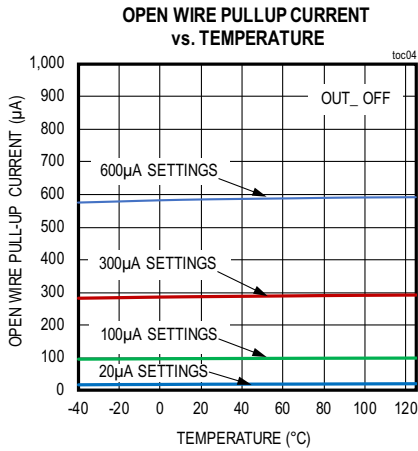
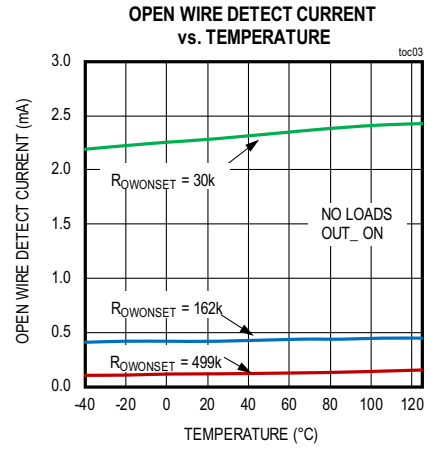
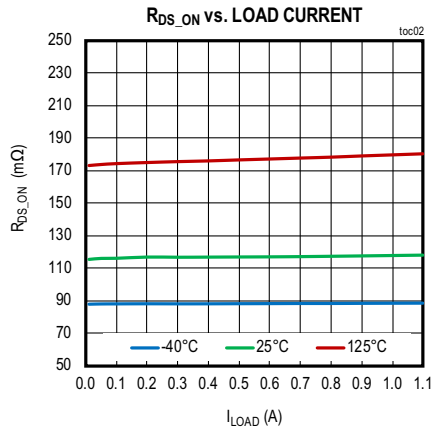
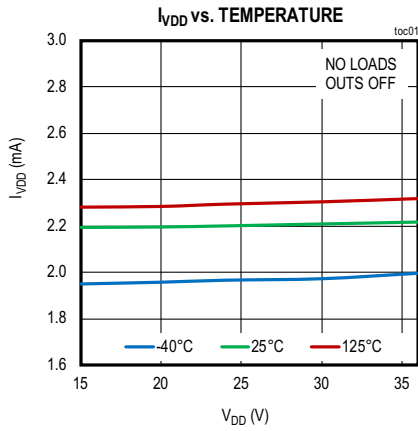

Figure 2. Propagation Delay Timing Characteristics



Typical Operating Characteristics

( $V_{DD} = +24V$ , REGEN = open,  $V_L = +3.3V$ ,  $T_A = +25^\circ C$ , unless otherwise noted)



Pin Configuration

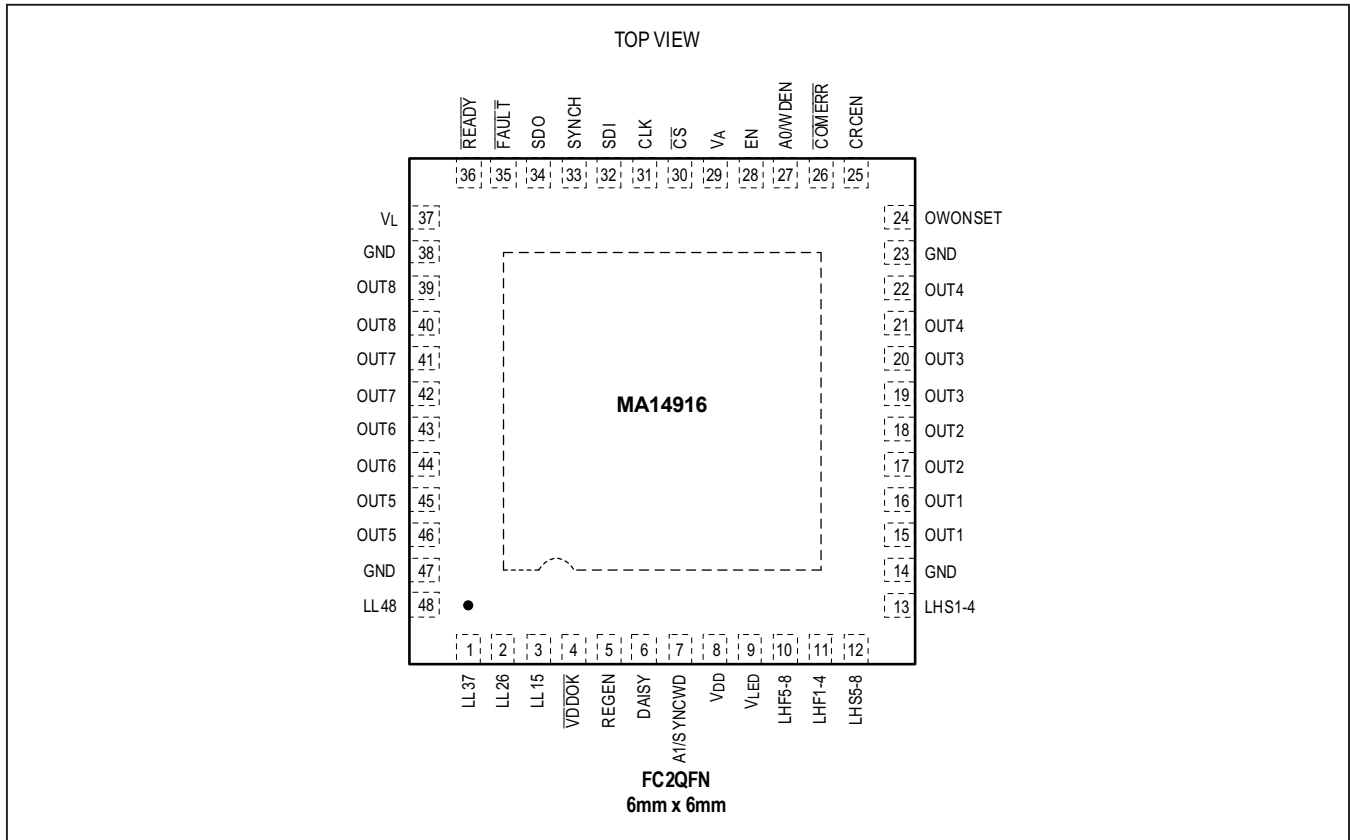

Pin Description

PIN	NAME	FUNCTION	REF SUPPLY	TYPE
<b>POWER SUPPLY</b>				
EP, 8	V <sub>DD</sub>	Supply Voltage, Nominally 24V. Connect all V <sub>DD</sub> together. Bypass V <sub>DD</sub> to GND through a 1µF capacitor.	GND	Supply
29	V <sub>A</sub>	Analog Supply Input. Connect an external 3.0V to 5.5V supply to V <sub>A</sub> or use the internal linear regulator by leaving REGEN open. Bypass V <sub>A</sub> to GND through a 1µF ceramic capacitor.	GND	Supply
5	REGEN	V <sub>A</sub> Regulator Enable Input. Connect REGEN to GND to disable V <sub>A</sub> regulator. Leave REGEN open to enable V <sub>A</sub> regulator, which internally supplies V <sub>A</sub> with 3.3V.	GND	Supply
14, 23, 38, 47	GND	Ground. Connect all GND pins together.	GND	GND
37	V <sub>L</sub>	Logic Supply Input. V <sub>L</sub> defines the logic levels on all logic interface pins. Bypass V <sub>L</sub> to GND through a 100nF ceramic capacitor.	GND	Supply
4	V <sub>DDOK</sub>	V <sub>DDOK</sub> is an active-low, open-drain logic output that indicates when the V <sub>DD</sub> supply is OK. V <sub>DDOK</sub> turns on low when V <sub>DD</sub> rises to > 16V(typ) and turns off when V <sub>DD</sub> falls to < 13V (typ). Connect a LED with a pullup resistor to a voltage between 3.3V and V <sub>DD</sub> .	GND	Logic

## Pin Description (continued)

PIN	NAME	FUNCTION	REF SUPPLY	TYPE
<b>SWITCH OUTPUTS</b>				
15, 16	OUT1	High-Side Switch Output 1	V <sub>DD</sub>	Power
17, 18	OUT2	High-Side Switch Output 2	V <sub>DD</sub>	Power
19, 20	OUT3	High-Side Switch Output 3	V <sub>DD</sub>	Power
21, 22	OUT4	High-Side Switch Output 4	V <sub>DD</sub>	Power
45, 46	OUT5	High-Side Switch Output 5	V <sub>DD</sub>	Power
43, 44	OUT6	High-Side Switch Output 6	V <sub>DD</sub>	Power
41, 42	OUT7	High-Side Switch Output 7	V <sub>DD</sub>	Power
39, 40	OUT8	High-Side Switch Output 8	V <sub>DD</sub>	Power
<b>DIAGNOSTIC SETTING</b>				
24	OWON-SET	Open-Wire Detection Threshold Current Set. Connect a resistor between OWONSET and GND to define the threshold current for open-wire detection when the OUT_ switches are closed.	V <sub>A</sub>	Analog
<b>CONTROL INTERFACE</b>				
28	EN	Enable Logic Input. Drive EN high for normal operation. Drive EN low to disable/three-state all OUT_ drivers. Internal weak pulldown.	V <sub>L</sub>	Logic
35	$\overline{\text{FAULT}}$	$\overline{\text{FAULT}}$ Global Diagnostics Open-Drain Output. The $\overline{\text{FAULT}}$ transistor turns on low under conditions defined in the Interrupt register. Connect a pullup resistor to V <sub>L</sub> .	V <sub>L</sub>	Logic
33	SYNCH	SYNCH Input. All eight output switches are updated simultaneously on the rising edge of SYNCH, as determined by the contents of the SPI register. The OUT_ states do not change when SYNCH is held low. When SYNCH is high, the output states change immediately when a new value is written into the SetOUT register. Internal weak pullup.	V <sub>L</sub>	Logic
25	CRCEN	CRC Enable Select Input. Drive CRCEN high to enable CRC generation and error detection on the serial data. CRC has a weak pulldown.	V <sub>L</sub>	Logic
36	$\overline{\text{READY}}$	$\overline{\text{READY}}$ is an open-drain output that is passive low when the internal logic chip supply and V <sub>L</sub> I/O supply are both higher than their respective UVLO thresholds, indicating that the part is ready for SPI communication. When the internal register supply falls below the UVLO threshold the register contents are lost and $\overline{\text{READY}}$ transitions active-high. Connect a pulldown resistor to $\overline{\text{READY}}$ .	V <sub>L</sub>	Logic
26	$\overline{\text{COMERR}}$	$\overline{\text{COMERR}}$ SPI Error Open-Drain Output. The $\overline{\text{COMERR}}$ transistor turns on low when an error occurs during a SPI transaction. Connect a pullup resistor to V <sub>L</sub> .	V <sub>L</sub>	Logic

## Pin Description (continued)

PIN	NAME	FUNCTION	REF SUPPLY	TYPE
<b>SERIAL INTERFACE</b>				
32	SDI	Serial Data Input. SPI MOSI data from controller. SDI has a weak pulldown.	$V_L$	Logic
34	SDO	Serial Data Output. SPI MISO data output to controller.	$V_L$	Logic
31	CLK	Serial Clock Input from SPI Controller. CLK has a weak pulldown.	$V_L$	Logic
30	$\overline{CS}$	Chip Select Input from Controller. $\overline{CS}$ has a weak pullup.	$V_L$	Logic
27	A0/WDEN	Chip address LSB for addressable SPI or SPI watchdog enable input for daisy-chain SPI. AO/WDEN has a weak pulldown.	$V_L$	Logic
7	A1/SYN-CWD	Chip Address MSB for Addressable SPI. SYNCH pin watchdog enable input for daisy-chain SPI. A1/SYNCWD has a weak pulldown.	$V_L$	Logic
6	DAISY	Daisy-Chain Enable Select Input. Drive DAISY high to enable daisy-chained SPI mode. DAISY has a weak pulldown.	$V_L$	Logic
<b>LED DRIVER MATRIX</b>				
9	$V_{LED}$	Supply for LED Drivers. Apply supply voltage of 3.0V to $V_{DD}$ .		
3	LL15	OUTs 1, 5 Status/Fault LED Cathode Output (Open-Drain Low-Side). Connect a resistor in series to set the LED current.		
2	LL26	OUTs 2, 6 Status/Fault LED Cathode Output (Open-Drain Low-Side). Connect a resistor in series to set the LED current.		
1	LL37	OUTs 3, 7 Status/Fault LED Cathode Output (Open-Drain Low-Side). Connect a resistor in series to set the LED current.		
48	LL48	OUTs 4, 8 Status/Fault LED Cathode Output (Open-Drain Low-Side). Connect a resistor in series to set the LED current.		
13	LHS1-4	OUTs 1-4 Status LED Anode Outputs (Open-Drain High-Side). Connect a resistor in series to set the LED current.		
12	LHS5-8	OUTs 5-8 Status LED Anode Outputs (Open-Drain High-Side). Connect a resistor in series to set the LED current.		
11	LHF1-4	OUTs 1-4 Fault LED Anode Connections (Open-Drain High-Side). Connect a resistor in series to set the LED current.		
10	LHF5-8	OUTs 5-8 Fault LED Anode Connections (Open-Drain High-Side). Connect a resistor in series to set the LED current.		

## Detailed Description

The MAX14916 is an octal high-side switch. The OUT\_ high-side switches have 250mΩ (max) on-resistance  $T_A = 125^{\circ}\text{C}$ . Extensive diagnostics can be enabled through SPI to indicate wire-break, overload, current limiting, output short to  $V_{DD}$ , low supply voltage, and high chip temperature conditions. Active clamping limits the negative OUT\_ voltage to  $(V_{DD} - V_{CL})$  and allows for freewheeling currents to demagnetize the inductive loads quickly. A watchdog timer monitors SPI activity and automatically turns the OUT\_ switches off in case of missing SPI activity.

### Synchronization

On the rising edge of the SYNCH logic input, all OUT\_ switches change to the new state previously programmed into the SetOUT register. If SYNCH is held high, then the OUT\_ change state immediately when the SetOUT register is written to (transparent mode).

When EN pin is low, all OUT\_ are off independent of the SYNCH pin state and the SetOUT register value.

### Power-Up and Undervoltage Lockout

When the  $V_{DD}$ ,  $V_A$ ,  $V_L$ , or  $V_{INT}$  supply voltages are under their respective UVLO thresholds, all OUT\_ switches are off and the open wire detect current sources are turned off.  $V_{INT}$  is an internal supply for the registers and logic that is derived from the  $V_A$  or  $V_{DD}$  supply.

When the  $V_{DD}$  supply or  $V_A$  supply rises, the internal logic supply,  $V_{INT}$ , rises. If  $V_L$  and  $V_{INT}$  are both above their UVLO thresholds, the chip is ready for communication and the  $\overline{\text{READY}}$  pin becomes passive low to indicate that the part is ready to communicate through the SPI interface.

In addressed SPI mode (DAISY pin is low) the  $V_{DD}UVLO$ ,  $V_{DD}NotGood$ ,  $V_{DD}Warn$ ,  $V_{INT\_UV}$ , and  $V_A\_UVLO$  bits are set = 1 and the  $\overline{\text{FAULT}}$  output is set active-low. These bits and the  $\overline{\text{FAULT}}$  pin only clear once the GlobalErr register is read.

The register contents are lost when both  $V_A$  and  $V_{DD}$  drop low and the internal register supply,  $V_{INT}$ , falls below its undervoltage lockout threshold.

The  $V_{INT\_UV}$  bit = 1 signals that the register contents are in power-on-reset state and any custom configuration can be programmed or needs to be reprogrammed after a power reset event.

When  $V_{DD}$  rises above  $V_{DD\_UVLO\_R}$  (with  $V_{DD}OnTh = 0$ ) or above  $V_{DD\_GOOD\_R}$  (with  $V_{DD}OnThr = 1$ ) the  $\overline{\text{VDDOK}}$  pin is turned active-low, indicating that the

$V_{DD}$  supply is high enough so the OUT\_ switches can be operated normally.

When  $V_{DD}$  falls below  $V_{DD\_WARN\_F}$  (~13V), the  $V_{DD}Warn$  bit (if  $V_{DD}OKM = 0$ ) and, thus,  $\overline{\text{FAULT}}$  are set but the OUT\_ switches continue operating normally.

When  $V_{DD}$  falls further below  $V_{DD\_UVLO\_F}$ , the  $V_{DD\_UVLO}$  bit is set and the OUT\_ switches are turned off.

In daisy-chain mode (DAISY pin high), the  $\overline{\text{READY}}$  and  $\overline{\text{VDDOK}}$  pins are active, but the  $\overline{\text{FAULT}}$  pin does not signal supply conditions.

### Chip Thermal Protection

When the chip temperature rises to above the thermal shutdown threshold of  $150^{\circ}\text{C}$ , the chip enters shutdown protection and all overloaded OUT switches are kept off until chip temperature drops below  $140^{\circ}\text{C}$ . The  $\text{ThrmShut}$  bit and  $\overline{\text{FAULT}}$  output are set.

If the chip temperature rises above  $165^{\circ}\text{C}$  due to a short, an overload on the  $V_A$  regulator, or LED matrix, the internal  $V_A$  linear regulator, all OUT switches, and the LED matrix are shutdown to prevent part damage. In this condition, the  $\text{ThrmShut}$  bit and  $\overline{\text{FAULT}}$  output are already set and in daisy-chain mode the F-bits in SDO are all set to 1. The register contents are not lost in thermal shutdown if  $V_{DD}$  supply is present.

When the chip temperature then falls by the hysteresis amount, the  $V_A$  regulator turns on, LED matrix and OUT switches are restored to normal operation.

### Channel Thermal Management

Every driver's temperature is constantly monitored. If the temperature of a driver rises above the thermal shutdown threshold of  $150^{\circ}\text{C}$  (typ), that channel is automatically turned off for protection. After the temperature drops by  $15^{\circ}\text{C}$ , the driver will be turned on again.

When a driver turns off due to thermal shutdown, the per-channel overload bits,  $\text{OVL}_$ , the interrupt  $\text{OverLdFault}$  bit and  $\overline{\text{FAULT}}$  pin indicate this condition, if enabled. See [Register Map](#).

### Current Limiting

Each high-side switch features active current limiting. When the load current exceeds 1.1A (min), the load current is limited by the high-side switch. The current limit is increased to 2.4A (min) if two channels are paralleled. If the load impedance tries to draw higher current, the voltage across the high-side FET switch increases and the temperature of the FET increases in accordance with the FET's power dissipation. When an OUT\_ channel shows an overcurrent, the  $\text{CL}_$  bit is set in the  $\text{CurrLimF}$  register.

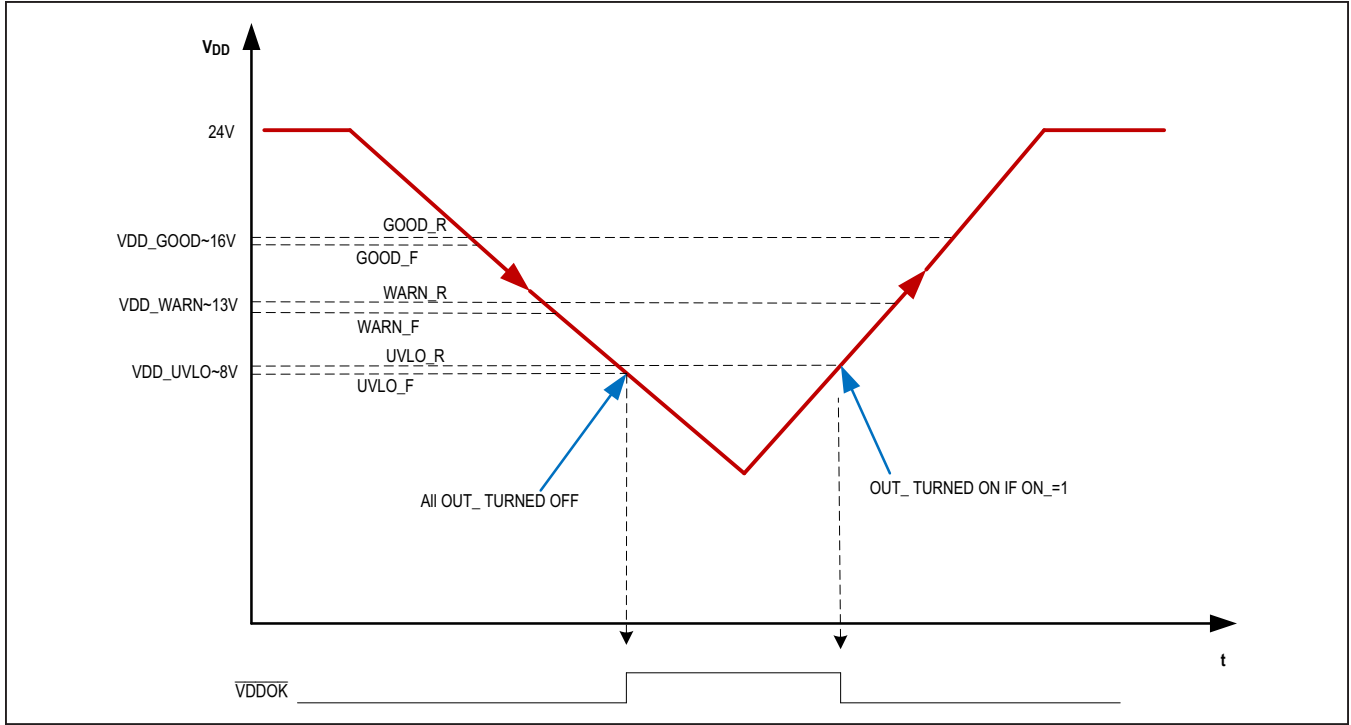

Figure 3. V<sub>DD</sub> Monitoring with VDDOnThr = 0

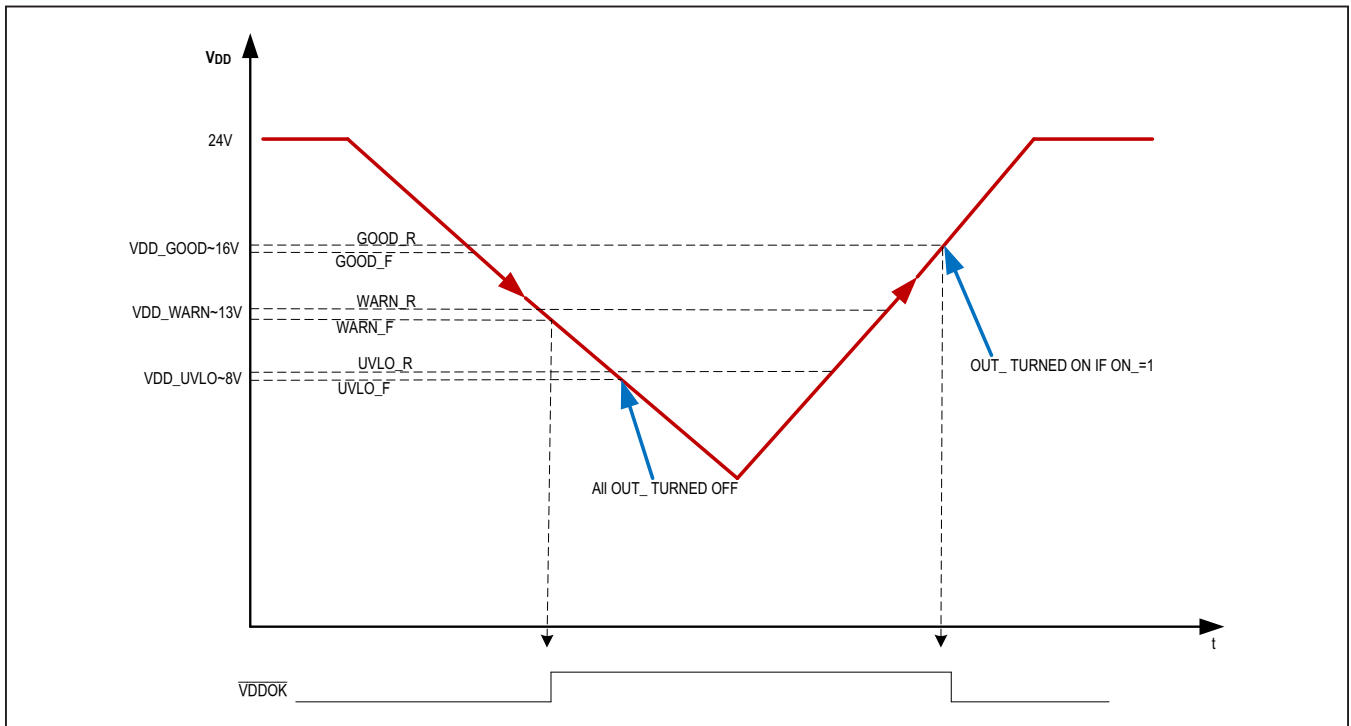

Figure 4. V<sub>DD</sub> Monitoring with VDDOnThr = 1

## Lamp Load Turn On

Incandescent lamps initially draw high currents while their filament is cold, and this turn-on current reduces as the filament heats up. The MAX14916 has a scheme that automatically detects the presence of a lamps loads. When a lamp load is detected the overtemperature and overload messages are avoided for a duration of 200ms. The lamp load detection is transparent to the user and is not signaled to the user.

## Diagnostics

[Table 2](#) lists the per channel diagnostics made available by the MAX14916. The state of the high-side switch for which diagnostics are determined is shown in the [Table 1](#).

[Table 2](#) summarizes the global diagnostics.

## Diagnostics Filtering

Open-wire detection and short-to- $V_{DD}$  detection, in conjunction with reactive loads, can take many milliseconds to settle to stable conditions after a change of high-side switch state. During this time, diagnostic

detection would not generate reliable results. Therefore, after the  $OUT\_$  switching instant, a blanking period of 4ms (optionally 8ms through register bit) is observed, during which these diagnostics are not evaluated. After this 4ms blanking time, an averaging filter is engaged for 4ms, after which the short-to- $V_{DD}$  and open-wire diagnostics are determined and updated as per channel diagnostics in the  $OwOffChF$ ,  $OwOnChF$ , and  $ShtVDDChF$  registers, and consequentially, the Interrupt register, FLEDs (if  $FLEDSet = 0$ ), and diagnostic bits in the SDO data (if read).

When an  $OUT\_$  switch changes On/Off state, the diagnostic state for the previous state is cleared internally. The registers diagnostic bits are cleared if  $FLatchEn = 0$ . If  $FLatchEn = 1$ , the diagnostic bits become clear on read and are cleared by an SPI read command.

For the overload and overcurrent diagnostics detection, a 54 $\mu$ s filter time is employed and there is no blanking time. If a lamp load is detected on an  $OUT\_$ , this is seen as a normal load and, therefore, overload and overcurrent diagnostics are not set during the lamp-load detect time.

**Table 1. Per-Channel Diagnostics**

PER CHANNEL DIAGNOSTIC	SWITCH STATE	ENABLED	INTERRUPT MASK ENABLED
Overload	Closed	by default	by OverIdM
Overcurrent	Closed	by default	by CurrLimM
Open Wire On	Closed	per channel	by OWOnM
Open Wire Off	Open	per channel	by OWOffM
Short to VDD	Open	per channel	by ShtVddM

**Table 2. Global Diagnostics**

GLOBAL DIAGNOSTICS	FUNCTION	ENABLED	FAULT INTERRUPT MASK
ThrmShut	Chip thermal shutdown	Always On	None
Vint_UV	Undervoltage on the internal supply for the SPI registers	Always On	None
VA_UVLO	VA was in undervoltage	Always On	SupplyErrM
VDD_Warn	Low VDD warning	Always On	VddOKM
VddUvlo	VDD supply in UVLO, all $OUT\_$ switches turned off	Always On	SupplyErrM
VddNotGood	Not Good VDD warning	Always On	VddOKM
WDErr	SPI has no activity for the timeout period	by $WDTo[1:0]$ (DAISY = Low) by $A0/WDEN$ (DAISY = High)	ComErrM
SynchErr	SYNCH input stuck low for the timeout period	by $SynchWDEn$ (DAISY = Low) by $A1/SWDEN$ (DAISY = High)	ComErrM
ComErr	SPI CRC or Communication error	by CRCEN pin	ComErrM



**Open-Wire Detection**

Monitoring of an open wire/open load condition can be enabled on a per-channel basis through serial configuration. Open-wire detection can be selected for either, or both, of the cases with a high-side switch in the on or/and the off state.

**Open-Wire Detection with Switch On**

Open load detection can be enabled on any OUT\_ switch through the OwOnEN\_ bits. When the HS switch is on, the load current flowing out of the high-side switch is monitored. If this current drops to below a threshold value set through the resistor connected to the OWONSET, an open load detection fault is reported.

The OWONSET resistor allows selecting a load current threshold in the range of 0.35mA (typ) to 2.5mA (typ)

When two channels are paralleled for achieving higher total load, the open-wire ON diagnostics need closer consideration. The open-load ON detection should be enabled on all paralleled channels. If open-load is not signaled on any of the paralleled channels, then an open load condition does not exist. Similarly, if open-load is signaled on all paralleled channels, then an open-load condition does exist.

For the intermediate case where one channel signals an open-load while the other does not, an open-load condition might exist, but due to the level of channel-to-channel mismatching, also might not exist. In this case, if an accurate open-load measurement is required, based on the current threshold set by the OWONSET resistor, the following procedure should be used:

- 1) Turn-off the high-side switch of the channel that shows an open-load on condition.

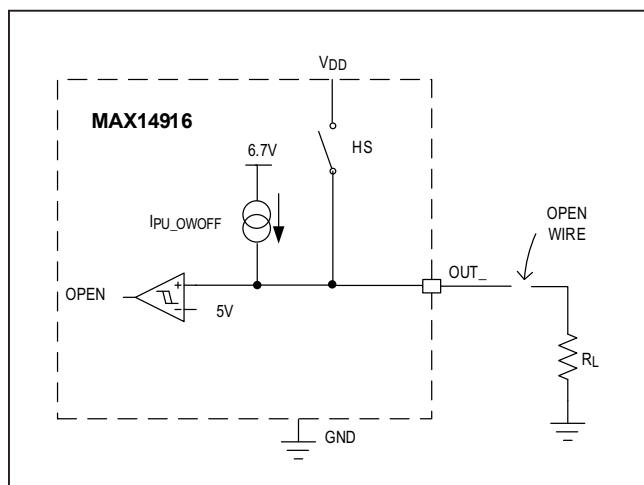

Figure 5. Open Wire Detection Scheme

- 2) Then recheck the OpenWireOn diagnostic on the complementary channel, whose open-load on diagnostic was off. This provides an accurate open-load on condition.

For open-wire On LED indication, the fault LED should be controlled by the microcontroller, not autonomously by the MAX14916.

**Open-Wire Detection with Switch Off**

Monitoring of an open-wire condition in the switch off-state can be enabled on individual channels through the OWOffEn\_ bits. When the HS switch is off, a weak current source, IPU\_OWOFF, is enabled that pulls OUT\_ up to 6.7V during a wire break. If the OUT\_ voltage is above 5V(min) and below the V<sub>TH\_SHVDD</sub> open load is signaled.

For two paralleled channels, enable open wire detection only on one of the channels so that the pullup current is kept low. Add a 500kΩ resistor from OUT\_ to GND to pull down OUT\_ to approximately 6.7V or if unconnected above approximately 6.7V.

**Short to V<sub>DD</sub> Detection**

The MAX14916 can detect shorts to V<sub>DD</sub>, if enabled through SPI. This only detects when an OUT\_ switch is off. If the OUT\_ voltage is higher than the threshold voltage set by the ShrtVddThr0 and ShrtVddThr1 bits, a ShtVddFault is indicated in the GloblErr and ShtVddChF registers, as well as the FAULT output pin (if not masked). The bits allow setting a V<sub>TH\_SHVDD</sub> threshold in the range of 9V to 14V when V<sub>DD</sub> is above VDD\_GOOD threshold. For V<sub>DD</sub> below 16V (typ), the V<sub>TH\_SHVDD</sub> is always set to 9V independently by the ShtVddChF bits.

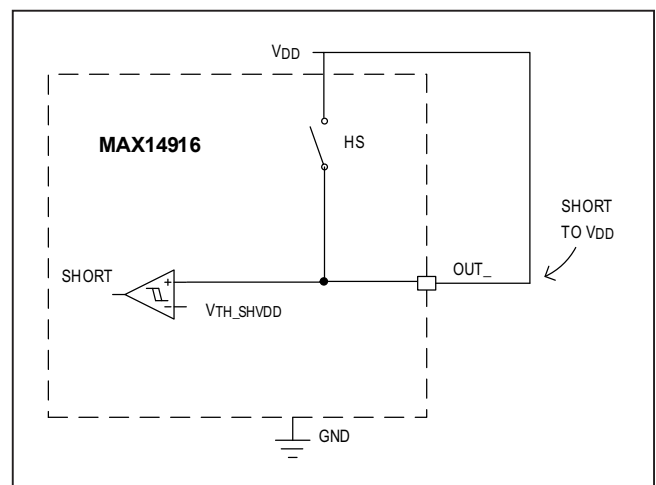

Figure 6. Short to V<sub>DD</sub> Detection Scheme



**Diagnostic Bit Behavior**

The per channel diagnostic bits (OVL\_, CL\_, OWOFF\_, OWON\_, SHVDD\_) can be configured to be latched (clear on read) or real-time through the FLatchEn bit in the Config1 register. When latched diagnostics are enabled (FLatchEn = 1), the diagnostic bits are set = 1 when a fault is detected and remains = 1, even if the fault disappears. This bit is only reset to = 0 when the cause of the fault has disappeared AND the relevant fault register is read through SPI — in address SPI mode. If the cause of the fault has not disappeared, the diagnostic bit remains = 1.

In daisy-chain mode, the  $\overline{\text{FAULT}}$  pin and the F-bits in SDO are cleared on the following SPI cycle if the fault condition was removed.

The per-channel faults in each of the five error registers are logically or'ed together to produce the fault bits in the Interrupt register. This is shown in the following diagram on the basis of overload diagnostics.

**$\overline{\text{FAULT}}$  Pin Signalling**

The  $\overline{\text{FAULT}}$  pin is an open-drain logic output that transitions active low when a fault condition is detected. The source of faults are the eight bits in the Interrupt register: per-channel faults and global faults. The source of  $\overline{\text{FAULT}}$  can be masked through the Mask register.

In addressed SPI mode, the diagnostics can be latched (FLatchEn = 1), in which case the  $\overline{\text{FAULT}}$  pin can only be cleared by reading the Interrupt register AND the corresponding fault register(s), whose fault is latched in the Interrupt register. In latched diagnostics mode,  $\overline{\text{FAULT}}$  cannot be cleared by only reading the Interrupt register. If FLatch = 0, then the diagnostic bits, the Interrupt register bits and the  $\overline{\text{FAULT}}$  pin are not latched, so are real time.

In daisy-chain mode, the  $\overline{\text{FAULT}}$  pin is latched, so is cleared on the next SPI cycle, if the cause of the fault has disappeared.

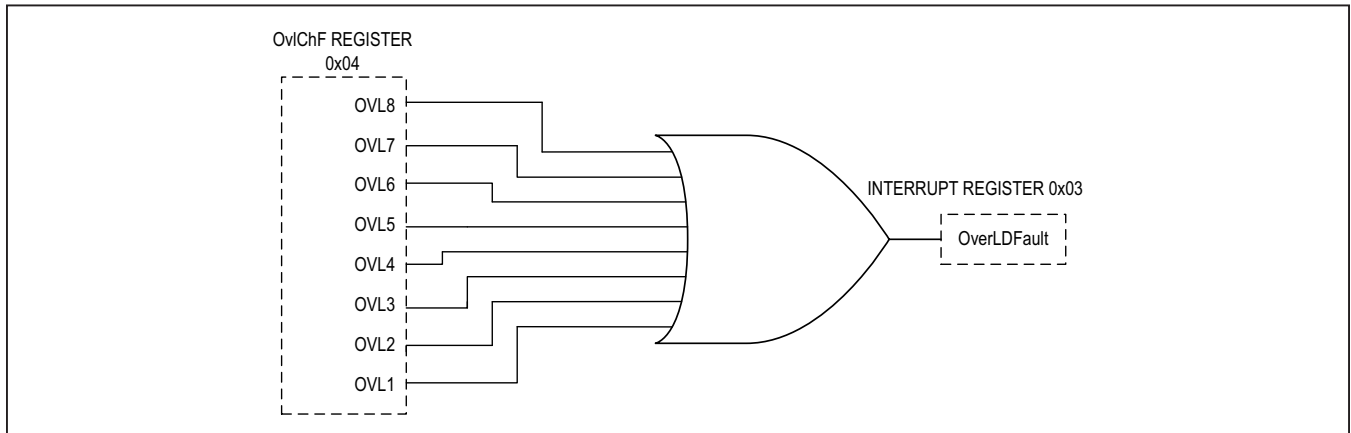

Figure 7. Overload Interrupt Diagnostic Scheme

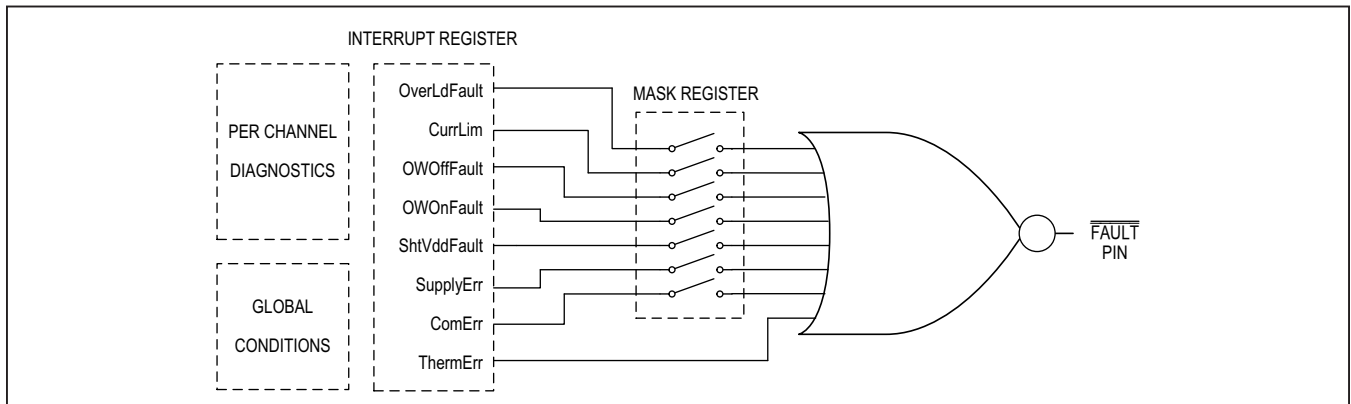

Figure 8.  $\overline{\text{FAULT}}$  Signaling Scheme

**Watchdog**

MAX14916 provides two watchdog timers to allow monitoring activity on the SPI interface and on SYNCH pin. In daisy-chain SPI mode, drive A0/WDEN and/or A1/SYNCH high to enable the watchdog for SPI and/or SYNCH pin. In addressed SPI mode, the watchdog timer is enabled through the WDT0\_bits. If enabled, it will monitor and expect clock activity on the CLK and  $\overline{CS}$  inputs. At least one valid SPI cycle must be detected in the WD-timeout period. This means that the CLK input must have a multiple of 8 clock cycles during a  $\overline{CS}$  low period.

The SYNCH pin watchdog can be enabled by SynchWDEN bit and it will monitor the SYNCH pin if it is not stuck low. At least a 1 $\mu$ s SYNCH pin high must be detected in the WD-timeout period to avoid SYNCH pin watchdog error.

If the watchdog criterion is not met, all OUT\_ switches are automatically turned off and the  $\overline{FAULT}$  pin is set active-low. In addressed SPI mode, the WDErr and ComErr bits are set to 1.

In addresses SPI mode, SYNCH and SPI watchdog timeout can be selected through the WDT0\_bits in the Config2 register. In daisy-chain SPI mode, the watchdog timeout for both SPI and SYNCH pin is 1.2s.

**LED Drivers**

The 4x4 LED driver crossbar matrix offers an efficient configuration for driving up to 16 LEDs. The LEDs can either be turned on/off by the SPI master by setting the SetSLED and/or SetFLED register bits in addressed SPI mode, or can be controlled by the MAX14916 autonomously to indicate per-channel status and fault conditions, depending on configuration in the Config1 register. The number of LEDs can be reduced when the MAX14916 is configured as a quad 2A high-side switch. In such configuration, only one status and one Fault LED per two paralleled channels is required as shown in Figure 9a. In this configuration Outputs 1–2, 3–4, 5–6, and 7–8 are connected together as well as low sides of matrix switches, pins LL15–LL26 and LL37–LL48.

If controlled internally (SLEDSet = 0 or FLEDSet = 0), a channel's status LED will automatically be turned on when the corresponding OUT\_ switch is on and there is no fault condition. If diagnostics detection is enabled on any OUT\_ switch and a fault is detected, its associated fault LED (FLED) is turned on and its associated status LED (SLED) is automatically turned off. This means that for any OUT\_ channel, its SLED and its FLED will never be on simultaneously.

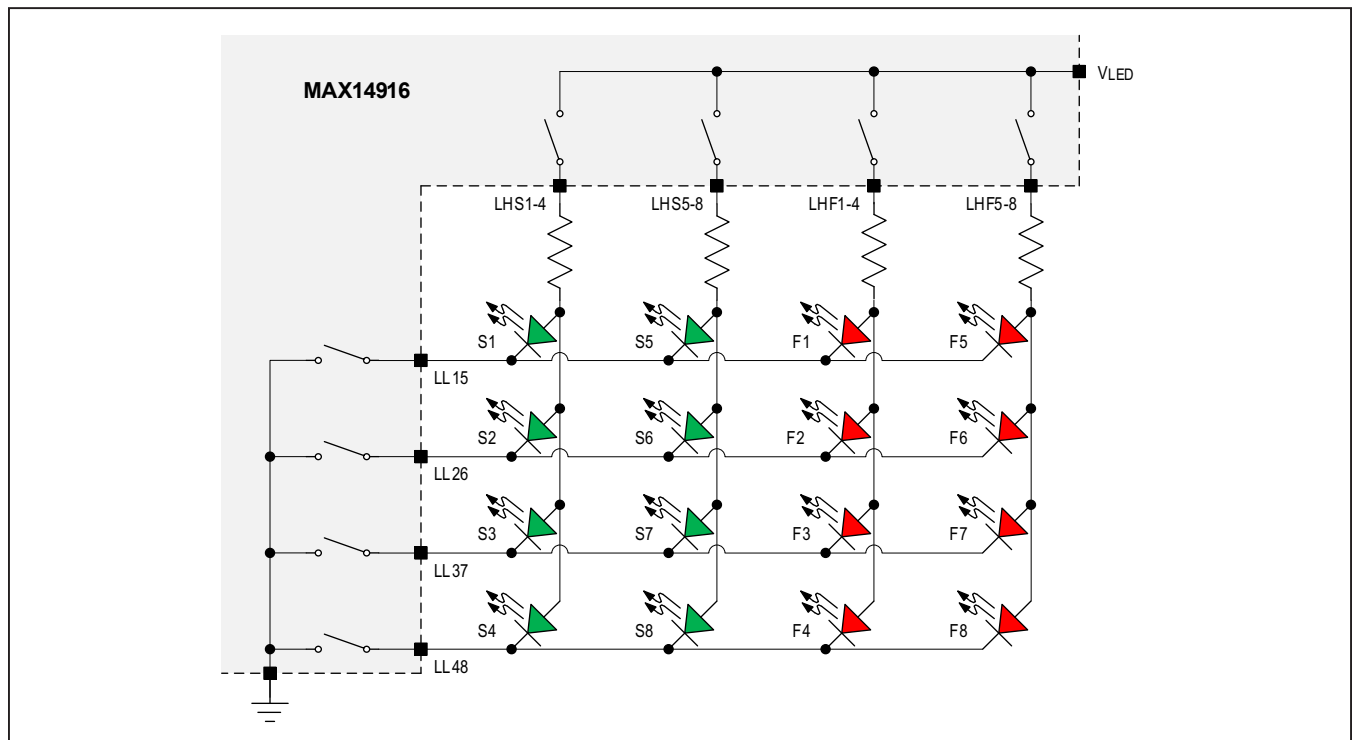

Figure 9. LED Matrix Scheme

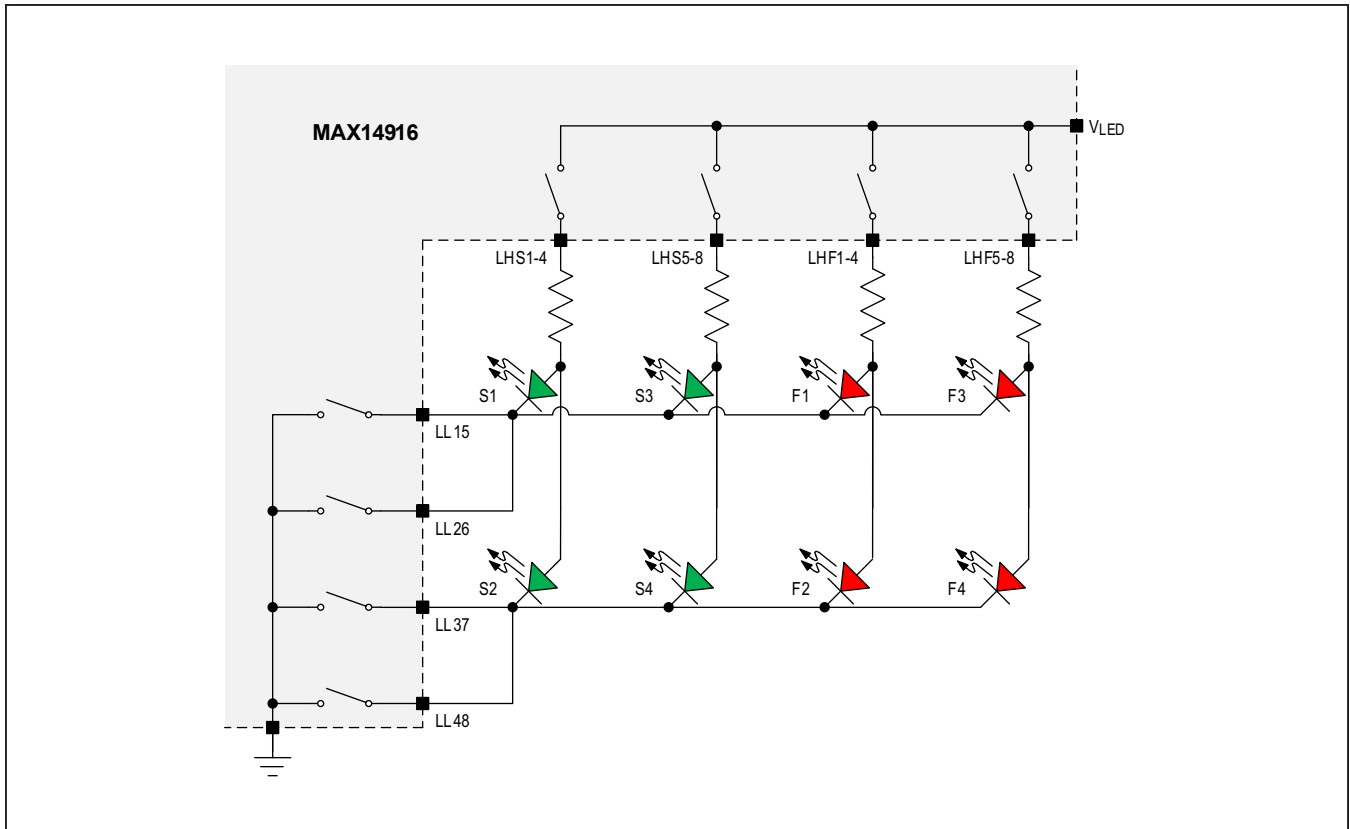

Figure 9a. LED Matrix Scheme for Quad Configuration

If FLEDSet = 0, diagnostics that are enabled (ShtVdd, OWOnCh, OWOff, CL, OVL) will result in FLEDs turning on when a fault is detected. Only overcurrent detection can be masked from driving the FLEDs through the LEDCurrLim bit.

When a lamp load is detected during OUT\_ turn-on, its SLED is turned on and its FLED stays off.

If the FLEDs are controlled internally, they are always filtered, both in daisy chain and addressed SPI modes. When controlled internally, the FLED minimum on-time can be programmed through the two FLEDStretch\_ bits. The SLEDs are real-time when controlled internally.

The LED matrix is powered through the VLED supply input, which can be in the range of the 3.0V (min) up to the VDD field supply voltage.

If daisy-chain mode is selected (DAISY pin high) the LED matrix is always controlled by MAX14916. FAULT LEDs signal only OVL faults and they are stretched by 2s.

For every current limiting resistor, R, each of the four LEDs in a column string is pulsed for a quarter of the time, so that current only flows through one LED and resistor at any one time. Thus the resistors, R, determine the LED current through one LED during the pulse. Each LED is pulsed on at a rate of 1kHz (typ) and is on for 25% of the 1ms period. Thus the average current flowing through a LED that is turned on, is about  $0.25 \times (V_{LED} - V_F)/R$ .  $V_F$  is the forward voltage of the LED. The resistor value should be chosen according to the LED's current/light intensity requirements.

For quad configuration, the current through each LED is doubled and the LED current limiting resistors should be calculated using the equation  $I_{LED} = 0.5 \times (V_{LED} - V_F)/R$ .

### Serial Interface

The MAX14916 communicates with the host controller through a high-speed SPI serial interface. The interface has three logic inputs: clock (CLK), chip select ( $\overline{CS}$ ), serial data in (SDI), and one data out (SDO). The SDO is three-stated when  $\overline{CS}$  is high. The maximum SPI clock rate is 10MHz. The SPI interface logic complies with SPI clock polarity CPOL = 0 and clock phase CPHA = 0.

The MAX14916 SPI can either be operated in addressed SPI mode or in daisy-chain mode. Addressed SPI (DAISY = low) allows direct communication with up to four MAX14916 on a shared SPI using a single, shared  $\overline{CS}$  signal. Addressed SPI offers the advantage direct chip access and getting global diagnostics in the same SPI cycle. Addressed SPI supports both single cycle and burst mode read/writing.

Daisy chained SPI is enabled by driving DAISY = high. In daisy-chain mode, the first SDO byte provides the channel diagnostics based only on driver overload. Daisy-chain mode provides limited features like reduced diagnostics and configuration.

Since the power-on default configuration is different in daisy-chain mode versus addressed SPI modes, the MAX14916 does not support dynamic switching between daisy-chain and addressed SPI modes during operation.

### Addressed SPI Chip Addressing (A1, A0)

In addressed SPI mode, a SPI master can communicate with up to four MAX14916 devices on a shared, non-daisy-chained SPI bus with one single/shared  $\overline{CS}$  through chip addressing. Each chip on the shared SPI is assigned an individual chip address through the logic input pins A1 and A0, see [Table 3](#).

The SPI master addresses a specific chip by sending the appropriate A1, A0 logic in the first and second bits of the SPI read/write command. The MAX14916 monitors the SPI-address in each SPI read/write cycle and responds appropriately when the address matches the programmed address for that IC.

### Addressed SPI In-Band Diagnostic Fault Signaling

In every addressed SPI cycle, the MAX14916 returns six bits in SDO within the first eight SPI CLK cycles. These six bits include the global short-to- $V_{DD}$ , wire-break-on, wire-break-off, overload, overcurrent as well as a global diagnostics bit. The global fault bit, GlobIF, is the logic OR of the ComErr, SupplyErr and ThErr bits. These five diagnostic bits allows for fast identification of the specific channel in fault or global fault condition.

During an SPI write cycle, the second SDO byte returns eight fault bits, one bit associated with each OUT channel. These bits are the logic OR of the diagnostic faults.

**Table 3. SPI Device Address Selection**

A1	A0	DEVICE ADDRESS
LOW	LOW	00
LOW	HIGH	01
HIGH	LOW	10
HIGH	HIGH	11

**Single-Cycle Addressed SPI Read**

Figure 10 shows the SPI read command in addressed SPI mode (DAISY = low).

**Single-Cycle Addressed SPI Write**

Figure 11 shows the SPI write command in SPI addressed mode (DAISY = low):

The F<sub>n</sub> bits in the second byte of SDO write cycle are the per-channel fault bits. These are the logic OR of the channel fault bits in the OvIchF, CurrLimChF, OwOffChF, OwOnChF and ShtVDDChF registers. If only one OUT channel has diagnostic fault(s), then an SPI Write command provides full diagnostic information: the channel and the all faults. The only reason to subsequently read the diagnostic registers is to reset the diagnostic bits.

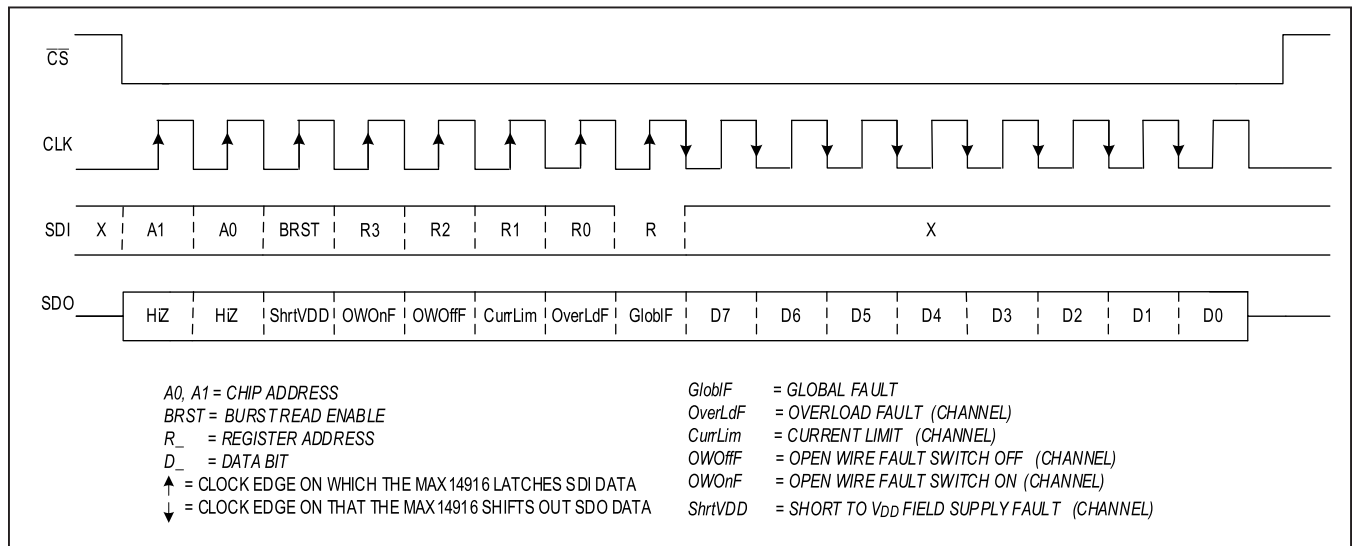

Figure 10. Addressed SPI Single Read Command

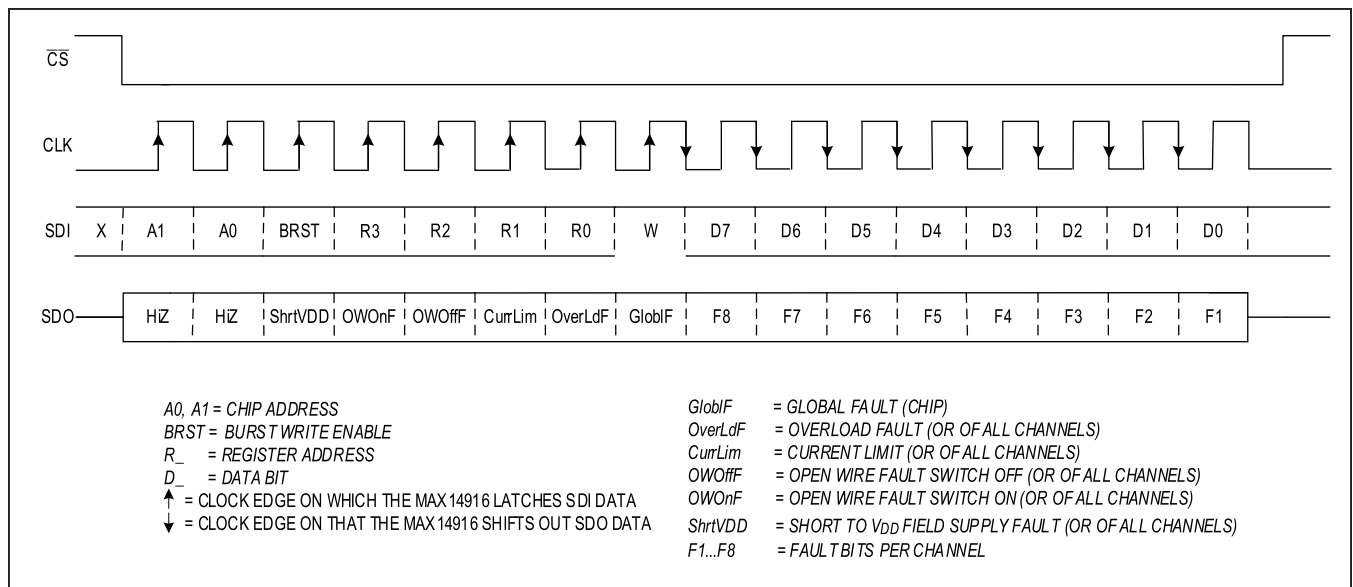

Figure 11. Addressed SPI Single Cycle Write Command

**SPI Burst Write**

In addressed SPI mode (DAISY = low), burst SPI writing is supported. This allows efficient writing of registers that are commonly accessed: SetOUT, SetSLED and SetFLED. Burst SPI uses one SPI cycle and one register address to write to multiple consecutive registers. A burst write is enabled through the BRST bit in the SDI command byte. If the BRST bit is set, the MAX14916 expects an SPI write cycle writing to 2 or 3 registers. The chip-select input ( $\overline{CS}$ ) must be held low during the entire burst write cycle.

The SPI clock continues clocking throughout the burst cycle. Only the initial register address (0x00) is specified in the SDI command byte, followed by two or three bytes of data. The burst length is defined by the number of CLK clocks in the SPI cycle: for a 2 register burst write, 24 clocks are needed if CRC is not used, and 32 clocks are needed with CRC. For a 3 register burst write, 32 SPI clocks are needed without CRC enabled, and 40 clocks with CRC. The burst cycle ends when the  $\overline{CS}$  is driven high.

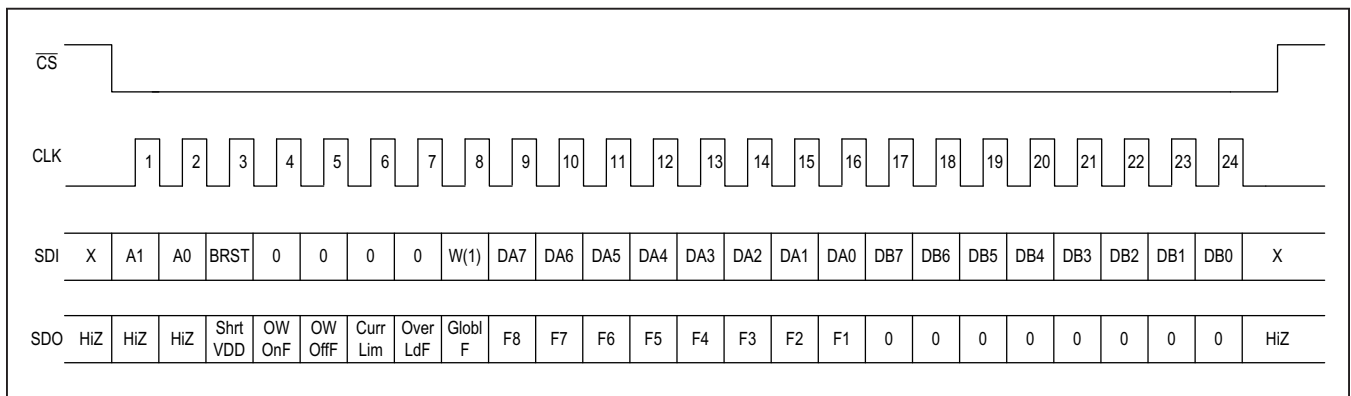

Figure 12. Addressed SPI Two Byte Write Command

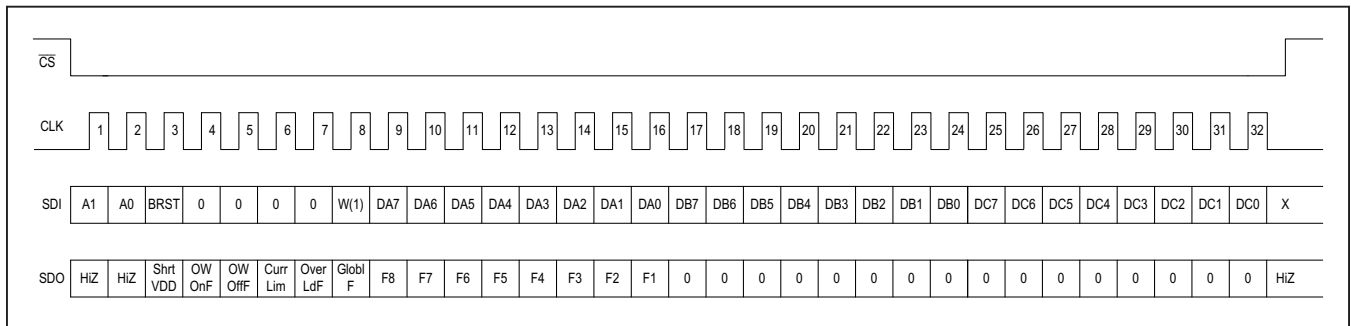

Figure 13. Addressed SPI Three Bytes Burst Write Command

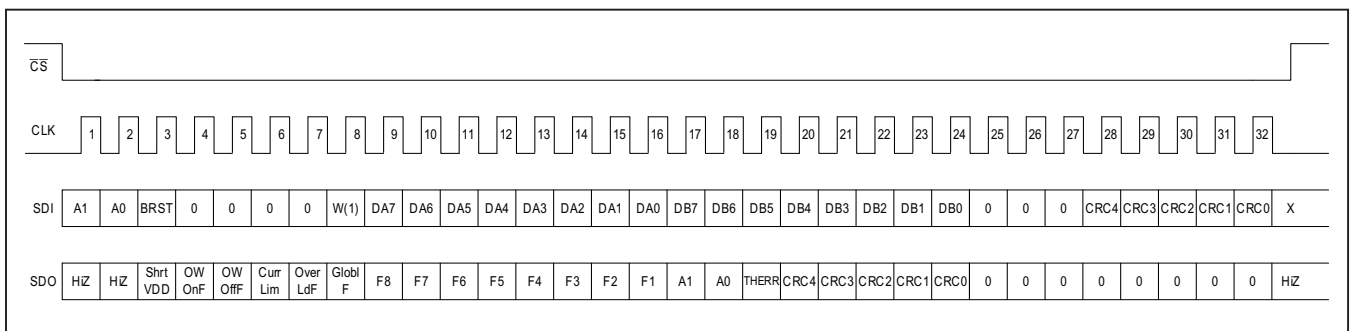

Figure 14. Addressed SPI Two Bytes Burst Write Command with CRC

(\*) CRC\_ bit are calculated on all the data send before CRC\_ bits.

**SPI Burst Read**

In addressed SPI mode (DAISY = low), burst SPI reading is supported. Burst SPI reading allows efficient reading of multiple registers in one SPI cycle. The MAX14916 only supports burst reading of the diagnostic registers OvIChF, CurrLimF, OwOffChF, OwOnChF, ShtVDDChF, GloblErr.

Set the BRST bit in the SDI command byte to signal a burst SPI cycle. The first register address must be 0x04 (OvIChF register) and it must end with the register 0x09 (GloblErr register). Total of six consecutive registers can be read within the burst read cycle. If the burst read command ends before the GloblErr register, a communication error is signaled on COMERR pin.

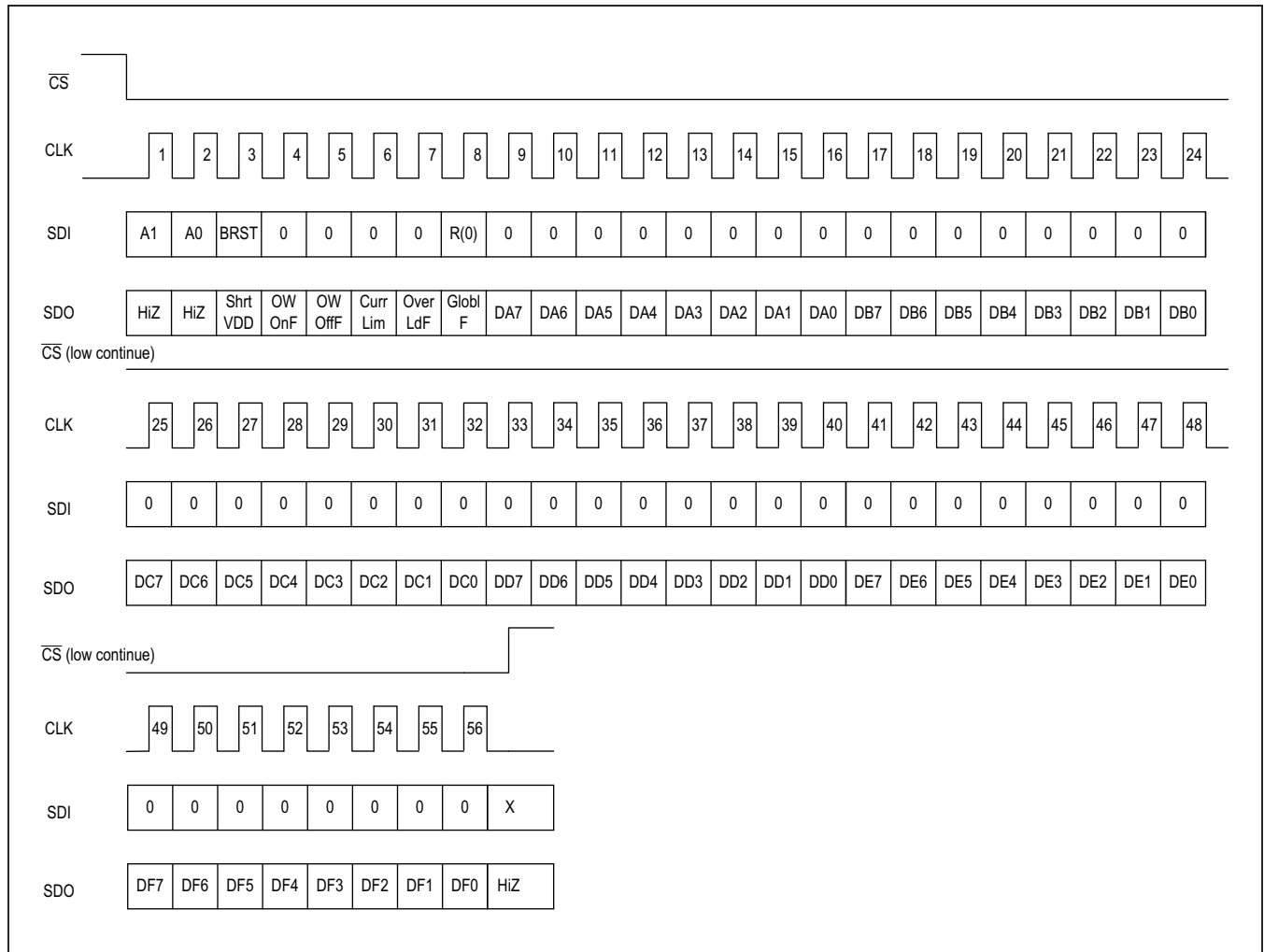

Figure 15. Addressed SPI Burst Read Command

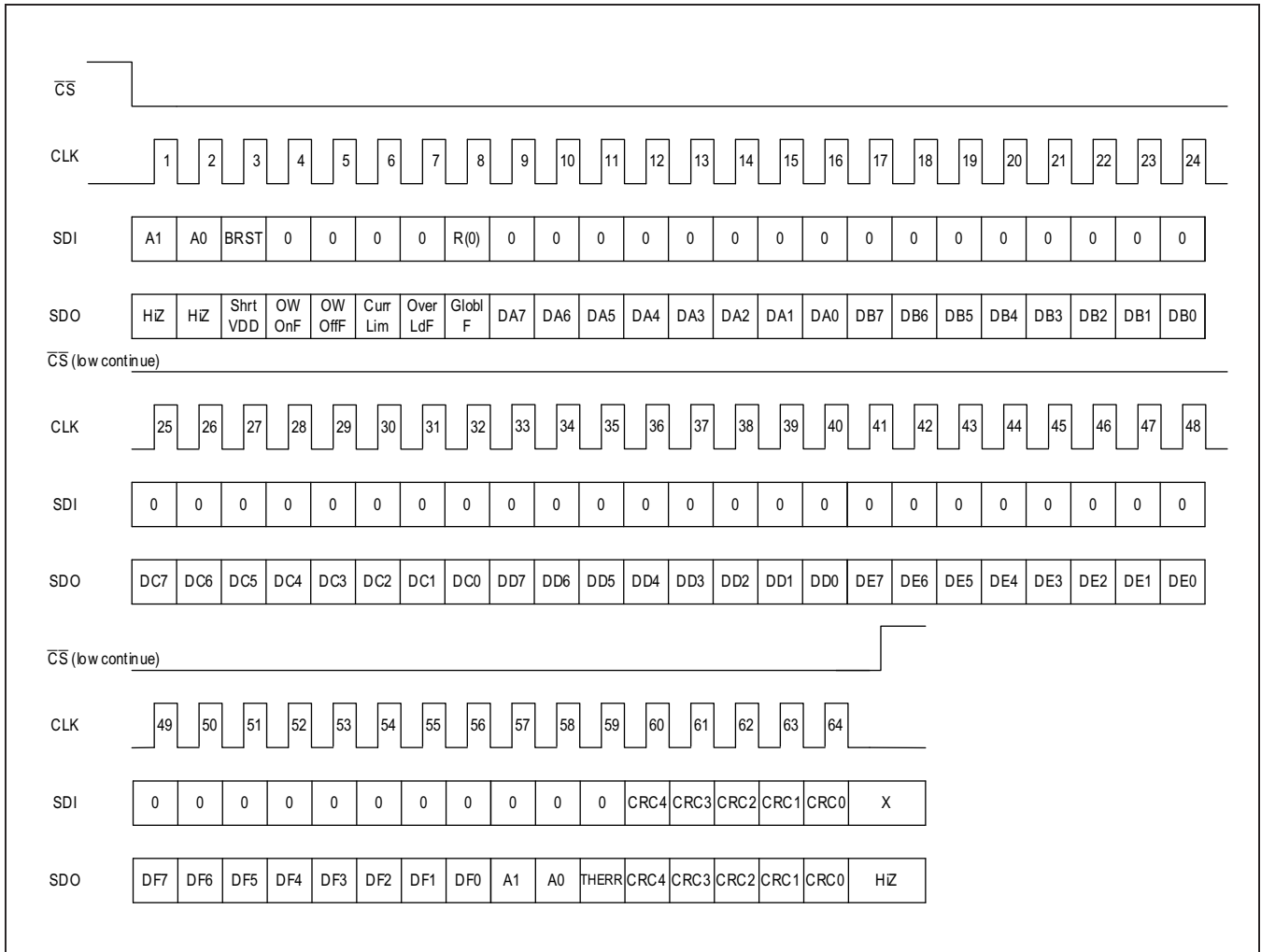

Figure 16. Addressed SPI Burst Read Command with CRC



**Daisy-Chained SPI**

Daisy-chained SPI mode (DAISY = high) allows communication with multiple MAX14916 with one  $\overline{CS}$  signal in one SPI cycle. In daisy-chain mode, register access is not possible. Switching between daisy chain and addressed modes is not supported. Daisy-chain mode only allows turning the OUT\_ switches on/off and reading per channel thermal overload diagnostics as well as chip thermal shutdown.

Figure 18 shows a single daisy chain mode SPI cycle without CRC enabled (CRCEN = low), based on only one device in the SPI chain:

The ON\_ bits turn the OUT\_ switches on. The F\_ bits are per-channel diagnostics, and are the same as the OVL\_ bits in the OvChF register. The F\_ bits are latched and are, therefore, only cleared on the following SPI cycle if the fault has disappeared before the following SPI cycle. The F\_ bits are filtered, so do not go active when a lamp load is detected. In thermal chip shutdown, all F\_ bits are set to 1.

Daisy-chain SPI mode also supports CRC error detection, which lengthens the SPI cycle to 16 CLK clocks per MAX14916.

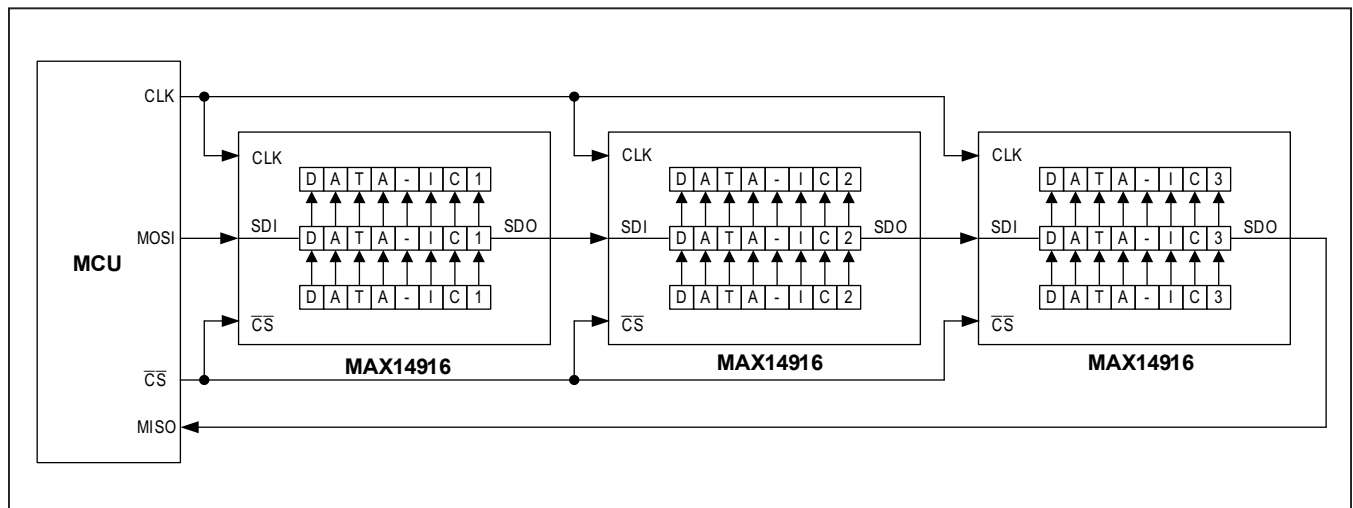

Figure 17. Daisy-Chaining Diagram of Three MAX14916

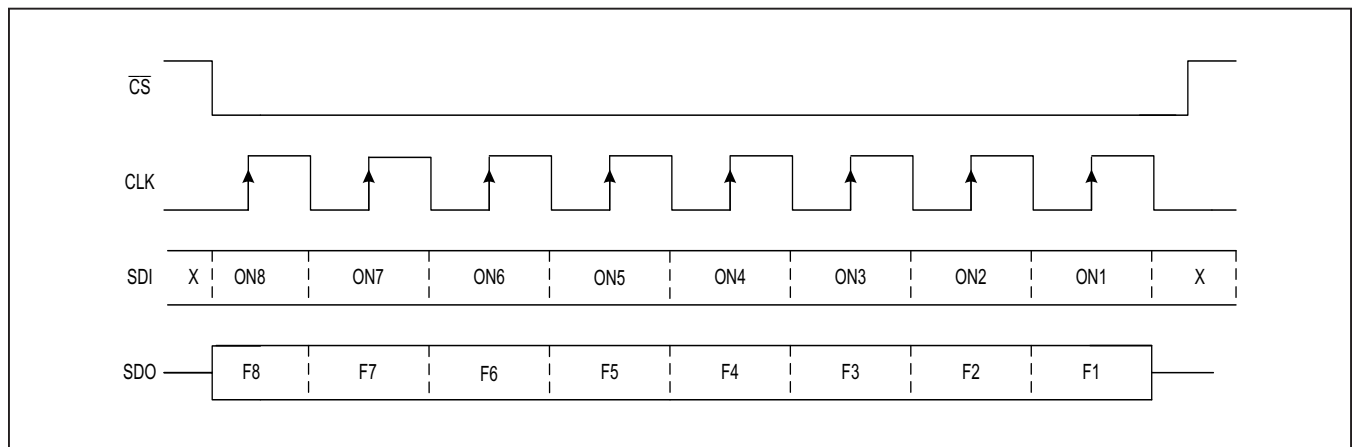

Figure 18. Single Daisy-Chain SPI Command

**Checking of Clocks on the Serial Interface**

In addressed SPI and daisy-chain SPI modes, the MAX14916 checks that the number of clock cycles in one SPI cycle (from falling edge of  $\overline{CS}$  to rising edge of  $\overline{CS}$ ) is a multiple of 8, with 8 clocks minimum for daisy-chain mode and 16 clocks minimum for addressed SPI modes. The expected number of clocks is scaled according to CRCEN setting and Burst mode settings. If the number of clock cycles differs from the expected, then the SPI command is not executed and an SPI error is signaled through the  $\overline{COMERR}$  pin.

**CRC Error Detection on the Serial Interface**

CRC error detection of the serial data can be enabled to minimize incorrect operation/misinformation due to data corruption of the SDI/SDO signals. If error detection is enabled, then the MAX14916:

- 3) Performs error detection on the SDI data that it receives from the controller, and
- 4) Calculates a CRC on the SDO data and appends a check byte to the SDO diagnostics/status data that it sends to the controller.

This ensures that both the data that it receives from the controller (setting/configuration) and the data that it sends to the controller (diagnostics/status) have a low likelihood of undetected errors.

Setting the CRCEN input high enables CRC error detection. A CRC Frame Check Sequence (FCS) is then sent along with each serial transaction. The 5-bit FCS is based on the generator polynomial  $X^5 + X^4 + X^2 + 1$  with CRC starting value = 11111.

When CRC is enabled, the MAX14916 expects a check byte appended to the SDI program/configure data that it receives. The check byte has the following format:

**Table 4. Valid Data Length**

DAISY	CRCEN	R/W BIT	BRST BIT	VALID DATA LENGTH (*)
0	0	1	0	16
0	0	1	1	24 or 32
0	1	1	0	24
0	1	1	1	32 or 40
0	0	0	0	16
0	0	0	1	56
0	1	0	0	24
0	1	0	1	64
1	0	x	x	8xN (**)
1	1	x	x	16xN (**)

(\*) This is the number of CLK rising edges between  $\overline{CS}$  falling and rising edges

(\*\*) N is an integer number of daisy-chained devices

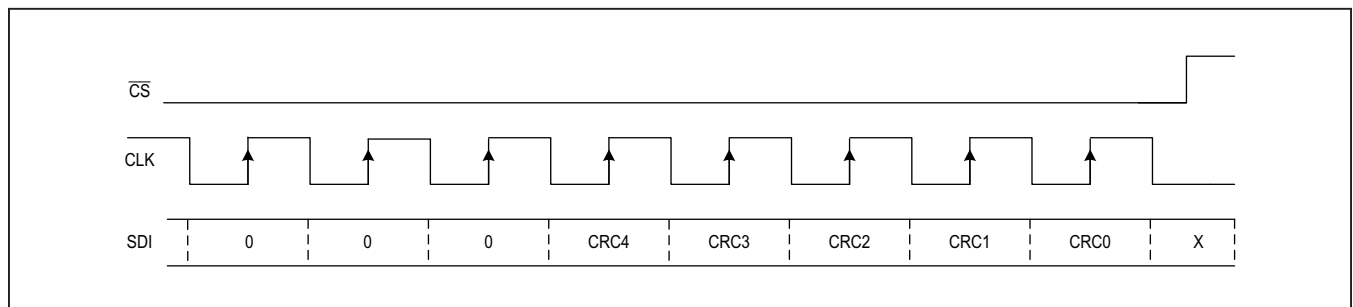

Figure 19. FCS Byte Expected from the SPI Master

The five FCS bits (CR\_) are calculated on all the data sent in one SPI command including the three “0” in the MSBs of the check byte. Therefore, the CRC is calculated from 8 + 3 bits up to 56 + 3 bits in case of burst command. CR0 is the LSB of the FCS.

The MAX14916 verifies the received FCS. If no error is detected, the MAX14916 sets the OUT\_ output switches and/or changes configuration per the SDI data. If a CRC error is detected, then the MAX14916 does not change the OUT\_ outputs and/or does not change its configuration. Instead, the MAX14916 sets the COMERR logic output low (i.e., the open-drain COMERR NMOS output transistor is turned on).

The check byte that the MAX14916 appends to the SDO data has the format seen in [Figure 20](#) when the DAISY pin is low.

A1 and A0 are the level for A1/A0 pins while THERR bit is set when a chip thermal shutdown event has occurred.

CR\_ are the CRC bits that the MAX14916 calculates on the SDO data, including the A1, A0, and THERR bits. This allows the controller to check for errors on the SDO data received from the MAX14916.

The CMERR is set when either a SPI or SYNCH pin WatchDog event has occurred.

The THERR bit is set when either the thermal warning or the thermal shutdown occurs. The VERR bit in FCS byte corresponds to the SupplyErr bit in the Interrupt register.

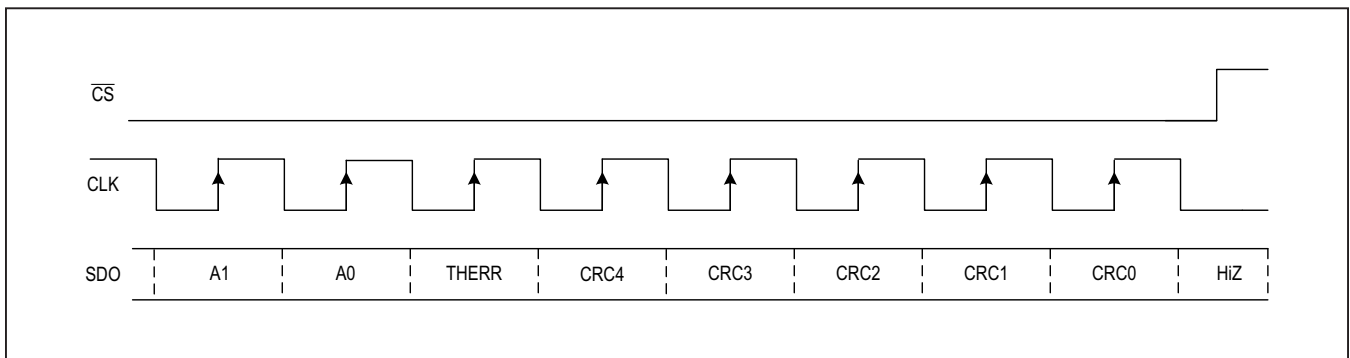

Figure 20. FCS Byte Sent by the MAX14916 to SPI Master (SPI Addressed Mode)

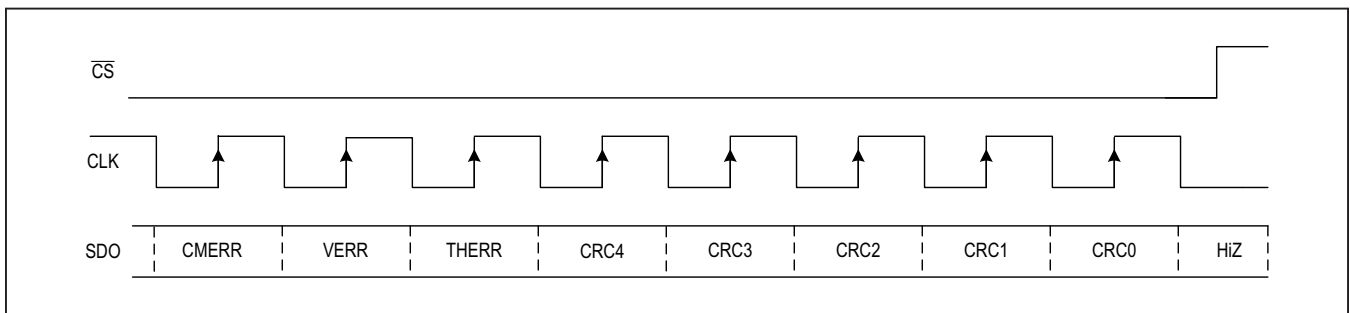

Figure 21. FCS Byte Sent by the MAX14916 to SPI Master in Daisy-Chain Mode

## Register Map

	REGIS- TER ADDRESS	ACCESS TYPE	BIT 7	BIT 6	BIT 5	BIT 4	BIT 3	BIT 2	BIT 1	BIT 0
<a href="#">SetOUT</a>	0x00	R/W	On8	On7	On6	On5	On4	On3	On2	On1
<a href="#">SetFLED</a>	0x01	R/W	FLED8	FLED7	FLED6	FLED5	FLED4	FLED3	FLED2	FLED1
<a href="#">SetSLED</a>	0x02	R/W	SLED8	SLED7	SLED6	SLED5	SLED4	SLED3	SLED2	SLED1
<a href="#">Interrupt</a>	0x03	R	ComErr	SupplyErr	ThErr	ShtVdd- Fault	OWOn- Fault	OWOff- Fault	CurrLim	OverLd- Fault
<a href="#">OvlChF</a>	0x04	R	OVL8	OVL7	OVL6	OVL5	OVL4	OVL3	OVL2	OVL1
<a href="#">CurrLim</a>	0x05	R	CL8	CL7	CL6	CL5	CL4	CL3	CL2	CL1
<a href="#">OwOffChF</a>	0x06	R	OWOff8	OWOff7	OWOff6	OWOff5	OWOff4	OWOff3	OWOff2	OWOff1
<a href="#">OwOnChF</a>	0x07	R	OWOn8	OWOn7	OWOn6	OWOn5	OWOn4	OWOn3	OWOn2	OWOn1
<a href="#">ShtVD- DChF</a>	0x08	R	SHVDD8	SHVDD7	SHVDD6	SHVDD5	SHVDD4	SHVDD3	SHVDD2	SHVDD1
<a href="#">GlobalErr</a>	0x09	R	WDErr	SynchErr	ThrmShutd	VddUvlo	VddWarn	VddNot- Good	VA_UVLO	Vint_UV
<a href="#">OwOffEn</a>	0x0A	R/W	OwOffEn8	OwOffEn7	OwOffEn6	OwOffEn5	OwOffEn4	OwOffEn3	OwOffEn2	OwOffEn1
<a href="#">OwOnEn</a>	0x0B	R/W	OwOnEn8	OwOnEn7	OwOnEn6	OwOnEn5	OwOnEn4	OwOnEn3	OwOnEn2	OwOnEn1
<a href="#">ShtVddEn</a>	0x0C	R/W	ShtVdd En8	ShtVdd En7	ShtVdd En6	ShtVdd En5	ShtVdd En4	ShtVdd En3	ShtVdd En2	ShtVdd En1
<a href="#">Config1</a>	0x0D	R/W	LEDCur- rLim	FLatchEn	FiltrLong	FFilterEn	FLED- Strech0	FLED- Strech0	SLEDSet	FLEDSet
<a href="#">Config2</a>	0x0E	R/W	WDTto1	WDTto0	OWOffCs1	OWOffCs0	ShtVdd Thr1	ShtVdd Thr0	Synch- WDEn	VDDOnThr
<a href="#">Mask</a>	0x0F	R/W	ComErrM	Supply- ErrM	VddOKM	ShtVddM	OWOnM	OWOffM	CurrLimM	OverLdM

**SetOUT Register (0x00)**

SetOUT	BIT 7	BIT 6	BIT 5	BIT 4	BIT 3	BIT 2	BIT 1	BIT 0
Bit Name	On8	On7	On6	On5	On4	On3	On2	On1
POR	0	0	0	0	0	0	0	0
Read / Write	R/W	R/W	R/W	R/W	R/W	R/W	R/W	R/W

**On\_**

Set On\_ = 1 to close the associated OUT\_ high-side switch. Set On\_ = 0 to open the high-side switch.

**SetFLED Register (0x01)**

SetFLED	BIT 7	BIT 6	BIT 5	BIT 4	BIT 3	BIT 2	BIT 1	BIT 0
Bit Name	FLED8	FLED7	FLED6	FLED5	FLED4	FLED3	FLED2	FLED1
POR	0	0	0	0	0	0	0	0
Read / Write	R/W	R/W	R/W	R/W	R/W	R/W	R/W	R/W

**FLED\_**

Set FLEDx = 0 turn FLEDx fault LED off. The FLED register bits only operate if the FLEDSet bits is set in the Config1 register.

**SetSLED Register (0x02)**

SetSLED	BIT 7	BIT 6	BIT 5	BIT 4	BIT 3	BIT 2	BIT 1	BIT 0
Bit Name	SLED8	SLED7	SLED6	SLED5	SLED4	SLED3	SLED2	SLED1
POR	0	0	0	0	0	0	0	0
Read / Write	R/W	R/W	R/W	R/W	R/W	R/W	R/W	R/W

**SLED\_**

Set SLEDx = 1 to turn on the SLEDx status LED. Set SLEDx = 0 turn status LED SLEDx off. The SLED register bits only operate if the SLEDSet bits is set in the Config1 register.

**Interrupt Register (0x03)**

Interrupt	BIT 7	BIT 6	BIT 5	BIT 4	BIT 3	BIT 2	BIT 1	BIT 0
Bit Name	ComErr	SupplyErr	ThrmErr	ShtVddFault	OWOnFault	OWOffFault	CurrLim-Fault	OverLdFault
POR	0	1	0	0	0	0	0	0
Read / Write	R	R	R	R	R	R	R	R

**ComErr**

ComErr is set = 1 when a watchdog timeout for SPI interface or SYNCH pin is detected. If the errors are latched (FLatchEn = 1), the ComErr bit is cleared when GlobalErr register is read and the event has disappeared.

**SupplyErr**

SupplyErr is the logic OR of the VA\_UVLO, Vint\_UV and SupplyInt bits in the GlobalErr register. If the errors are latched (FLatchEn = 1), the SupplyErr bit is cleared when GlobalErr register is read and the event has disappeared.

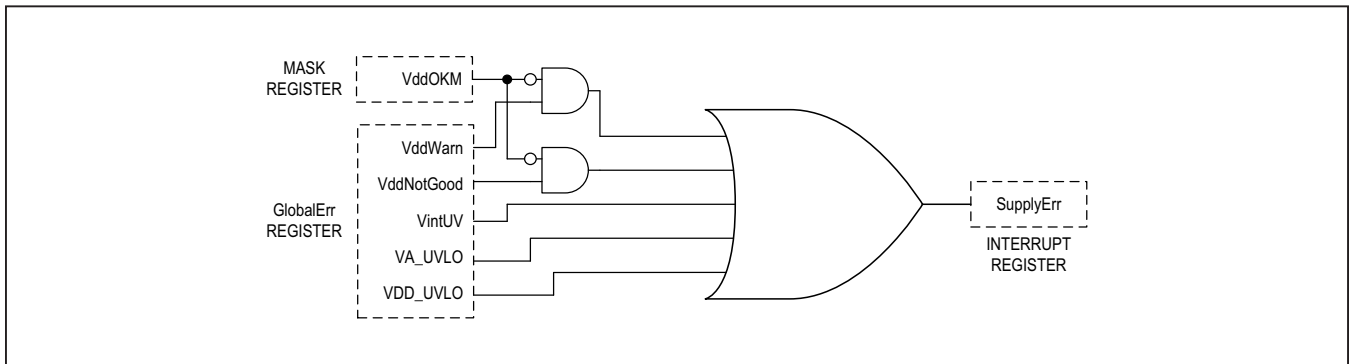

**ThermErr**

ThermErr is set = 1 after MAX14916 enters chip thermal shutdown.

**ShrtVddFault**

ShrtVddFault = 1 when a short to Vdd error was detected on any OUT\_. The detailed channel can be found in the ShrtVddChF register.

**OWOnFault**

OWOnFault = 1 when an open wire fault in On state is detected on any OUT\_. The detailed channel can be found in the OwOnChF register.

**OWOFFault**

OLOffFault = 1 when an open wire fault in Off state is detected on any OUT\_. The detailed channel can be found in the OwOffChF register.

**OverLdFault**

OverLdFault = 1 when an overload occurs on any OUT\_. The detailed channel can be found in the OvIChF register.

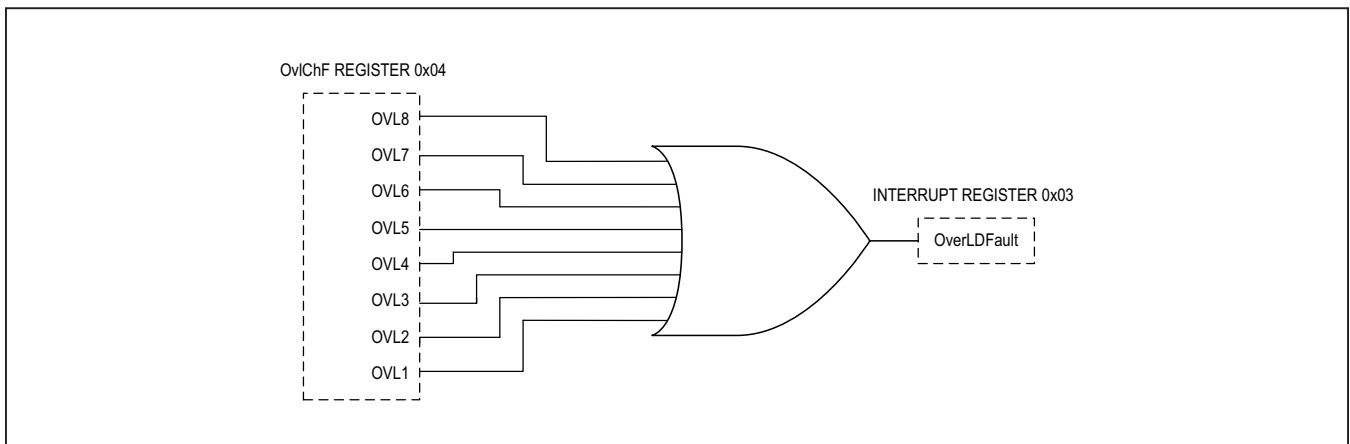

**OvIchF (0x04)**

OvIchF	BIT 7	BIT 6	BIT 5	BIT 4	BIT 3	BIT 2	BIT 1	BIT 0
Bit Name	OVL8	OVL7	OVL6	OVL5	OVL4	OVL3	OVL2	OVL1
POR	0	0	0	0	0	0	0	0
Read / Write	R	R	R	R	R	R	R	R
Reset upon Read	Y	Y	Y	Y	Y	Y	Y	Y

**OVL\_**

OVL\_ = 1 when a thermal overload is detected on OUT\_. All bits can be configured to be real-time or latched (clear on read).

**CurrLimF (0x05)**

CurrLim	BIT 7	BIT 6	BIT 5	BIT 4	BIT 3	BIT 2	BIT 1	BIT 0
Bit Name	CL8	CL7	CL6	CL5	CL4	CL3	CL2	CL1
POR	0	0	0	0	0	0	0	0
Read / Write	R	R	R	R	R	R	R	R

**CL\_**

CL\_ = 1 when a current limit is detected on an OUT\_ switch while the switch is on. All bits can be configured to be real-time or latched (clear on read).

**OwOffChF (0x06)**

CurrLim	BIT 7	BIT 6	BIT 5	BIT 4	BIT 3	BIT 2	BIT 1	BIT 0
Bit Name	OWOff8	OWOff7	OWOff6	OWOff5	OWOff4	OWOff3	OWOff2	OWOff1
POR	0	0	0	0	0	0	0	0
Read / Write	R	R	R	R	R	R	R	R

**OWOff\_**

OWOff\_ = 1 when an open wire fault is detected on OUT\_ in the off state. All bits can be configured to be real-time or latched (clear on read).

**OwOnChF (0x07)**

OwOnChF	BIT 7	BIT 6	BIT 5	BIT 4	BIT 3	BIT 2	BIT 1	BIT 0
Bit Name	OWOn8	OWOn7	OWOn6	OWOn5	OWOn4	OWOn3	OWOn2	OWOn1
POR	0	0	0	0	0	0	0	0
Read / Write	R	R	R	R	R	R	R	R

**OWOn\_**

OWOn\_ = 1 when an open wire fault is detected on OUT\_ in the on state. All bits can be configured to be real-time or latched (clear on read).

**ShtVDDChF (0x08)**

OwOffEn	BIT 7	BIT 6	BIT 5	BIT 4	BIT 3	BIT 2	BIT 1	BIT 0
Bit Name	SHVDD8	SHVDD7	SHVDD6	SHVDD5	SHVDD4	SHVDD3	SHVDD2	SHVDD1
POR	0	0	0	0	0	0	0	0
Read / Write	R	R	R	R	R	R	R	R

**SHVDD\_**

SHVDDx = 1 when an OUTx short to VDD fault in the off state occurred. All bits can be configured to be real-time or latched (clear on read).

**GlobalErr (0x09)**

GlobalErr	BIT 7	BIT 6	BIT 5	BIT 4	BIT 3	BIT 2	BIT 1	BIT 0
Bit Name	WDErr	SynchErr	ThrmShutd	VddUvlo	VddWarn	VddNot-Good	VA_UVLO	Vint_UV
POR	0	0	0	1	1	1	1	1
Read / Write	R	R	R	R	R	R	R	R
Latched	Y	Y	Y	Y	Y	Y	Y	Y

**WDErr**

WDErr is set = 1 when a watchdog timeout is detected, if the watchdog function is enabled through the WDTTo\_ bits. This bit is mapped to the ComErr bit in the Interrupt register .

**SynchErr**

SynchErr is set = 1 when a watchdog timeout for SYNCH pin is detected, if the SYNCH pin watchdog function is enabled through the SynchWDEn bit. This bit is mapped to the ComErr bit in the Interrupt register.

**ThrmShutd**ThrmShutd is set = 1 after the MAX14916 enters thermal shutdown. This bit is mapped to the ThErr bit in the Interrupt register.

**VddUvlo**

VddUvlo bit is set =1 any time  $V_{DD}$  drops below UVLO\_VDD voltage threshold. VddUvlo bit can be cleared by reading GlobalErr register only if  $V_{DD}$  voltage exceeds the VDD\_UVLO voltage threshold.

If SupplyErrM bit is 1,  $V_{DD}$  falling below UVLO\_VDD event triggers the VddUvlo bit and the SupplyErr bit (or VERR bit in SDO signal if daisy-chain mode with CRC operation is selected) in but it will not be signaled by  $\overline{\text{FAULT}}$  pin.

**VddWarn**

VddWarn bit is set = 1 any time  $V_{DD}$  drops below VDD\_WARN voltage threshold. VddWarn bit can be cleared by reading GlobalErr register only if  $V_{DD}$  voltage exceeds the VDD\_WARN threshold. If VddOKM bit is 1,  $V_{DD}$  falling below WARN\_VDD events triggers the VddWarn bit, but they will not be signaled by SupplyErr bit and  $\overline{\text{FAULT}}$  pin.

**VddNotGood**

VddNotGood bit is set =1 any time  $V_{DD}$  drops below VDD\_GOOD voltage threshold. VddNotGood bit can be cleared by reading GlobalErr register only if  $V_{DD}$  voltage exceeds the VDD\_GOOD threshold. If VddOKM bit is 1,  $V_{DD}$  falling below VDD\_GOOD threshold events triggers the VddNotGood bit but they will not be signaled by SupplyErr bit and  $\overline{\text{FAULT}}$  pin.



**VA\_UVLO**

VA\_UVLO is set to 1 when the VA voltage input falls under the VA\_UVLO threshold. If VA\_UVLO is = 1, it can be set = 0 by reading the GlobalErr register when the VA voltage exceeds the VA\_UVLO threshold.

If SupplyErrM bit is 1, VA falling below VA\_UVLO threshold event will trigger the VA\_UVLO flag and the SupplyErr bit but it will not be signaled by FAULT pin.

**Vint\_UV**

Vint\_UV is set to 1 on initial power-up and after the internal supply to the registers falls to a level where the register contents are lost. This signals that a power-on reset has occurred and informs that all register contents were reset. After power-up Vint\_UV = 1 and can be set = 0 by reading the GlobalErr register.

Vint falling below Vint\_UVLO threshold event will always trigger the Vint\_UV flag, the SupplyErr bit and it will be signaled by FAULT pin and READY pin.

**OwOffEn (0x0A)**

OwOffEn	BIT 7	BIT 6	BIT 5	BIT 4	BIT 3	BIT 2	BIT 1	BIT 0
Bit Name	OwOffEn8	OwOffEn7	OwOffEn6	OwOffEn5	OwOffEn4	OwOffEn3	OwOffEn2	OwOffEn1
POR	0	0	0	0	0	0	0	0
Read / Write	R/W	R/W	R/W	R/W	R/W	R/W	R/W	R/W

**OwOffEn\_**

Set OwOffEn\_ = 1 to enable open wire detection with OUT\_ switch in off state. Set OwOffEn\_ = 0 to disable open wire detection on OUT\_ switch in off state. If OwOffEn\_ = 0, the pullup current source is disabled.

**OwOnEn (0x0B)**

OwOnEn	BIT 7	BIT 6	BIT 5	BIT 4	BIT 3	BIT 2	BIT 1	BIT 0
Bit Name	OwOnEn8	OwOnEn7	OwOnEn6	OwOnEn5	OwOnEn4	OwOnEn3	OwOnEn2	OwOnEn1
POR	0	0	0	0	0	0	0	0
Read / Write	R/W	R/W	R/W	R/W	R/W	R/W	R/W	R/W

**OwOnEn\_**

Set OwOnEn\_ = 1 to enable open wire detection with OUT\_ switch ON. Set OwOnEn\_ = 0 to disable open wire on detection on corresponding OUT\_ pin.

**ShVddEn (0x0C)**

ShVddEn	BIT 7	BIT 6	BIT 5	BIT 4	BIT 3	BIT 2	BIT 1	BIT 0
Bit Name	ShVddEn8	ShVddEn7	ShVddEn6	ShVddEn5	ShVddEn4	ShVddEn3	ShVddEn2	ShVddEn1
POR	0	0	0	0	0	0	0	0
Read / Write	R/W	R/W	R/W	R/W	R/W	R/W	R/W	R/W

**ShVddEn\_**

Set ShVddEn\_ = 1 to enable detection of a short to VDD on OUT\_. Set ShVddEn\_ = 0 to disable short to VDD detection on corresponding OUT\_ pin.

**Config1 Register (0x0D)**

Config1	BIT 7	BIT 6	BIT 5	BIT 4	BIT 3	BIT 2	BIT 1	BIT 0
Bit Name	LEDCurrLim	FLatchEn	FiltrLong	FFilterEn	FLED-Strech1	FLED-Strech0	SLEDSset	FLEDSset
POR	0	1	0	1	0	0	1	1
Read / Write	R/W	R/W	R/W	R/W	R/W	R/W	R/W	R/W

**LEDCurrLim**

Set LEDCurrLim = 1 to mask the FLEDs signaling current limiting on a channel when the internal FLED control is active (FLEDSset = 0).

When DAISY is high FLEDs do not show current limiting condition on channel.

**FLatchEn**

Set FLatchEn = 1 enable latching of diagnostic fault bits in the OvChF, CurrLimF, OwOffChF, OwOnChF, ShtVDDChF registers. When the Fault LEDs are controlled internally (FLEDSset = 0), the LED on-time is not affected by this bit, but has a minimum on-time defined by the FLEDStretch\_ bits and is turned off when the fault disappears, if longer than FLEDStretch\_ timing.

**FiltrLong**

Set FiltrLong = 1 to select long blanking time (8ms instead of 4ms) of the diagnostics fault bits in the OwOffChF, OwOnChF, ShtVDDChF. This bit also affects the fault LED turn-on when controlled internally (FLEDSset = 0).

**FFilterEn**

Set FFilterEn = 1 to enable blanking and filtering of the short-to-VDD, open-wire-on, open-wire-off diagnostic bits in the OwOffChF, OwOnChF, ShtVDDChF registers. If FFilterEn = 0, the diagnostics are all real-time (only filtered by 50us filter) and filtering is left to application software. The internal fault LED control (FLEDSset = 0) always uses filtering, this cannot be disabled through FFilterEn.

**FLEDStretch0, FLEDStretch1**

The LEDStretch bits select the minimum on-time for the FLEDs, if controlled internally (FLEDSset = 0), so the eye can catch short events.

FLEDStretch1	FLEDStretch0	MINIMUM LED ON TIME
0	0	Disable
0	1	1s
1	0	2s
1	1	3s

When DAISY pin is high the minimum on-time for the FLED is configured to 2s.

**SLEDSset**

Set SLEDSset = 1 so that the eight status LEDs (SLEDs) are controlled by SetSLED register bits. If SLEDSset = 0, then the eight FLEDs as controlled autonomously by the MAX14916.

When DAISY pin is high the SLEDs are always controlled by the MAX14916.

**FLEDSset**

Set FLEDSset = 1 for the eight fault FLEDs to be controlled by SetFLED register bits. If FLEDSset = 0, then the FLEDs are controlled by the internal fault diagnostics detection: overload, over-current, open-wire and short-to-VDD (if enabled).

When DAISY pin is high the FLEDs are always controlled by the internal overload fault diagnostics detection.

**Config2 Register (0x0E)**

Config2	BIT 7	BIT 6	BIT 5	BIT 4	BIT 3	BIT 2	BIT 1	BIT 0
Bit Name	WDTto1	WDTto0	OwOffCs1	OwOffCs0	ShrtVddThr1	ShrtVddThr0	Synch-WDEn	VDDOnThr
POR	0	0	0	0	0	0	0	0
Read / Write	R/W	R/W	R/W	R/W	R/W	R/W	R/W	R/W

**WDTto1, WDTto0**

The WDTto\_ bits enable and set the timeout of the watchdog timer for both SPI and SYNCH.

WDTto1	WDTto0	SPI WATCHDOG TIMEOUT	SYNCH WATCHDOG TIMEOUT
0	0	Disabled	600ms
0	1	200ms	200ms
1	0	600ms	600ms
1	1	1.2s	1.2s

When DAISY pin is high, SPI and SYNCH watchdog timers are both configured to 1.2s and can be enable shorting to VL respectively pins A0 and A1.

**OwOffCs1, OwOffCs0**

The OwOffCs\_ bits select the pull-up current source current magnitude used for the open wire off detection.

OwOffCs1	OwOffCs0	CURRENT (TYP)
0	0	20µA
0	1	100µA
1	0	300µA
1	1	600µA

**ShrtVddThr1, ShrtVddThr0**

The ShrtVddThr\_ bits select the voltage threshold for Short to VDD detection.

ShrtVddThr1	ShrtVddThr0	CURRENT (TYP)
0	0	9V
0	1	10V
1	0	12V
1	1	14V

**VDDOnThr**

Set VDDOnThr = 1 to select VDD\_GOOD\_R voltage threshold (16V typ) instead of UVLO\_VDD\_R voltage threshold (9V typ) for OUT\_ switch turn-on when VDD rises after a VDD UVLO event.

VDD\_GOOD\_R is used if DAISY pin is high.

**Mask Register (0x0F)**

Mask	BIT 7	BIT 6	BIT 5	BIT 4	BIT 3	BIT 2	BIT 1	BIT 0
Bit Name	ComErrM	SupplyErrM	VddOKM	ShtVddM	OWOnM	OWOffM	CurrLimM	OverLdM
POR	1	0	1	1	1	1	1	0
Read / Write	R/W	R/W	R/W	R/W	R/W	R/W	R/W	R/W

**ComErrM**

Set ComErrM = 1 to disable SPI and SYNCH pin watchdog timeout (if enabled through WDT<sub>to</sub> and SynchWDEn bits) being signaled on the  $\overline{\text{FAULT}}$  output pin. Independent of the ComErrM bit, these conditions will still be shown in the ComErr bit in the Interrupt register and the GlobIF bit in the SDO signal.

If DAISY pin is high, SPI and SYNCH pin watchdog timeout can be enabled by A0/WDEN or/and A1/SWDEn pins. Any watchdog event is signaled in ComErr bit (available if CRCEN is high) while  $\overline{\text{FAULT}}$  pin will not be impacted by ComErr detection.

**SupplyErrM**

Set SupplyErrM = 1 to disable any supply errors and warnings being signaling on the  $\overline{\text{FAULT}}$  output. Independent of the SupplyErrM bit, these conditions will still be shown in the SupplyErr bit in the Interrupt register and the GlobIF bit and in the SDO signal.

If DAISY pin is high, supply errors are not signaled on  $\overline{\text{FAULT}}$  output and information is available only on VERR bit in SDO signal when CRC byte is enabled.

**VddOKM**

Set VddOKM = 1 to disable signaling of VddNotGood and VddWarn bits in SupplyErr bit (and hence also the  $\overline{\text{FAULT}}$  output, if enabled through SupplyErrM). The SupplyErr bit is always active and not affected by the VddOKM bit setting.

If DAISY pin is high supply VddNotGood and VddWarn bits do not affect VERR bit in SDO signal.

**ShtVddM**

Set ShtVddM = 1 to disable per channel short-to-VDD faults being signaling on the  $\overline{\text{FAULT}}$  output. If the Short-to-VDD detection is enabled in the ShtVddEn register, short-to-VDD conditions are still signaled in the ShtVddFault bit and the SPI SDO data, when they occur.

If DAISY pin is high short-to-VDD fault detection is disabled.

**OWOnM**

Set OWOnM = 1 to disable per channel open-wire-on faults being signaled on the  $\overline{\text{FAULT}}$  output. If open-wire-on detection is enabled in the OwOnEn register, open-wire-on conditions will still be signaled in the OWOnFault bit and the SPI SDO data, when they occur.

If DAISY pin is high open-wire-on faults detection is disabled.

**OWOffM**

Set OWOffM = 1 to disable per channel open-wire-off faults being signaled on the  $\overline{\text{FAULT}}$  output. If open-wire-off detection is enabled in the OwOffEn register, open-wire-off conditions will still be signaled in the OWOffFault bit and the SPI SDO data when they occur.

If DAISY pin is high open-wire-off faults detection is disabled.

**CurrLimM**

Set CurrLimM = 1 to disable per channel over-current conditions being signaled on the  $\overline{\text{FAULT}}$  output. Independent of the CurrLimM bit setting, overcurrent conditions will always be signaled in the CurrLim bit and the SPI SDO data when they occur.

If DAISY pin is high overcurrent condition is not signaled.

**OverLdM**

Set OverLdM = 1 to disable per-channel overload faults being signaled on the FAULT output. Independent of the OverLd bit setting, overload faults will always be signaled in the OverLdFault bit and the OvldF bit in the SPI SDO data when they occur.

**Applications Information****Inductive Load Turn-off Energy Clamping**

During turn-off of inductive loads, the free-wheel energy is clamped by the internal  $V_{CL}$  clamps. This energy must be limited to 150mJ (max) at  $T_J = +125^\circ\text{C}$  and  $I_{OUT\_} = -600\text{mA}$  per channel, all channels switching simultaneously. When paralleling OUT channels to achieve higher currents and when the inductive load current exceeds 600mA, the free-wheel energy cannot be dissipated safely by the device. In this case, TVS are required for fast inductive load demagnetization. Either each paralleled output requires a TVS, or one shared TVS can be used with ORing diodes, as shown in the Typical Application Circuit in [Figure 23](#). The TVS clamping voltage must be lower than the difference between  $V_{CL}$  voltage and the maximum  $V_{DD}$  supply voltage expected in operation. For example, with the maximum  $V_{DD} = 32\text{V}$  and  $V_{CL} = 49\text{V}$ , the clamping voltage of an external TVS should be less than  $49\text{V} - 32\text{V} = 17\text{V}$ . The SM30T15AY or similar is recommended.

**Surge Protection**

The MAX14916 has internal protection against  $\pm 1\text{kV}$   $42\Omega/0.5\mu\text{F}$   $1.2\mu\text{s}/50\mu\text{s}$  surges on the OUT\_ pins to GND, if the VDD pins are protected with one TVS. Ensure that the peak voltage of the VDD TVS is below 65V.

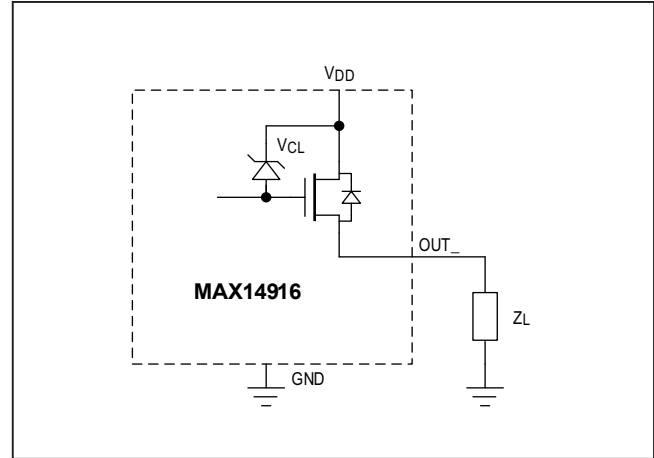

Figure 22. Inductive Load Clamping Scheme

**RF Conducted Immunity**

To ensure that the OUT\_ pins do not produce wrong logic conditions while being off, during IEC61000-4-6 RF immunity testing, connect 10nF capacitors at each OUT\_ to GND.

**Reverse Currents into OUT\_**

If currents flow into the OUT\_ pins, the device heats up due to internal currents that flow through the device from  $V_{DD}$  to GND. The internal currents are proportional to the reverse current into OUT\_. The allowed reverse OUT\_ current depends on  $V_{DD}$ , the ambient temperature and the thermal resistance. At  $25^\circ\text{C}$  ambient temperature the reverse current into one OUT should be limited to 1A at  $V_{DD} = 36\text{V}$  and 1.5A at  $V_{DD} = 24\text{V}$ . Driving higher currents into OUT\_ can destroy the device thermally.

Typical Application Circuit

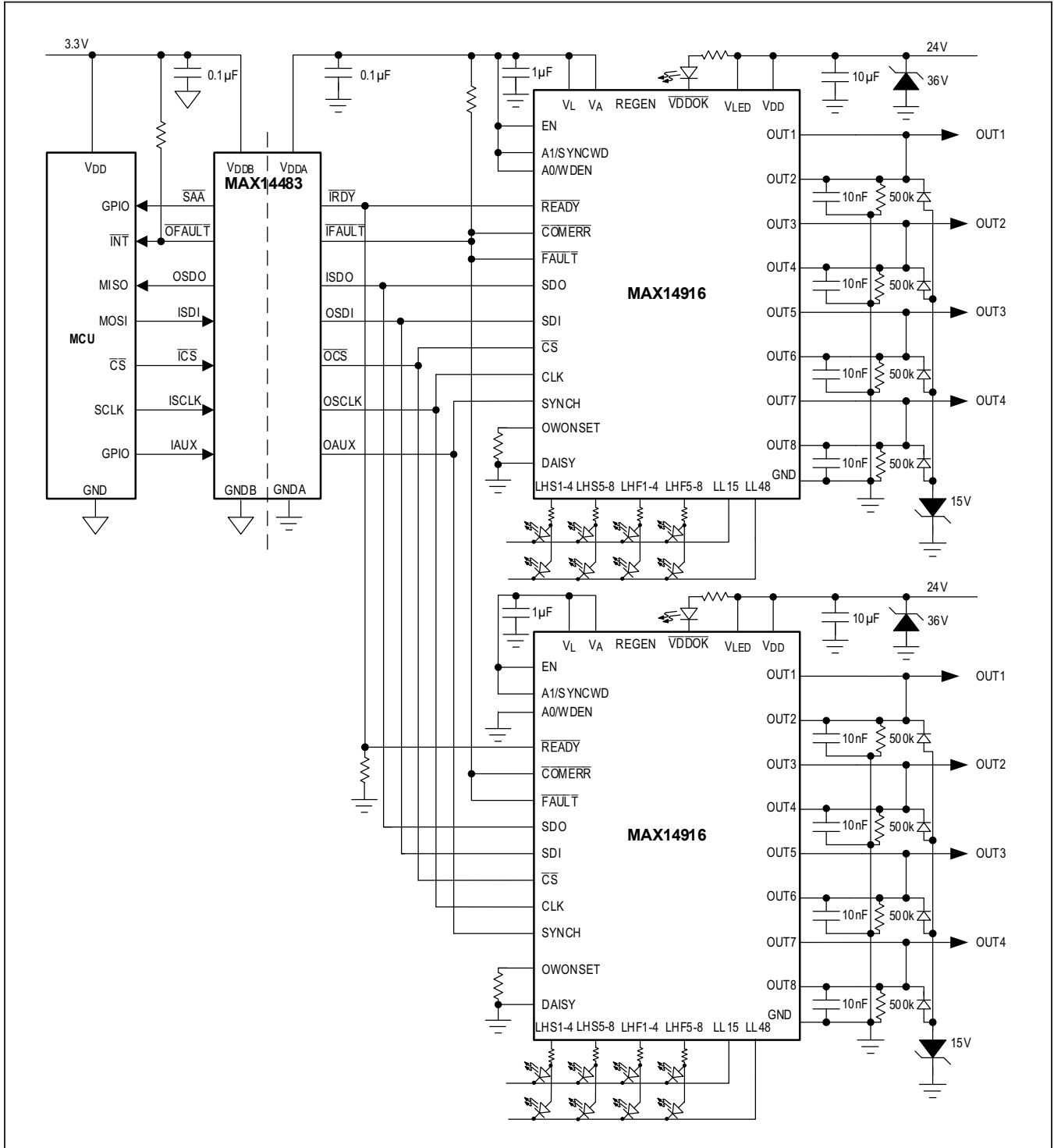

Figure 23. 8 2A-Channel Isolated DO Application Using 6-Channel Digital Isolator

MAX14916

Compact Industrial Octal 1A/Quad 2A  
High-Side Switch with Diagnostics

### Ordering Information

PART	TEMP RANGE	PACKAGE	TOP MARKING	LEAD PITCH
MAX14916AFM+T	-40°C to +125°C	6x6 QFN48	MAX14916AFM	0.4mm
MAX14916AFM+	-40°C to +125°C	6x6 QFN48	MAX14916AFM	0.4mm

+ Denotes a lead(Pb)-free/RoHS-compliant package.

T Denotes tape-and-reel.

## Revision History

REVISION NUMBER	REVISION DATE	DESCRIPTION	PAGES CHANGED
0	8/19	Initial release	—

For pricing, delivery, and ordering information, please visit Maxim Integrated's online storefront at <https://www.maximintegrated.com/en/storefront/storefront.html>.

*Maxim Integrated cannot assume responsibility for use of any circuitry other than circuitry entirely embodied in a Maxim Integrated product. No circuit patent licenses are implied. Maxim Integrated reserves the right to change the circuitry and specifications without notice at any time. The parametric values (min and max limits) shown in the Electrical Characteristics table are guaranteed. Other parametric values quoted in this data sheet are provided for guidance.*