

Axial General Purpose Rectifier
3 A / 50 V to 1000 V

Package Outline Dimensions in mm (inches)

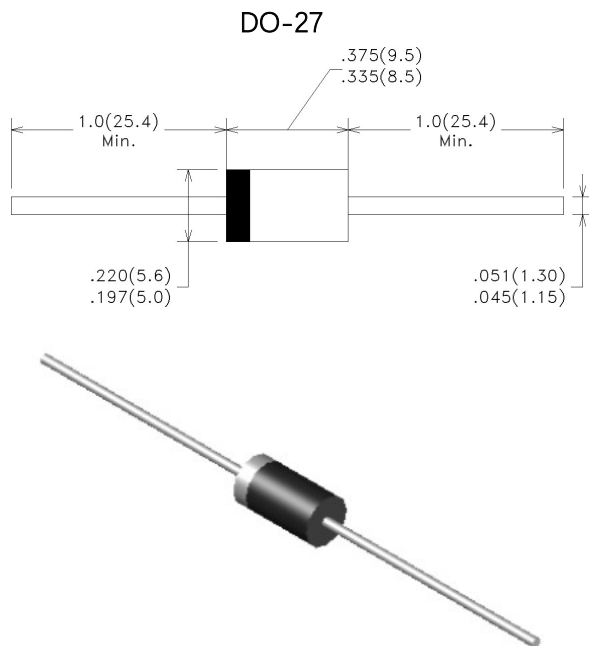

Features

- High reliability
- Low forward voltage drop
- Low leakage current
- High forward surge capability
- Meets MSL level 1, per J-STD-020, LF maximum peak of 260 °C
- Compliant to RoHS Directive 2002/95/EC and in accordance to WEEE 2002/96/EC

Typical Applications

- For use in general purpose rectification of power Supplies.

Mechanical Data

- Case: DO-27 Plastic Package
- Polarity: Color band denotes cathode end

Maximum ratings

Ratings at TA=25°C (unless otherwise specified)

Parameter	Symbol	1N	1N	1N	1N	1N	1N	1N	Unit
		5400	5401	5402	5404	5406	5407	5408	
Maximum recurrent peak reverse voltage	V _{RRM}	50	100	200	400	600	800	1000	V
Maximum RMS voltage	V _{RMS}	35	70	140	280	420	560	700	V
Maximum DC blocking voltage	V _{DC}	50	100	200	400	600	800	1000	V
Maximum average forward rectified current	I _{F(AV)}	3.0							A
Peak forward surge current 8.3 ms single half sine-wave superimposed on rated load	I _{FSM}	150							A
Storage temperature range	T _S	-55 ~ 150							°C
Operating Junction temperature range	T _J	-55 ~ 125							°C
Thermal Resistance (Typical)	R _{thJA}	30							°C /W

Electrical characteristics

Ratings at TA=25°C (unless otherwise specified)

Parameter	Test Conditions	Symbol	1N5400 thur 1N5408	Unit
Maximum forward voltage	I _F =3.0 A	V _F	1.1	V
Maximum DC reverse current at rated DC blocking voltage	TA=25°C	I _R	5.0	μA
	TA=100°C		100	
Typical junction capacitance	4.0 V, 1 MHz	C _j	40	pF

Characteristics Curves

Fig.1 Forward Current Derating Curve

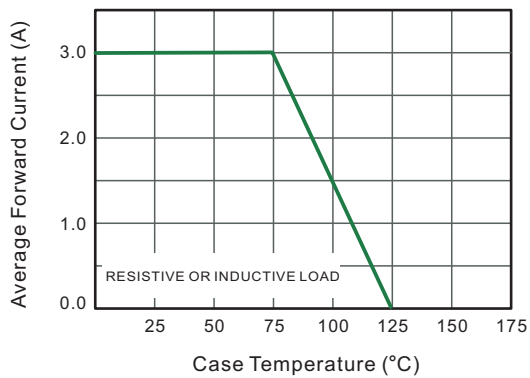

Fig.2 Typical Instantaneous Reverse Characteristics

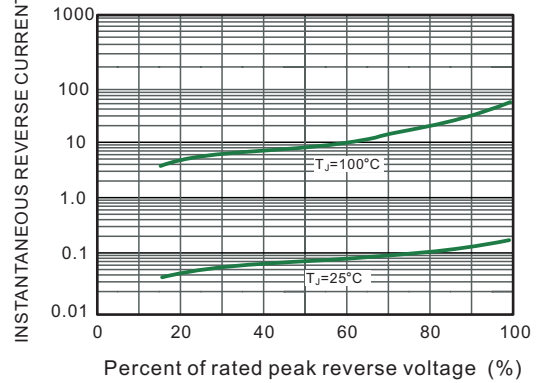

Fig.3 Typical Forward Characteristic

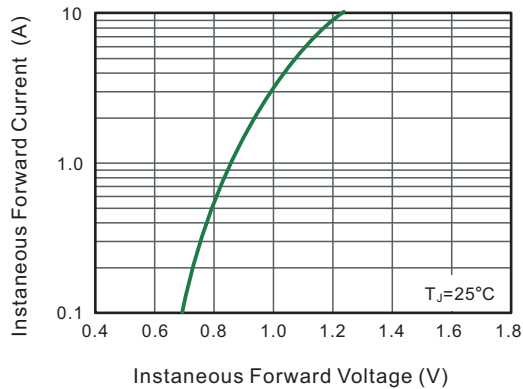

Fig.4 Typical Junction Capacitance

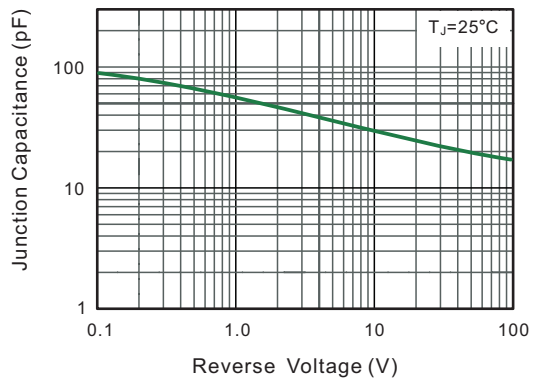

Fig.5 Maximum Non-Repetitive Peak Forward Surge Current

