

■ Description

The WD1117 is available in industrial temperature range low dropout three-terminal regulator. The WD1117 is optimized for low voltage where transient response and minimum input voltage are critical. It provides current limit and thermal shutdown. Its circuit includes a trimmed bandgap reference to assure output voltage accuracy to be within $\pm 1\%$. On-chip thermal shutdown provides protection against a combination of high current and ambient temperature that would create excessive junction temperature.

The WD1117 is available in 1.2V, 1.5V, 1.8V, 2.5V, 3.3V, 5.0V fixed output voltage versions and ADJ output voltage version. The fixed versions integrate the adjust resistors. It is also available in an adjustable version which can set the output voltage with two external resistors. The WD1117 is available in the industry-standard SOT223 and TO252-2 power packages.

■ Features and Benefits

- Current Limit: 1.35A (Typ)
- Output Noise from 10Hz to 10KHz: 0.003% of V_{OUT}
- PSRR at $I_{OUT} = 300\text{mA}$ and $f = 120\text{Hz}$: 70dB
- Output Voltage Accuracy: $\pm 2\%$
- On-chip Thermal Shutdown
- Maximum Quiescent Current: $I_{QMAX} = 6\text{mA}$
- Compatible with Low ESR Ceramic Capacitor
- Operation Junction Temperature: -40°C to $+125^{\circ}\text{C}$

■ Applications

- USB Device
- Add-on Card
- DVD Player
- PC Motherboard

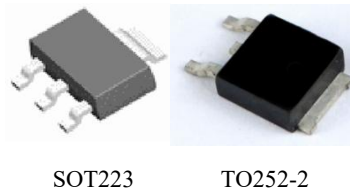

Figure 1. Package Type of WD1117

Pin Configuration

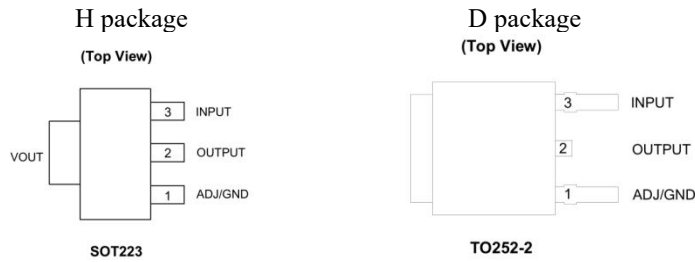

Figure 2. Pin Configuration of WD1117

Pin Description

Pin No.		Symbol	Function
H	D		
1	1	ADJ/GND	Adjust or Ground pin
2, 4	2	Output	Output Voltage pin
3	3	Input	Input Voltage pin

Functional Block Diagram

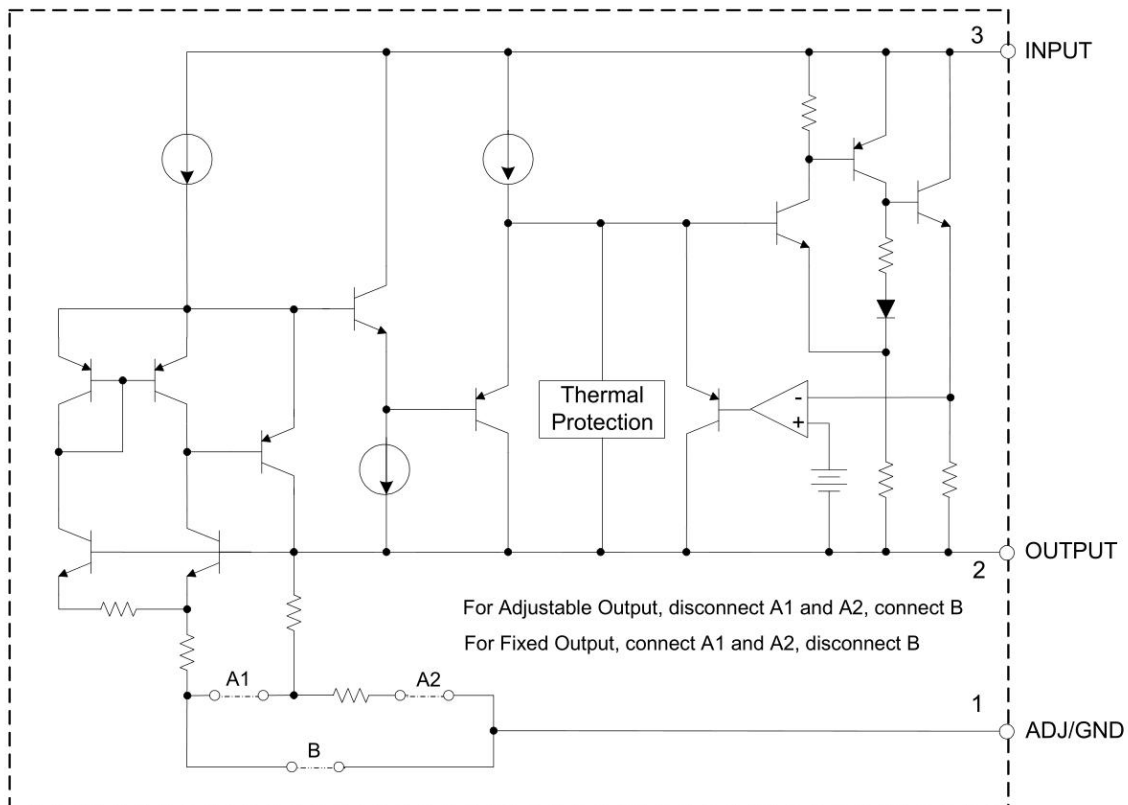

Figure 3. Functional Block Diagram of WD1117

■ Absolute Maximum Ratings (Ta= 25°C)

Parameter	Symbol	Value		Unit
Power Supply Voltage	V _{CC}	18		V
Thermal Resistance (Without Heatsink)	θ_{JA}	SOT-223	125	°C/W
		TO252-2	100	
Thermal Resistance (With Heatsink) ^{note2}	θ_{JA}	SOT-223	100	°C/W
		TO252-2	70	
Thermal Resistance (Junction to Case)	θ_{JC}	SOT-223	15	°C/W
		TO252-2	10	
Operating Junction Temperature	T _J	150		°C
Thermal Shutdown	T _{sd}	160		°C
Thermal Shutdown Hysteresis	T _{hys}	16		°C
Lead Temperature (Soldering, 10s)	T _{LEAD}	260		°C
Storage Temperature Range	T _{STG}	-65 to +150		°C

Note 1: Stresses greater than those listed under “Absolute Maximum Ratings” may cause permanent damage to the device. These are stress ratings only, and functional operation of the device at these or any other conditions beyond those indicated under “Recommended Operating Conditions” is not implied. Exposure to “Absolute Maximum Ratings” for extended periods may affect device reliability.

Note 2: Chip is soldered to 100mm² (10mm*10mm) copper (top side solder mask) on 2oz.2 layers FR-4 PCB with 8*0.5mm vias.

■ Recommended Operating Conditions (T_A=25°C)

Parameter	Symbol	Min	Max	Unit
Power Supply Voltage	V _{CC}		15	V
Operating Temperature	T _A	-40	125	°C

■ Electrical Characteristics

$V_{IN} = V_{OUT} + 2V$, $I_{OUT} = 10mA$, $T_A = 25^\circ C$, unless otherwise specified.

Parameter	Symbol	Conditions	Min	Typ	Max	Unit	
Quiescent Current	I_Q	$I_{OUT} = 0$, FIX version		4	6	mA	
Adjust Pin Current	I_{adj}	ADJ version		60	120	uA	
Adjust Pin Current Change	ΔI_{adj}	$1.5V \leq V_{IN} - V_{OUT} \leq 10V$ ADJ version		0.2	5	uA	
Minimum Load Current	I_{min}	$1.5V \leq V_{IN} - V_{OUT} \leq 10V$ ADJ version		1.7	5	uA	
Output Voltage	V_{OUT}	$1.5V \leq V_{IN} - V_{OUT} \leq 10V$	ADJ	1.225	1.250	1.275	V
			1.2	1.176	1.2	1.224	V
			1.5	1.470	1.5	1.530	V
			1.8	1.764	1.8	1.836	V
			2.5	2.450	2.5	2.550	V
			3.3	3.234	3.3	3.366	V
			5.0	4.900	5.0	5.100	V
Output Voltage	V_{OUT}	$1.5V \leq V_{IN} - V_{OUT} \leq 10V$ -40°C to +125°C	ADJ	1.213	1.250	1.288	V
			1.2	1.164	1.2	1.236	V
			1.5	1.455	1.5	1.545	V
			1.8	1.746	1.8	1.854	V
			2.5	2.425	2.5	2.575	V
			3.3	3.201	3.3	3.399	V
			5.0	4.850	5.0	5.150	V

■ Electrical Characteristics (Continued)

$V_{IN} = V_{OUT} + 2V$, $I_{OUT} = 10mA$, $T_A = 25^\circ C$, unless otherwise specified.

Parameter	Symbol	Conditions	Min	Typ	Max	Unit	
Line Regulation	V_{RLINE}	$1.5V \leq V_{IN} - V_{OUT} \leq 10V$	ADJ		0.001	0.1	%
			FIX		0.5	6	mV
Line Regulation	V_{RLINE}	$1.5V \leq V_{IN} - V_{OUT} \leq 10V$ -40°C to +125°C	ADJ			0.2	%
			FIX			10	mV
Load Regulation	V_{RLOAD}	$V_{IN} - V_{OUT} = 2V$ $1.0mA \leq I_{OUT} \leq 1A$	ADJ		0.4	1.0	%
			FIX		2	15	mV
Dropout Voltage	V_{DROP}	$\Delta V_{OUT} = 1\%$, $I_{OUT} = 0.8A$	SOT223		1.2	1.3	V
			TO252-2		1.3	1.4	V
Current Limit	I_{LIMIT}	---		1.35		A	
Output Noise Voltage	N_o	$10Hz \leq f \leq 10kHz$		0.003		%	
Ripple Rejection	PSRR	$f = 120Hz$, $C_{OUT} = 22\mu F$ $(V_{IN} - V_{OUT}) = 3V$, $I_{OUT} = 300mA$		70		dB	
Temperature Stability	$\Delta V_{OUT} / V_{OUT}$			0.5		%	

Typical Applications Circuit

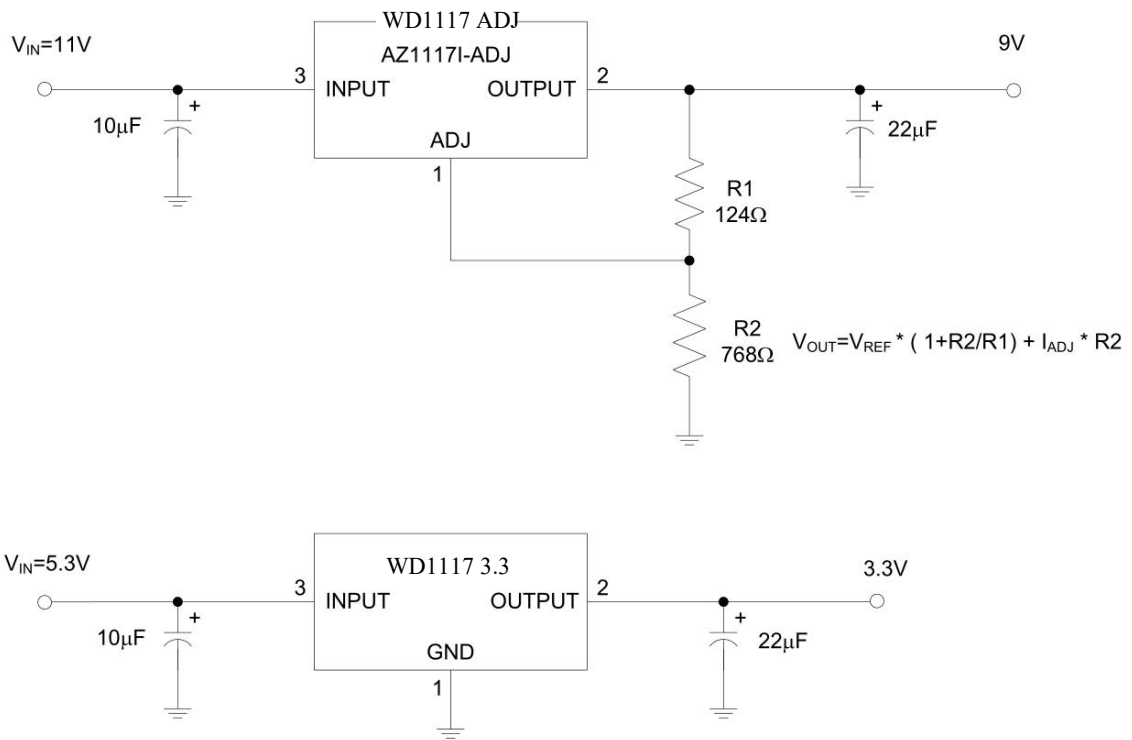
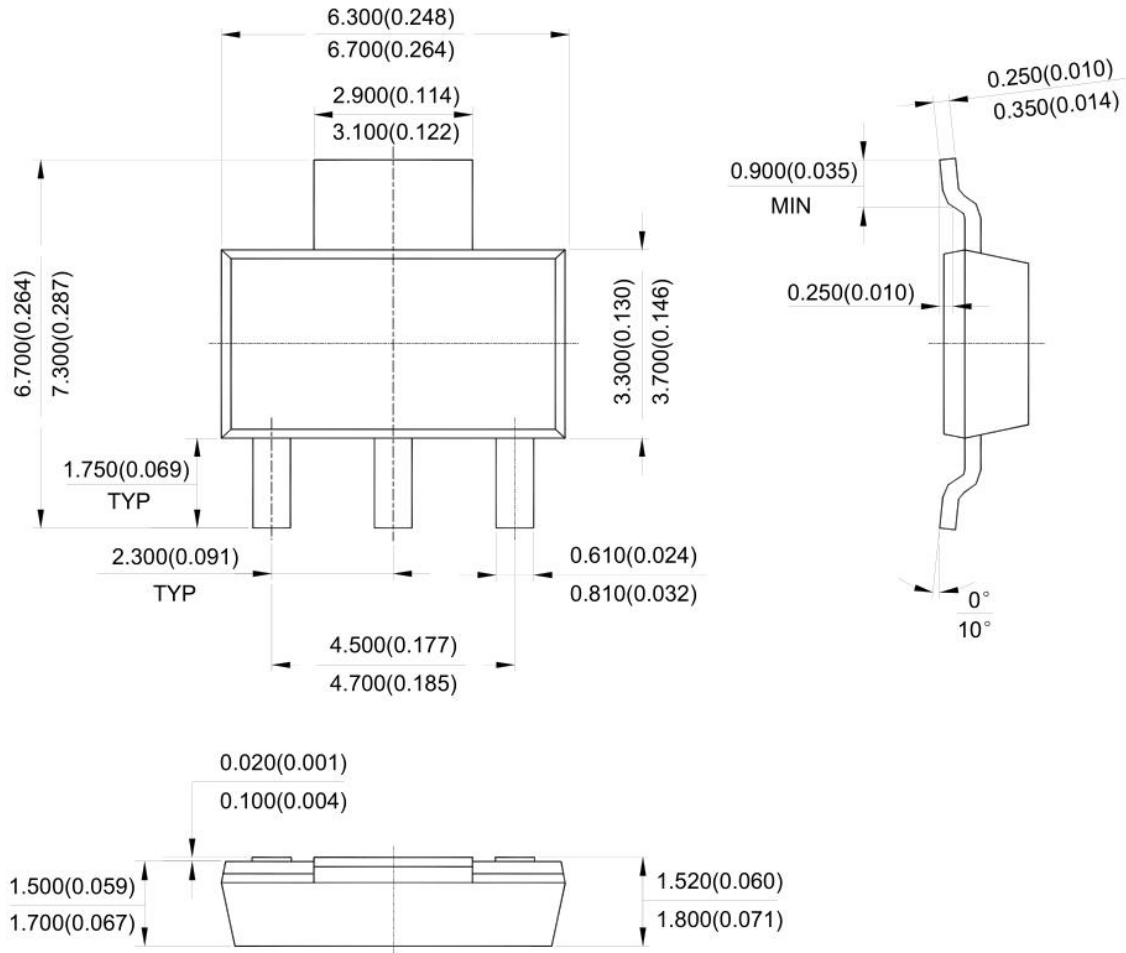

Figure 4. Typical Application of the WD1117

■ Package Outline Dimensions

SOT-223

Unit: mm(inch)



■ Package Outline Dimensions(Continued)

TO252-2

Unit: mm(inch)

