



REV.	ECN NO.	REVISED	DATE

NOTE:

- MATERIAL:
 - HOUSING:PP BLACK
 - SPRING:MUSIC WIRE
(SURFACE PLATING: NI100u"~120u")
- ELECTRIC:
 - DIELECTRIC VOLTAGE: 270V AC ONE SEC LEVEL
 - OPERATING TEMPERATURE: -10° C~ +100° C

SEE ORDERING INFORMATION

ORDERING INFORMATION

BH-AAA-B1AJ022-50

电池盒

电池型号

SMT 180° TYPE

PLATING:
A-Au1U"
J-Ni100U"~120U"
K-Sn100U"~120U"

MATERIAL:
1A-PP BLACK
1B-PA66 BLACK
2A-PPA BROWN
2B-PPA BLACK
3A-PPS BROWN
3B-PPS BLACK
4A-LCP WHITE
4B-LCP BLACK

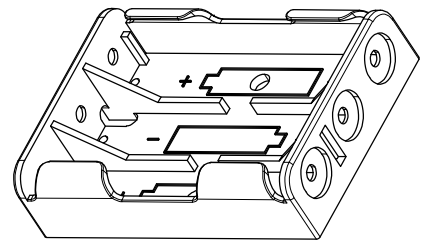
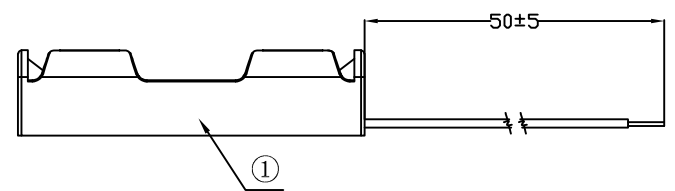
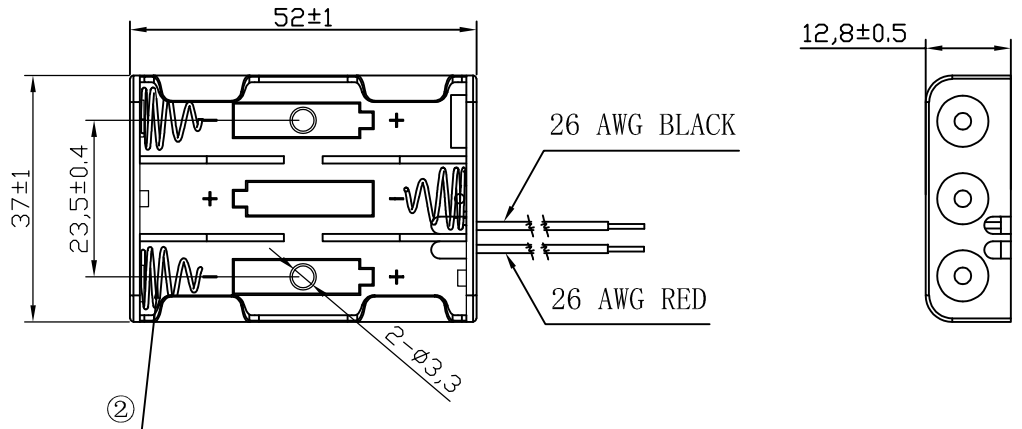

3D

UNLESS OTHERWISE SPECIFIED TOLERANCES		MYOUNG 美阳 www.meiyangdz.com	
DECIMALS: X :±0.30 X.X :±0.25 X.XX :±0.20 X.XXX :±0.10	ANGLES: X :±1° X.X :±0.5°	DSND YangFeng	DATE 2021-11-23
		CHKD ZhouRuicai	DATE 2021-11-23
		APVD XueShunyong	DATE 2021-11-23
WEIGHT:		SCALE:	SIZE: A4
SHEET 1 OF 1		VIEW:	REV.: A/1
		UNIT: mm	OBJECT: MY
		TITLE: 电池盒BH-AAA-3J 新 (26#线长50mm带PH2.0反向插头)	
		PART NO.: BH-AAA-B1AJ022-50	
		DRAW NO.:WD-CP-181	

2	SPRING	3	MUSIC WIRE	Ni-Plating
1	HOUSING	1	PP	BLACK
NO.	PART NAME	Q'TY	MATERIAL	PLATING & COLOR