



REV.	ECN NO.	REVISED	DATE

NOTE:

- 1.MATERIAL:
 a.HOUSING: PC 10%GF
 b.CONTACT: 65Mn
 (SURFACE PLATING: Sn100U"~120U")
 SEE ORDERING INFORMATION

- 2.ELECTRIC:
 a.CONTACT RESISTANCE: 30 MILLIOHMS MAX
 b.INSULATION RESISTANCE: 1000 MEGA OHMS MIN
 c.DIELECTNIC VOLTAGE: 500V AC ONE SEC LEVEL
 d.OPERATING TEMPERATURE: -25° C~ +85° C

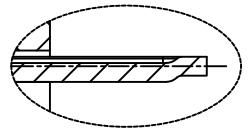
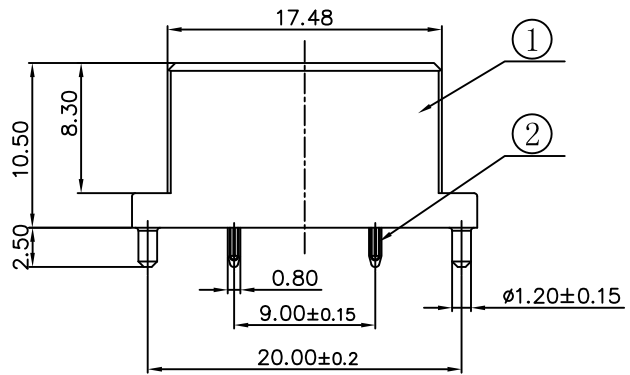
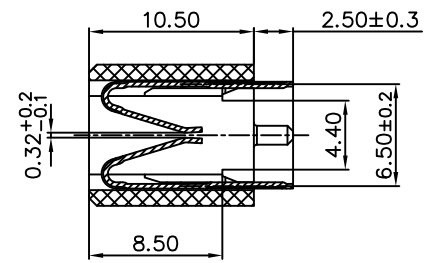
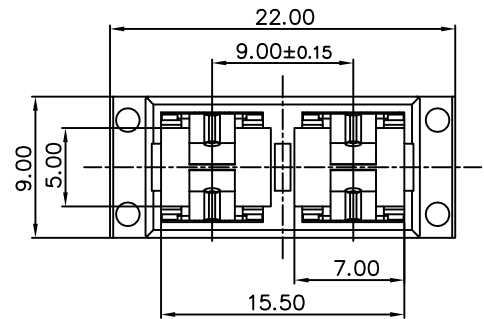

引脚中心位置
4:1

ORDERING INFORMATION
BC-02602-AK001**

接触座系列 —
 BC-02602 系列 —
 DIP 90° TYPE —

PLATING:
 A-Au1U"
 J-Ni100U"~120U"
 K-Sn100U"~120U"

- MATERIAL:
 1A-PBT BLACK
 1B-PA66 BLACK
 2A-PPA BROWN
 2B-PPA BLACK
 3A-PPS BROWN
 3B-PPS BLACK
 4A-LCP WHITE
 4B-LCP BLACK
 5A-PC WHITE

工程部
 2019-11-06
 LQ. HUANG

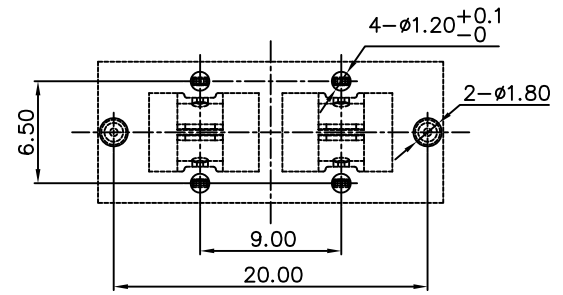

PCB Layout Diagram
Bottom View

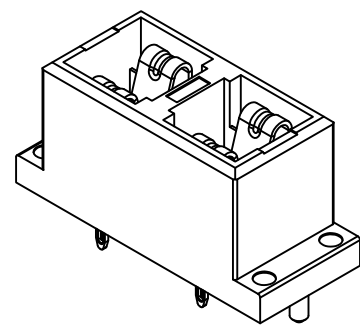

UNLESS OTHERWISE SPECIFIED TOLERANCES		MYOUNG 美阳 www.meiyangdz.com	
DECIMALS: X :±0.30 X.X :±0.25 X.XX :±0.20 X.XXX :±0.10	ANGLES: X :±1° X.X :±0.5°	DSND YangFeng	DATE 2019-11-06
WEIGHT:		CHKD ZhouRuicai	DATE 2019-11-06
SHEET 1 OF 1		APVD XueShunyong	DATE 2019-11-06
SCALE: VIEW:		SIZE: A4	VIEW:
UNIT: mm		REV.: A/0	OBJECT: MY
TITLE: 接触座BC-02602-01 DIP		PART NO.: BC-02602-A5AK001	
DRAW NO.:MY-CP-0216			

2	TERMINAL	4	65Mn T=0.3mm	Sn-plating
1	HOUSING	1	PC 10%GF SABIC503R UL94 V-0	WHITE(RAL9016)
NO.	PART NAME	Q'TY	MATERIAL	PLATING & COLOR