

GT-TC128B-H072BB-L3

G-SWITCH

Operating Force
 A=180gf
 B=250gf
 S=160gf

Switch Height (mm)
 H072BB=7.2mm(黑柄蓝垫 160/250gf)
 H072RB=7.2mm(红柄蓝垫 180gf)
 H077RO=7.7mm(红柄橙垫 180gf)
 H077BB=7.7mm(黑柄蓝垫 250gf)
 H077B0=7.7mm(黑柄橙垫 250gf)

Switch lifetime (Force)
 L3=300,000 Cycles(A、B)
 L5=500,000 Cycles(A)

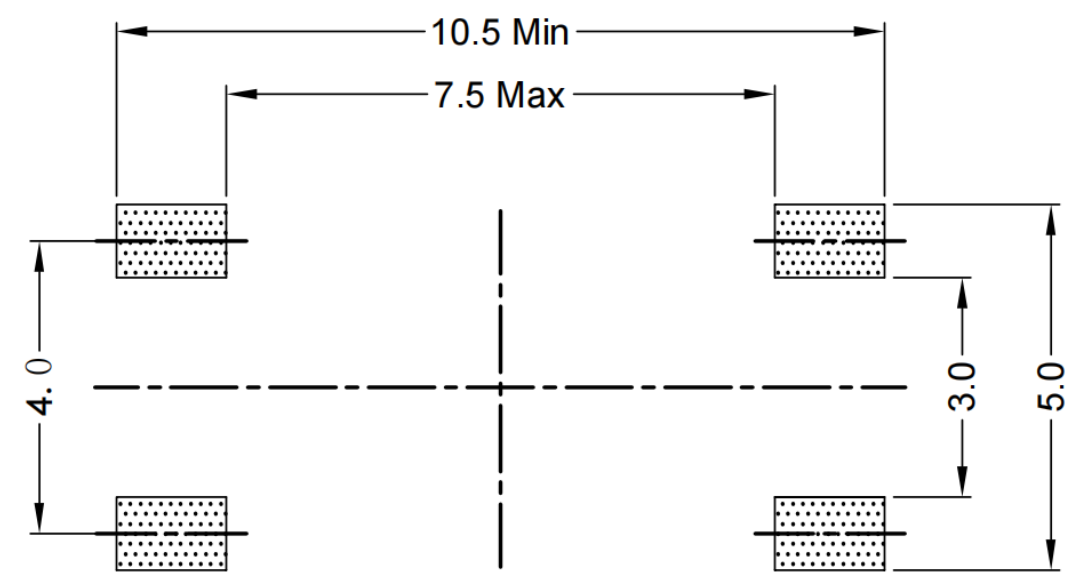
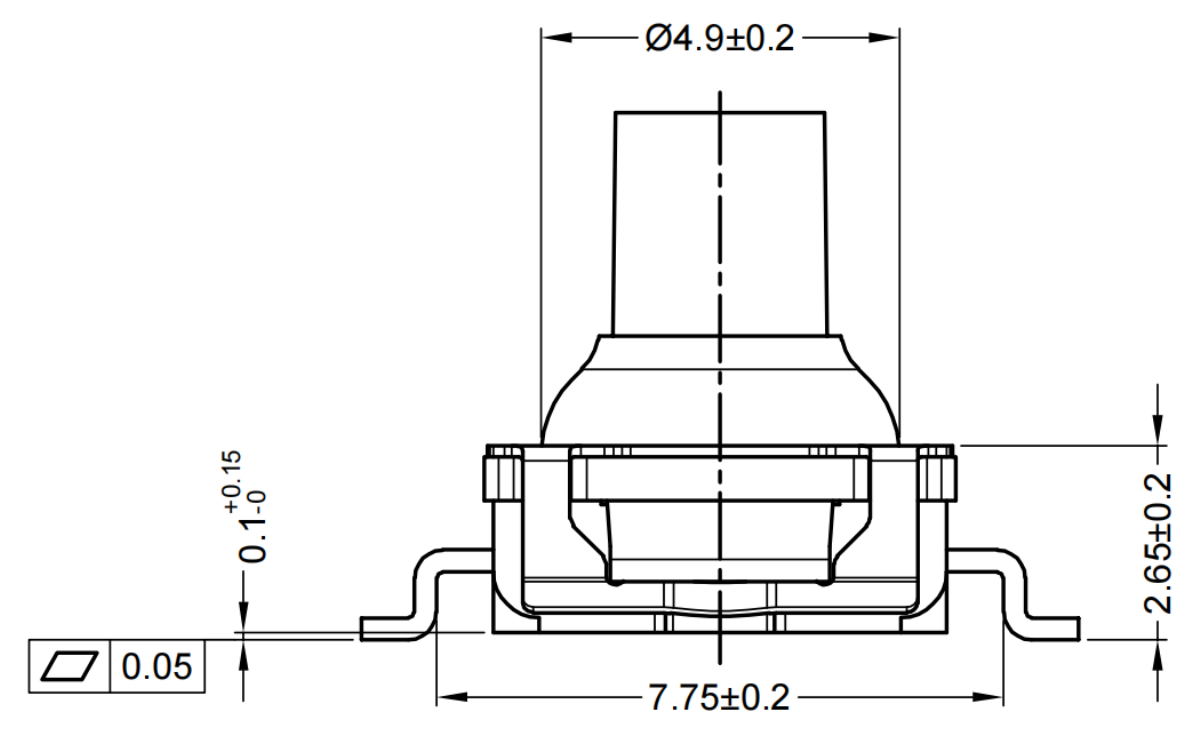

**P.C.B LAND DIMENSION
TOP VIEW**

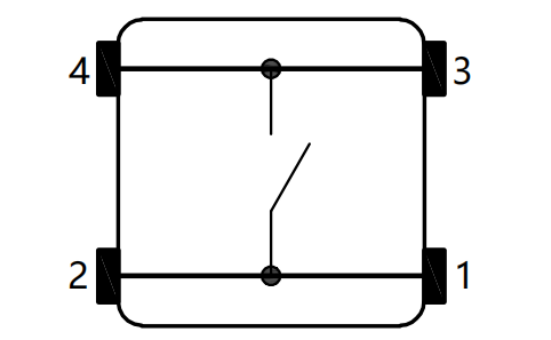

CIRCUIT DIAGRAM

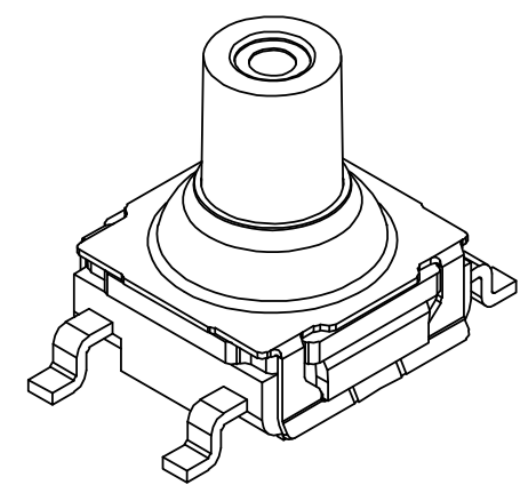

G-Switch Specification:

Operating temperature range: -40°C to +85°C
 Rating: 50mA, 12V DC
 Insulation resistance: 100MΩ min. 100V DC
 Dielectric strength: 250V AC for 1 min
 Contact resistance: 100m Ω max.
 Travel: 0.40±0.2mm
 Water Resistance: IP67

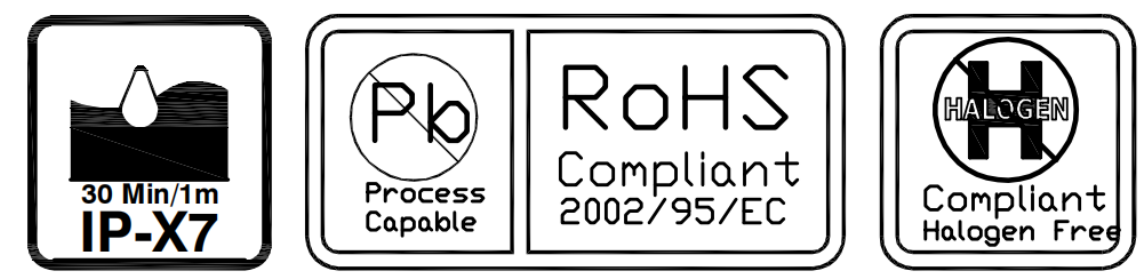

	G-Switch Electronic (HongKong) CO.,Ltd.		
	Unless otherwise specified, Tolerance: X. ±0.30 X.x ±0.20 X.xx ±0.15 X.xxx ±0.10 Angles ±3°	DESIGN FengFengChen CHECKED APPROVED http://www.dg-switch.com TEL:0769-82388879	DATE 2019.05.29 DATE DATE REV.: X1 SCALE: 4:1 SHEET: 1/1