

GT-TC128A-H072RB-L3

G-SWITCH

Operating Force

A=180gf
B=250gf
S=160gf

Switch Height (mm)

H072BB=7.2mm(黑柄蓝垫 160/250gf)
H072RB=7.2mm(红柄蓝垫 180gf)
H077RO=7.7mm(红柄橙垫 180gf)
H077BB=7.7mm(黑柄蓝垫 250gf)
H077B0=7.7mm(黑柄橙垫 250gf)

Switch lifetime (Force)

L3=300,000 Cycles(A、B)
L5=500,000 Cycles(A)

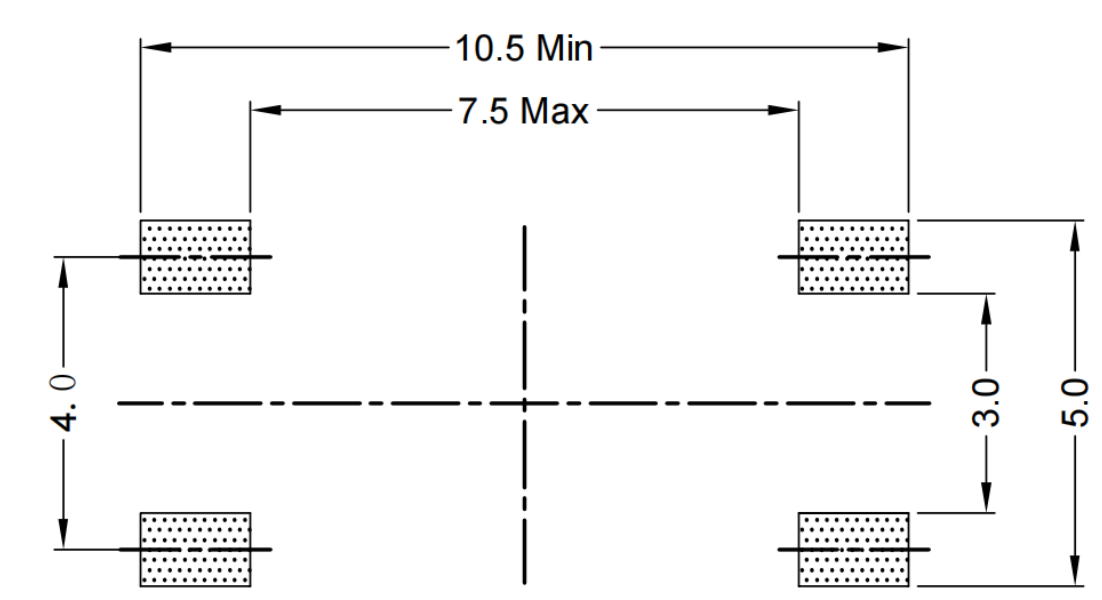
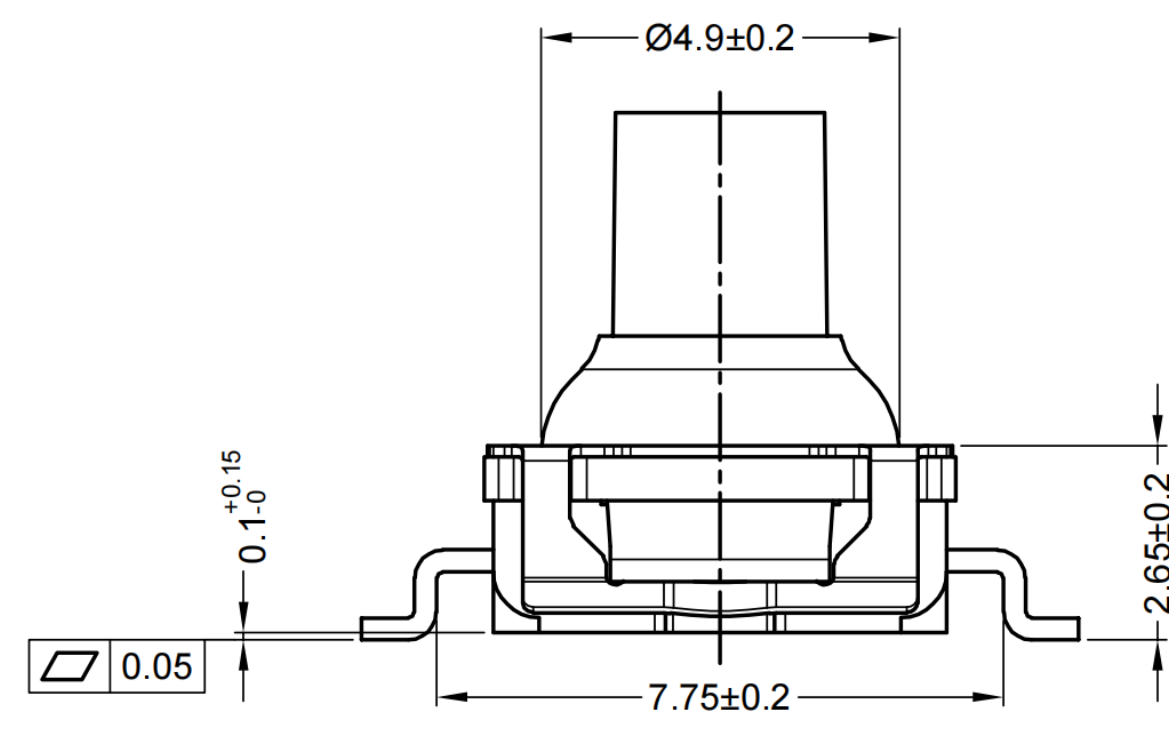

**P.C.B LAND DIMENSION
TOP VIEW**

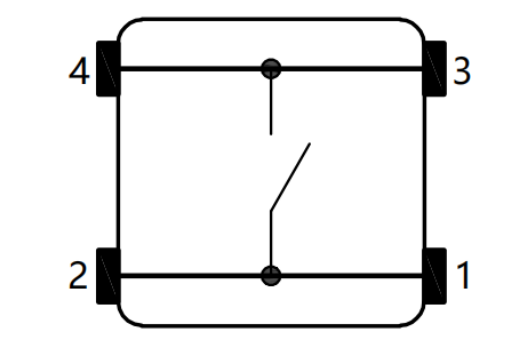

CIRCUIT DIAGRAM

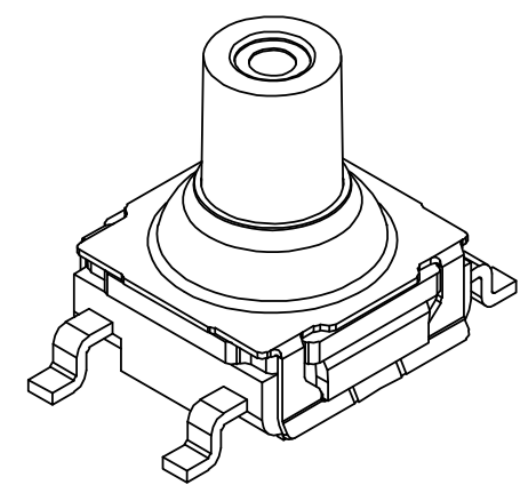

G-Switch Specification:

Operating temperature range: -40°C to +85°C
Rating: 50mA, 12V DC
Insulation resistance: 100MΩ min. 100V DC
Dielectric strength: 250V AC for 1 min
Contact resistance: 100mΩ max.
Travel: 0.40±0.2mm
Water Resistance: IP67

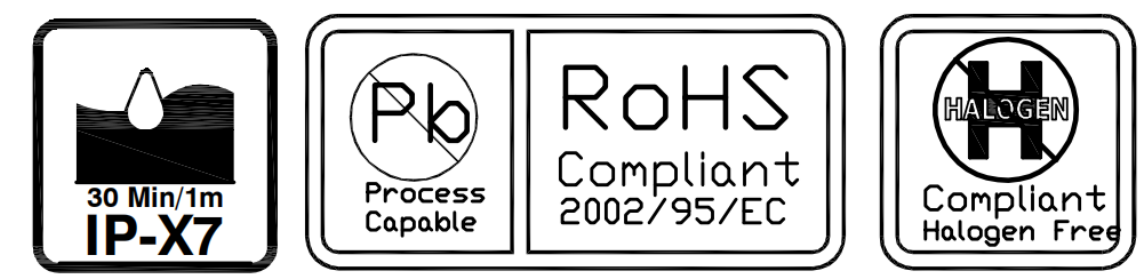

b-Switch 品赞科技® **G-Switch Electronic (HongKong) CO.,Ltd.**

Unless otherwise specified, Tolerance: X. ±0.30 X.x ±0.20 X.xx ±0.15 X.xxx ±0.10 Angles ±3°	DESIGN FengFengChen	DATE 2019.05.29	Molde code:		
	CHECKED	DATE	GT-TC128A-H072RB-L3		
	APPROVED	DATE	REV.: X1	SCALE: 4:1	UNIT: mm
	http://www.dg-switch.com		SIZE: A4	SHEET: 1/1	
TEL:0769-82388879					