

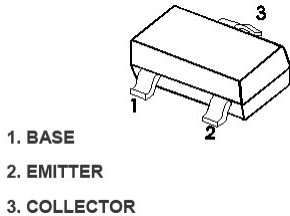

MMBTA42

TRANSISTOR (PNP)

SOT-23



1. BASE
2. EMITTER
3. COLLECTOR

Marking: 1D

特征 Features

- 与 MMBTA92 配对; Complementary to MMBTA92
- 最大功率耗散 350mW; Power Dissipation of 350mW
- 高稳定性和可靠性。High Stability and High Reliability

机械数据 Mechanical Data

- 封装: SOT-23 封装 SOT-23 Small Outline Plastic Package
- 环氧树脂 UL 易燃等级 Epoxy UL: 94V-0
- 安装位置: 任意 Mounting Position: Any

极限值和温度特性(TA = 25°C 除非另有规定)

Maximum Ratings & Thermal Characteristics (Ratings at 25°C ambient temperature unless otherwise specified.)

参数 Parameters	符号 Symbol	数值 Value	单位 Unit
Collector-Base Voltage	V _{CB0}	300	V
Collector-Emitter Voltage	V _{CEO}	300	V
Emitter -Base Voltage	V _{EBO}	5	V
Collector Current-Continuous	I _c	300	mA
Collector Power Dissipation	P _c	350	mW
Junction Temperature	T _j	150	°C
Storage Temperature	T _{stg}	-55-+150	°C
Thermal resistance From junction to ambient	R _{θJA}	357	°C/W

电特性 (TA = 25°C 除非另有规定)

Electrical Characteristics (Ratings at 25°C ambient temperature unless otherwise specified.)

参数 Parameter	符号 Symbols	测试条件 Test Condition	界限 Limits		单位 Unit
			Min	Max	
Collector-base breakdown voltage	V(BR)CBO	I _C =100uA, I _E =0	300		V
Collector-emitter breakdown voltage	V(BR)CEO	I _C =1mA, I _B =0	300		V
Emitter-base breakdown voltage	V(BR)EBO	I _E =10uA, I _C =0	5		V
Collector cut-off current	I _{CB0}	V _{CB} =200V, I _E =0		250	nA
Emitter cut-off current	I _{EBO}	V _{EB} =5V, I _C =0		100	nA
DC current gain	hFE(1)*	V _{CE} =10V, I _C =1mA	60		
	hFE(2)*	V _{CE} =10V, I _C =10mA	100	200	
	hFE(3)*	V _{CE} =10V, I _C =30mA	65		
Collector-emitter saturation voltage	V _{CE(sat)*}	I _C =20mA, I _B =2mA		0.20	V
Base -emitter saturation voltage	V _{BE(sat)*}	I _C =20mA, I _B =2mA		0.90	V
Transition frequency	f _T	V _{CE} =20V, I _C =100mA; f=30MHz	50		MHz

*Pulse test: pulse width ≤ 300us, duty cycle ≤ 2.0%.



Typical characteristics

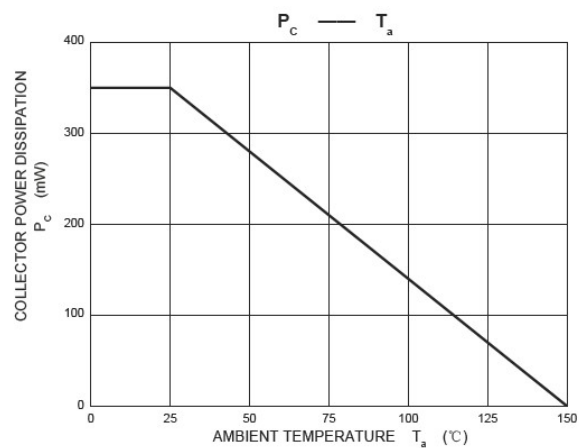
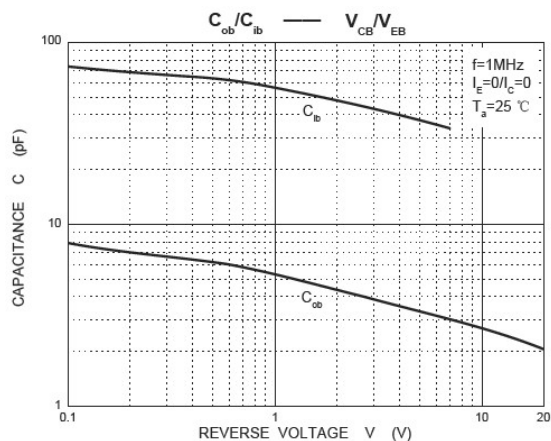
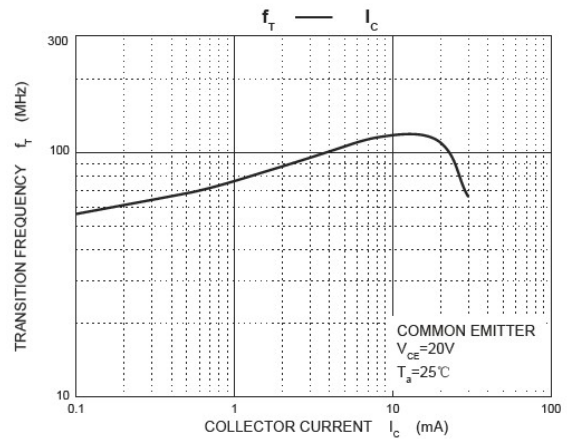
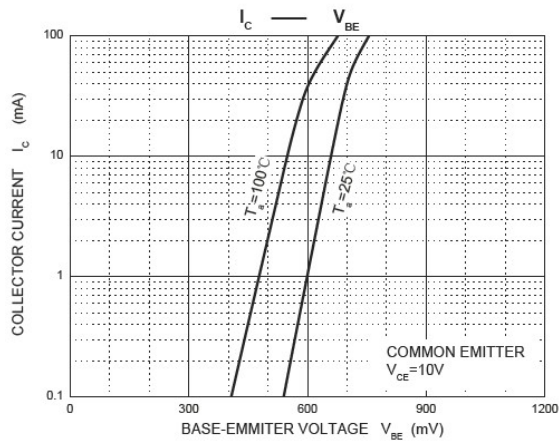
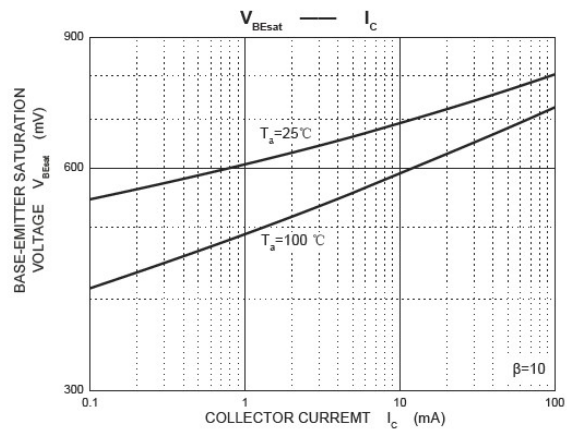
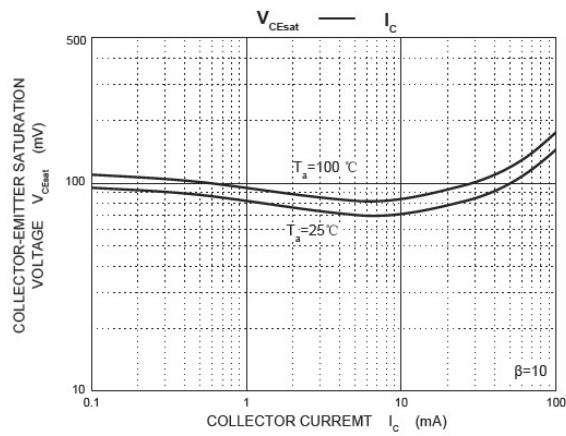
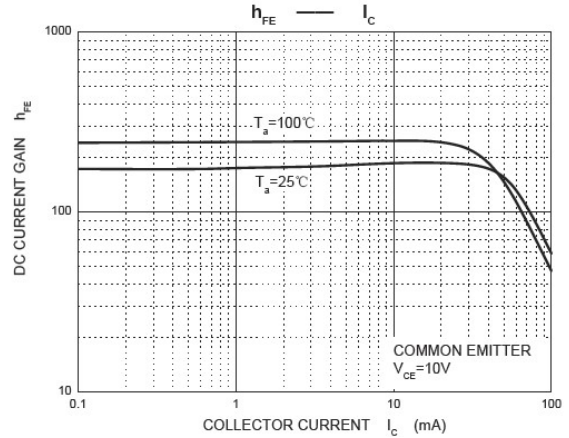
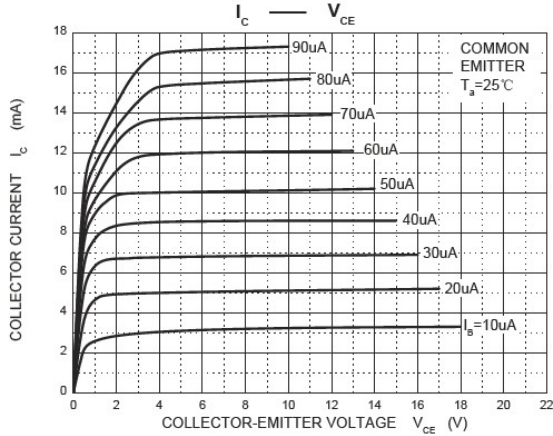



MMBTA42

TRANSISTOR (PNP)

SOT-23 PACKAGE OUTLINE Plastic surface mounted package

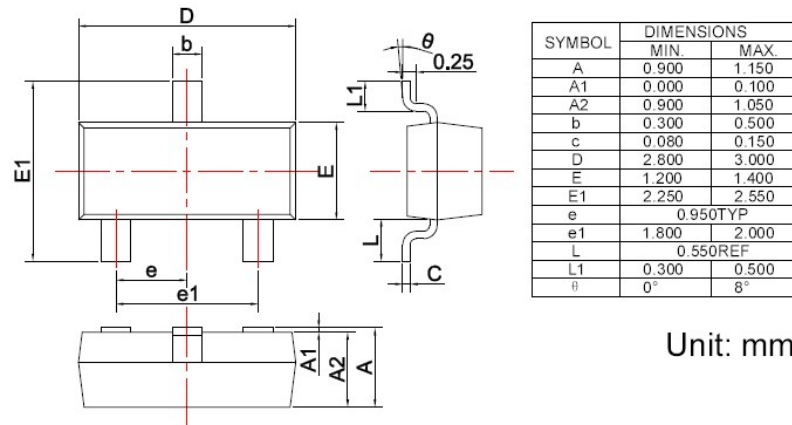

焊盘设计参考 Precautions: PCB Design

Recommended land dimensions for SOT-23 diode. Electrode patterns for PCBs

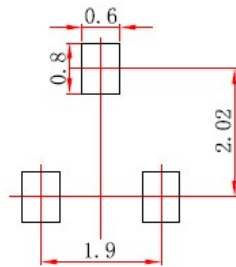

- Note:
1. Controlling dimension: In millimeters.
 2. General tolerance: $\pm 0.05\text{mm}$.
 3. The pad layout is for reference purposes only.