

RoHS  
Compliant



# SPECIFICATION FOR APPROVAL

File No.: Q/FRK 0.GS.E.C23-C12

Product Name      Box-type metallized polyester film capacitor  
Product Type:      C23(CL23 Series)  
Product Code  
Customer  
Customer Code  
Issue Date          2020-03

Xiamen Faratronic Co. Ltd.			Approved by Customer
Drafted	Checked	Approved	



## Xiamen Faratronic Co. Ltd.

Add: 99 Xinyuan Road, Haicang District, Xiamen, China

Marketing/Sales center

TEL: 0086-592-6208620 6208505 6208586

FAX: 0086-592-6208777

Mail: [Vitawang@faratronic.com.cn](mailto:Vitawang@faratronic.com.cn)

[Donny@faratronic.com.cn](mailto:Donny@faratronic.com.cn)

[James@faratronic.com.cn](mailto:James@faratronic.com.cn)

Http: [www.faratronic.com.cn](http://www.faratronic.com.cn)

\*.The specification are the property of Xiamen Faratronic Co.Ltd and shall not be copied or used as commercial purposes without permission.

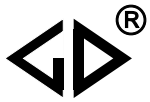

**Version history**

Current version	Date	Author	Change description

## Metallized polyester film capacitor (Box-type)

### ■ Outline Drawing

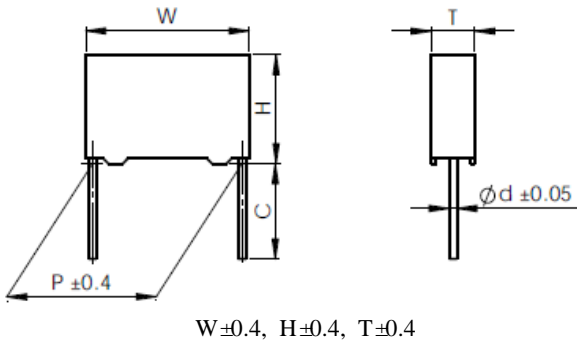

W±0.4, H±0.4, T±0.4

### ■ Features

- High reliability
- Metallized polyester film, non-inductive wound construction
- Plastic case(UL94 V-0), epoxy resin sealing

### ■ Typical application

- by-passing, blocking, coupling, decoupling,
- pulse, logic, timing, oscillator circuits.

### ■ Specifications

Reference Standard	GB 7332 (IEC 60384-2)					
Climatic Category	55/105/56					
Rated temperature	85°C					
Operating temperature	-55°C~105°C (+85°C to +105°C: decreasing factor 1.25% per °C for $U_R$ )					
Rated Voltage	63V, 100V, 250V, 400V, 630V, 1 000V					
Capacitance Range	0.0010 $\mu$ F~47.0 $\mu$ F					
Capacitance Tolerance	$\pm$ 5% (J), $\pm$ 10% (K), $\pm$ 20% (M)					
Voltage Proof	1.6 $U_R$ (5s)					
Dissipation Factor	$\leq$ 1.0% (20°C,1kHz)					
Insulation Resistance	$U_R > 100V$	$R \geq 30\,000M\Omega$ , $RC_N \geq 10\,000\,s$ ,	$C_R \leq 0.33\mu F$ , $C_R > 0.33\mu F$	(20°C,100V,1min)		
	$U_R \leq 100V$	$R \geq 3\,750M\Omega$ , $RC_N \geq 1\,250s$ ,	$C_N \leq 0.33\mu F$ , $C_N > 0.33\mu F$	(20°C,10V,1min)		
Maximum Pulse Rise Time(dV/dt) If the working voltage( $U$ ) is lower than the rated voltage( $U_R$ ),the capacitor can be worked at a higher dV/dt. In this case, the maximum allowed dV/dt is obtain by multiplying the right value with $U_R/U$ .	$U_R(V)$	dV/dt (V/ $\mu$ s)				
		P=7.5	P=10.0	P=15.0	P=22.5	P=27.5
	63	7.5	6	3	2	1
	100	15	9	5	3	2
	250	30	20	12	8	5
	400	40	30	20	10	7
630	50	40	25	12	10	
1 000	70	60	30	15	12	

### ■ Part number system

The 15 digits part number is formed as follow:

1	2	3	4	5	6	7	8	9	10	11	12	13	14	15
C	2	3												

Digit 1 to 3      Series code

C23=CL23

Digit 4 to 5      DC rated voltage

1J=63V    2A=100V    2C=160V    2E=250V    2G=400V    2J=630V    3A=1 000V

Digit 6 to 8      Rated capacitance value

For example: 103=10×10<sup>3</sup> pF= 0.01μF

Digit 9            Capacitance tolerance

J=±5%,K=±10%, M=±20%

Digit 10          Lead pitch

3=7.5mm    4=10.0mm    6=15.0mm    9=22.5mm    B=27.5mm

Digit 11          Internal use

Digit 12 to 15    Lead form and packaging code

**Table 1 Lead form and packaging code**

Digit 12		Digit 13		Digit 14		Digit 15	
code	explanation	code	explanation	code	explanation	code	explanation
A	ammo-pack	3	F=7.5mm	0	straight	1	each cap. among two consecutive holes P3=12.7mm,H=18.5mm (For pitch=7.5mm)
		4	F=10.0mm			5	P3=25.4mm;H=18.5mm (For pitch=10/15mm)
		6	F=15.0mm				
C	straight lead “C” in the figure above	code	explanation			0	Length tolerance ±0.5mm Or standard length
		00	standard lead length (18mm~26mm)				
		45	lead length 4.5mm				
Note: Recommend short lead due to long lead could deform easily.							

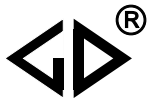

■ **Dimensions (mm)**

Pattern II (Reduced sizes)

63Vdc (40Vac)						
C <sub>N</sub> (μF)	W ±0.4	H ±0.4	T ±0.4	P ±0.4	d	Part number
0.47	10.5	8.5	3.5	7.5	0.5	C231J474-3S****
0.68	10.5	9.0	4.0	7.5	0.6	C231J684-3S****
1.0	10.5	11.0	5.0	7.5	0.6	C231J105-3S****
1.5	10.5	12.0	6.0	7.5	0.6	C231J155-3S****
1.8	10.5	12.0	6.0	7.5	0.6	C231J185-3S****
0.10	13.0	9.0	4.0	10.0	0.6	C231J104-4S****
0.15	13.0	9.0	4.0	10.0	0.6	C231J154-4S****
0.22	13.0	9.0	4.0	10.0	0.6	C231J224-4S****
0.33	13.0	9.0	4.0	10.0	0.6	C231J334-4S****
0.47	13.0	9.0	4.0	10.0	0.6	C231J474-4S****
0.68	13.0	9.0	4.0	10.0	0.6	C231J684-4S****
1.0	13.0	9.0	4.0	10.0	0.6	C231J105-4S****
1.5	13.0	11.0	5.0	10.0	0.6	C231J155-4S****
1.8	13.0	12.0	6.0	10.0	0.6	C231J185-4S****
2.2	13.0	12.0	6.0	10.0	0.6	C231J225-4S****
0.68	17.5	11.0	5.0	15.0	0.8	C231J684-6S****
1.0	17.5	11.0	5.0	15.0	0.8	C231J105-6S****
1.5	17.5	11.0	5.0	15.0	0.8	C231J155-6S****
1.8	17.5	11.0	5.0	15.0	0.8	C231J185-6S****
2.2	17.5	11.0	5.0	15.0	0.8	C231J225-6S****
3.3	17.5	12.0	6.0	15.0	0.8	C231J335-6S****
4.7	17.5	13.5	7.5	15.0	0.8	C231J475-6S****
6.8	17.5	14.5	8.5	15.0	0.8	C231J685-6S****
10.0	17.5	19.0	11.0	15.0	0.8	C231J106-6S****
3.3	26.5	16.0	7.0	22.5	0.8	C231J335-9S****
4.7	26.5	16.0	7.0	22.5	0.8	C231J475-9S****
6.8	26.5	16.0	7.0	22.5	0.8	C231J685-9S****
10.0	26.5	17.0	8.5	22.5	0.8	C231J106-9S****
15.0	26.5	20.0	11.0	22.5	0.8	C231J156-9S****
4.7	32.0	18.0	9.0	27.5	0.8	C231J475-BS****
6.8	32.0	18.0	9.0	27.5	0.8	C231J685-BS****
10.0	32.0	18.0	9.0	27.5	0.8	C231J106-BS****
15.0	32.0	18.0	9.0	27.5	0.8	C231J156-BS****
22.0	32.0	22.0	13.0	27.5	0.8	C231J226-BS****
33.0	32.0	24.5	15.0	27.5	0.8	C231J336-BS****
47.0	32.0	30.0	16.0	27.5	0.8	C231J476-BS****

100Vdc (63Vac)						
C <sub>N</sub> (μF)	W ±0.4	H ±0.4	T ±0.4	P ±0.4	d	Part number
0.22	10.5	8.5	3.5	7.5	0.5	C232A224-3S****
0.33	10.5	9.0	4.0	7.5	0.6	C232A334-3S****
0.39	10.5	9.0	4.0	7.5	0.6	C232A394-3S****
0.47	10.5	9.0	4.0	7.5	0.6	C232A474-3S****
0.68	10.5	11.0	5.0	7.5	0.6	C232A684-3S****
1.0	10.5	12.0	6.0	7.5	0.6	C232A105-3S****
0.10	13.0	9.0	4.0	10.0	0.6	C232A104-4S****
0.15	13.0	9.0	4.0	10.0	0.6	C232A154-4S****
0.22	13.0	9.0	4.0	10.0	0.6	C232A224-4S****
0.33	13.0	9.0	4.0	10.0	0.6	C232A334-4S****
0.47	13.0	9.0	4.0	10.0	0.6	C232A474-4S****
0.68	13.0	9.0	4.0	10.0	0.6	C232A684-4S****
1.0	13.0	11.0	5.0	10.0	0.6	C232A105-4S****
1.5	13.0	12.0	6.0	10.0	0.6	C232A155-4S****
0.33	17.5	11.0	5.0	15.0	0.8	C232A334-6S****
0.47	17.5	11.0	5.0	15.0	0.8	C232A474-6S****
0.68	17.5	11.0	5.0	15.0	0.8	C232A684-6S****
1.0	17.5	11.0	5.0	15.0	0.8	C232A105-6S****
1.5	17.5	12.0	6.0	15.0	0.8	C232A155-6S****
1.8	17.5	12.0	6.0	15.0	0.8	C232A185-6S****
2.2	17.5	12.0	6.0	15.0	0.8	C232A225-6S****
3.3	17.5	13.5	7.5	15.0	0.8	C232A335-6S****
4.7	17.5	14.5	8.5	15.0	0.8	C232A475-6S****
1.5	26.5	15.0	6.0	22.5	0.8	C232A155-9S****
1.8	26.5	15.0	6.0	22.5	0.8	C232A185-9S****
2.2	26.5	15.0	6.0	22.5	0.8	C232A225-9S****
3.3	26.5	15.0	6.0	22.5	0.8	C232A335-9S****
4.7	26.5	16.0	7.0	22.5	0.8	C232A475-9S****
6.8	26.5	18.5	10.0	22.5	0.8	C232A685-9S****
10.0	26.5	22.0	12.0	22.5	0.8	C232A106-9S****
4.7	32.0	18.0	9.0	27.5	0.8	C232A475-BS****
6.8	32.0	18.0	9.0	27.5	0.8	C232A685-BS****
10.0	32.0	20.0	11.0	27.5	0.8	C232A106-BS****
15.0	32.0	20.0	11.0	27.5	0.8	C232A156-BS****
22.0	32.0	25.0	13.0	27.5	0.8	C232A226-BS****
33.0	32.0	30.0	16.0	27.5	0.8	C232A336-BS****

Note: 1. “-”=capacitance tolerance code, M=±20%,K=±10%,J=±5%  
2. “\*\*\*\*”=lead form and packing code (refer to table 1).

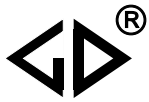

■ **Dimensions (mm)**

Pattern II (Reduced sizes)

250Vdc (160Vac)						
C <sub>N</sub> (μF)	W ±0.4	H ±0.4	T ±0.4	P ±0.4	d	Part number
0.068	10.5	8.5	3.5	7.5	0.5	C232E683-3S****
0.10	10.5	8.5	3.5	7.5	0.5	C232E104-3S****
0.15	10.5	9.0	4.0	7.5	0.6	C232E154-3S****
0.18	10.5	11.0	5.0	7.5	0.6	C232E184-3S****
0.22	10.5	11.0	5.0	7.5	0.6	C232E224-3S****
0.27	10.5	12.0	6.0	7.5	0.6	C232E274-3S****
0.33	10.5	12.0	6.0	7.5	0.6	C232E334-3S****
0.033	13.0	9.0	4.0	10.0	0.6	C232E333-4S****
0.047	13.0	9.0	4.0	10.0	0.6	C232E473-4S****
0.068	13.0	9.0	4.0	10.0	0.6	C232E683-4S****
0.10	13.0	9.0	4.0	10.0	0.6	C232E104-4S****
0.15	13.0	9.0	4.0	10.0	0.6	C232E154-4S****
0.22	13.0	11.0	5.0	10.0	0.6	C232E224-4S****
0.33	13.0	11.0	5.0	10.0	0.6	C232E334-4S****
0.39	13.0	12.0	6.0	10.0	0.6	C232E394-4S****
0.47	13.0	12.0	6.0	10.0	0.6	C232E474-4S****
0.10	17.5	11.0	5.0	15.0	0.8	C232E104-6S****
0.15	17.5	11.0	5.0	15.0	0.8	C232E154-6S****
0.22	17.5	11.0	5.0	15.0	0.8	C232E224-6S****
0.33	17.5	11.0	5.0	15.0	0.8	C232E334-6S****
0.47	17.5	11.0	5.0	15.0	0.8	C232E474-6S****
0.68	17.5	12.0	6.0	15.0	0.8	C232E684-6S****
1.0	17.5	13.5	7.5	15.0	0.8	C232E105-6S****
1.5	17.5	14.5	8.5	15.0	0.8	C232E155-6S****
0.22	26.5	15.0	6.0	22.5	0.8	C232E224-9S****
0.47	26.5	15.0	6.0	22.5	0.8	C232E474-9S****
0.68	26.5	15.0	6.0	22.5	0.8	C232E684-9S****
1.0	26.5	15.0	6.0	22.5	0.8	C232E105-9S****
1.5	26.5	16.0	7.0	22.5	0.8	C232E155-9S****
1.8	26.5	16.0	7.0	22.5	0.8	C232E185-9S****
2.2	26.5	17.0	8.5	22.5	0.8	C232E225-9S****
3.3	26.5	20.0	11.0	22.5	0.8	C232E335-9S****
1.5	32.0	18.0	9.0	27.5	0.8	C232E155-BS****
1.8	32.0	18.0	9.0	27.5	0.8	C232E185-BS****
2.2	32.0	18.0	9.0	27.5	0.8	C232E225-BS****
3.3	32.0	18.0	9.0	27.5	0.8	C232E335-BS****
4.7	32.0	20.0	11.0	27.5	0.8	C232E475-BS****
6.8	32.0	22.0	13.0	27.5	0.8	C232E685-BS****
10.0	32.0	24.5	15.0	27.5	0.8	C232E106-BS****

400Vdc (200Vac)						
C <sub>N</sub> (μF)	W ±0.4	H ±0.4	T ±0.4	P ±0.4	d	Part number
0.022	10.5	8.5	3.5	7.5	0.5	C232G223-3S****
0.033	10.5	8.5	3.5	7.5	0.5	C232G333-3S****
0.047	10.5	9.0	4.0	7.5	0.6	C232G473-3S****
0.068	10.5	11.0	5.0	7.5	0.6	C232G683-3S****
0.082	10.5	12.0	6.0	7.5	0.6	C232G823-3S****
0.10	10.5	12.0	6.0	7.5	0.6	C232G104-3S****
0.010	13.0	9.0	4.0	10.0	0.6	C232G103-4S****
0.015	13.0	9.0	4.0	10.0	0.6	C232G153-4S****
0.022	13.0	9.0	4.0	10.0	0.6	C232G223-4S****
0.033	13.0	9.0	4.0	10.0	0.6	C232G333-4S****
0.047	13.0	9.0	4.0	10.0	0.6	C232G473-4S****
0.056	13.0	9.0	4.0	10.0	0.6	C232G563-4S****
0.068	13.0	11.0	5.0	10.0	0.6	C232G683-4S****
0.10	13.0	11.0	5.0	10.0	0.6	C232G104-4S****
0.15	13.0	12.0	6.0	10.0	0.6	C232G154-4S****
0.047	17.5	11.0	5.0	15.0	0.8	C232G473-6S****
0.068	17.5	11.0	5.0	15.0	0.8	C232G683-6S****
0.10	17.5	11.0	5.0	15.0	0.8	C232G104-6S****
0.15	17.5	11.0	5.0	15.0	0.8	C232G154-6S****
0.22	17.5	12.0	6.0	15.0	0.8	C232G224-6S****
0.33	17.5	13.5	7.5	15.0	0.8	C232G334-6S****
0.47	17.5	14.5	8.5	15.0	0.8	C232G474-6S****
0.56	17.5	16.0	10.0	15.0	0.8	C232G564-6S****
0.68	17.5	16.0	10.0	15.0	0.8	C232G684-6S****
0.22	26.5	15.0	6.0	22.5	0.8	C232G224-9S****
0.33	26.5	15.0	6.0	22.5	0.8	C232G334-9S****
0.47	26.5	15.0	6.0	22.5	0.8	C232G474-9S****
0.68	26.5	16.0	7.0	22.5	0.8	C232G684-9S****
1.0	26.5	18.50	10.0	22.5	0.8	C232G105-9S****
1.5	26.5	22.0	12.0	22.5	0.8	C232G155-9S****
0.68	32.0	18.0	9.0	27.5	0.8	C232G684-BS****
1.0	32.0	18.0	9.0	27.5	0.8	C232G105-BS****
1.5	32.0	20.0	11.0	27.5	0.8	C232G155-BS****
1.8	32.0	20.0	11.0	27.5	0.8	C232G185-BS****
2.2	32.0	22.0	13.0	27.5	0.8	C232G225-BS****
3.3	32.0	24.5	15.0	27.5	0.8	C232G335-BS****
4.7	32.0	30.0	16.0	27.5	0.8	C232G475-BS****
6.8	32.0	33.0	18.0	27.5	0.8	C232G685-BS****

Note: 1. “-”=capacitance tolerance code, M=±20%,K=±10%,J=±5%  
2. “\*\*\*\*”=lead form and packing code (refer to table 1).



■ **Dimensions (mm)**

Pattern II (Reduced sizes)

630Vdc (220Vac) <sup>@</sup>						
C <sub>N</sub> (μF)	W ±0.4	H ±0.4	T ±0.4	P ±0.4	d	Part number
0.0022	10.5	8.5	3.5	7.5	0.5	C232J222-3S****
0.0047	10.5	8.5	3.5	7.5	0.5	C232J472-3S****
0.0068	10.5	8.5	3.5	7.5	0.5	C232J682-3S****
0.010	10.5	8.5	3.5	7.5	0.5	C232J103-3S****
0.015	10.5	9.0	4.0	7.5	0.6	C232J153-3S****
0.022	10.5	11.0	5.0	7.5	0.6	C232J223-3S****
0.033	10.5	12.0	6.0	7.5	0.6	C232J333-3S****
0.047	10.5	12.0	6.0	7.5	0.6	C232J473-3S****
0.0047	13.0	9.0	4.0	10.0	0.6	C232J472-4S****
0.0068	13.0	9.0	4.0	10.0	0.6	C232J682-4S****
0.010	13.0	9.0	4.0	10.0	0.6	C232J103-4S****
0.015	13.0	9.0	4.0	10.0	0.6	C232J153-4S****
0.022	13.0	9.0	4.0	10.0	0.6	C232J223-4S****
0.033	13.0	11.0	5.0	10.0	0.6	C232J333-4S****
0.047	13.0	11.0	5.0	10.0	0.6	C232J473-4S****
0.068	13.0	12.0	6.0	10.0	0.6	C232J683-4S****
0.033	17.5	11.0	5.0	15.0	0.8	C232J333-6S****
0.047	17.5	11.0	5.0	15.0	0.8	C232J473-6S****
0.068	17.5	11.0	5.0	15.0	0.8	C232J683-6S****
0.10	17.5	12.0	6.0	15.0	0.8	C232J104-6S****
0.15	17.5	13.5	7.5	15.0	0.8	C232J154-6S****
0.22	17.5	16.0	10.0	15.0	0.8	C232J224-6S****
0.33	17.5	19.0	11.0	15.0	0.8	C232J334-6S****
0.10	26.5	15.0	6.0	22.5	0.8	C232J104-9S****
0.15	26.5	15.0	6.0	22.5	0.8	C232J154-9S****
0.22	26.5	16.0	7.0	22.5	0.8	C232J224-9S****
0.33	26.5	16.0	7.0	22.5	0.8	C232J334-9S****
0.47	26.5	17.0	8.5	22.5	0.8	C232J474-9S****
0.68	26.5	22.0	12.0	22.5	0.8	C232J684-9S****
0.33	32.0	18.0	9.0	27.5	0.8	C232J334-BS****
0.47	32.0	18.0	9.0	27.5	0.8	C232J474-BS****
0.68	32.0	20.0	11.0	27.5	0.8	C232J684-BS****
1.0	32.0	20.0	11.0	27.5	0.8	C232J105-BS****

1 000Vdc (300Vac)						
C <sub>N</sub> (μF)	W ±0.4	H ±0.4	T ±0.4	P ±0.4	d	Part number
0.0010	10.5	8.5	3.5	7.5	0.5	C233A102-3S****
0.0015	10.5	8.5	3.5	7.5	0.5	C233A152-3S****
0.0022	10.5	8.5	3.5	7.5	0.5	C233A222-3S****
0.0033	10.5	8.5	3.5	7.5	0.5	C233A332-3S****
0.0047	10.5	8.5	3.5	7.5	0.5	C233A472-3S****
0.0068	10.5	9.0	4.0	7.5	0.6	C233A682-3S****
0.010	10.5	11.0	5.0	7.5	0.6	C233A103-3S****
0.015	10.5	12.0	6.0	7.5	0.6	C233A153-3S****
0.0010	13.0	9.0	4.0	10.0	0.6	C233A102-4S****
0.0015	13.0	9.0	4.0	10.0	0.6	C233A152-4S****
0.0022	13.0	9.0	4.0	10.0	0.6	C233A222-4S****
0.0033	13.0	9.0	4.0	10.0	0.6	C233A332-4S****
0.0047	13.0	9.0	4.0	10.0	0.6	C233A472-4S****
0.0056	13.0	9.0	4.0	10.0	0.6	C233A562-4S****
0.0068	13.0	9.0	4.0	10.0	0.6	C233A682-4S****
0.010	13.0	9.0	4.0	10.0	0.6	C233A103-4S****
0.015	13.0	11.0	5.0	10.0	0.6	C233A153-4S****
0.022	13.0	11.0	5.0	10.0	0.6	C233A223-4S****
0.010	17.5	11.0	5.0	15.0	0.8	C233A103-6S****
0.015	17.5	11.0	5.0	15.0	0.8	C233A153-6S****
0.022	17.5	11.0	5.0	15.0	0.8	C233A223-6S****
0.033	17.5	12.0	6.0	15.0	0.8	C233A333-6S****
0.047	17.5	12.0	6.0	15.0	0.8	C233A473-6S****
0.068	17.5	13.5	7.5	15.0	0.8	C233A683-6S****
0.10	17.5	14.5	8.5	15.0	0.8	C233A104-6S****
0.033	26.5	15.0	6.0	22.5	0.8	C233A333-9S****
0.047	26.5	15.0	6.0	22.5	0.8	C233A473-9S****
0.068	26.5	15.0	6.0	22.5	0.8	C233A683-9S****
0.10	26.5	15.0	6.0	22.5	0.8	C233A104-9S****
0.15	26.5	16.0	7.0	22.5	0.8	C233A154-9S****
0.22	26.5	17.0	8.5	22.5	0.8	C233A224-9S****
0.33	26.5	20.0	11.0	22.5	0.8	C233A334-9S****
0.15	32.0	18.0	9.0	27.5	0.8	C233A154-BS****
0.22	32.0	18.0	9.0	27.5	0.8	C233A224-BS****
0.33	32.0	20.0	11.0	27.5	0.8	C233A334-BS****
0.47	32.0	20.0	11.0	27.5	0.8	C233A474-BS****
0.68	32.0	28.0	14.0	27.5	0.8	C233A684-BS****
1.0	32.0	30.0	16.0	27.5	0.8	C233A105-BS****
1.5	32.0	37.0	22.0	27.5	0.8	C233A155-BS****

- Note: 1. “-”=capacitance tolerance code, M=±20%,K=±10%,J=±5%  
 2. “\*\*\*\*”=lead form and packing code (refer to table 1).  
 3. “@” Not suitable for across-the-line applications. Pls refer to the Interference Suppression Capacitors.

## ■ MAX. VOLTAGE(Vr.m.s) VERSUS FREQUENCY

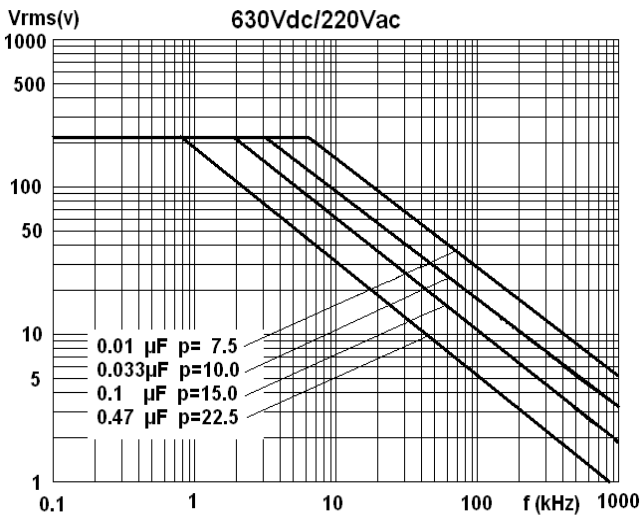
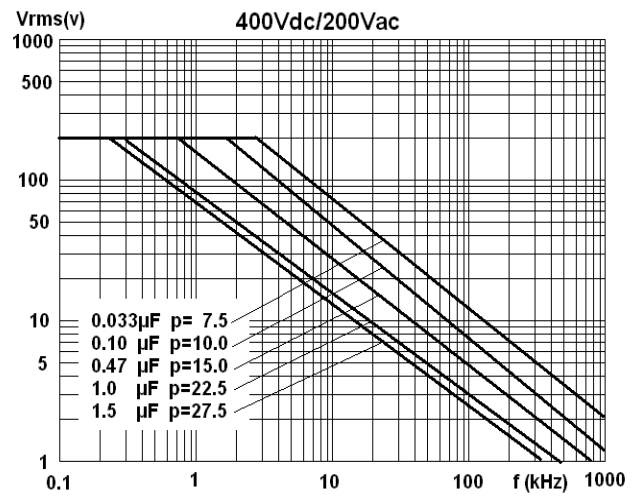
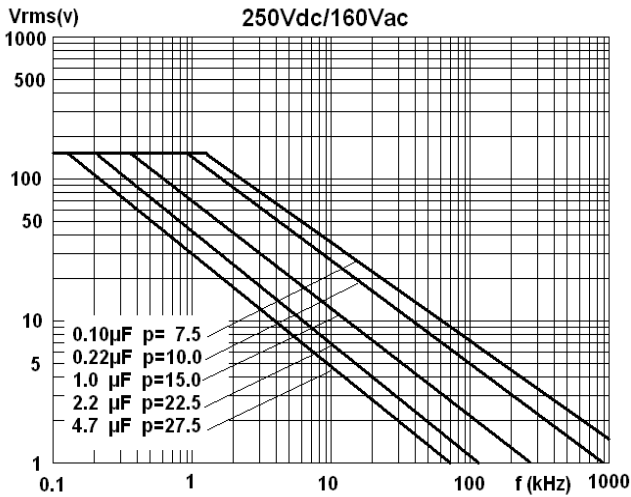
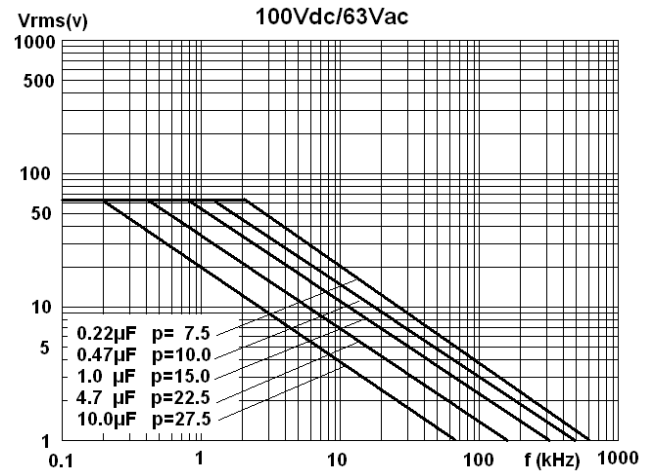
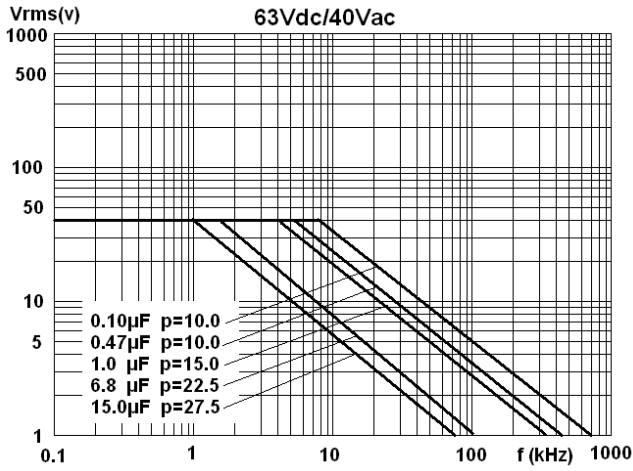

Note: sinusoidal wave-form, environment temperature  $\leq 85^{\circ}\text{C}$ , internal temperature rise  $\Delta T = 15^{\circ}\text{C}$ , p (pitch) in mm..



### ■ Test Method And Performance

No.	Item	Performance	Test method (GB 7332(IEC 60384-2))
1	Solderability	Good quality of tinning	Solder temperature:245°C±5°C Immersion time: 2.0s±0.5s
2	Initial measurement	Capacitance, Tgδ	
	Terminal strength (straight lead)	There shall be no visible damage	Tension Ua1: Pull: φd=0.5mm,5N φd≥0.6mm, 10N Bend Ub: The pull of bend: φd=0.5mm, 2.5N φd≥0.6mm, 5N The terminals shall be bent 2 times in each direction.
	Resistance to solder heat	There shall be no visible damage, legible marking	Solder temperature:260°C±5°C Immersion time: 10s±1s
	Final measurement	ΔC/C ≤±2%(relative to the initial value) Increase of tgδ: ≤0.003 (C≤1.0μF) ≤0.002 (C>1.0μF)	
3	Initial measurement	Capacitance, Tgδ	
	Rapid change of temperature	There shall be no evidence of deterioration.	θ <sub>A</sub> =-55°C, θ <sub>B</sub> =+105°C 5 cycles Duration: t=30min
	Vibration(straight lead)	There shall be no evidence of deterioration.	Amplitude 0.75mm or acceleration 98m/s <sup>2</sup> (whichever is the smaller severity), f: 10Hz to 500Hz.Three directions, 2h for each direction, total 6h.
	Bump(straight lead)	There shall be no evidence of deterioration.	4 000 times, Acceleration: 390m/s <sup>2</sup> ,Pulse duration, 6ms
	Final measurement	ΔC/C ≤±5%(relative to the initial value) Increase of tgδ: ≤0.003 (C≤1.0μF) ≤0.002 (C>1.0μF) IR: ≥ 50% of the rated value	
4	climate sequence	Initial measurement	Capacitance, Tgδ
		Dry heat	+105°C, 16h
		Damp heat, Cyclic	Test Db, Severity: b, the first cycle
		Cold	-55°C, 2h
		Low air pressure	There shall be no permanent breakdown,flashover or other harmful deformation when applying U <sub>R</sub> at the last 1 minute. 15°C~ 35°C, 8.5kPa, 1h,
		Damp heat, cyclic other	Test Db, Severity b, the other cycles, Applying U <sub>R</sub> for 1 minute after the test finished.

No.	Item		Performance	Test method (GB 7332(IEC 60384-2))
4	climate sequence (continue)	Final measurement	<p>There shall be no evidence of deterioration and the marking shall be legible.</p> <p><math>\Delta C/C \leq \pm 5\%</math> (relative to the initial value)</p> <p>Increase of <math>\text{tg}\delta</math>:</p> <p><math>\leq 0.005</math> (<math>C \leq 1.0\mu\text{F}</math>)</p> <p><math>\leq 0.003</math> (<math>C &gt; 1.0\mu\text{F}</math>)</p> <p>IR: <math>\geq 50\%</math> of the rated value</p>	
5	Damp heat steady state		<p>There shall be no evidence of deterioration and the marking shall be legible.</p> <p><math>\Delta C/C \leq \pm 5\%</math> (relative to the initial value)</p> <p>Increase of <math>\text{tg}\delta \leq 0.005</math></p> <p>IR: <math>\geq 50\%</math> of the rated value</p>	<p>Temperature: <math>40^\circ\text{C} \pm 2^\circ\text{C}</math></p> <p>Humidity: <math>93 \pm 2\%</math> RH</p> <p>Duration: 56days</p>
6	Endurance		<p>There shall be no evidence of deterioration and the marking shall be legible.</p> <p><math>\Delta C/C \leq \pm 5\%</math> (relative to the initial value)</p> <p>Increase of <math>\text{tg}\delta</math>:</p> <p><math>\leq 0.003</math> (<math>C \leq 1.0\mu\text{F}</math>)</p> <p><math>\leq 0.002</math> (<math>C &gt; 1.0\mu\text{F}</math>)</p> <p>IR: <math>\geq 50\%</math> of the rated value</p>	<p>Temperature: <math>+85^\circ\text{C}/+100^\circ\text{C}</math></p> <p>Voltage: <math>1.25 \times U_R / 1.25 \times U_c</math> (<math>U_c = 0.8U_R</math>)</p> <p>Duration: 2 000h</p>
7	Temperature characteristic		<p>Measuring capacitance at test point b, d, f:</p> <p>Characteristic at lower category temperature <math>-55^\circ\text{C}</math>:</p> <p><math>-10\% \leq (C_b - C_d) / C_d \leq 0\%</math></p> <p>Characteristic at upper category temperature <math>+100^\circ\text{C}</math>:</p> <p><math>0\% \leq (C_f - C_d) / C_d \leq +10\%</math></p> <p>I.R. (test at point f):</p> <p><math>U_R \leq 100\text{V}</math>: <math>\geq 75 \text{ M}\Omega</math> (<math>C \leq 0.33\mu\text{F}</math>)</p> <p><math>\geq 25\text{s}</math> (<math>C &gt; 0.33\mu\text{F}</math>)</p> <p><math>U_R &gt; 100\text{V}</math>: <math>\geq 150 \text{ M}\Omega</math> (<math>C \leq 0.33\mu\text{F}</math>)</p> <p><math>\geq 50\text{s}</math> (<math>C &gt; 0.33\mu\text{F}</math>)</p>	<p>Static method: The Capacitors should be kept at the following temperature in turn:</p> <p>a(<math>20 \pm 2</math>) <math>^\circ\text{C}</math>, b(<math>-55 \pm 3</math>) <math>^\circ\text{C}</math>, d(<math>20 \pm 2</math>) <math>^\circ\text{C}</math>, f(<math>100 \pm 2</math>) <math>^\circ\text{C}</math>, g(<math>20 \pm 2</math>) <math>^\circ\text{C}</math></p>
8	Charging and discharging		<p><math>\Delta C/C \leq \pm 5\%</math> (relative to the initial value)</p> <p>Increase of <math>\text{tg}\delta</math>:</p> <p><math>\leq 0.003</math> (<math>C \leq 1.0\mu\text{F}</math>)</p> <p><math>\leq 0.002</math> (<math>C &gt; 1.0\mu\text{F}</math>)</p> <p>IR: <math>\geq 50\%</math> of the rated value</p>	<p>Times: 10 000</p> <p>Duration of charging: 0.5s</p> <p>Duration of discharging: 0.5s</p> <p>Charging voltage: rated voltage</p> <p>Charging resistance: <math>220/C_N(\Omega)</math></p> <p>Discharging resistance:</p> <p><math>R = 10/C_N(\Omega)</math> or <math>20\Omega</math> (whichever is the greater)</p> <p><math>C_N</math>: rated capacitance (<math>\mu\text{F}</math>)</p>

- **Marking:**  
For example:

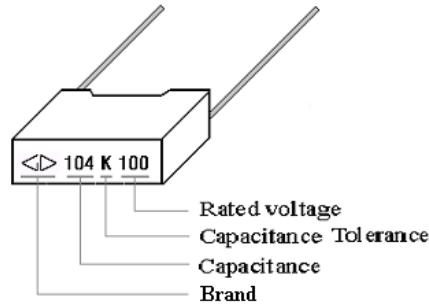

## ■ Taping specification for box-type capacitors

### ▲ Outline Drawing

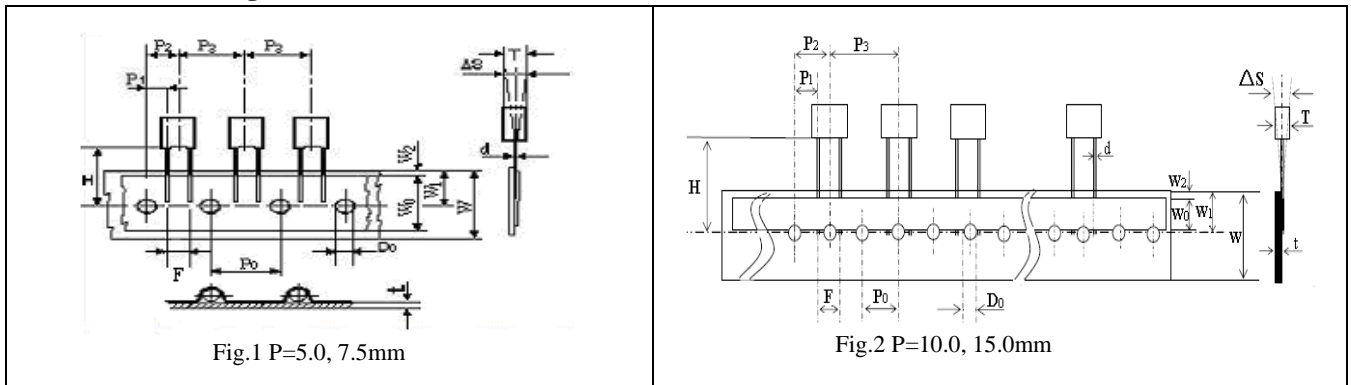

### ▲ Taping Dimensions(mm)

Technology index title	Code	Dimensions				Tolerance
		P=5.0	P=7.5	P=10.0	P=15.0	
Taping type	—	Fig 1	Fig 1	Fig2	Fig 2	—
Part number Digit12-15	Ammo-pack	A201	A301	A405	A605	
Taping pitch	P <sub>3</sub>	12.7	12.7	25.4	25.4	±1.0
Feed hole pitch	P <sub>0</sub>	12.7	12.7	12.7	12.7	±0.3
Center of wire	P <sub>1</sub>	3.85	2.6	7.7	5.2	±0.7
Center of body	P <sub>2</sub>	6.35	6.35	12.7	12.7	±1.3
Pitch of taping wire	F**	5.0	7.5	10.0	15.0	+0.6 -0.1
Component alignment	△S	0	0	0	0	±2.0
Height of component from tape center	H***	18.5	18.5	18.5	18.5	±0.5
Carrier tape width	W	18.0	18.0	18.0	18.0	+1.0 -0.5
Hold down tape width	W <sub>0</sub>	6min	10min	10min	10min	—
Hole position	W <sub>1</sub>	9.0	9.0	9.0	9.0	±0.5
Hold down tape position	W <sub>2</sub>	3max	3max	3max	3max	—
Feed hole dia.	D <sub>0</sub>	4.0	4.0	4.0	4.0	±0.2
Tape thickness	t	0.7	0.7	0.7	0.7	±0.2

**Note:** \* P<sub>0</sub>=15mm is also available;  
 \*\*F can be other lead spacing;  
 \*\*\*H=16.5mm is available;

■ Packing box sizes(mm)(example)

1. Out packing box for bulk

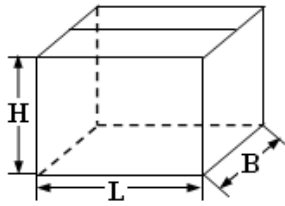

L:375±5  
B:375±5  
H:265±5

2. Inner packing box for bulk

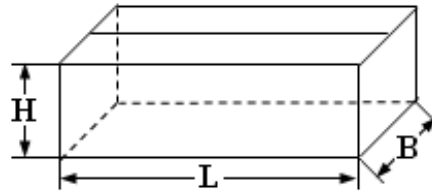

L:355±3  
B:175±3  
H:118±3

3. Box sizes for Ammo-pack

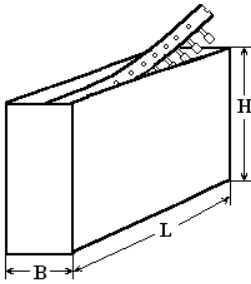

L:350±3  
B:50±3  
H:260±3