



THINKING ELECTRONIC INDUSTRIAL CO., LTD.

HEAD OFFICE: 12F, No.93, Dashun 1st Rd., Zuoying Dist., Kaohsiung, Taiwan
TEL: 886-7-5577660 FAX: 886-7-5570560

MANUFACTURING SITE

- KAOHSIUNG FACTORY 1: No. 51, Kaifa Rd., N.E.P.Z, Kaohsiung City 81170, Taiwan
TEL: 886-7-9616668 FAX: 886-7-9616698
- KAOHSIUNG FACTORY 2: No. 2-2, Xinjian S. Rd., N.E.P.Z., Kaohsiung City 81170, Taiwan
TEL: 886-7-9630001 FAX: 886-7-3635113
- CHANGZHOU FACTORY: No.6 Longmen Rd., Wujin High & New-Tech Industrial
Development Zone, Changzhou, Jiangsu, China 213161
TEL: 86-519-86578999 FAX: 86-519-86558643
- DONG GUAN FACTORY: No.45, East Rd., Sha-Tao Dist., Chang-An Town,
Dongguan City, Guangdong, China 523863
TEL: 86-769-85542016 FAX: 86-769-85546890
- YICHANG FACTORY: No. 283 Xiaoting Avenue, Xiaoting Dist., Yichang
City 443007, Hubei, China
TEL: 86-717-6510010 FAX: 86-717-6511430



SPECIFICATION FOR APPROVAL

CUSTOMER _____

CERTIFIED
MODEL/TYPE

TVR07330-M

PART NO.

TVR07330KLRBQ01M (RoHS+HF)

APPLICATION _____

CUSTOMER P/N _____

ISSUE DATE

Apr.07.2022

REV. NO. _____

REV. DATE _____

FOR CUSTOMER APPROVAL	CHECKED BY
	Yuan Yuan
	APPROVED BY
	Huaifang Zhang





REVISED RECORD SHEET

REV. NO	REV. DATE	REVISED CONTENT



INDEX	Page
■ Part Number Code	1
■ Structure and Dimensions	2
■ Electrical Characteristics	2
■ Reliability	3 ~ 4
■ Soldering Recommendation	5
■ Power Derating Curve	6
■ RoHS Compliant Declaration	6
■ Warehouse Storage Conditions of Products	6
■ Taping and Dimensions	7
■ Packaging	8
■ Safety Approvals	9
■ Certificates	9
■ AEC -Q200	9
■ Test Reprot	9
■ Max. Surge Current Derating Curves	10
■ Max. Leakage Current and Max. Clamping Voltage Curve	11

Part Number Code

Example :

TVR **07** **330** **K** **L** **RB** **Q01** **M**
 (1) (2) (3) (4) (5) (6) (7) (8)

No.	Item	Digit	Specification
(1)	Product Type	TVR	Thinking varistor TVR type
(2)	Body Size	07	φ 07 mm
(3)	Varistor Voltage	330	33x 10 ⁰ V = 33V (V _{1mA})
(4)	Tolerance of V _{1mA}	K	Tolerance of V _{1mA}
(5)	Appearance	L	Straight Lead , Silicon Coating
(6)	Packaging	R	original tapping(hole pitch: 12.7mm)
		B	box
(7)	Optional Suffix	Q01	1.RoHS+HF varistor products for Automotive 2. Lmin:34mm
(8)	Type Code	M	Automobile application

Structure and Dimensions

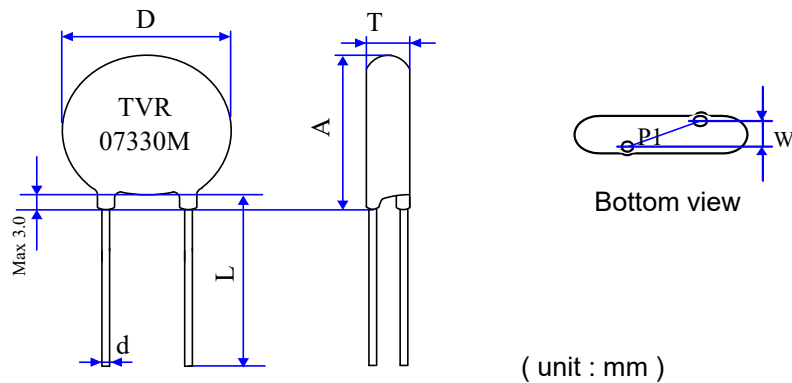

Body Size	Dmax	P 1	d	A max.	L min.	Tmax	W
φ 07	9.6	5.0±1	0.6±0.02	11.0	34	3.6	1.7±1

Electrical Characteristics (Ambient Ta=25 °C)

Part No.	Varistor Voltage (@ 1mA DC)	Max. Continuous Voltage	Max. Clamping Voltage (8/20μS)		Max. Surge Current (8/20μS)	Load dump (ISO7637 pulse 5)
	V _{1mA} (V)		V _{DC} (V)	V _p (V)		
TVR07330KLRBQ01M	30~36	26	65	2.5	500	12

Part No.	Jump start (5 minutes)	Rated Power	Impulse Response Time	Max. Energy (10/1000μS)	Operating Temperature Range	Storage temperature Range	Applications
	VDC (V)						P (W)
TVR07330KLRBQ01M	36	0.02	<50	2	-40 ~ +125	-40 ~ +150	Self-declared

The mechanical force acted on the wire lead may cause cracks and chips of coating ,but which does not affect the performance of the component

Reliability

Tests of Leaded Varistor are based on AEC-Q200 REV D.

Item	Standard	Test conditions / Methods	Specifications
High Temperature Exposure (Storage)	MIL-STD-202 Method 108	Test temp.: 150 +3/-0°C Duration: 1000 h Unpowered Measurement at 24±2 hours after test conclusion.	No visible damage , $\Delta V_{1mA}/V_{1mA}$ ≤ 10% , $\Delta V_{clamp}/V_{clamp}$ ≤ 10%
Temperature Cycling	JESD22 Method JA-104	Lower test temp.: -40(+0/-10°C) Upper test temp.: 125 (+15/-0°C) Dwell Time : 30 min transfer time : ≤ 1min	No visible damage , $\Delta V_{1mA}/V_{1mA}$ ≤ 10% , $\Delta V_{clamp}/V_{clamp}$ ≤ 10%
Biased Humidity	MIL-STD-202 Method 103	Test temp.:85°C Rel. humidity of air: 85% Duration: 1000 h	No visible damage , $\Delta V_{1mA}/V_{1mA}$ ≤ 10% , $\Delta V_{clamp}/V_{clamp}$ ≤ 10%
Operational Life	MIL-STD-202 Method 108	Test temp.: 125 +3/-0°C Duration: 1000 h Test Power: Bias at 85%(+5%/-0%)of rated Varistor v	No visible damage , $\Delta V_{1mA}/V_{1mA}$ ≤ 10% , $\Delta V_{clamp}/V_{clamp}$ ≤ 10%
External Visual	MIL-STD-883 Method 2009	Visual Inspection	No visible damage
Physical Dimension	JESD22 Method JB-100	Verify physical dimensions to the applicable device specification.	Within the specified values
Terminal Strength	MIL-STD-202 Method 211	1. Pull test (2.27 kg), 2. Wire-lead bend test (227 g) Duration of the applied forces: 10 ±1sec	No visible damage , $\Delta V_{1mA}/V_{1mA}$ ≤ 10% , $\Delta V_{clamp}/V_{clamp}$ ≤ 10%
Resistance to Solvents	MIL-STD-202 Method 215	Note: Add Aqueous wash chemical - OKEM Clean or equivalent. Do not use banned solvents.	No visible damage
Mechanical Shock	MIL-STD-202 Method 213	Peak value: 100g's Half sine Waveform Normal duration (D): 6ms In 3 directions perpendicularly intersecting each other (total 18 times)	No visible damage , $\Delta V_{1mA}/V_{1mA}$ ≤ 10% , $\Delta V_{clamp}/V_{clamp}$ ≤ 10%
Vibration	MIL-STD-202 Method 204	Acceleration: 5 g's Sweep time: 20 min Frequency range: 10Hz~2KHz~10Hz	No visible damage , $\Delta V_{1mA}/V_{1mA}$ ≤ 10% , $\Delta V_{clamp}/V_{clamp}$ ≤ 10%
Resistance to Soldering Heat	MIL-STD-202 Method 210	No pre-heat of samples. Temperature : 260 ±5°C, Time : 10 ±1 s Depth : 1.5mm from Solder bath to body of the specimen Immersion and emersion rate : 25mm/s ±6 mm/s Number of heat cycles : 1	No visible damage , $\Delta V_{1mA}/V_{1mA}$ ≤ 10% , $\Delta V_{clamp}/V_{clamp}$ ≤ 10%

Reliability

Tests of Leaded Varistor are based on AEC-Q200 REV D.

Item	Standard	Test conditions / Methods	Specifications
Solderability	J-STD-002	Steam aging 8hr@93±3°C, 235±5°C 5 +0/-0.5sec	95% of termination wetted
Electrical Characterization	Per Spec.	Varistor voltage and clamping voltage	Meet spec.
Load Dump	ISO-7637-2	Test pulses 5a	No visible damage · $\Delta V_{1mA}/V_{1mA}$ ≤ 15%
Vjump	Specification Standard	5 minutes duration , VDC (TVR**180-Q); Vjump = 20 V (TVR**220-Q); Vjump = 25 V (TVR**270-Q); Vjump = 30 V (TVR**330-Q); Vjump = 36 V (TVR**390-Q); Vjump = 42V (TVR**470-Q); Vjump = 50V (TVR**560-Q); Vjump = 59 V (TVR**680-Q); Vjump = 65 V	No visible damage · $\Delta V_{1mA}/V_{1mA}$ ≤ 15% · $\Delta V_{clamp}/V_{clamp}$ ≤ 10%

Soldering Recommendation

Wave Soldering Profile

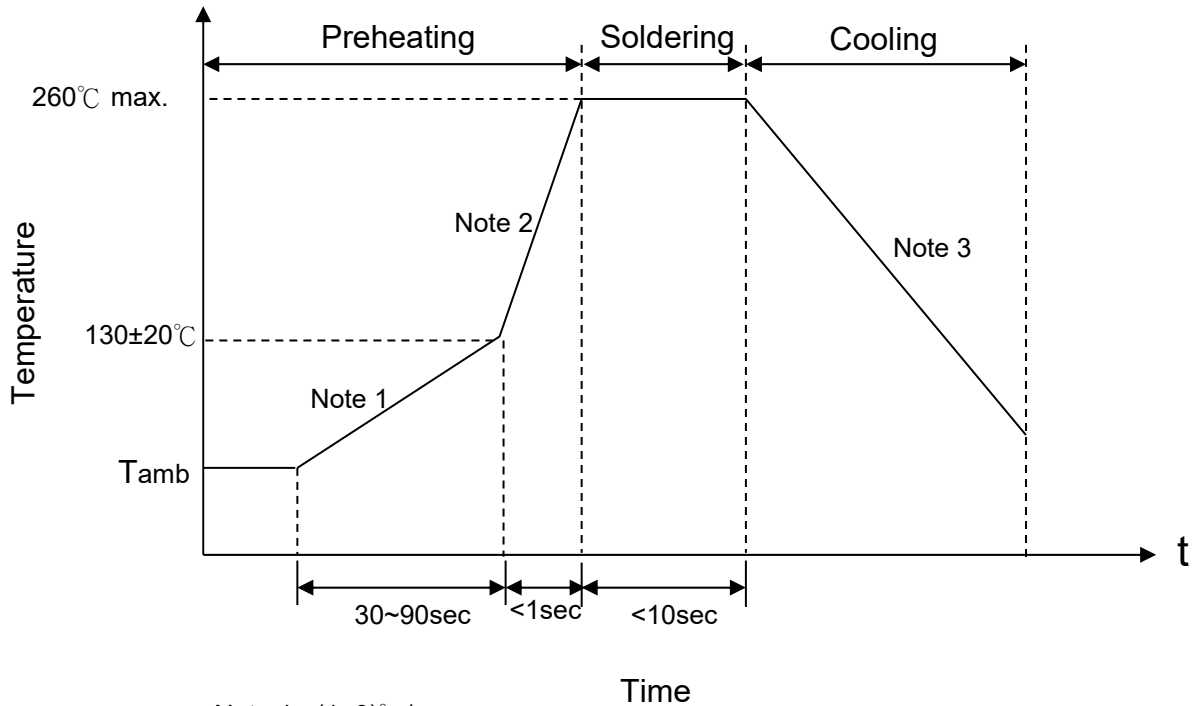

- Note 1 : (1~3)°C/sec
 Note 2 : Approx. 200°C/sec
 Note 3 : 5°C/sec Max

Recommended Reworking Conditions with Soldering Iron

Item	Conditions
Temperature of Soldering Iron-tip	360°C (max.)
Soldering Time	3 sec (max.)
Distance from Varistor	2 mm (min.)

Power Derating Curve

When operating temperature exceeds 125°C, the power, the Max.continuous operation Voltage, the Max.Surge Current and the Max.Energy should be derated as below figure, the derated coefficient is -4%.

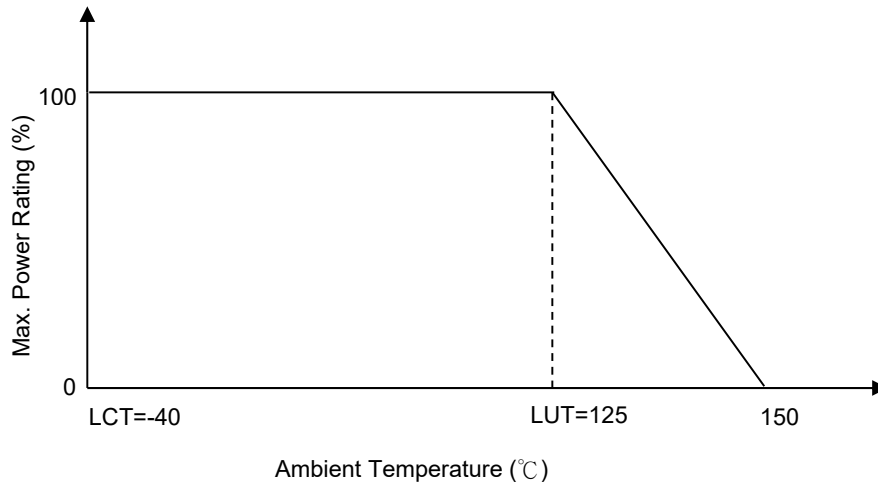

RoHS Compliant Declaration

We hereby declare that the components delivered to your company are compliant with RoHS directive 2015/863/EU.

Warehouse Storage Conditions of Products

(I) Storage Conditions :

- 1.Storage Temperature : -10°C~+40°C
- 2.Relative Humidity : $\leq 75\%RH$
- 3.Keep away from corrosive atmosphere and sunlight.

(II) Period of Storage : 1 year

Taping and Dimensions

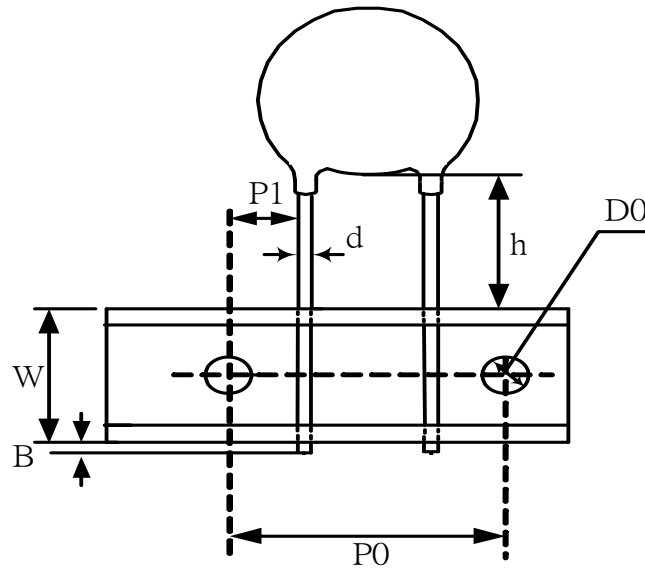

ITEM.	P0	P1	h	W	B	d	D0
Nor.	12.7	3.55	13	18	1	0.6	4
ToL.	±1	±1	±1	±1	max	±0.02	±0.02

Packaging

(1) Inner Box (1200pcs /Box)

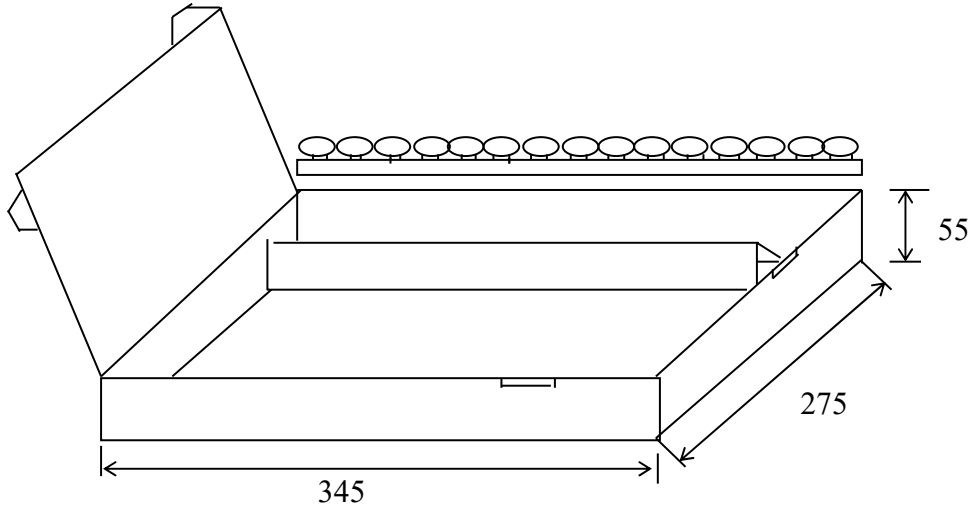

(2) Outer Box (5 Boxes /Carton)

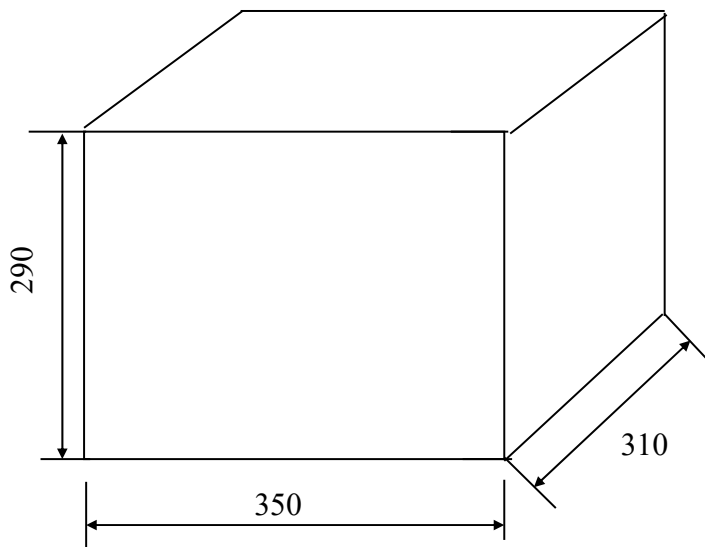

(Unit:mm)

Safety Approvals (Certified Model/Type:TVR07330-M)



* CQC GB/T10193-1997 ` GB/T10194-1997 recognized
(File #CQC15001128788/CQC15001128790)

AEC-Q200

We hereby declare that the components delivered to your company are compliant with AEC-Q200 Rev.D

Certificates

- (1) IATF 16949 certificate
- (2) ISO 9001 certificate

Test Report

- (1) RoHS test report
- (2) Halogen-free test report



Max. Surge Current Derating Curves

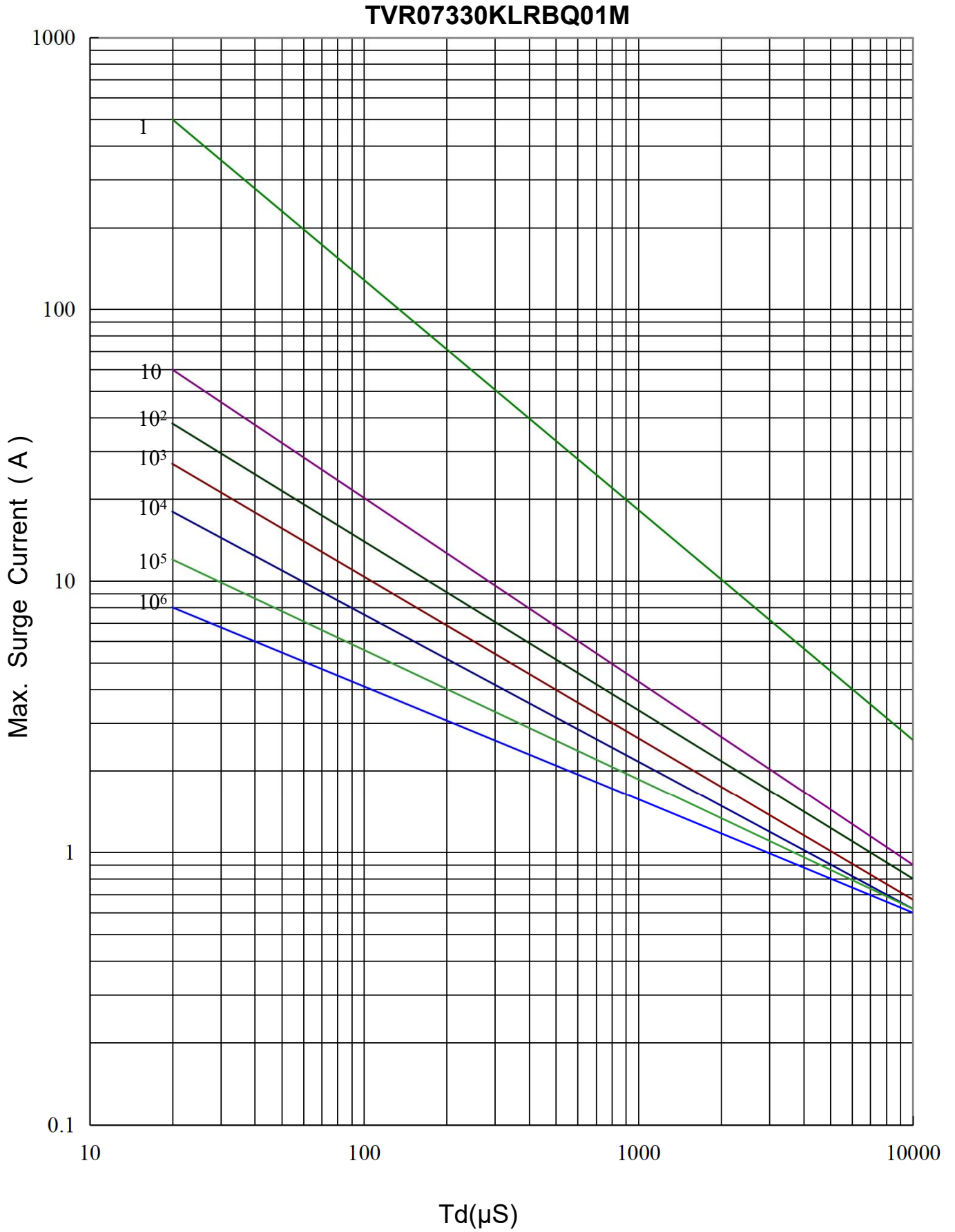



Max. Leakage Current and Max. Clamping Voltage Curves

