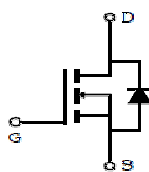


## Features

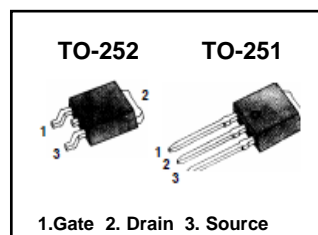
- Lead free and Green Device Available
- Low Rds-on to Minimize Conductive Loss
- High avalanche Current



<b>V<sub>DSS</sub></b>	<b>30V</b>
<b>R<sub>DS(on)</sub> V<sub>GS</sub>=10V typ.</b>	<b>3.1mΩ</b>
	<b>4.1mΩ</b>
<b>R<sub>DS(on)</sub> V<sub>GS</sub>=4.5V typ. max.</b>	<b>4.3mΩ</b>
	<b>7mΩ</b>
<b>I<sub>D</sub> @ V<sub>GS</sub>=10V (Silicon limited)</b>	<b>100A</b>
<b>I<sub>D</sub> @ V<sub>GS</sub>=10V (Package limited)</b>	<b>80A</b>

## Application

- Load Switch
- SPMS



## Absolute Maximum Ratings (T<sub>A</sub>=25°C unless otherwise noted)

Symbol	Param	Maximum	Unit	
V <sub>DSS</sub>	Drain-to-Source Voltage	30	V	
V <sub>GSS</sub>	Gate-to-Source Voltage	±20	V	
I <sub>D</sub> V <sub>GS</sub> =10V	Continuous Drain Current	T <sub>C</sub> =25°C (Silicon limited)	100	A
		T <sub>C</sub> =100°C (Silicon limited)	80	
I <sub>D</sub> V <sub>GS</sub> =4.5V		T <sub>C</sub> =25°C (Package limited)	70	
		T <sub>C</sub> =25°C (Silicon limited)	100	
		T <sub>C</sub> =100°C (Silicon limited)	65	
		T <sub>C</sub> =25°C (Package limited)	70	
I <sub>DP</sub>	Pulsed Drain Current	T <sub>C</sub> =25°C	-	A
I <sub>AS</sub>	Avalanche Current (L=0.1mH)		23	A
E <sub>AS</sub>	Avalanche Energy (L=0.1mH)		26	mJ
P <sub>D</sub>	Maximum Power Dissipation	T <sub>C</sub> =25°C	71	W
		T <sub>C</sub> =100°C	35	
T <sub>J</sub> , T <sub>STG</sub>	Junction & Storage Temperature Range		-55~175	°C

## Thermal Characteristics

Symbol	Parameter	Max.	Unit
R <sub>thJC</sub>	Thermal resistance, junction to case	2.1	°C/W
R <sub>thJA</sub>	Thermal resistance, junction to ambient	106	°C/W

**Electrical Characteristics** (TA=25°C unless otherwise noted)

Symbol	Parameter	Test Conditions	Min.	Typ	Max.	Unit
<b>Static Characteristics</b>						
$BV_{DSS}$	Drain-Source Breakdown Voltage	$V_{GS}=0V, I_D=250\mu A$	30	—	—	V
$I_{DSS}$	Zero Gate Voltage Drain Current	$V_{DS}=30V, V_{GS}=0V$	—	—	1	$\mu A$
$V_{GS(th)}$	Gate Threshold Voltage	$V_{DS}=V_{GS}, I_D=250\mu A$	0.8	—	1.8	V
$I_{GSS}$	Gate Leakage Current	$V_{GS}=\pm 20V, V_{DS}=0V$	—	—	$\pm 100$	nA
$R_{DS(on)}$	Drain-Source On-Resistance	$V_{GS}=10V, I_D=20A$	—	3.1	4.1	m $\Omega$
		$V_{GS}=4.5V, I_D=20A$	—	4.3	7	
$G_{fs}$	Forward Transconductance	$V_{DS}=5V, I_D=100A$	—	72	—	S
<b>Diode Characteristics</b>						
$V_{SD}$	Diode Forward Voltage	$I_{SD}=25A, V_{GS}=0V$	—	0.8	1.3	V
$I_S$	Diode Continuous Forward Current		—	—	50	A
$t_{rr}$	Reverse Recovery Time	$I_S=20A,$ $di/dt=100A/\mu s$	—	14	—	nS
$Q_{rr}$	Reverse Recovery Charge		—	2.8	—	nC
<b>Dynamic Characteristics</b>						
$R_G$	Gate Resistance	$V_{GS}=0V, V_{DS}=0V,$ Frequency=1MHz	—	1.9	—	$\Omega$
$C_{iss}$	Input Capacitance	$V_{GS}=0V,$ $V_{DS}=15V,$ F=1MHz	—	2999	—	pF
$C_{oss}$	Output Capacitance		—	335	—	
$C_{rss}$	Reverse Transfer Capacitance		—	290	—	
$t_{d(on)}$	Turn-On Delay Time	$V_{DS}=15V,$ $I_D=1A,$ $R_g=3\ \Omega,$ $V_{GS}=4.5V$	—	21	—	nS
$t_r$	Rise Time		—	32	—	
$t_{d(off)}$	Turn-Off Delay Time		—	59	—	
$t_f$	Fall Time		—	34	—	
<b>Gate Charge Characteristics</b>						
$Q_g$	Total Gate Charge	$V_{DS}=25V,$ $V_{GS}=4.5V,$ $I_D=14A$	—	26	—	nC
$Q_{gs}$	Gate-to-Source Charge		—	3.5	—	
$Q_{gd}$	Gate-to-Drain Charge		—	14	—	

## Typical Operating Characteristics

Figure 1. Typ. Output Characteristics

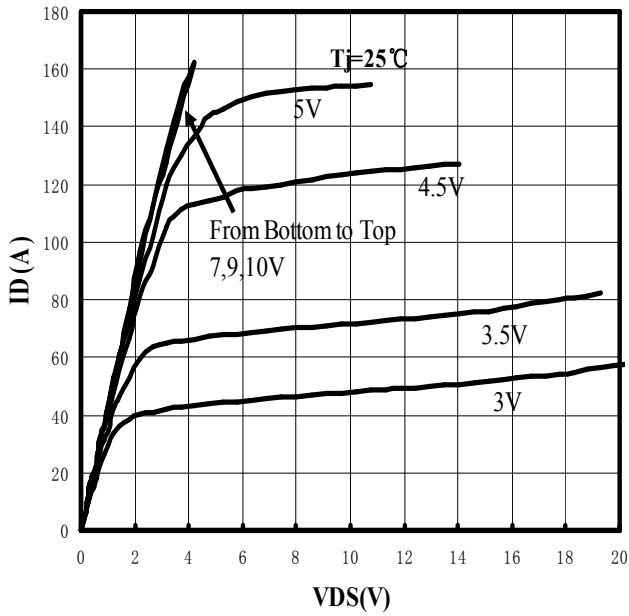


Figure 2. Typ. Output Characteristics

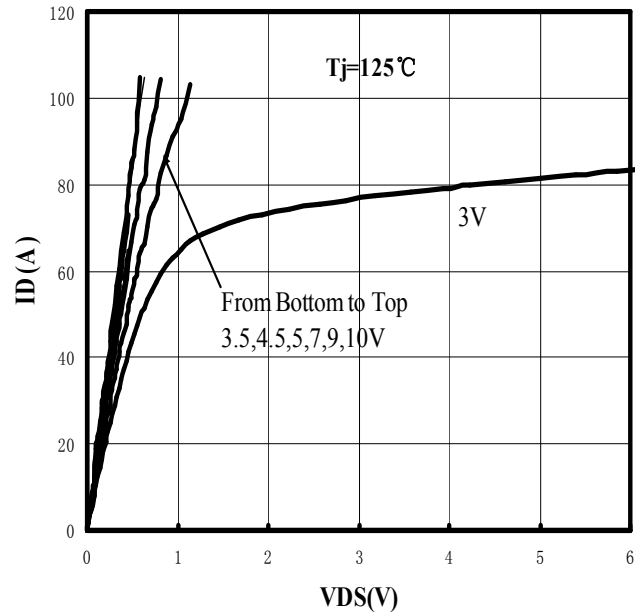


Figure 3. Transfer Characteristics

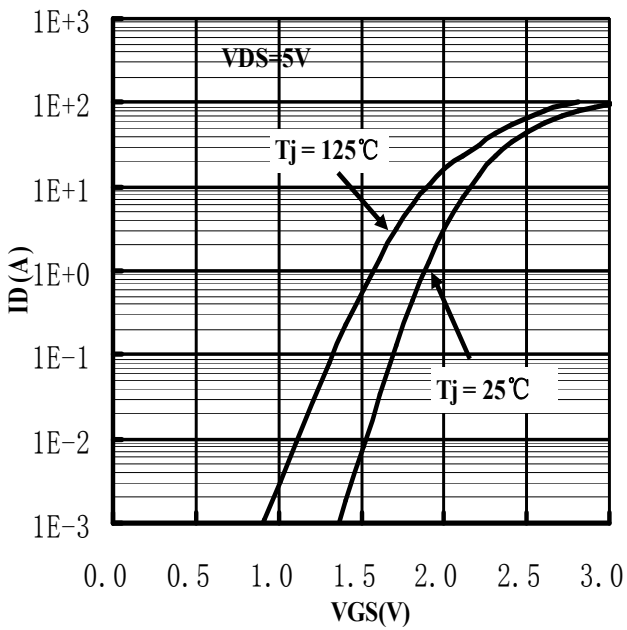
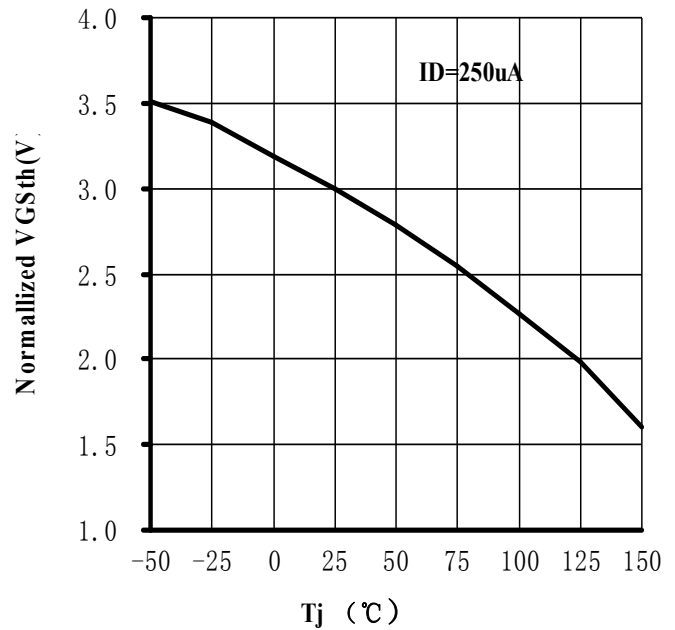
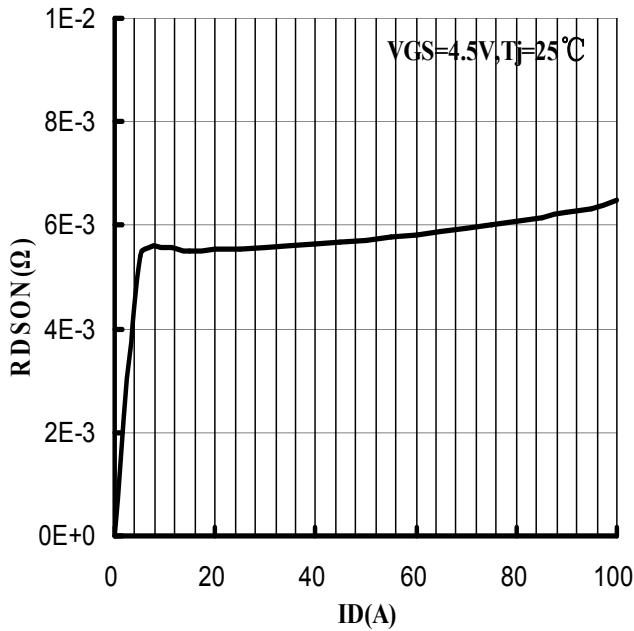


Figure 4. Gate Threshold Voltage Characteristics

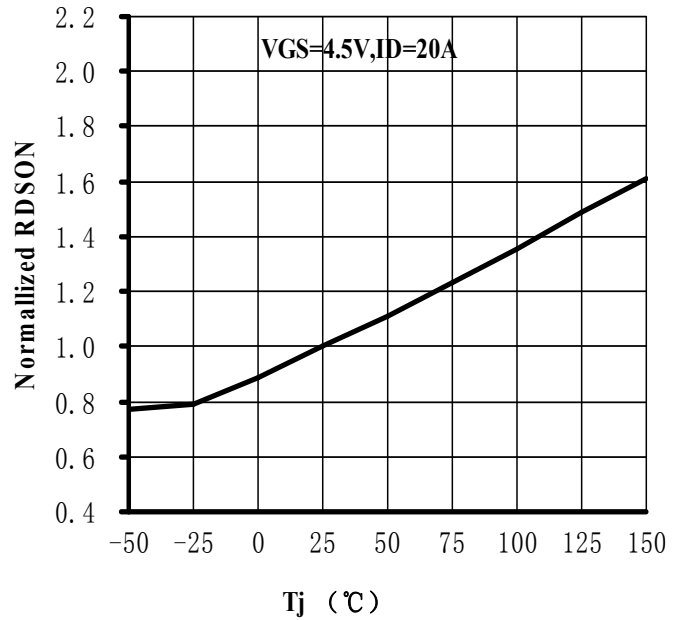


**Typical Operating Characteristics**

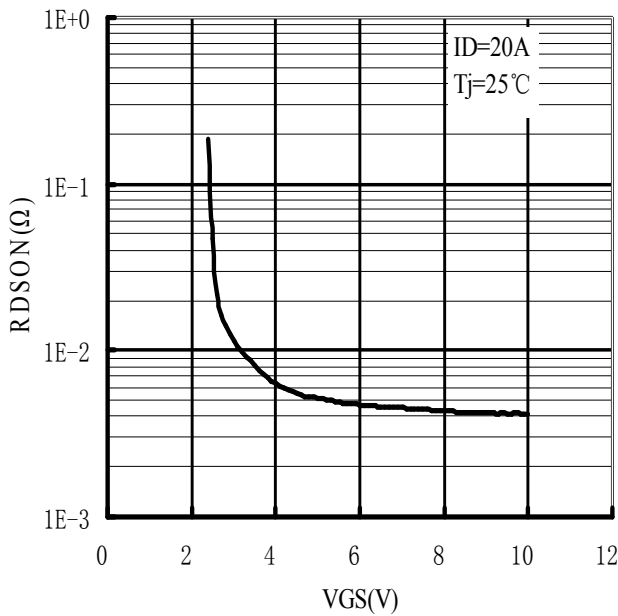
**Figure 5. Rdson vs. Drain Current Characteristics**



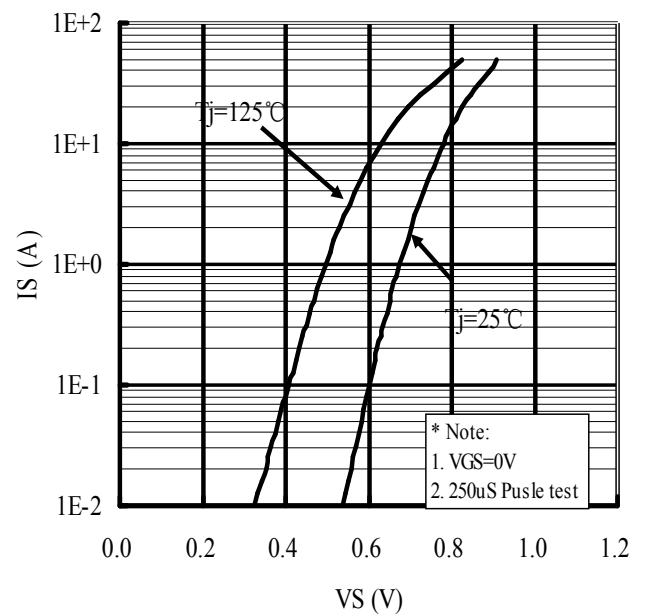
**Figure 6. Rdson vs. Junction Tem Characteristics**



**Figure 7. Rdson vs. VGS Characteristics**

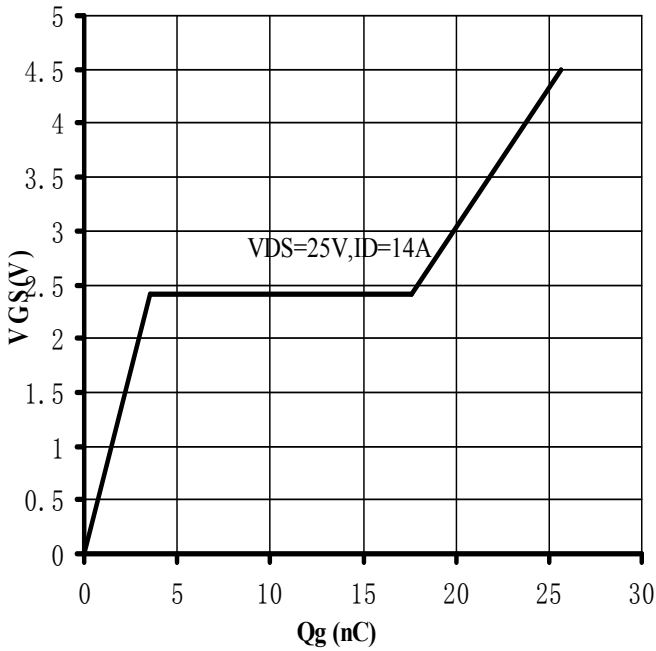


**Figure 8. IS vs. VSD Characteristics**

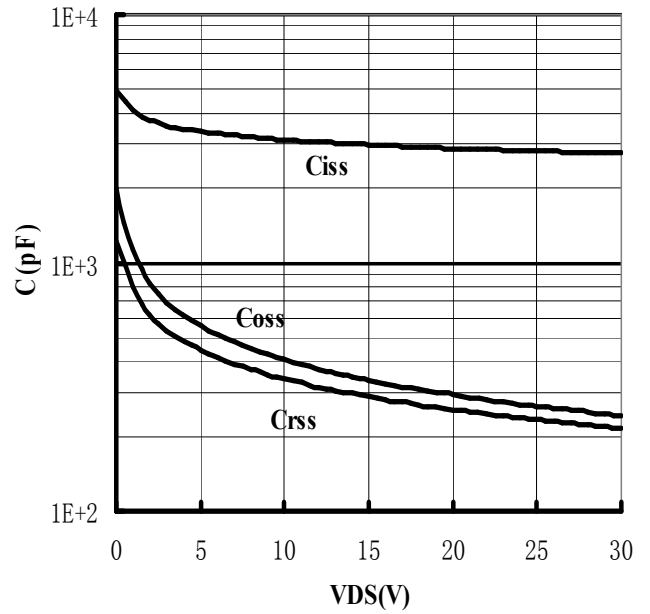


**Typical Operating Characteristics**

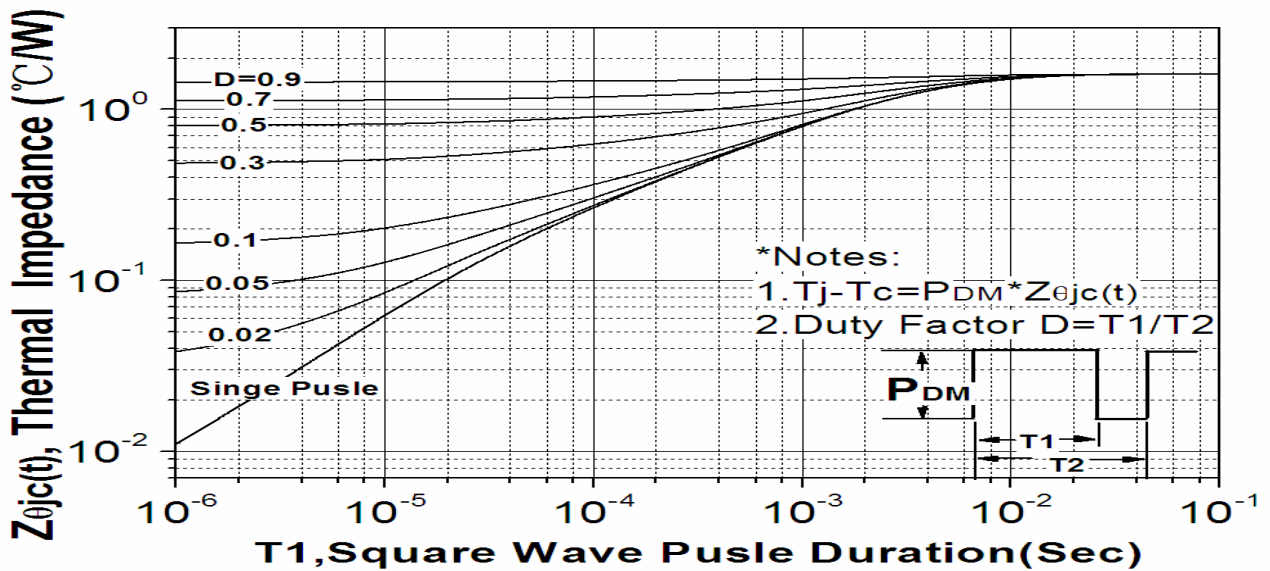
**Figure 9. Gate Charge Characteristics**



**Figure 10. Capacitance Characteristics**

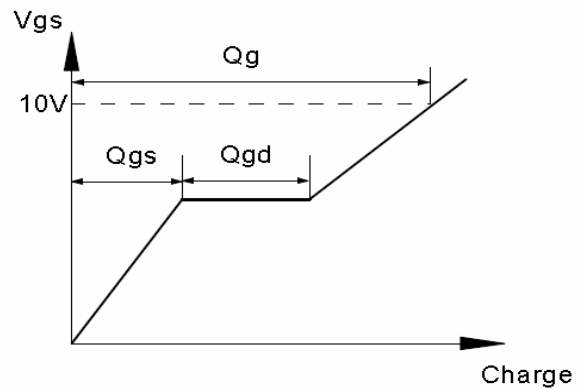
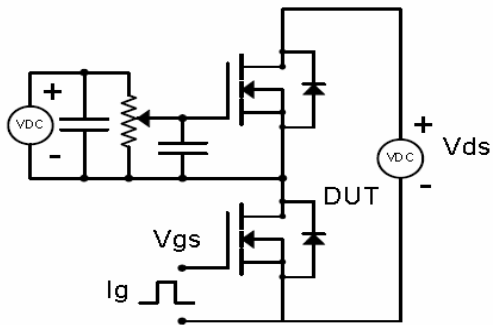


**Figure 11. Thermal Resistance Characteristics**

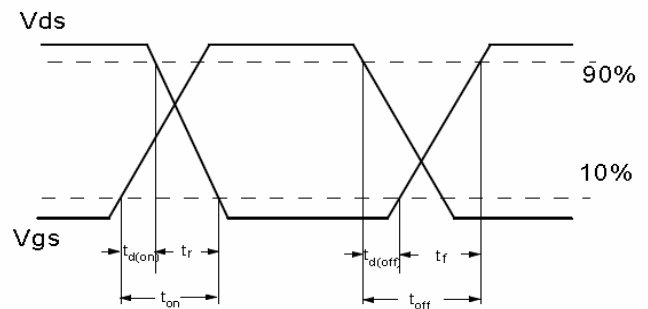
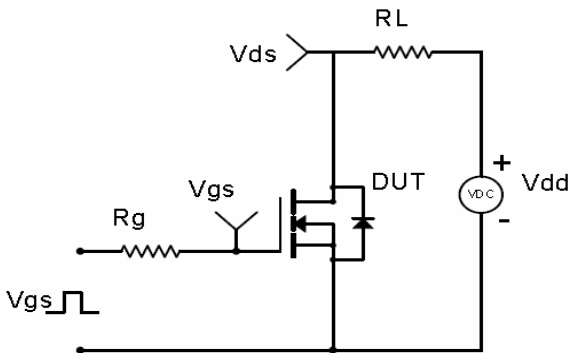


**Test Circuit & Waveform**

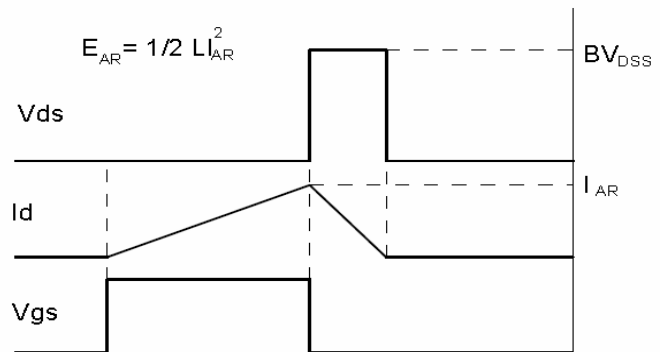
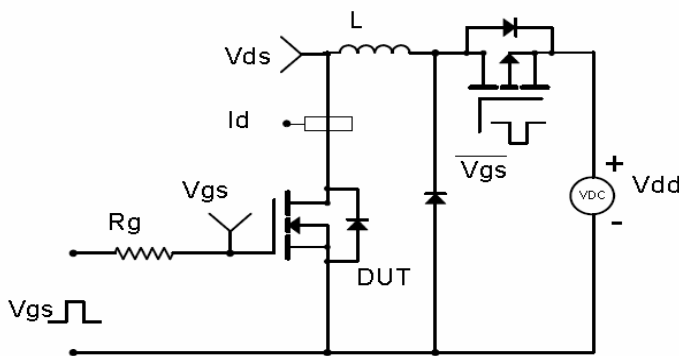
Gate Charge Test Circuit & Waveform



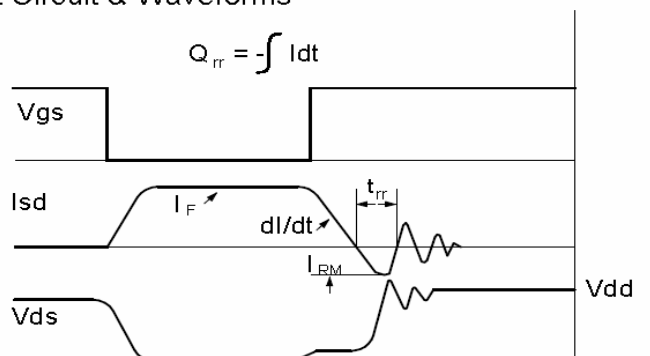
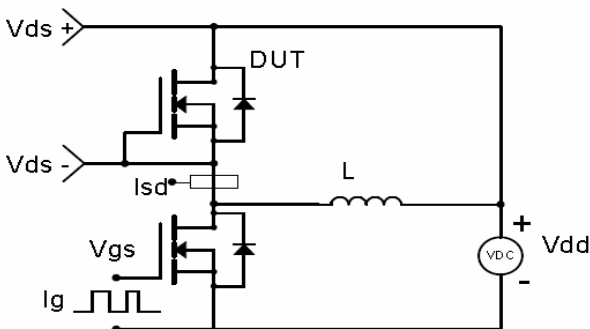
Resistive Switching Test Circuit & Waveforms



Unclamped Inductive Switching (UIS) Test Circuit & Waveforms

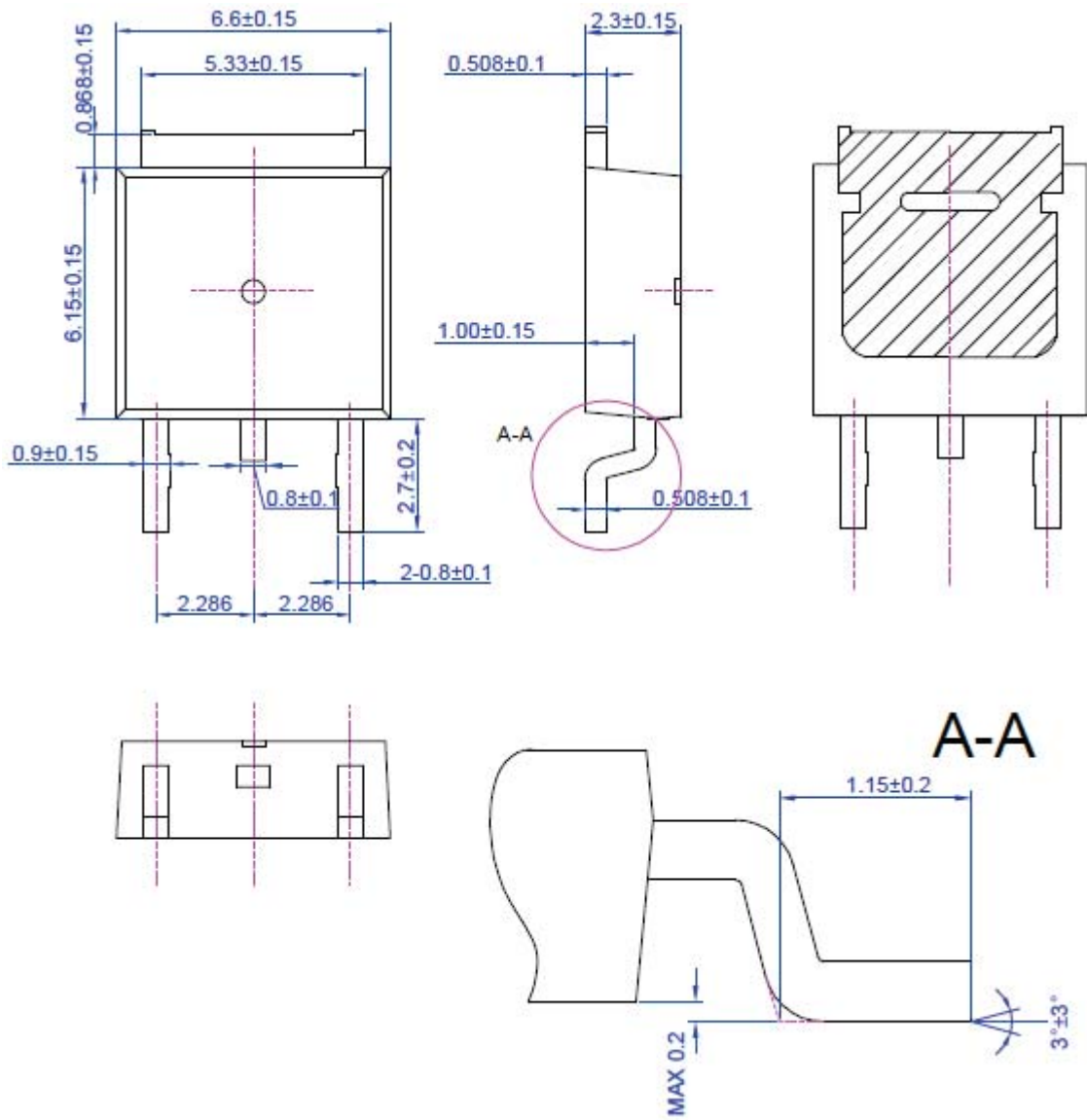


Diode Recovery Test Circuit & Waveforms



**Package Information**

**TO-252**



## Package Information

TO-251

