

RB521G-30HF

RoHS Device
Halogen Free

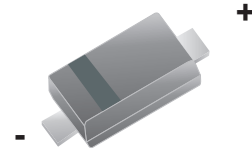

Features

- Ultra small mold type.
- Low VF
- High reliability

Mechanical Data

- Case: SOD-723 Standard package, molded plastic.
- Terminals: Solderable per MIL-STD-750, method 2026.
- Polarity: Indicated by cathode band.
- Mounting position: Any.

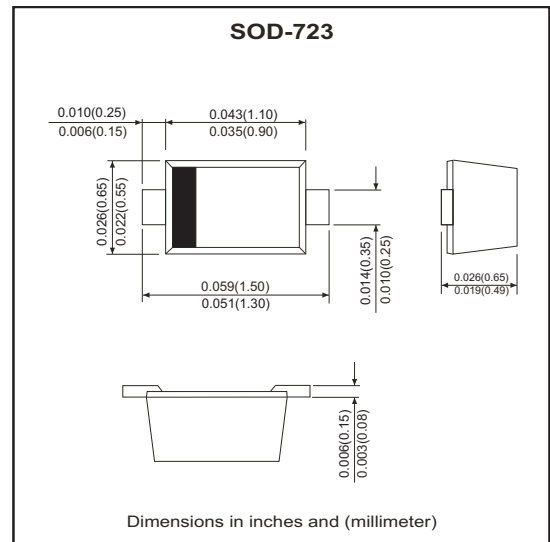

Circuit Diagram

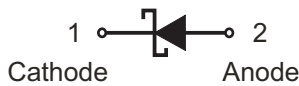

Maximum Rating (at TA=25°C unless otherwise noted)

Parameter	Conditions	Symbol	Limits	Unit
Reverse voltage (DC)		V_R	30	V
Average rectified forward current		I_O	100	mA
Forward current surge peak	60Hz for 1cyc	I_{FSM}	500	mA
Junction temperature		T_j	+125	°C
Storage temperature		T_{STG}	-40 to +125	°C

Electrical Characteristics (at TA=25°C unless otherwise noted)

Parameter	Conditions	Symbol	Min	Typ	Max	Unit
Forward voltage	$I_F = 10 \text{ mA}$	V_F	-	-	0.35	V
Reverse current	$V_R = 10 \text{ V}$	I_R	-	-	10	μA

ELECTRICAL CHARACTERISTIC CURVES (RB521G-30HF)

Fig.1 - Forward Characteristics

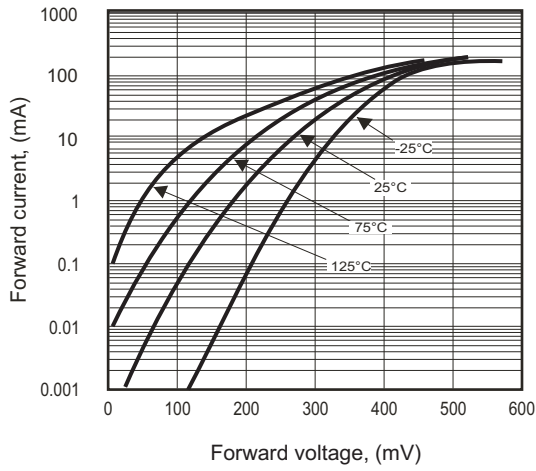

Fig.2 - Reverse Characteristics

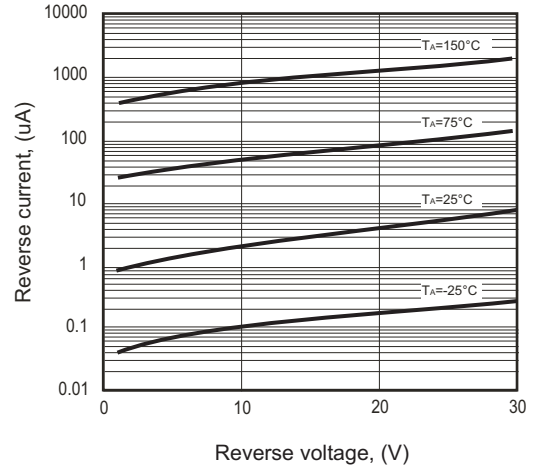

Fig.3 - Capacitance Between Terminals

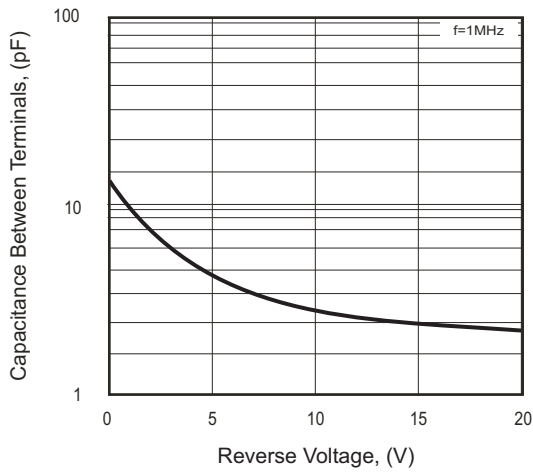

Fig.4 - IFSM-Cycle Characteristics

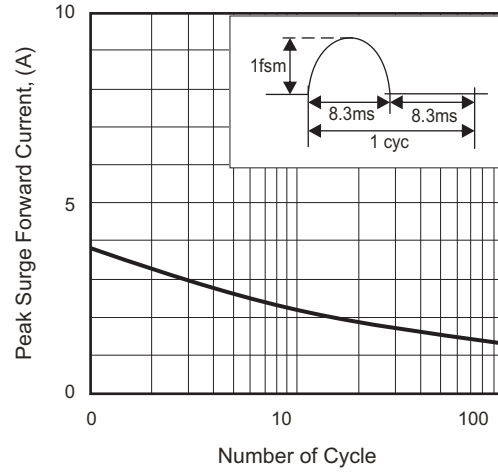
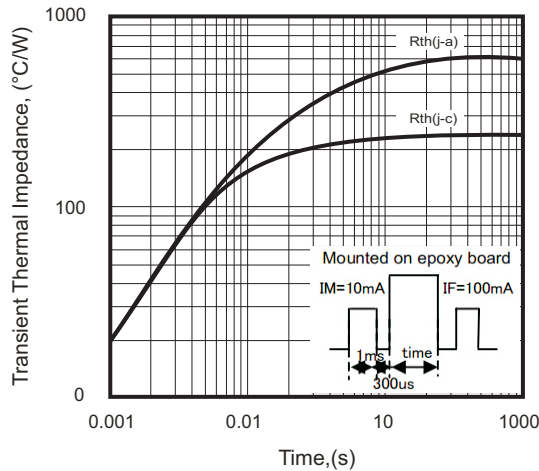
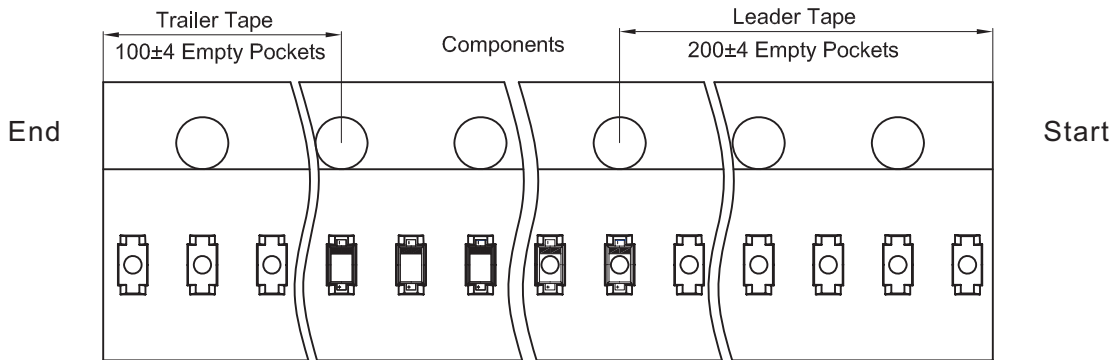
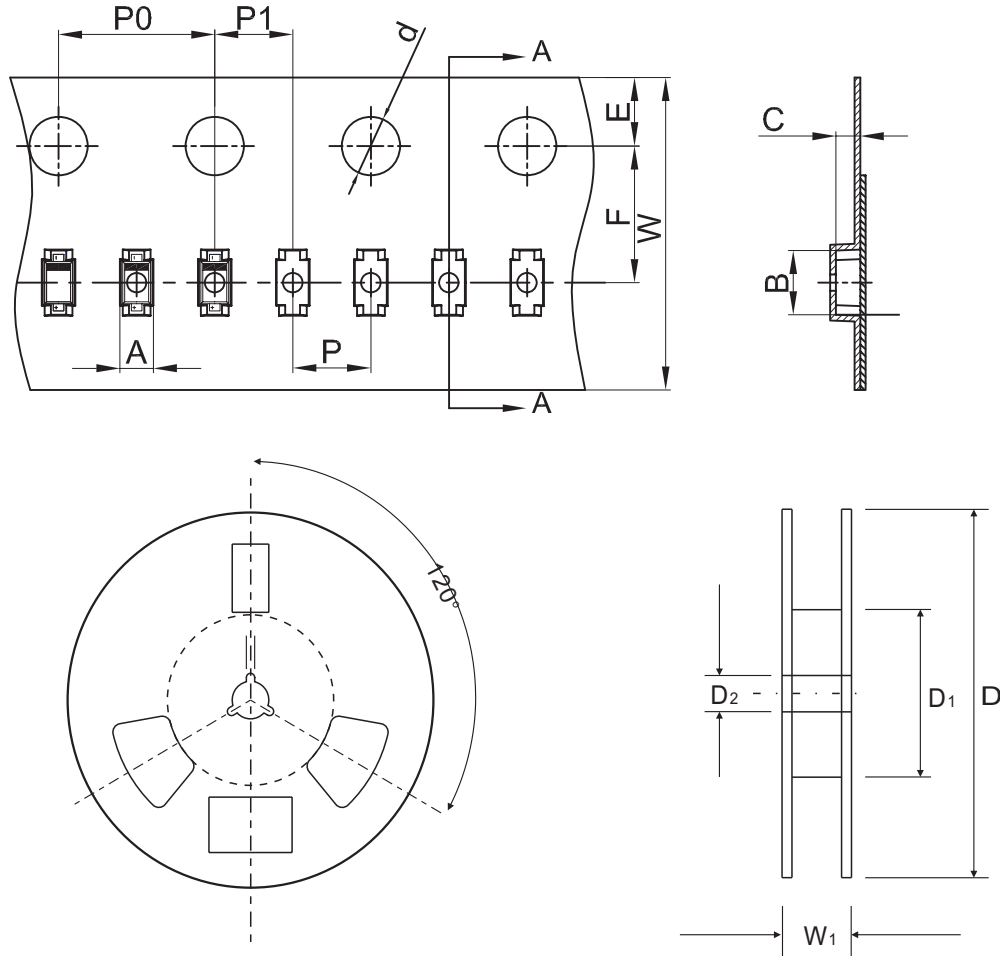

Fig.5 - Rth-t Characteristics



Reel Taping Specification



SOD-723	SYMBOL	A	B	C	d	D	D1	D2
	(mm)	0.70 ± 0.05	1.71 ± 0.05	0.68 ± 0.05	1.50 ± 0.10	178 ± 2.00	54.40 ± 1.00	13.00 ± 1.00
	(inch)	0.028 ± 0.002	0.067 ± 0.002	0.027 ± 0.002	0.059 ± 0.004	7.008 ± 0.039	2.142 ± 0.039	0.512 ± 0.039

SOD-723	SYMBOL	E	F	P	P0	P1	W	W1
	(mm)	1.75 ± 0.10	3.50 ± 0.10	2.00 ± 0.10	4.00 ± 0.10	2.00 ± 0.10	8.00 ± 0.30 / - 0.10	12.30 ± 1.00
	(inch)	0.069 ± 0.004	0.138 ± 0.004	0.079 ± 0.004	0.158 ± 0.004	0.079 ± 0.004	0.315 ± 0.012 / - 0.004	0.484 ± 0.039

Marking Code

Part Number	Marking Code	
RB521G-30HF	F	F Σ

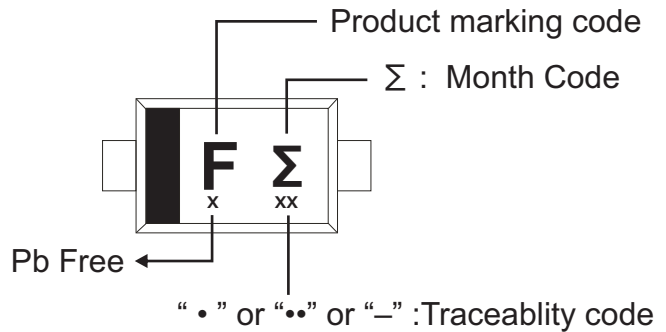

Month Code:

Month	Odd Year (per A.D.)	Even Year (per A.D.)
Jan	1	E
Feb	2	F
Wer	3	H
Apr	4	J
May	5	K
Jun	6	L

Month	Odd Year (per A.D.)	Even Year (per A.D.)
Jul	7	N
Aug	8	P
Sep	9	U
Oct	T	X
Nov	V	Y
Dec	C	Z

Suggested PAD Layout

SIZE	SOD-723	
	(mm)	(inch)
A	1.260	0.050
B	0.600	0.024
C	0.700	0.028

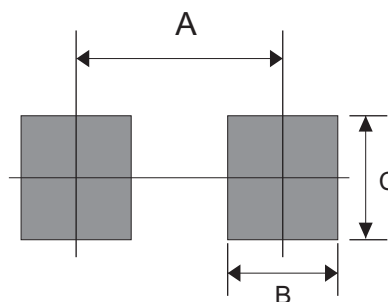

Standard Packaging

Case Type	REEL PACK	
	REEL (pcs)	Reel Size (inch)
SOD-723	4,000	7
	8,000	7