

1MHz 18V 2A Synchronous COT Step-Down Converter with Force PWM Operation

Features

- 140mΩ/70mΩ Low $R_{DS(ON)}$ internal FETs
- High Efficiency Synchronous-Mode Operation
- Wide Input Range:4.5V to 18V
- Feedback Voltage 0.6V
- 1MHz Switch Frequency
- Up to 2A Output Current
- COT control to achieve fast transient responses
- Force PWM Operation
- Integrated internal compensation
- Stable with Low ESR Ceramic Output Capacitors
- Over Current Protection with Hiccup Mode
- Thermal Shutdown
- Inrush Current Limit and Soft Start
- Build in Input Over Voltage Protection
- Available in SOT23-6 Package

Description

The TMI32520 is high efficiency 1MHz, Constant on-Time (COT) control mode synchronous step-down DC-DC converter capable of delivering up to 2A current with force PWM operation. TMI32520 integrates main switch and synchronous switch with very low $R_{DS(ON)}$ to minimize the conduction loss. Low output voltage ripple and small external inductor and capacitor size are achieved with 1MHz switching frequency. It adopts the COT architecture to achieve fast transient responses for high voltage step down applications.

The TMI32520 requires a minimum number of readily available standard external components and is available in a 6-pin SOT23-6 ROHS compliant package.

Application

- Digital Set Top Boxes
- Flat Panel Television and Monitors
- Notebook computer
- Wireless and DSL Modems

Typical Application

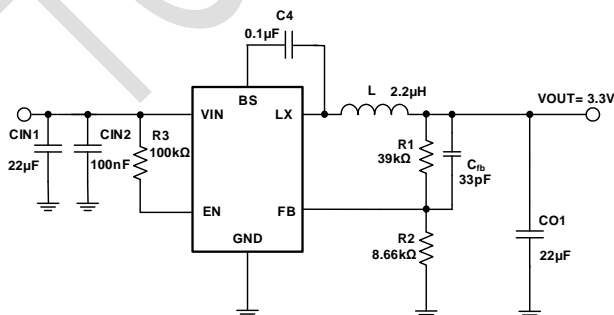

TMI32520 Typical Application Circuits

Efficiency

$V_{OUT}=3.3V$, $I_{OUT}=0.01A$ to 2A, $T_A=25^{\circ}C$

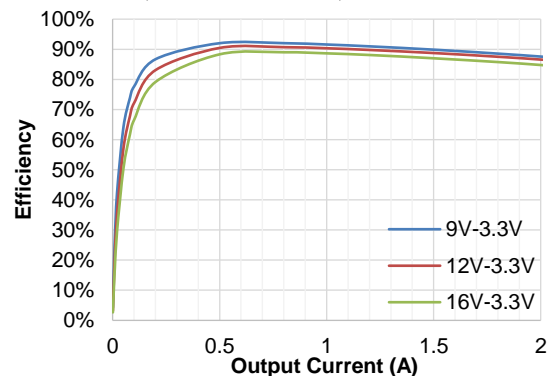

Absolute Maximum Ratings^(Note 1)

Parameter	Min	Max	Unit
Input Supply Voltage, EN	-0.3	20	V
LX Voltages	-0.3	20	V
LX Voltage (<10ns transient)	-5	22	V
FB Voltage	-0.3	6	V
BS Voltage	-0.3	23	V
Storage Temperature Range	-65	150	°C
Junction Temperature ^(Note2)	150		°C
Power Dissipation	1000		mW
Lead Temperature (Soldering, 10s)	260		°C

Package

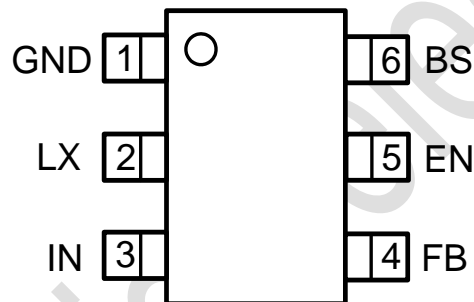

SOT23-6

Top Marking: TT28xxx

TT28: Device Code

xxx: Inside Code

Order Information

Part Number	Package	Top Marking	Quantity/Reel
TMI32520	SOT23-6	TT28xxx	3000

TMI32520 devices are Pb-free and RoHS compliant.

Pin Functions

Pin	Name	Function
1	GND	Ground Pin
2	LX	Switching Pin
3	IN	Power supply Pin
4	FB	Output Voltage feedback input. Connect FB to the center point of the external resistor divider.
5	EN	Drive this pin to a logic-high to enable the IC. Drive to a logic-low to disable the IC and enter micro-power shutdown mode. Don't floating.
6	BS	Bootstrap. A capacitor connected between LX and BS pins is required to form a floating supply across the high-side switch driver.

ESD Rating

Items	Description	Value	Unit
V_{ESD_HBM}	Human Body Model for all pins	±2000	V
V_{ESD_CDM}	Charged Device Model for all pins	±2000	V

JEDEC specification JS-001

Recommended Operating Conditions

Items	Description	Min	Max	Unit
Voltage Range	IN	4.5	18	V
T_J	Operating Junction Temperature	-40	125	°C

Thermal Resistance (Note3)

Items	Description	Value	Unit
θ_{JA}	Junction-to-ambient thermal resistance	120	°C/W
θ_{JC}	Junction-to-case(top) thermal resistance	65	°C/W
ψ_{JC}	Junction-to-case(top) characterization parameter	8.0	°C/W

Electrical Characteristics (Note 4)

$V_{IN}=12V$, $V_{OUT}=3.3V$, $T_A = 25^{\circ}C$, unless otherwise noted.

Parameter	Conditions	Min	Typ	Max	Unit
Input Voltage Range		4.5		18	V
OVP Threshold			19.3		V
UVLO Rising Threshold			4.3	4.5	V
UVLO Hysteresis			0.45		V
Quiescent Current	$V_{EN}=2V$, $V_{FB}=V_{REF} \times 105\%$		350		μA
Standby Current	$V_{IN}=12V$, $V_{EN}=2V$, $I_{OUT}=0A$		9	12	mA
Shutdown Current	$V_{IN}=12V$, $V_{EN}=0V$		5	10	μA
Regulated Feedback Voltage	$T_A=25^{\circ}C$	0.591	0.6	0.609	V
High-Side Switch On-Resistance			140		m Ω
Low-Side Switch On-Resistance			70		m Ω
High-Side Switch Leakage Current	$V_{EN}=0V$, $V_{LX}=0V$	1		10	μA
Switch Valley Current Limit	Minimum Duty Cycle		3		A
On Time	$V_{IN}=12V$, $V_{OUT}=1.2V$, $I_{OUT}=1A$	70	100	130	ns
Oscillation Frequency			1		MHz
Maximum Duty Cycle			85		%
Minimum On-Time			130		ns
Soft Start Time		0.4	0.6	1.0	ms
Hiccup on Time			1		ms
Hiccup Time Before Restart			4		ms
EN Rising Threshold		1.0	1.1	1.2	V
EN Hysteresis			140		mV
Thermal Shutdown Hysteresis (Note 4)			155		$^{\circ}C$
Thermal Shutdown Hysteresis (Note 4)			25		$^{\circ}C$

Note 1: Absolute Maximum Ratings are those values beyond which the life of a device may be impaired.

Note 2: T_J is calculated from the ambient temperature T_A and power dissipation P_D according to the following formula: $T_J = T_A + P_D \times \theta_{JA}$. The maximum allowable continuous power dissipation at any ambient temperature is calculated by $P_{D(MAX)} = (T_{J(MAX)} - T_A) / \theta_{JA}$.

Note 3: Measured on JESD51-7, 4-layer PCB.

Note 4: Thermal shutdown threshold and hysteresis are guaranteed by design.

Block Diagram

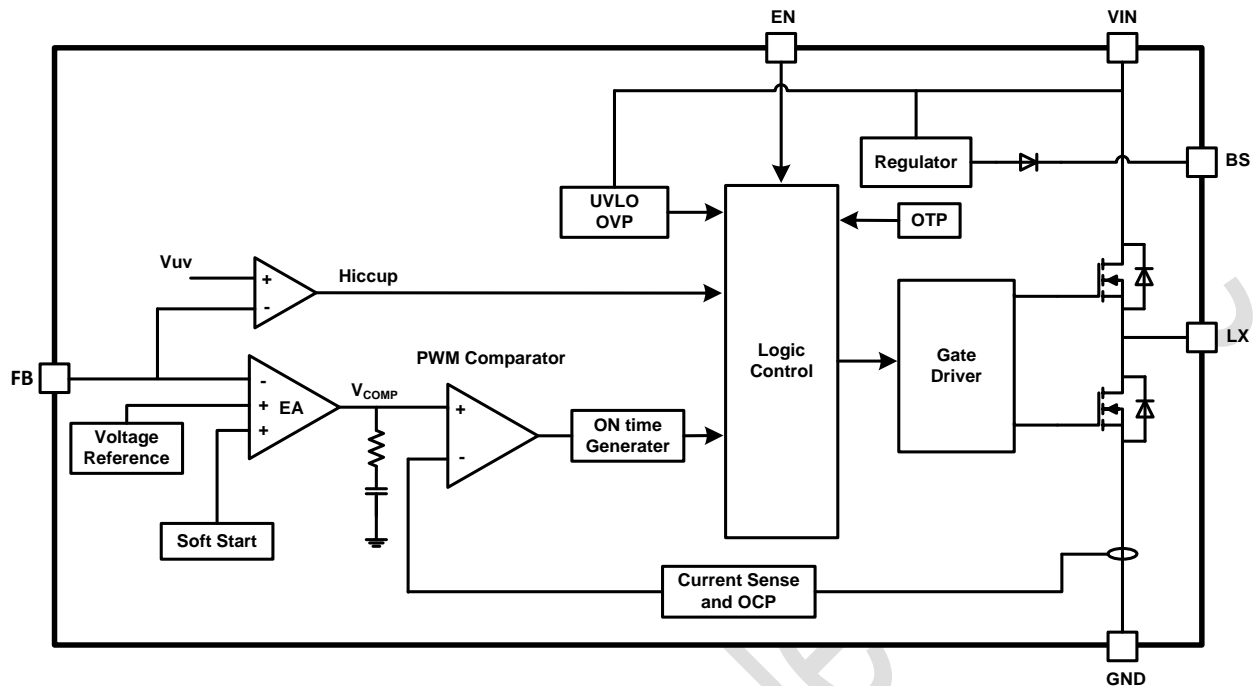

Figure 1. TMI32520 Block Diagram

Operation Description

Internal Regulator

The TMI32520 is a constant on-time (COT) step down DC/DC converter that provides excellent transient response with no extra external compensation components. This device contains low resistance, high voltage high side and low side power MOSFETs, and operates at 1MHz force PWM operating frequency to ensure a compact, high efficiency design with excellent AC and DC performance.

Error Amplifier

TMI32520 adopts operational transconductance amplifier (OTA) as error amplifier. The error amplifier compares the FB pin voltage with the internal FB reference (V_{REF}) and outputs a current proportional to the difference between the two. This output current is then used to charge or discharge the internal compensation network to form the V_{COMP} voltage, which is used to compare with the low side power MOSFET current sensing signal and trigger on time pulse. The optimized internal compensation network minimizes the external component counts and simplifies the control loop design.

Internal Soft-Start

The soft-start is implemented to prevent the converter output voltage from overshooting during startup. When the chip starts, the internal circuitry generates a soft-start voltage (SS) ramping up from 0V to V_{REF} . When it is lower than the internal FB reference (V_{REF}), SS overrides REF so the error amplifier uses SS as the reference. When SS is higher than V_{REF} , V_{REF} regains control. The SS time is internally fixed to 0.6ms typically.

Over-Current-Protection and Short Circuits Protection

The TMI32520 has cycle-by-cycle valley current limit function. When the inductor current valley value is larger than the valley current limit during low side MOSFET on state, the device enters into valley over current protection mode and low side MOSFET keeps on state until inductor current drops down to the value equal or lower than the valley current limit, and then on time pulse could be generated and high side MOSFET could turn on again.

If the output is short to GND and the output voltage drop until feedback voltage V_{FB} is below the output under-voltage V_{UV} threshold which is typically 55% of V_{REF} , TMI32520 enters into hiccup mode to periodically disable and restart switching operation. The hiccup mode helps to reduce power dissipation and thermal rise during output short condition. The period of TMI32520 hiccup mode is typically 5ms.

Startup and Shutdown

If both VIN and EN are higher than their appropriate thresholds, the chip starts switching operation. The reference block starts first, generating stable reference voltage and currents, and then the internal regulator is enabled. The regulator provides stable supply for the remaining circuitries. Three events can shut down the chip: EN low, VIN low and thermal shutdown. In the shutdown procedure, the signaling path is first blocked to avoid any fault triggering. The V_{COMP} voltage and the internal supply rail are then pulled down. The floating driver is not subject to this shutdown command.

Application Information

Setting the Output Voltage

The external resistor divider is used to set the output voltage (see Typical Application on page 1).

Table 1: Selection for Common Output Voltages

V_{OUT} (V)	R1 (k Ω)	R2 (k Ω)	C_{FB} (pF)	L (μ H)
5	39	5.36	33	2.2
3.3	39	8.66	33	2.2
2.5	39	12.4	33	2.2
1.8	39	19.6	33	2.2
1.5	39	26.1	33	2.2
1.2	39	39	33	1.5
1	39	59	33	1.0

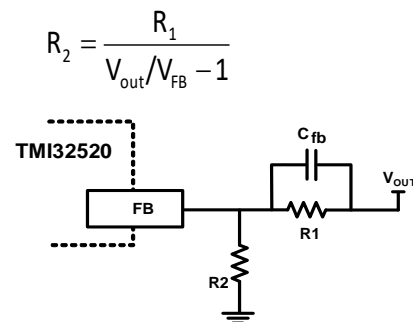

Figure 2. Feedback Network

Selecting the Inductor

A DC current rating of at least 25% percent higher than the maximum load current is recommended for most applications. Inductance value is related to inductor ripple current value, input voltage, output voltage setting and switching frequency. The inductor value can be derived from the following equation:

$$L = \frac{V_{OUT} \times (V_{IN} - V_{OUT})}{V_{IN} \times \Delta I_L \times f_{OSC}}$$

Where ΔI_L is the inductor ripple current. TMI32520 is force PWM operation mode. In null load condition, the average inductor current is zero and valley inductor current is $-\Delta I_L/2$. the minus current valley is limited to around -1.4A, so the inductor ripple current ΔI_L should be smaller than 2.8A, and the minimum inductance value is limited. The maximum inductor peak current is:

$$I_{L(MAX)} = I_{LOAD} + \frac{\Delta I_L}{2}$$

For 5V and 3.3V output voltage, the recommended inductance should not be smaller than 1.0 μ H.

Selecting the Output Capacitor

The output capacitor (Co1) is required to maintain the DC output voltage. Ceramic, tantalum, or low ESR electrolytic capacitors are recommended. Low ESR capacitors are preferred to keep the output voltage ripple low. The output voltage ripple can be estimated by:

$$\Delta V_{OUT} = \frac{V_{OUT}}{f_s \times L} \times \left[1 - \frac{V_{OUT}}{V_{IN}} \right] \times \left[R_{ESR} + \frac{1}{8 \times f_s \times C_2} \right]$$

Where L is the inductor value and R_{ESR} is the equivalent series resistance (ESR) value of the output capacitor. In the case of ceramic capacitors, the impedance at the switching frequency is dominated by the capacitance. The output voltage ripple is mainly caused by the capacitance. For simplification, the output voltage ripple can be estimated by:

$$\Delta V_{OUT} = \frac{V_{OUT}}{8 \times f_s^2 \times L \times C_2} \times \left[1 - \frac{V_{OUT}}{V_{IN}} \right]$$

In the case of tantalum or electrolytic capacitors, the ESR dominates the impedance at the switching frequency. For simplification, the output ripple can be approximated to:

$$\Delta V_{OUT} = \frac{V_{OUT}}{f_s \times L} \times \left[1 - \frac{V_{OUT}}{V_{IN}} \right] \times R_{ESR}$$

The characteristics of the output capacitor also affect the stability of the regulation system. The TMI32520 can be optimized for a wide range of capacitance and ESR values.

Typical Performance Characteristics

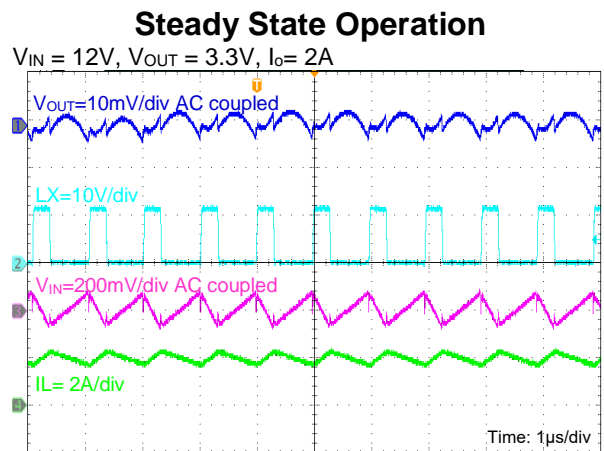
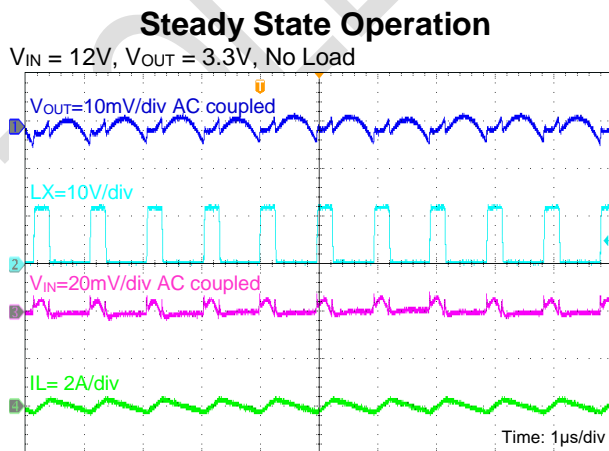
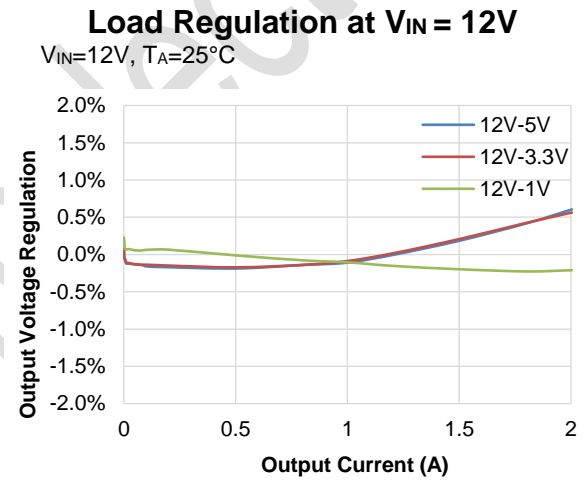
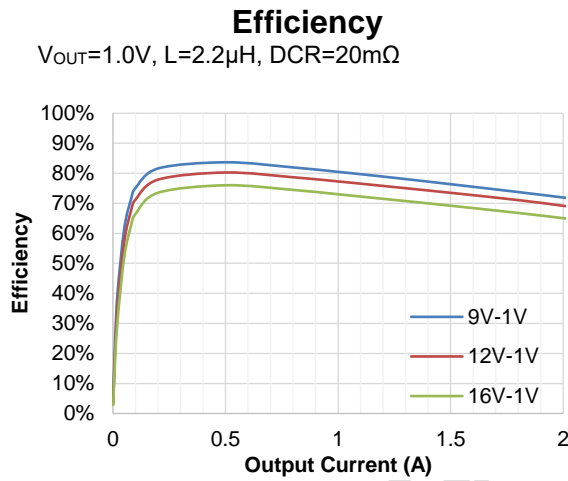
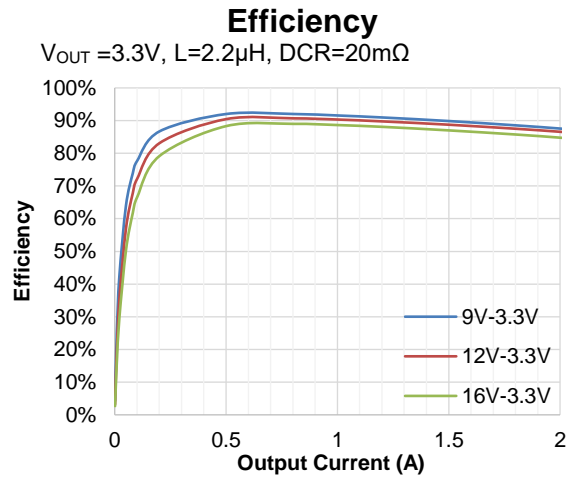
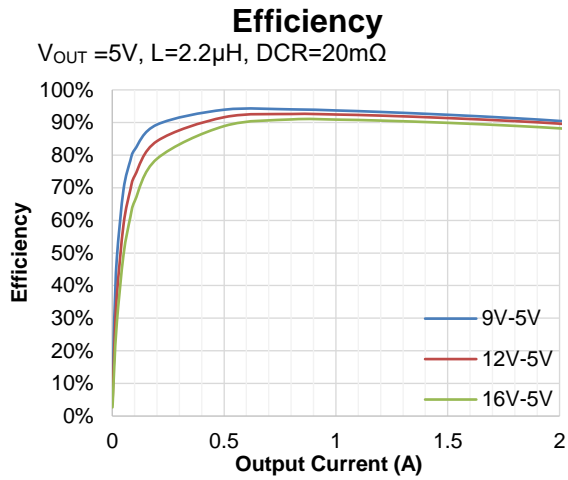

Typical Performance Characteristics(continued)

Load Transient

$V_{IN} = 12V, V_{OUT} = 3.3V, I_o = 0A \text{ to } 1A$

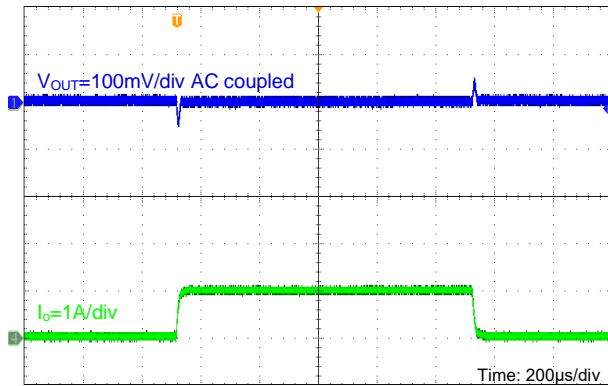

Load Transient

$V_{IN} = 12V, V_{OUT} = 3.3V, I_o = 1A \text{ to } 2A$

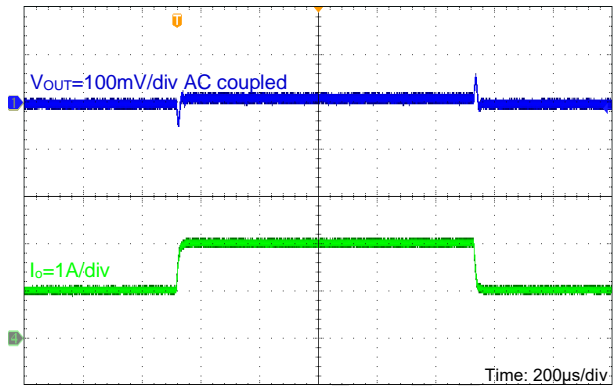

Output Short Entry

$V_{IN} = 12V, V_{OUT} = 3.3V, \text{No Load}$

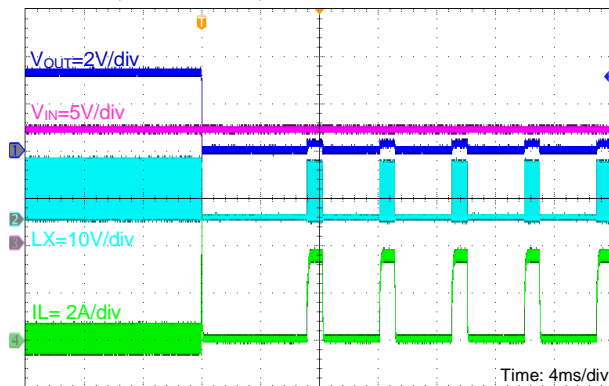

Output Short Recovery

$V_{IN} = 12V, V_{OUT} = 3.3V, \text{No Load}$

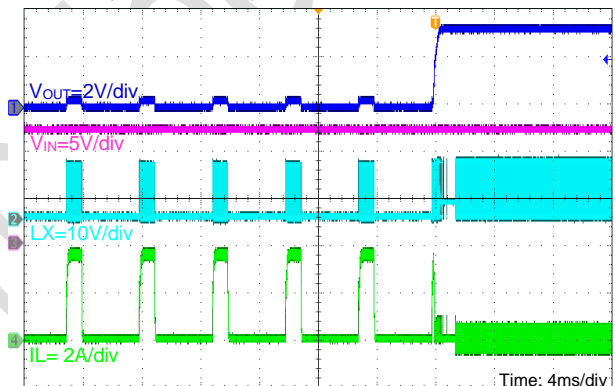

Output Short Entry

$V_{IN} = 12V, V_{OUT} = 3.3V, I_o = 2A$

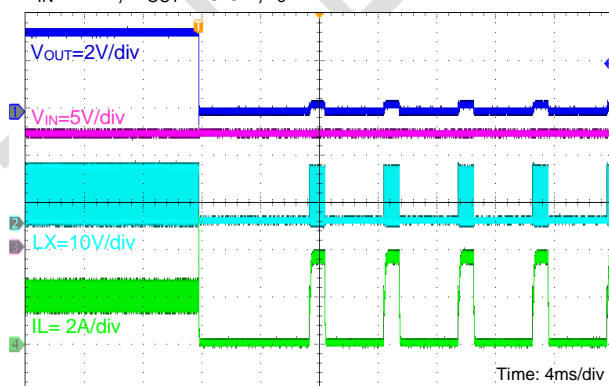

Output Short Recovery

$V_{IN} = 12V, V_{OUT} = 3.3V, I_o = 2A$

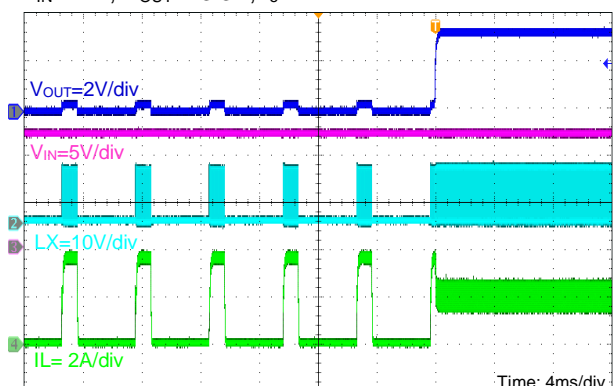

Typical Performance Characteristics (continued)

Input Power On

$V_{IN} = 12V, V_{OUT} = 3.3V, I_o = 2A$

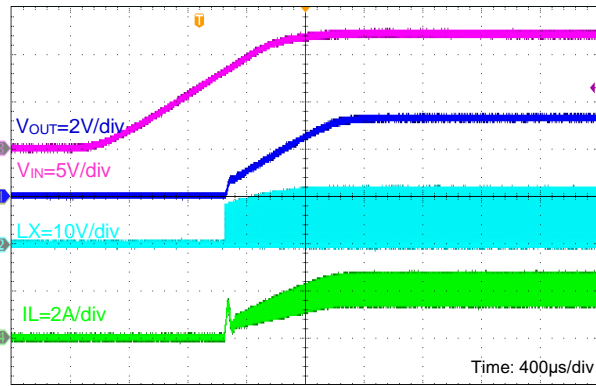

Input Power Down

$V_{IN} = 12V, V_{OUT} = 3.3V, I_o = 2A$

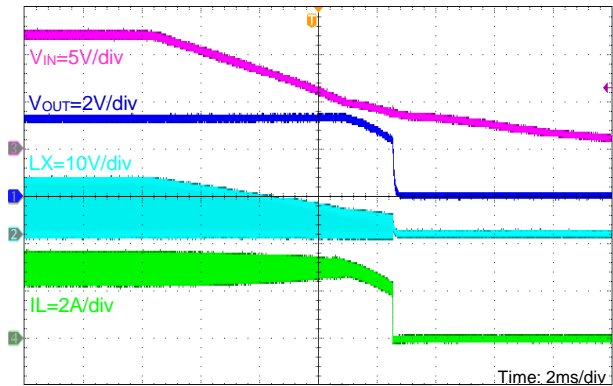

EN Enable

$V_{IN} = 12V, V_{OUT} = 3.3V, I_o = \text{No Load}$

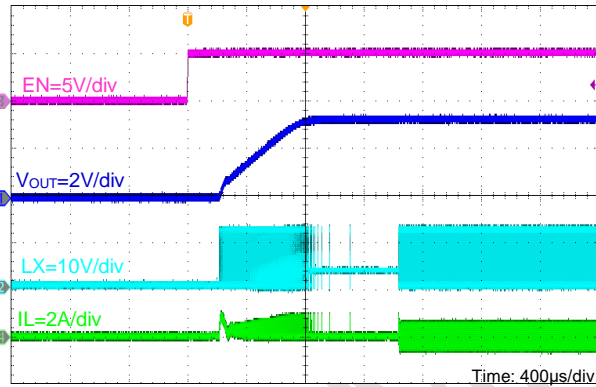

EN Disable

$V_{IN} = 12V, V_{OUT} = 3.3V, I_o = \text{No Load}$

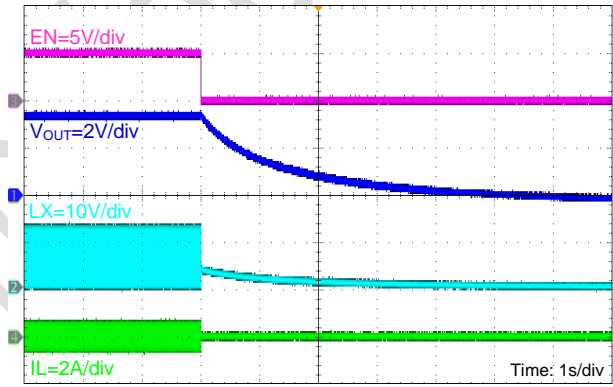

EN Enable

$V_{IN} = 12V, V_{OUT} = 3.3V, I_o = 2A$

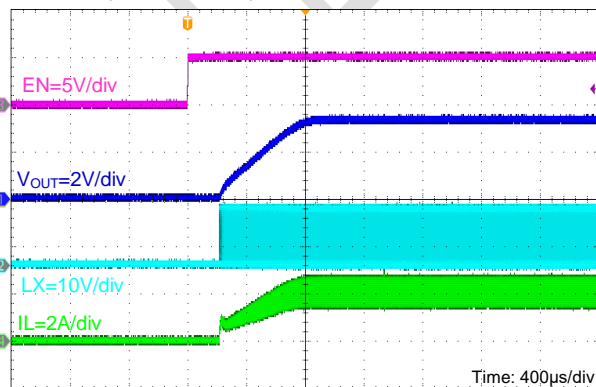

EN Disable

$V_{IN} = 12V, V_{OUT} = 3.3V, I_o = 2A$

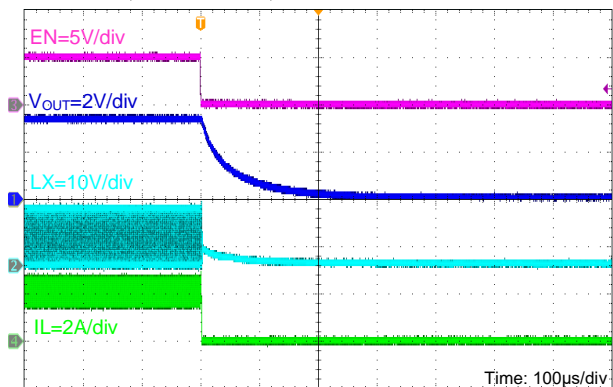

Typical Application Circuits

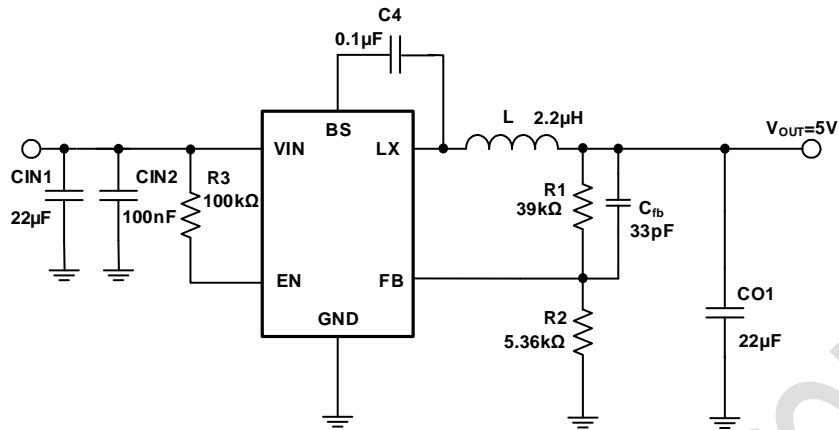

Figure 4. 12V_{IN}, 5V Output

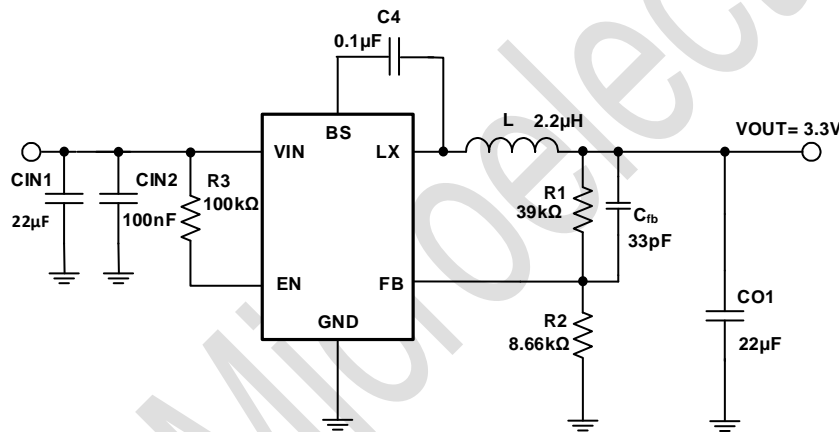

Figure 5. 12V_{IN}, 3.3V Output

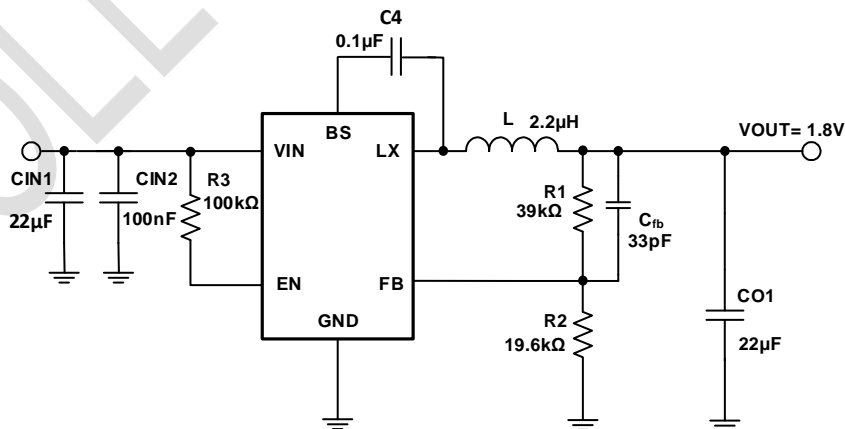

Figure 6. 12V_{IN}, 1.8V Output

Typical Application Circuits(continued)

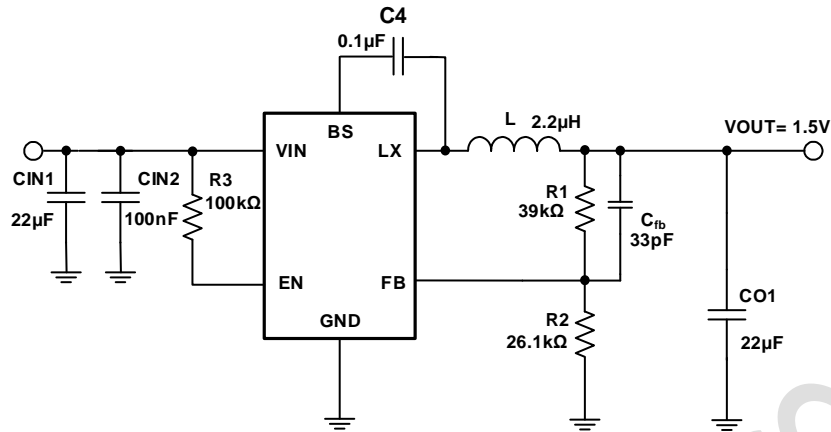

Figure 7. 12V_{IN}, 1.5V Output

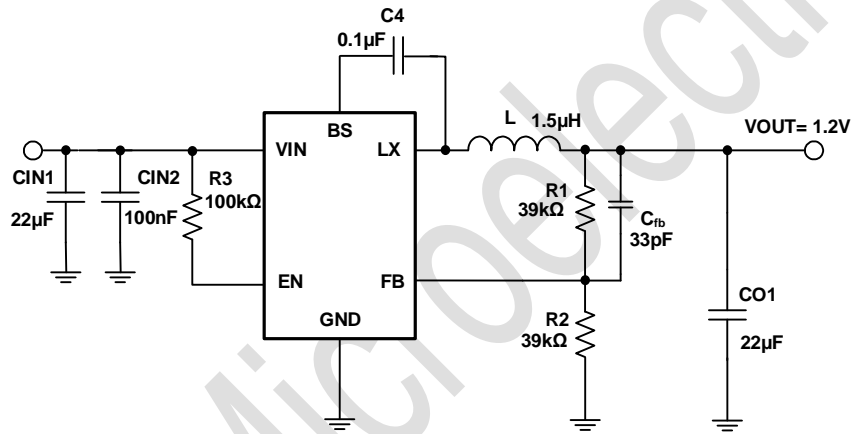

Figure 8. 12V_{IN}, 1.2V Output

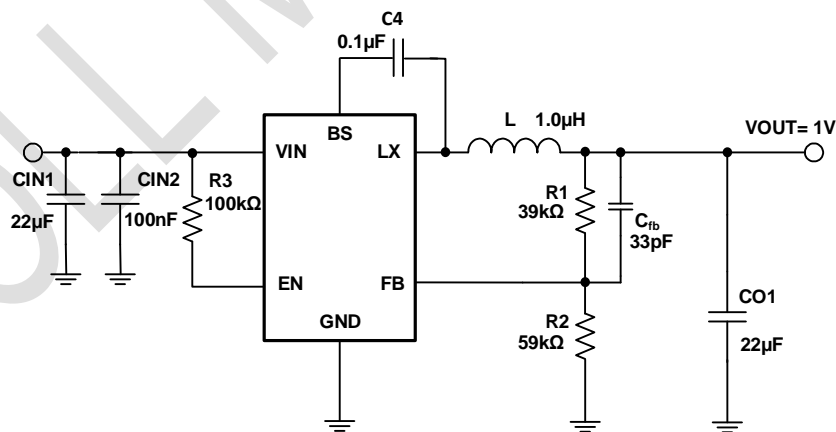

Figure 9. 12V_{IN}, 1V Output

PCB Layout Guide

PCB layout is very important to achieve stable operation. It is highly recommended to duplicate EVB layout for optimum performance. If change is necessary, please follow these guidelines and take Figure 3 for reference.

- 1) Keep the path of switching current short and minimize the loop area formed by Input capacitor, IN pin and GND.
- 2) Bypass ceramic capacitors are suggested to be put close to the IN Pin.
- 3) Ensure all feedback connections are short and direct. Place the feedback resistors as close to the chip as possible.
- 4) VOUT, LX away from sensitive analog areas such as FB.
- 5) Connect IN, LX, and especially GND respectively to a large copper area to cool the chip to improve thermal performance and long-term reliability.

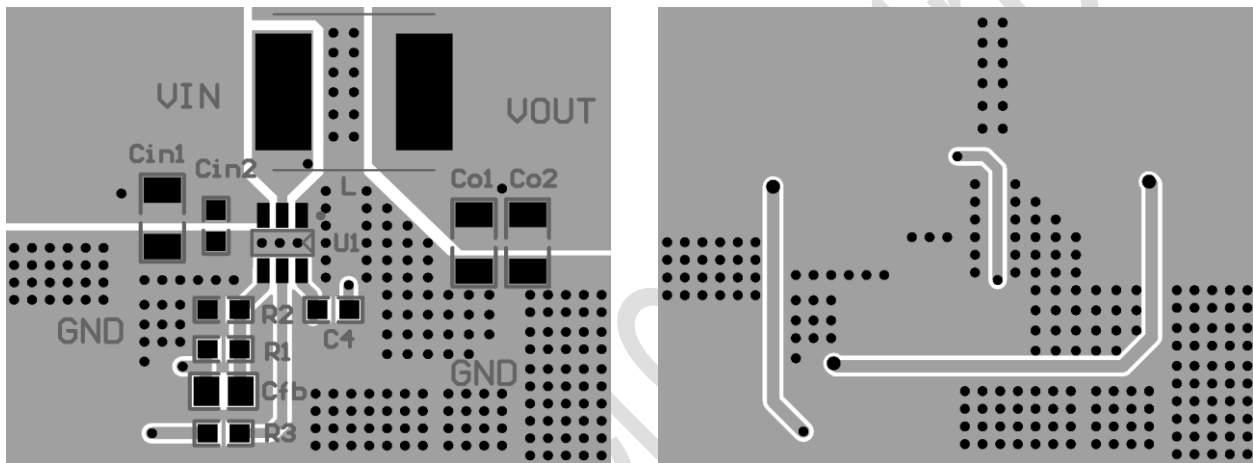
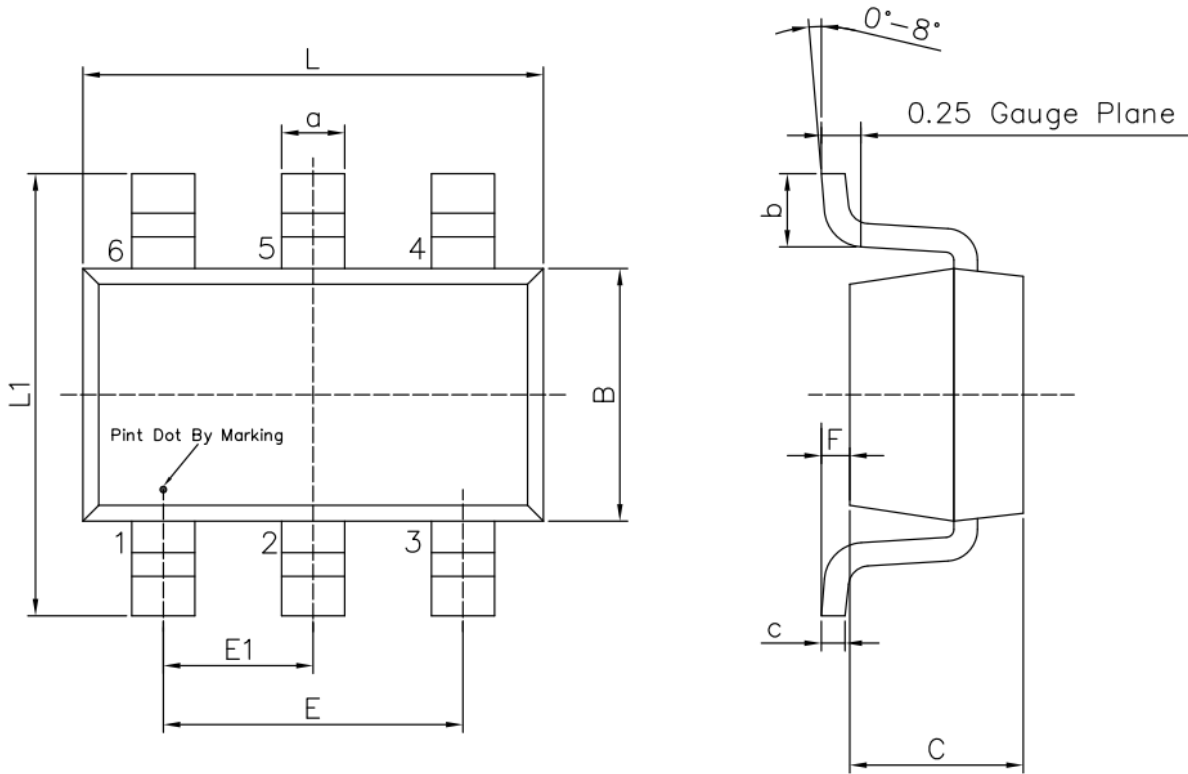

Figure 3. Sample of PCB Layout

Package Information

SOT23-6



Unit: mm

Symbol	Dimensions In Millimeters		Symbol	Dimensions In Millimeters	
	Min	Max		Min	Max
L	2.82	3.02	E1	0.85	1.05
B	1.50	1.70	a	0.35	0.50
C	0.90	1.30	c	0.10	0.20
L1	2.60	3.00	b	0.35	0.55
E	1.80	2.00	F	0	0.15

Note:

- 1) All dimensions are in millimeters.
- 2) Package length does not include mold flash, protrusion or gate burr.
- 3) Package width does not include inter lead flash or protrusion.
- 4) Lead popularity (bottom of leads after forming) shall be 0.10 millimeters max.
- 5) Pin 1 is lower left pin when reading top mark from left to right.

TAPE AND REEL INFORMATION

TAPE DIMENSIONS: SOT23-6

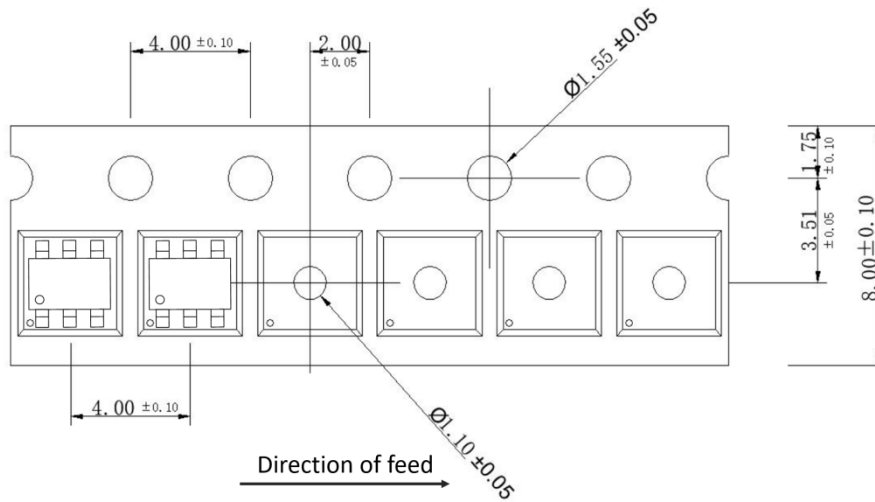

REEL DIMENSIONS: SOT23-6

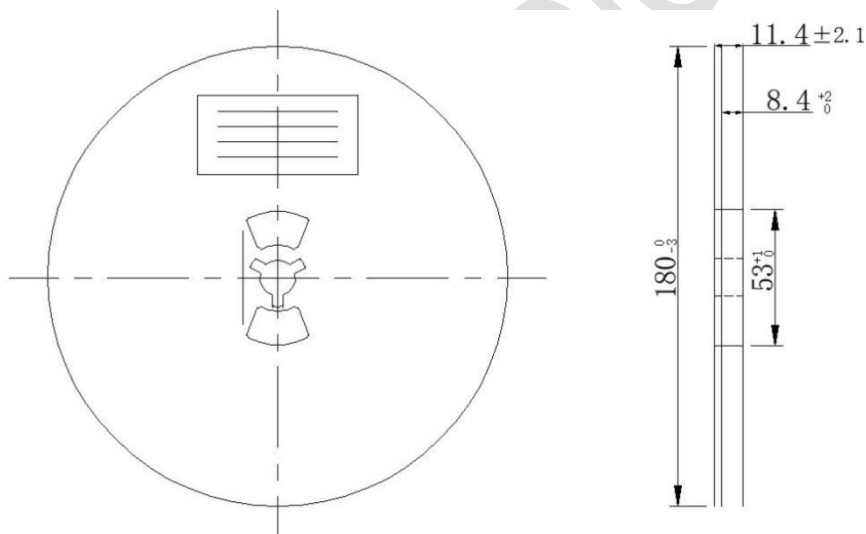

Note:

- 1) All Dimensions are in Millimeter
- 2) Quantity of Units per Reel is 3000
- 3) MSL level is level 3.