

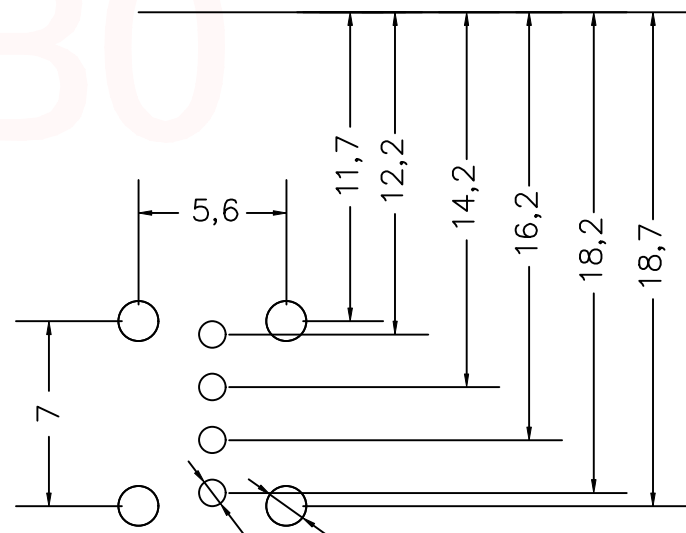

REV.	ECN NO OR DESCRIPTION	REVISED	DATE

- NOTES:
- MATERIAL SPECIFICATION
 - INSULATION MATERIAL THERMOPLASTIC.
 - SHELL: COPPER ALLOY/SPCC, T: 0.30mm
PLATING: NICKEL
 - TERMINAL: COPPER ALLOY, T: 0.25mm
PLATING: GOLD/TIN PLATED.
 - ELECTRICAL CHARACTERISTIC:
 - INSULATION RESISTANCE: 1000MΩ MIN.
 - CONTACT RESISTANCE: 30mΩ MAX.
 - WITHSTANDING VOLTAGE: 500V AC.
 - MECHANICAL CHARACTERISTICS:
 - INSERTION FORCE: 3.57Kgf MAX.
 - EXTRACTION FORCE: 1.02Kgf MIN.
- ORDERING INFORMATION

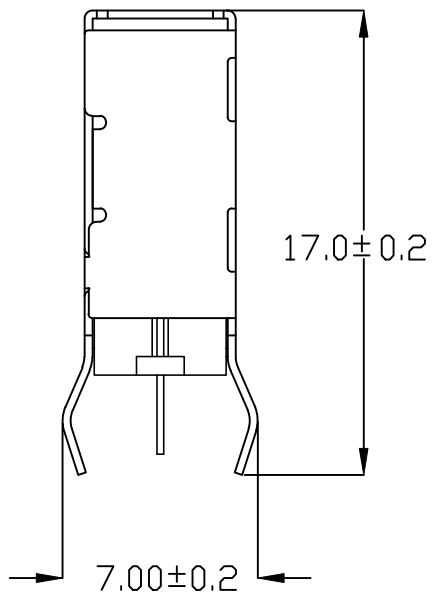
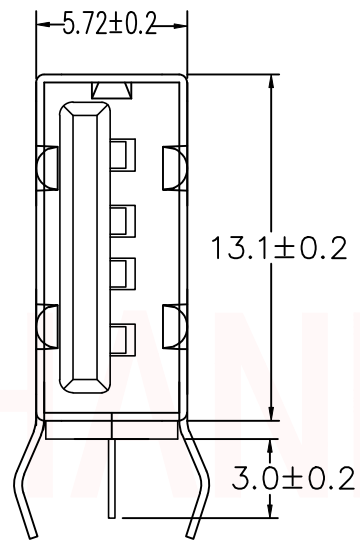
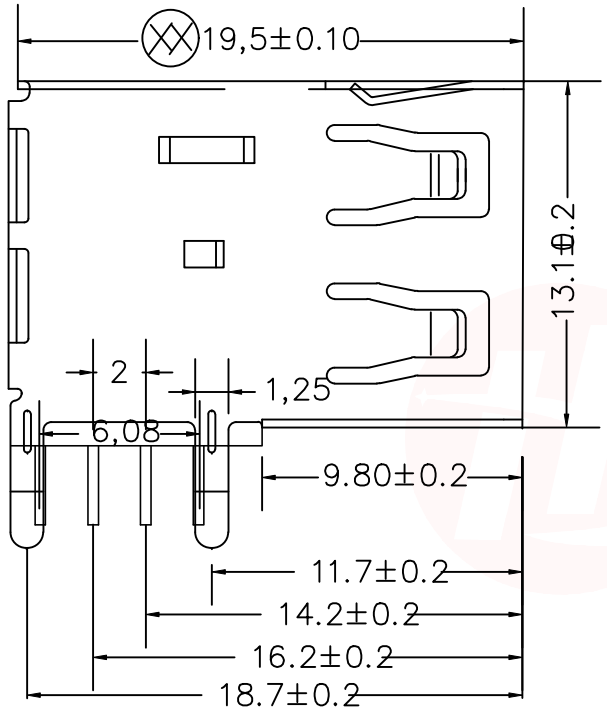

P.C.B 参照 ↗ 4-1.5

UNLESS OTHERWISE SPECIFIED TOLERANCES		东莞市汉博电子科技有限公司 DONGGUAN HANBO TECHNOLOGY CO., LTD			
DECIMALS:	ANGLES:	TITLE	USB 侧插长体19.6无卷边		
X : ±0.30	X : ±2°	DWN	xiong	PART NO. USB-U263-BWS	
X.X : ±0.20	X.X : ±1°	CHKD	lee	SCALE: 1:1	UNIT: mm
X.XX : ±0.10		APVD	wang	SIZE: A4	SHEET: 1 OF 1
		REV: A4			
CUSTOMER COPY					