

产品参数/Product parameters

额定电流 (Rated current): 50mA @ 12 VDC

寿命实验 (Life Test): 100,000 cycles typical

接触电阻 (Contact Resistance): 100Ω max.

绝缘电阻 (Insulation Resistance): 100MΩ min.

按键行程 (Key stroke): 0.25±0.10mm

驱动力 (Actuation Force): 100gf, 160gf, 260gf

工作温度 (Operating Temperature): -20° C to 70° C

介电强度 (Dielectric Strength): AC 250V 50HZ 1 minute

存储温度 (Storage Temperature): -30° C T0+80° C

最小包装 (Minimum package): 1000PCS (散装)

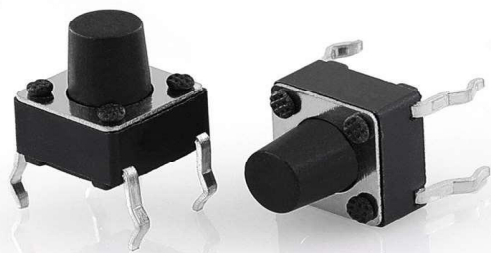

产品名称 Product name

- ▶ 6*6插件
- ▶ 6 * 6 plug-in

产品应用场景 Product application scenario

- ▶ 电子通讯/数码产品/家用电器
- ▶ 外围设备/汽车/医疗设备等.
- ▶ Electronic communication/digital products/household appliance peripherals/AuTomobile/medical equipment, etc

材质/MATERIALS:

No.	名称/NAME	材料/MATERIAL	工艺/Workmanship
①	按钮 Button	Nylon	黑色 Black
②	盖板 Cover plate	SPCC	镀镍 Plate with nickel
③	底座 Base	Nylon	黑色 Black
④	弹片 Shrapnel	F. Ag/C5210	镀银 Plate with silver
⑤	端子 Terminal	Brass	镀银 Plate with silver

产品高度/Product height:

产品高度/Product height			
Code	H	Code	H
43	4.3	110	11.0
45	4.5	115	11.5
50	5.0	120	12.0
55	5.5	125	12.5
60	6.0	130	13.0
65	6.5	135	13.5
70	7.0	140	14.0
75	7.5	145	14.5
80	8.0	150	15.0
85	8.5	155	15.5
90	9.0	160	16.0
95	9.5	165	16.5
100	10.0	170	17.0
105	10.5

产品编号/Product No

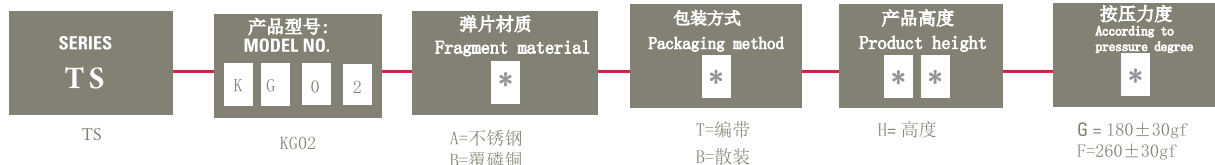

产品订购号示意图/Schematic diagram of product order number

Schematic diagram of product order number: TS-KG02-AB43F

产品外形尺寸图/Outline dimension drawing of product

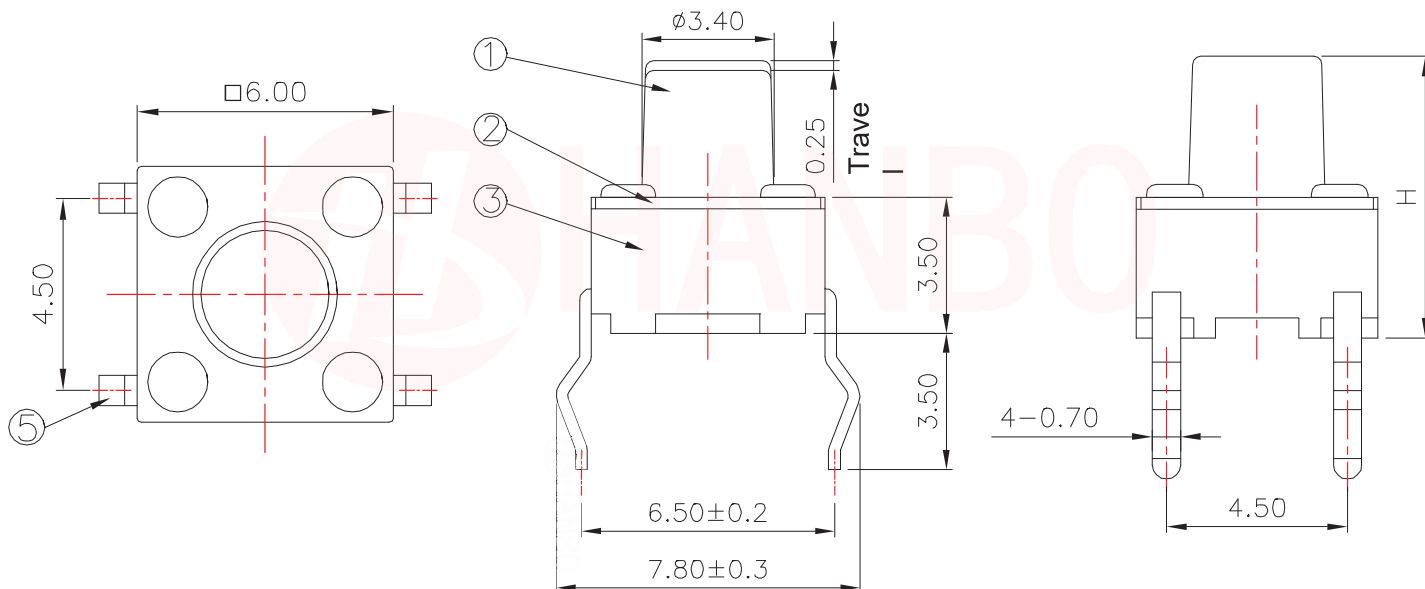

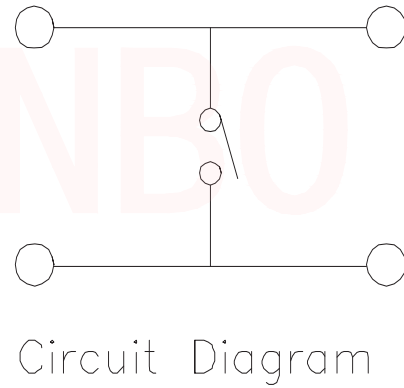
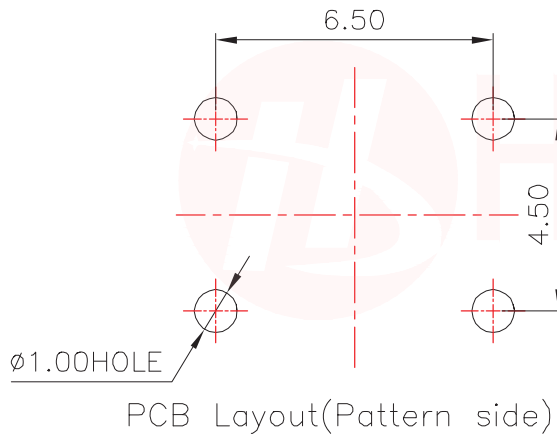

▶ ▶ ▶ 焊接条件/Welding conditions

■ 回流焊时/During reflow soldering

适用于表面贴装型温度分布/Applicable to surface mount temperature distribution

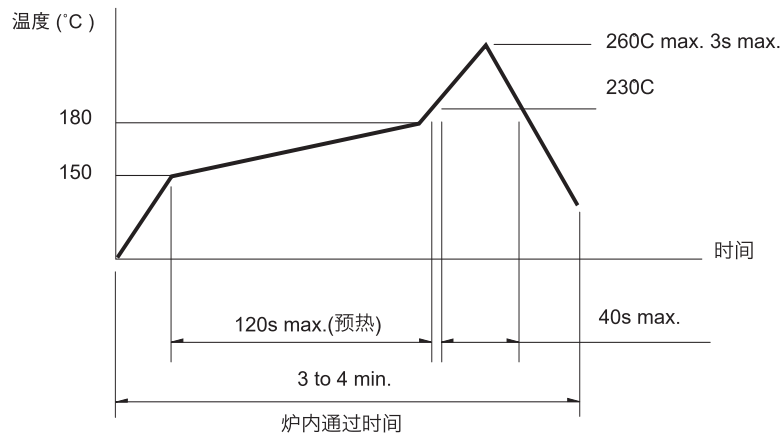

注/notes

- 关于详细条件，请于本公司的产品规格书进行确认。
Please confirm the detailed conditions in our product specification
- 根据贴面焊槽的种类，条件不同结果不同，请事先充分进行确认之后使用。
According to the type of veneer welding groove and different conditions, the results are different. Please fully confirm before using.

■ 自动浸焊式/Automatic dip welding

项目	条件
助焊剂附着量	不附着于零部件贴装面的程度
预热温度	印刷电路板焊接面的周围温度 100°C max.
预热温度时间	60s max.
焊接温度	260°C max.
焊接浸渍时间	5s max.
焊接次数	2 times max.

注/notes

- 请不要从轻触开关上面浸入助焊剂。
Do not immerse the flux on the touch switch
- 请不要事前在开关端子及印刷电路板的零部件贴装面上涂助焊剂。
Please do not apply flux on the mounting surface of switch terminals and printed circuit board components in advance
- 进行第 2 次焊接时，应在开关回复到常温之后进行。
The second welding shall be carried out after the switch returns to normal temperature.

■ 手焊式/Hand welded

项目	条件
焊接温度	350°C max.
焊接浸渍时间	3s max.
焊剂斗容量	60W max.