

SAW Single Filter

for GPS / GLONASS / BEIDOU / GALILEO / Unbalanced / 5pin / 1109

- **Small Size 1.1 x 0.9 mm**
- **Low Insertion Loss**
- **Good Attenuations in Cellular Bands**

1 Description

SAWF11091G56AT is a high-performance Surface Acoustic Wave (SAW) Bandpass filter optimized for GPS / GLONASS / BEIDOU / GALILEO applications operating in the range of 1.55905 GHz to 1.60566 GHz. It is designed to provide both low insertion loss in GPS / GLONASS / BEIDOU / GALILEO and high rejection in the adjacent cellular Bands for mobile devices.

SAWF11091G56AT uses advanced Chip Scale Package (CSP) technology and is housed in an industry-standard, 5-pin 1.1mm x 0.9mm package with a low profile of 0.6mm max.

2 Features

- Low Insertion Loss
- Small Footprint: $0.25 \pm 0.03\text{mm} \times 0.20 \pm 0.03\text{mm}$.
- Package size $1.1 \pm 0.05\text{mm} \times 0.9 \pm 0.05\text{mm}$
- Electrostatic Sensitive Device(ESD)
- Package height 0.6mm max.
- Single-Ended Operation
- RoHS Compliant

3 Package & Dimensions:

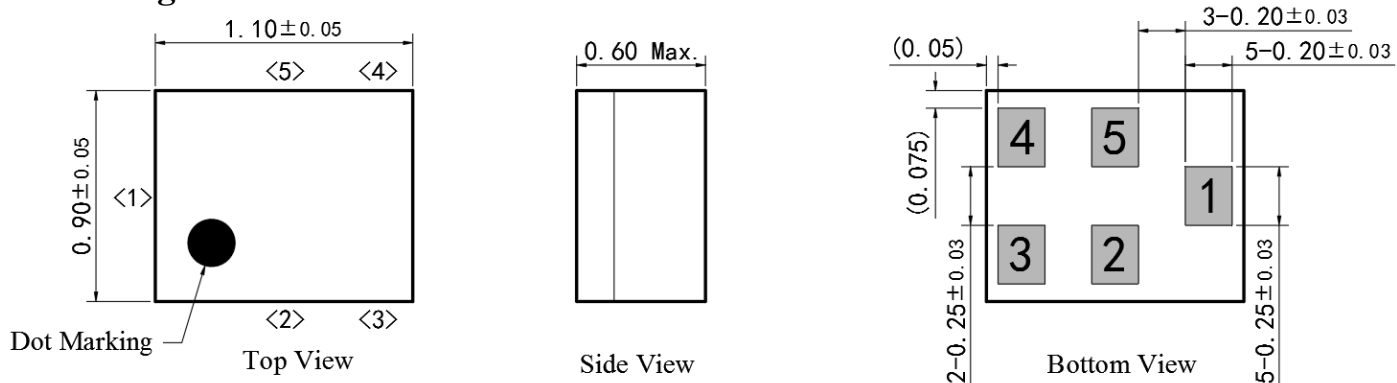


Figure 1: Drawing of Package with each tolerance range

4 Pin configuration

- 1 Input (recommended)
- 4 Output (recommended)
- 2,3,5 To be grounded

5 Matching Circuit(recommended)

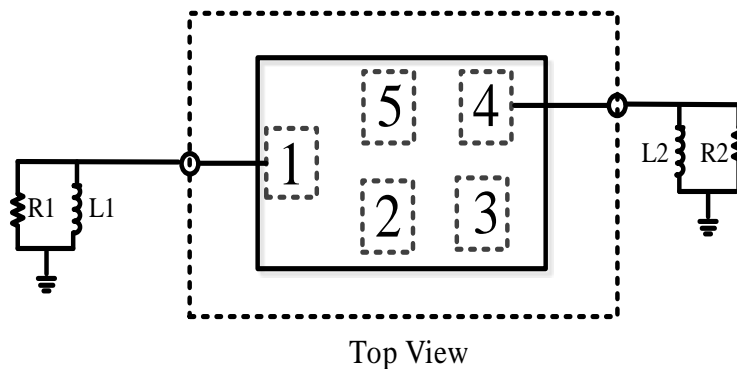


Figure 2: Schematic of matching circuit.

R1: 50 Ohm	L1: NC
R2: 50 Ohm	L2: NC

6 Absolute Maximum Ratings

Parameter	Rating	Unit
Operating Temperature	-30 to +85	°C
Storage Temperature	-40 to +85	°C
Maximum Input Power	+15	dBm
Maximum DC Voltage	5	V

7 Electrical Specifications

(At $T_a=25^{\circ}\text{C}$, unless otherwise specified, as measured on the evaluation board of SAWF11091G56AT with feed line loss de-embedded.)

Parameter	Conditions	Min	Typ.	Max	Unit	Note
Insertion Loss	1559.05 - 1563.15 MHz	-	1.5	1.8	dB	
	1574.39 - 1576.45 MHz	-	1.3	1.7	dB	
	1597.78 - 1605.66 MHz	-	1.4	1.7	dB	
Passband Ripple	1559.05 - 1563.15 MHz	-	0.2	0.5	dB	
	1574.39 - 1576.45 MHz		0.2	0.5	dB	
	1597.78 - 1605.66 MHz		0.2	0.5	dB	
Attenuation	824 - 925 MHz	36	45	-	dB	
	1710 - 1785 MHz	37	45	-	dB	
	1850 - 1980 MHz	37	48	-	dB	
	2400 - 2570 MHz	40	42	-	dB	
VSWR Input	1559.05 - 1563.15 MHz	-	1.4	1.7	-	
	1574.39 - 1576.45 MHz	-	1.2	1.6	-	
	1597.78 - 1605.66 MHz	-	1.2	1.6	-	
VSWR Output	1559.05 - 1563.15 MHz	-	1.4	1.6	-	
	1574.39 - 1576.45 MHz	-	1.2	1.6	-	
	1597.78 - 1605.66 MHz	-	1.3	1.7	-	

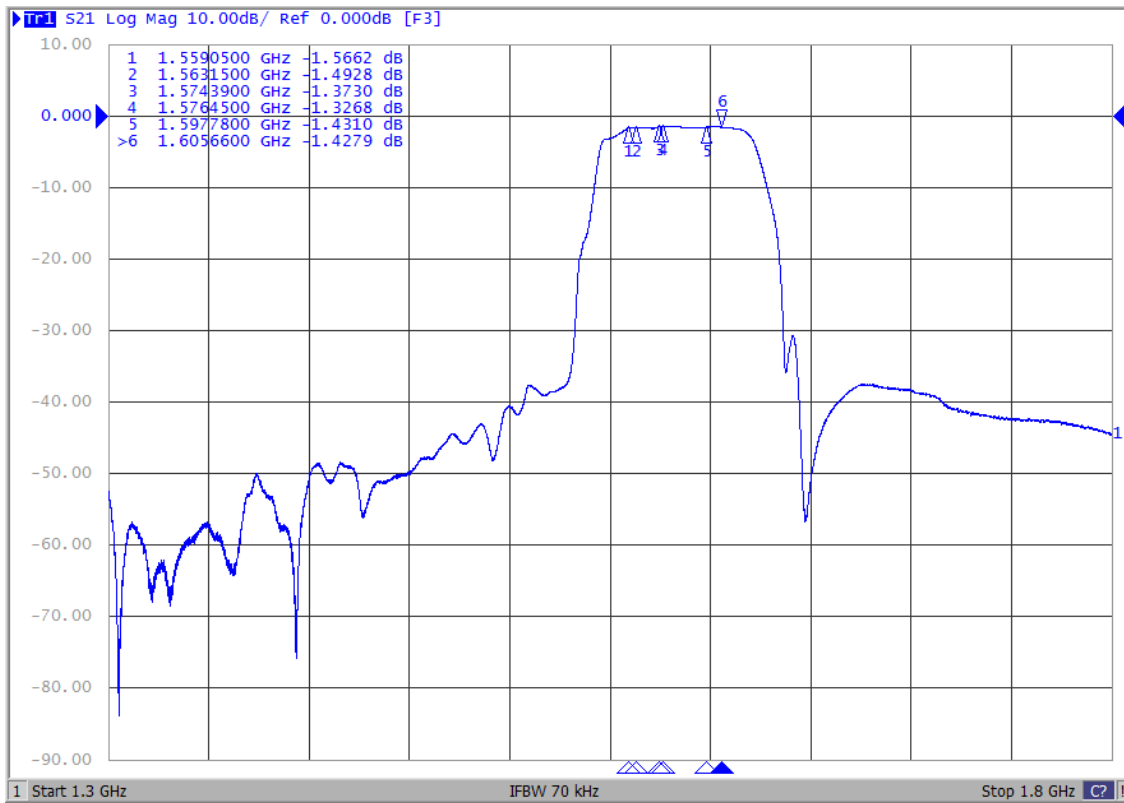
8 Transmission coefficient


Figure 3: |S21|

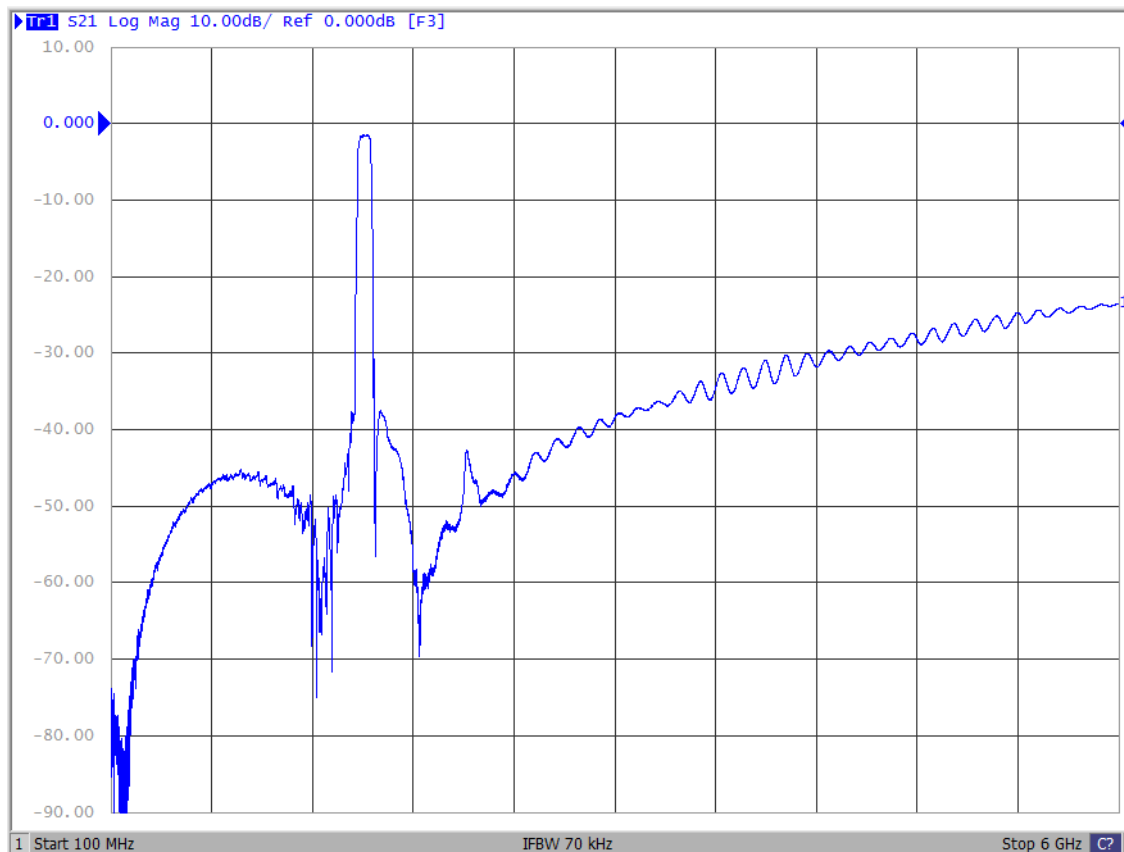


Figure 4: Wide Band |S21|

9 Reflection coefficients

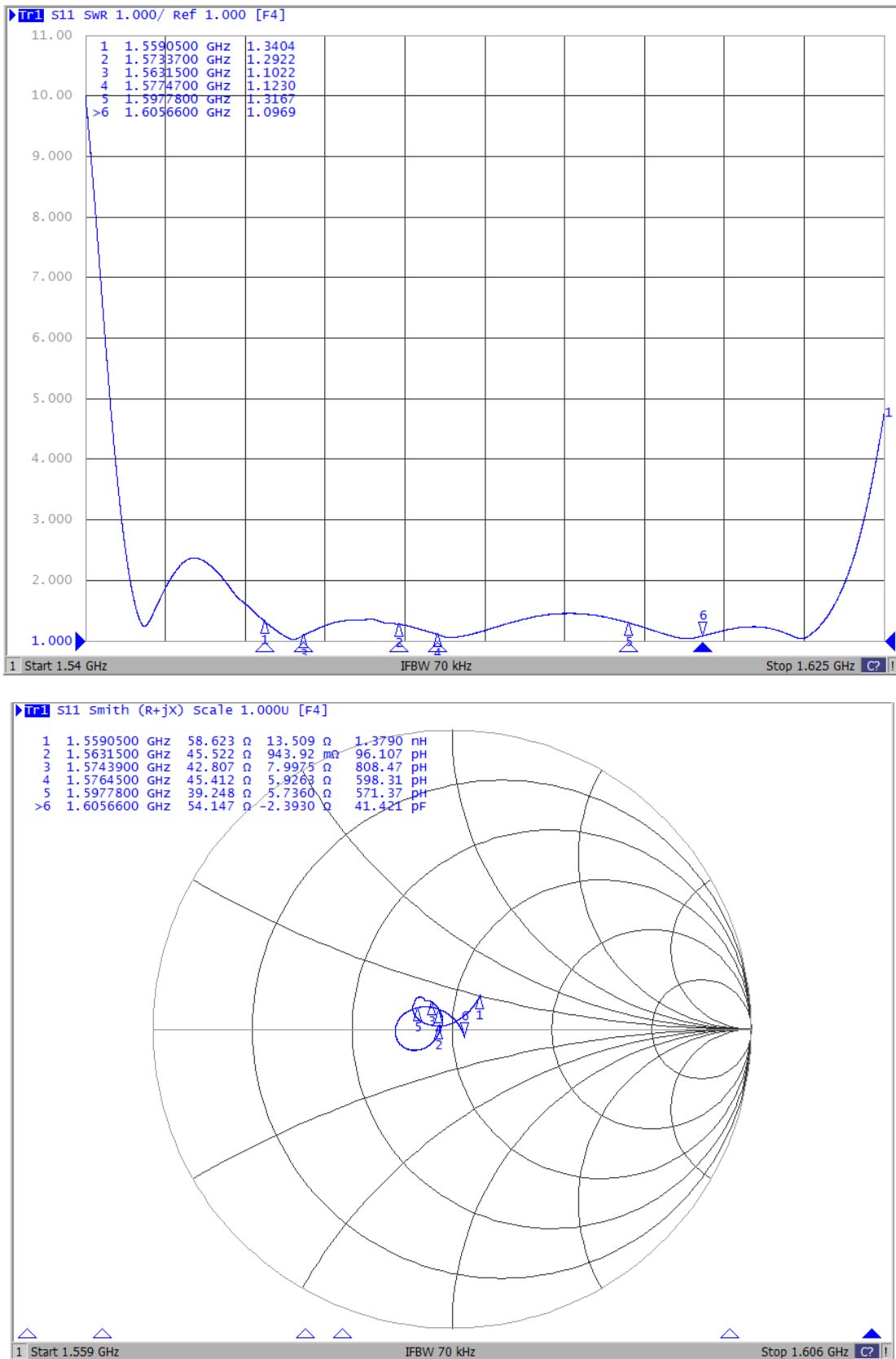


Figure 5: Reflection coefficient for S11

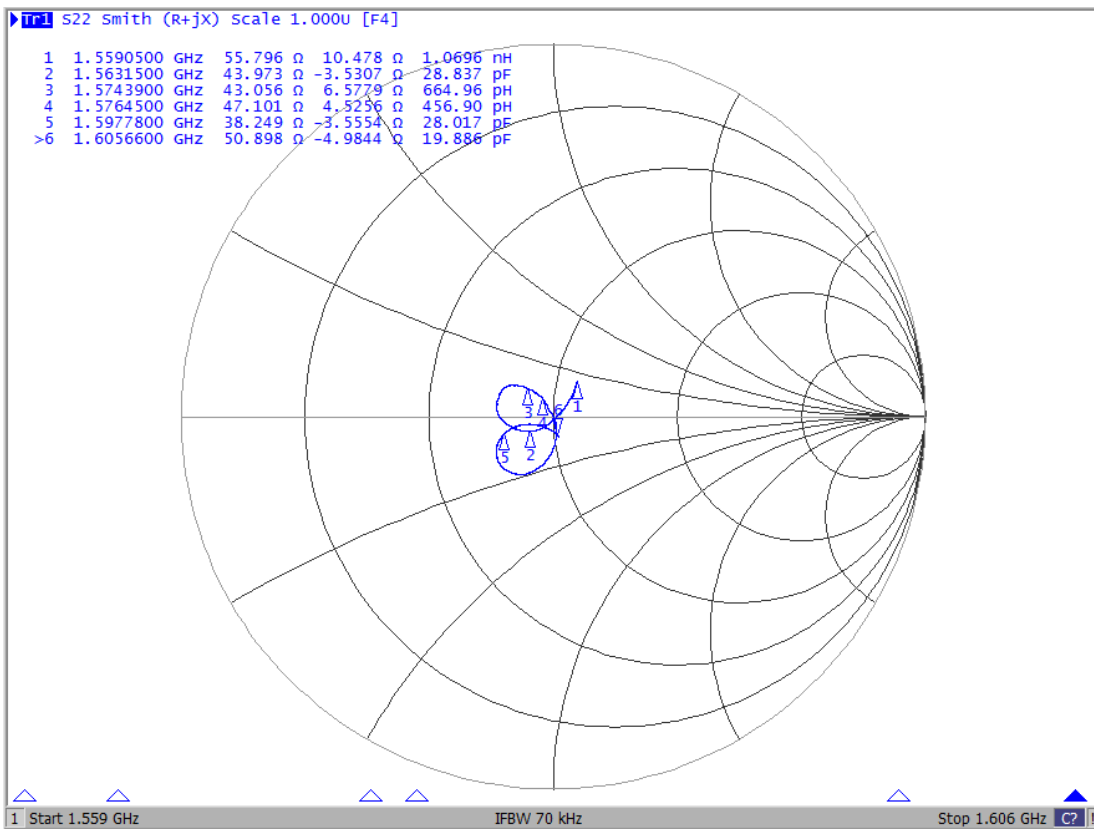
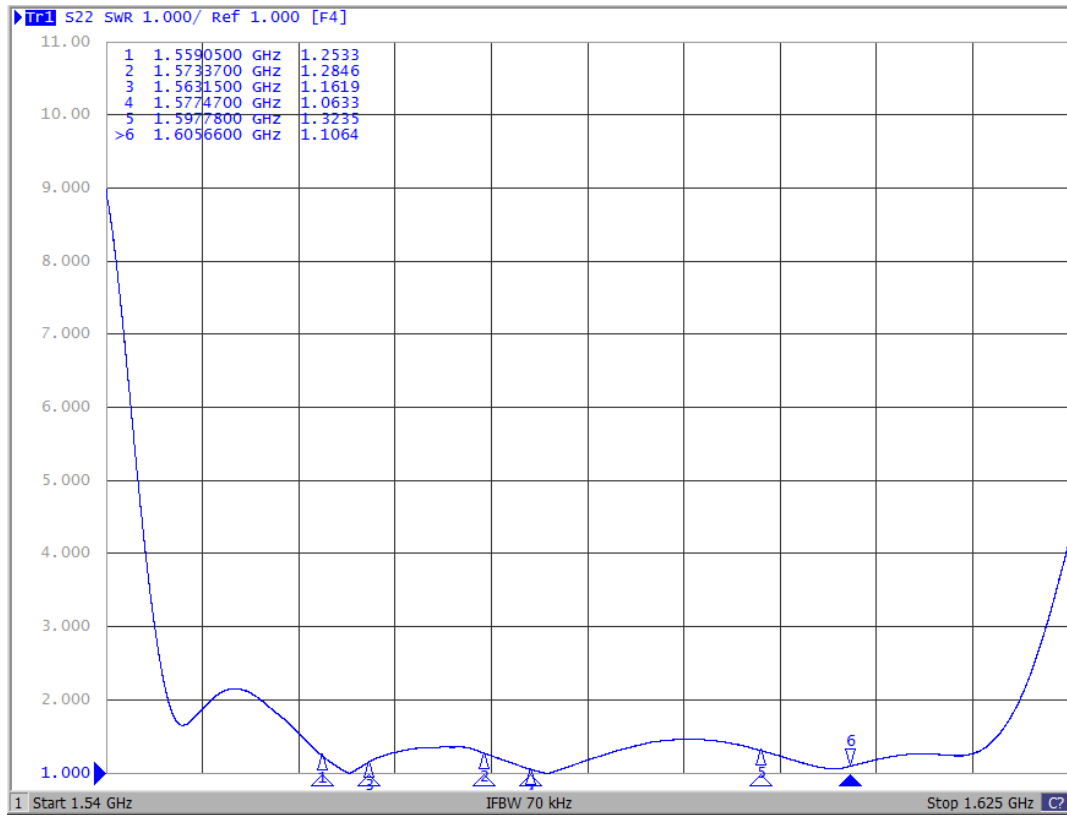


Figure 6: Reflection coefficient for S22

10 Packing material

10.1 Tape

Tensile Strength of Carrier Tape: Carrier tape 10N or more; Cover tape 5N or more. Packaging quantities: 5000 PCS / Reel.

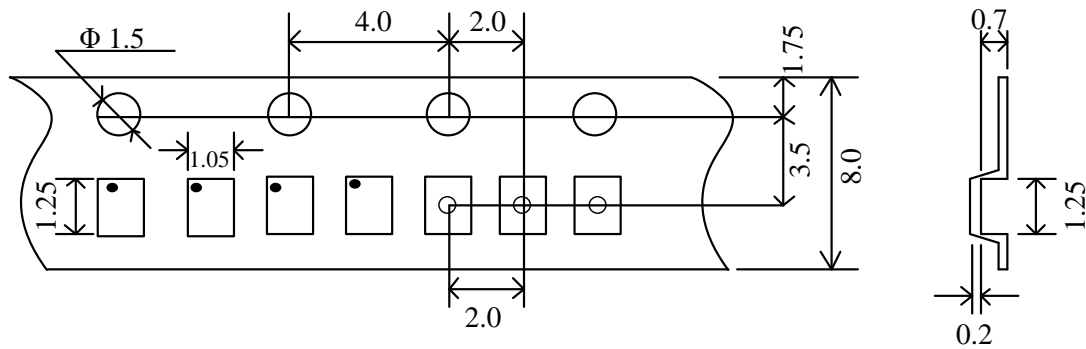


Figure 7: Drawing of tape with tape dimensions according above.

10.2 Reel with diameter of 178mm

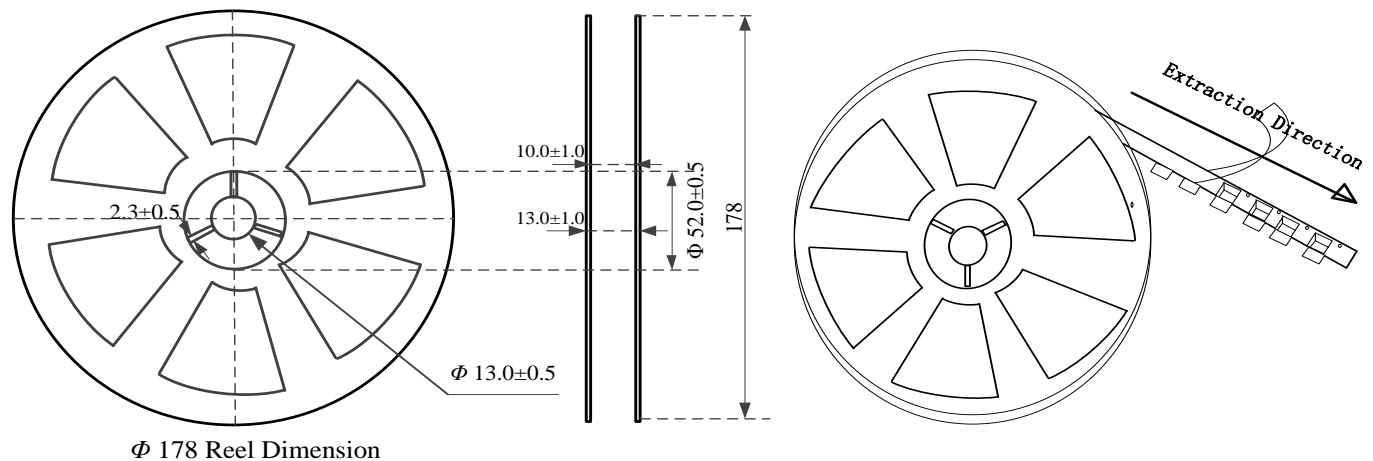


Figure 8: Drawing of reel with diameter of 178mm.