

REV	LOCALS	DESCRIPTION	DRAW	DATE
A0	NEW	PERLIMINARY	Andy	2022.07.21

- NOTES:
- MATERIAL:
    - Housing: High Temperature Thermoplastic UL94V-0; Color Black.
    - Terminal: Copper Alloy.
  - FINISH:
    - Terminal: Plated Tin 80U" Min Over All. Underplated Nickel 50U" Over all.
  - SPECIALITY:
    - Rated current: 5A
    - Rated voltage: 250VAC/DC
    - Contact Resistance: 10mΩ MAX
    - Insulation Resistance: 1000MΩ MIN 100V DC
    - Dielectric withstanding voltage: 1500VAC/Minute.
    - Salt Spray Test: 24Hours.

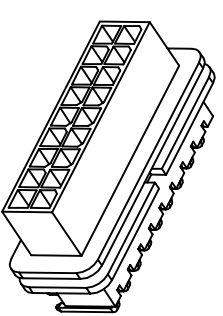
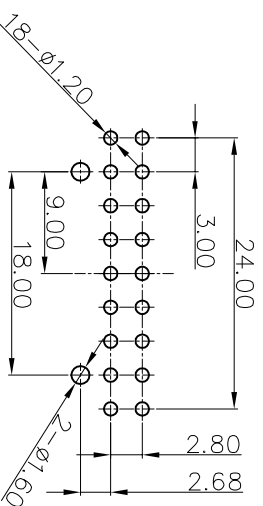
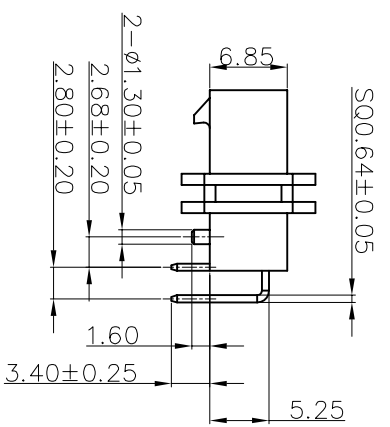
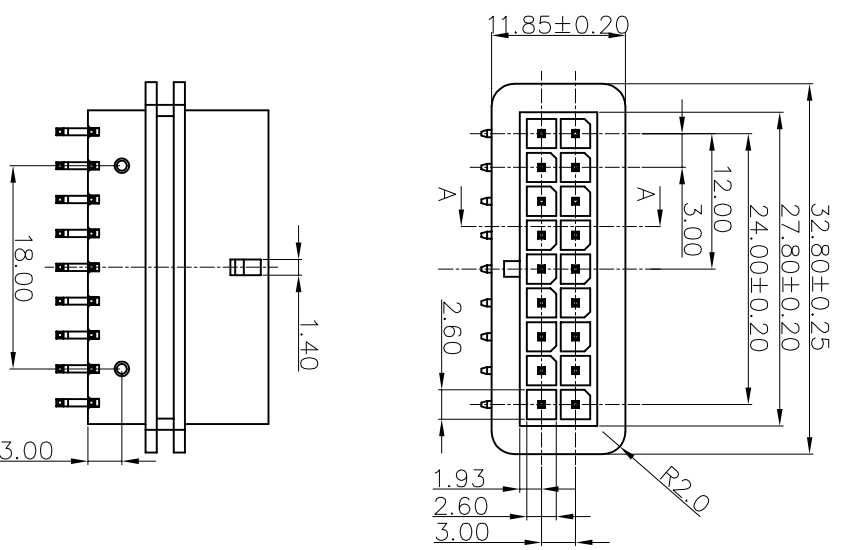
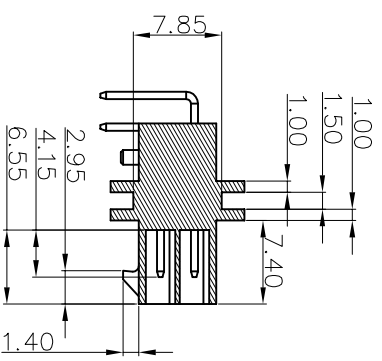
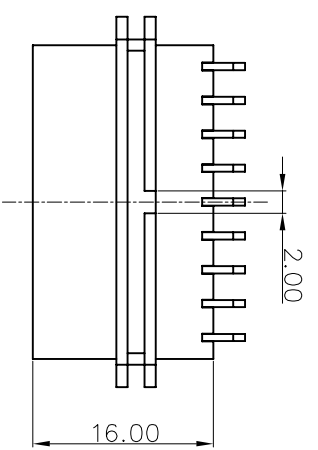

MEASURE POINT: (QP) (TP) (P)

QUADRANT POINT

TANGENCY POINT

INTERSECTION POINT

UNLESS OTHERWISE SPECIFIED, TOLERANCE:

X	±0.35
X.x	±0.25
X.xx	±0.15
ANGULAR	±3'

 Dongguan D-CHAIN Precision Components Co., Ltd		DESIGN	Andy	DATE	2022.07.21	TITLE:	18PIN 6.85H 3.0PITCH WAFER DIP TYPE
		CHECKED		DATE			
		APPROVED		DATE		REV: A0	SCALE: 1:1
		PART NO:	WA1812300685-21B	REV: A0		UNIT:	mm
		DRAWING NO:		SIZE: A4		SHEET: 1/1	