

REV	LOCALS	DESCRIPTION	DRAW	DATE
01	NEW	新增规格 (规格发生变更时)	Andy	2020.07.20
02	△	UPDATING	Andy	2022.06.15

NOTES:

- MATERIAL:
 - Housing: High Temperature Thermoplastic UL94V-0; Color Black.
 - Terminal: Copper Alloy, T=0.12MM.
 - Shell: Stainless Steel, T=0.15MM.
- FINISH:
 - Terminal: Plated Gold on the Contact Area and Solder Tails, Underplated Nickel Over all.
 - Shell: Plated Gold on the Solder Tails, Underplated Nickel Over all.
- SPECIALTY:
 - Rated current: 1.0A
 - Rated voltage: 30V
 - Contact Resistance: 50mΩ MAX
 - Insulation Resistance: 100MΩ MIN 100V DC
 - Dielectric withstanding voltage: 100V AC.
 - Solder ability: 245±5°C, 5±0.5s.
 - Durability: 5000 Cycles Min.

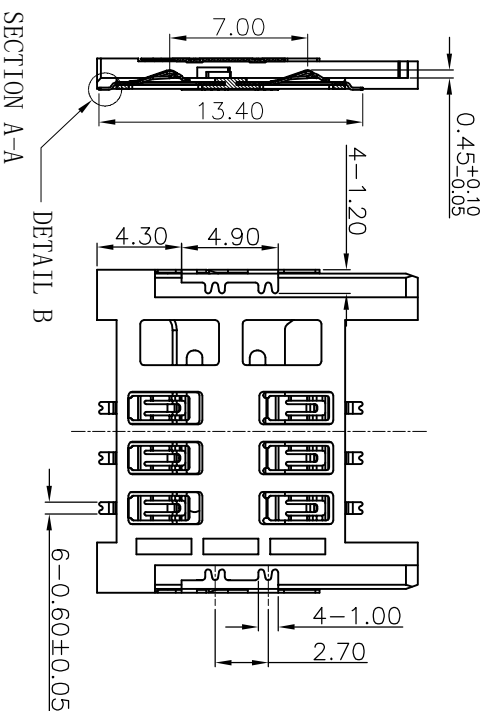

DETAIL B
SCALE 4:1
ALL SOLDER TAILS

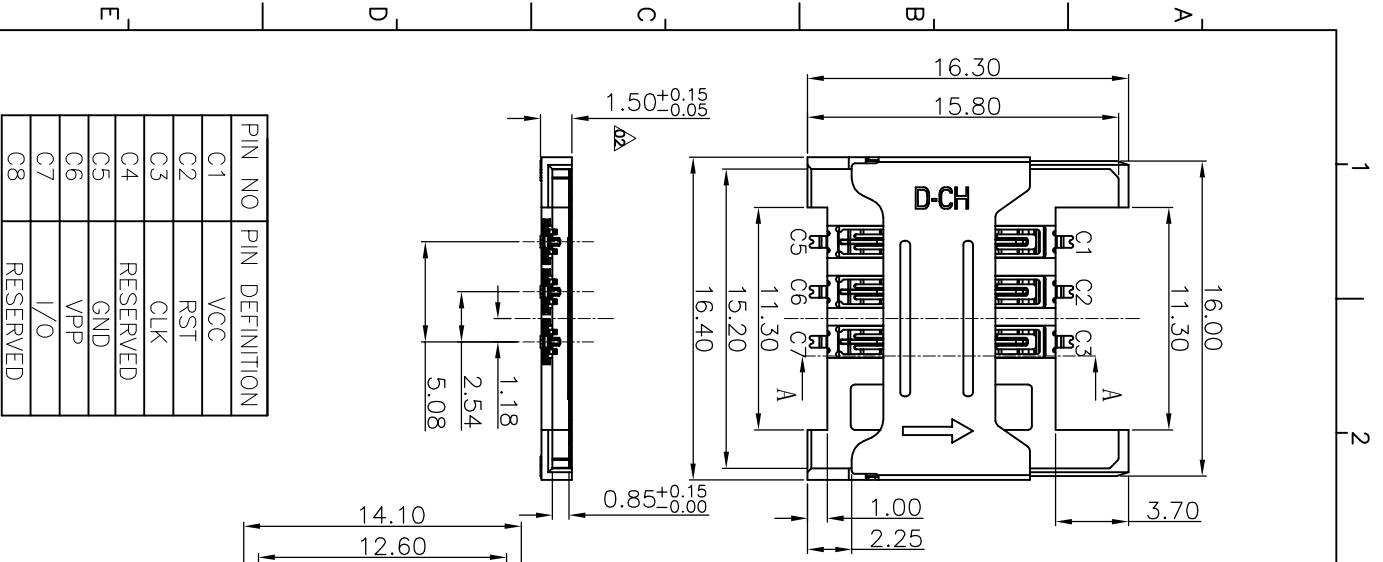
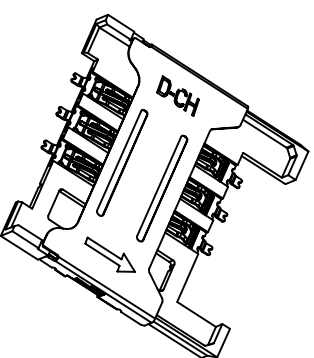

PIN NO	PIN DEFINITION
C1	VCC
C2	RST
C3	CLK
C4	RESERVED
C5	GND
C6	VPP
C7	I/O
C8	RESERVED

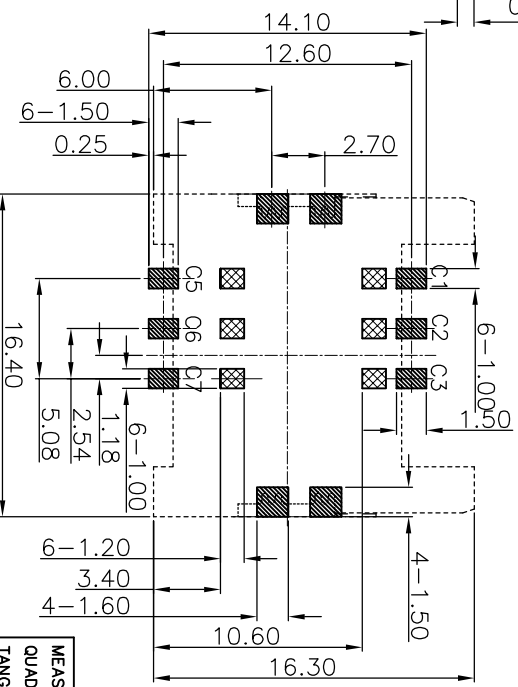

RECOMMEND P.C.B. LAYOUT
TOLERANCE ±0.05

THESE AREA SHOULD BE FREE OF ANY CONDUCTIVE TRACES
SMT SOLDER AREA



Dongguan D-CHAIN Precision Components Co., Ltd

MEASURE POINT:	Ⓢ
QUADRANT POINT	Ⓢ
TANGENCY POINT	Ⓢ
INTERSECTION POINT	Ⓢ
UNLESS OTHERWISE SPECIFIED, TOLERANCE:	
X	±0.25
X.x	±0.20
X.xx	±0.15
ANGULAR	±3°

DESIGN	Andy	DATE	2020.07.20	TITLE:	1.5H 6P IN SLM CARD防浪PIN
CHECKED		DATE			
APPROVED		DATE			
PART NO:	SM0602254150-63-03	REV:	02	SCALE:	1:1
DRAWING NO:		SIZE:	A4	SHEET:	1/1

UNIT: mm