

## Low-power CMOS dual operational amplifiers

The HT27M2 series are low-cost and low-power dual operational amplifiers designed to operate with high-voltage single or dual supplies.

CMOS process, providing an excellent consumption-speed ratio thanks to three different power consumptions, making them ideal for low-consumption applications:

$I_{CC} = 10 \mu\text{A}/\text{amp}$ : HT27M2A (very low power),

$I_{CC} = 150 \mu\text{A}/\text{amp}$ : HT27M2B (low power) and

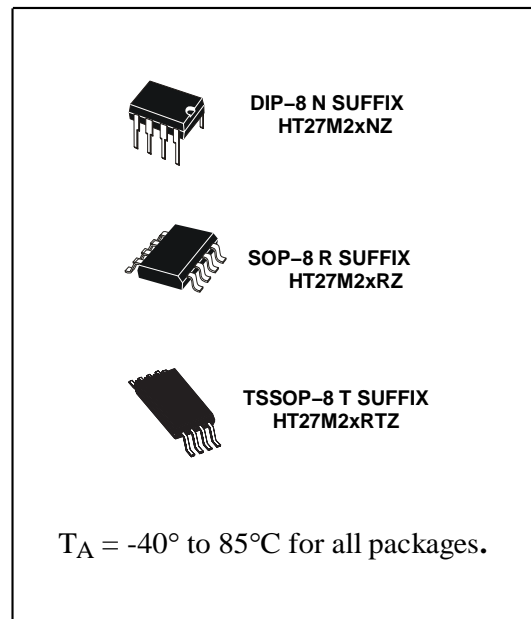
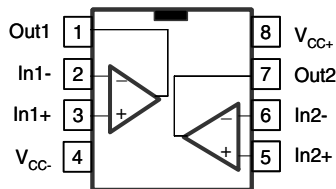
$I_{CC} = 1 \text{mA}/\text{amp}$ : HT27M2C (high speed)

The devices also offer a very high input impedance and extremely low input currents. Their main advantage compared to JFET devices is the very low input current drift with temperature

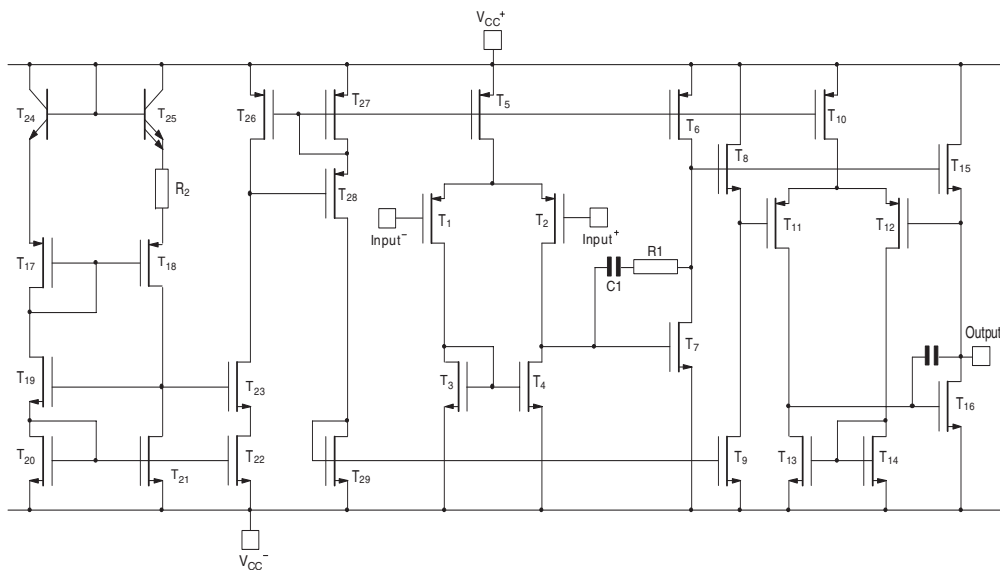
### Features

- Wide supply voltage range: 1.5 to 10 V
- Ultra-low consumption: 150  $\mu\text{A}/\text{op}$  typ
- Output voltage swing to ground
- Excellent phase margin on capacitive load
- Gain bandwidth product: 1 MHz typ
- $V_{io}$  down to 2 mV max. (B version)

### Pin connections (top view)



### Simplified schematic diagram (for 1/2 HT27M2)



## Absolute maximum ratings and operating conditions

**Table 1. Absolute maximum ratings**

Symbol	Parameter	HT27M2A/B/C	Unit
$V_{CC}^+$	Supply voltage <sup>(1)</sup>	10	V
$V_{id}$	Differential input voltage <sup>(2)</sup>	±5	V
$V_i$	Input voltage <sup>(3)</sup>	-0.3 to 10	V
$I_o$	Output current for $V_{CC}^+ \geq 10V$	±5	mA
$I_{in}$	Input current	±5	mA
$R_{thja}^{(4)(5)}$	SO-8	125	°C/W
	DIP8	85	
	TSSOP8	120	
$T_{stg}$	Storage temperature range	-65 to +150	°C
$T_j$	Maximum junction temperature	150	°C
ESD	HBM: human body model <sup>(6)</sup>	500	V
	MM: machine model <sup>(7)</sup>	100	V
	CDM: charged device model <sup>(8)</sup>	1.5	kV

1. All values, except differential voltage are with respect to network ground terminal.
2. Differential voltages are the non-inverting input terminal with respect to the inverting input terminal.
3. The magnitude of the input and the output voltages must never exceed the magnitude of the positive supply voltage.
4. Short-circuits can cause excessive heating and destructive dissipation.
5.  $R_{th}$  are typical values.
6. Human body model: a 100 pF capacitor is charged to the specified voltage, then discharged through a 1.5 kΩ resistor between two pins of the device. This is done for all couples of connected pin combinations while the other pins are floating.
7. Machine model: a 200 pF capacitor is charged to the specified voltage, then discharged directly between two pins of the device with no external series resistor (internal resistor < 5 Ω). This is done for all couples of connected pin combinations while the other pins are floating.
8. Charged device model: all pins and the package are charged together to the specified voltage and then discharged directly to the ground through only one pin. This is done for all pins.

**Table 2. Operating conditions**

Symbol	Parameter	Value			Unit
		HT27M2A/B/C	HT27M2IA/IB/IC	HT27M2JA/JB/JC	
$V_{CC}^+$	Supply voltage	1.5 to 10			V
$V_{icm}$	Common mode input voltage range	0 to $V_{CC}^+ - 1.5$			V
$T_{oper}$	Operating free air temperature range	-40 to +85	-40 to +125	-55 to +125	°C

## 2 Electrical characteristics

**Table 3. Electrical characteristics at  $V_{CC+} = +10\text{ V}$ ,  $V_{CC-} = 0\text{ V}$ ,  $T_{amb} = +25^\circ\text{ C}$  (unless otherwise specified)**

Symbol	Parameter	HT27M2x			HT27M2J			Unit
		Min.	Typ.	Max.	Min.	Typ.	Max.	
<b>DC performance</b>								
$V_{io}$	Input offset voltage $V_O = 1.4\text{ V}$ , $V_{ic} = 0\text{ V}$		1.1	10			10	mV
			0.9	5		1.1	5	
			0.25	2		0.9	2	
	$T_{min} \leq T_{amb} \leq T_{max}$			12		0.25	12	
				6.5			6.5	
			3			3.5		
$DV_{io}$	Input offset voltage drift		2			2		$\mu\text{V}/^\circ\text{C}$
$I_{io}$	Input offset current <sup>(1)</sup> $V_{ic} = 5\text{ V}$ , $V_O = 5\text{ V}$		1			1		pA
	$T_{min} \leq T_{amb} \leq T_{max}$			100			200	
$I_{ib}$	Input bias current <sup>(1)</sup> $V_{ic} = 5\text{ V}$ , $V_O = 5\text{ V}$		1			1		pA
	$T_{min} \leq T_{amb} \leq T_{max}$			150			300	
$V_{OH}$	High level output voltage $V_{id} = 100\text{ mV}$ , $R_L = 100\ \Omega$	8.7	8.9		8.7	8.9		V
	$T_{min} \leq T_{amb} \leq T_{max}$	8.6			8.5			
$V_{OL}$	Low level output voltage $V_{id} = -100\text{ mV}$			50			50	mV
$A_{vd}$	Large signal voltage gain $V_{ic} = 5\text{ V}$ , $R_L = 100\text{ k}\Omega$ , $V_o = 1\text{ V to }6\text{ V}$	30	50		30	50		V/mV
	$T_{min} \leq T_{amb} \leq T_{max}$	20			10			
CMR	Common mode rejection ratio $V_{ic} = 1\text{ V to }7.4\text{ V}$ , $V_o = 1.4\text{ V}$	65	80		65	80		dB
SVR	Supply voltage rejection ratio $V_{CC+} = 5\text{ V to }10\text{ V}$ , $V_o = 1.4\text{ V}$	60	80		60	80		dB
$I_{CC}$	Supply current (per amplifier) $A_v = 1$ , no load, $V_o = 5\text{ V}$		150	200		150	200	$\mu\text{A}$
	$T_{min} \leq T_{amb} \leq T_{max}$			250			300	
$I_o$	Output short circuit current $V_o = 0\text{ V}$ , $V_{id} = 100\text{ mV}$	4	6			6		mA
$I_{sink}$	Output sink current $V_o = V_{CC-}$ , $V_{id} = -100\text{ mV}$	3	4			4		mA

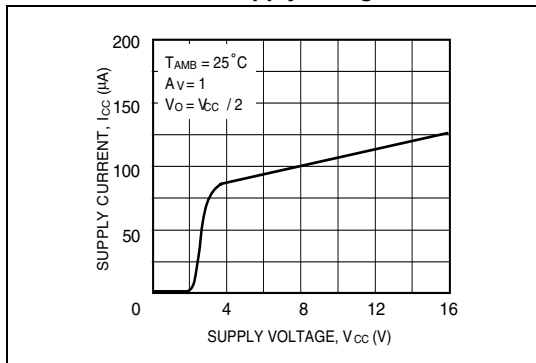
**Table 3. Electrical characteristics at  $V_{CC+} = +10\text{ V}$ ,  $V_{CC-} = 0\text{ V}$ ,  $T_{amb} = +25^\circ\text{ C}$   
 (unless otherwise specified) (continued)**

Symbol	Parameter	HT27M2x			HT27M2J			Unit
		Min.	Typ.	Max.	Min.	Typ.	Max.	
<b>AC performance</b>								
GBP	Gain bandwidth product $A_V = 40\text{ dB}$ , $R_L = 100\text{ k}\Omega$ , $C_L = 100\text{ pF}$ , $f_{in} = 100\text{ kHz}$	0.5	1		0.5	1		MHz
SR	Slew rate at unity gain $R_L = 100\text{ k}\Omega$ , $C_L = 100\text{ pF}$ , $V_i = 3\text{ to }7\text{ V}$	0.3	0.6		0.3	0.6		V/ $\mu\text{s}$
$\phi_m$	Phase margin at unity gain $A_V = 40\text{ dB}$ , $R_L = 100\text{ k}\Omega$ , $C_L = 100\text{ pF}$		45			45		Degrees
$K_{OV}$	Overshoot factor		30			30		%
$e_n$	Equivalent input noise voltage $f = 1\text{ kHz}$ , $R_s = 100\ \Omega$		38			38		$\frac{\text{nV}}{\sqrt{\text{Hz}}}$
$V_{O1}/V_{O2}$	Channel separation		120			120		dB

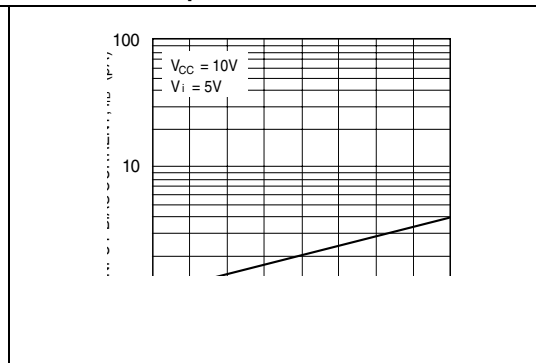
1. Maximum values including unavoidable inaccuracies of industrial tests.

### 3 Typical characteristics

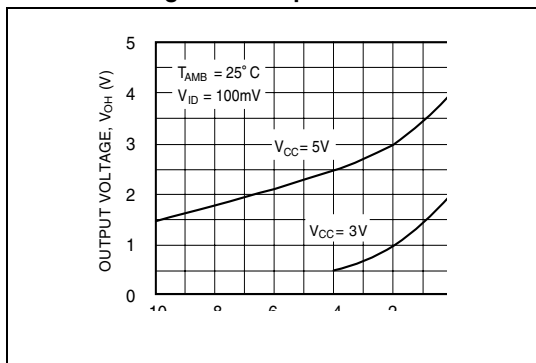
**Figure 2. Supply current (each amplifier) versus supply voltage**



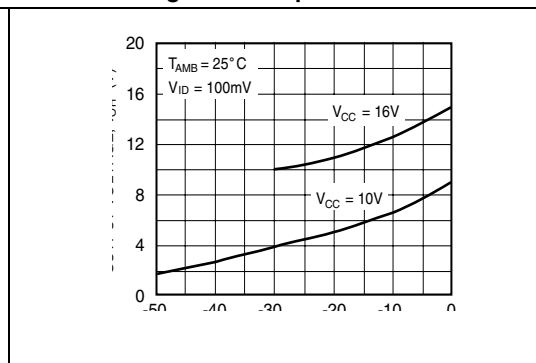
**Figure 3. Input bias current versus free air temperature**



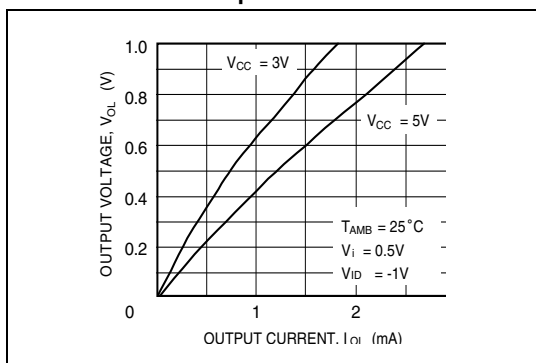
**Figure 4. High level output voltage versus high level output current**



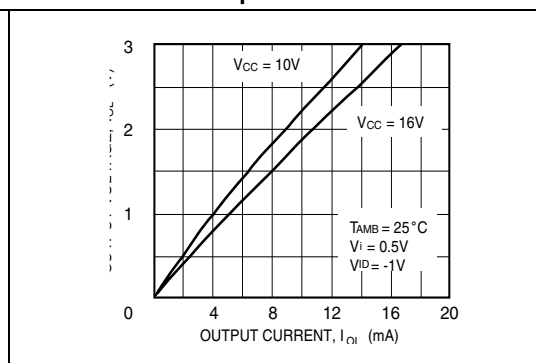
**Figure 5. High level output voltage versus high level output current**

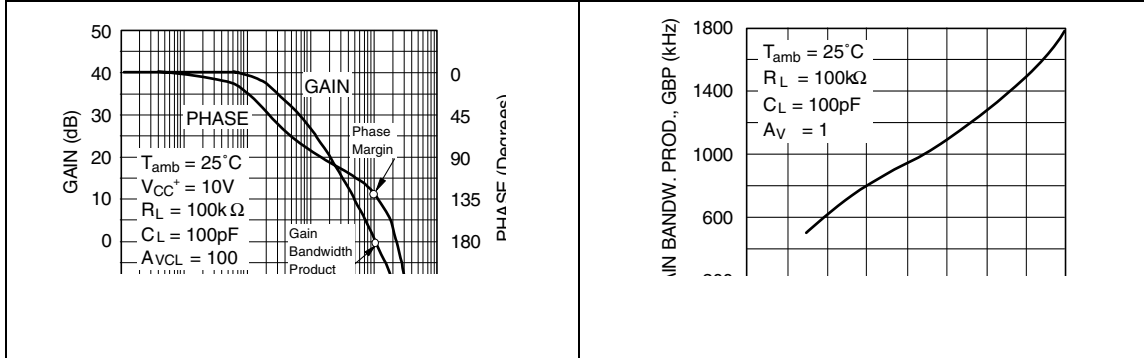
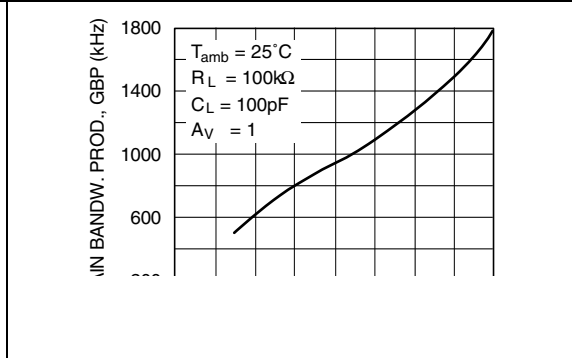
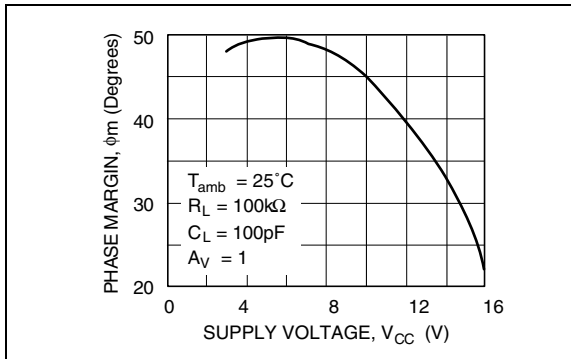
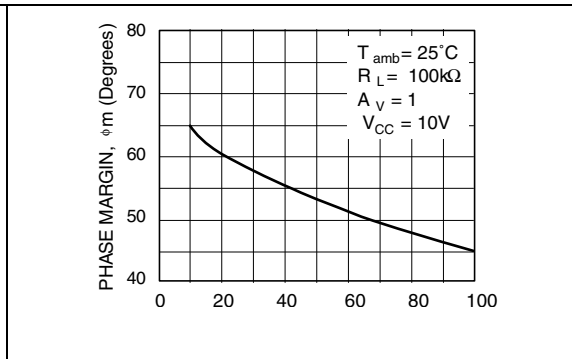
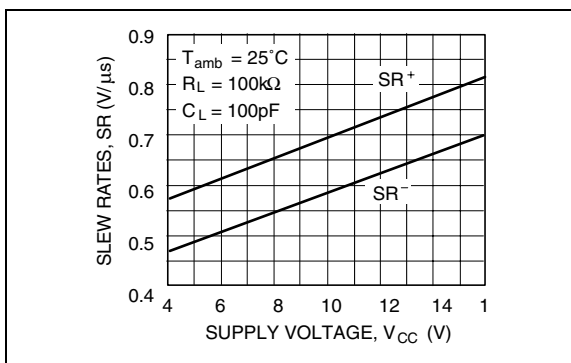
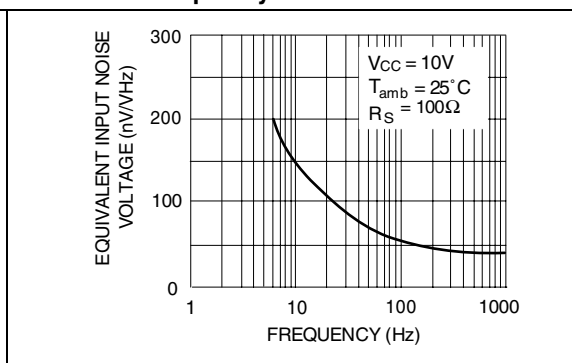


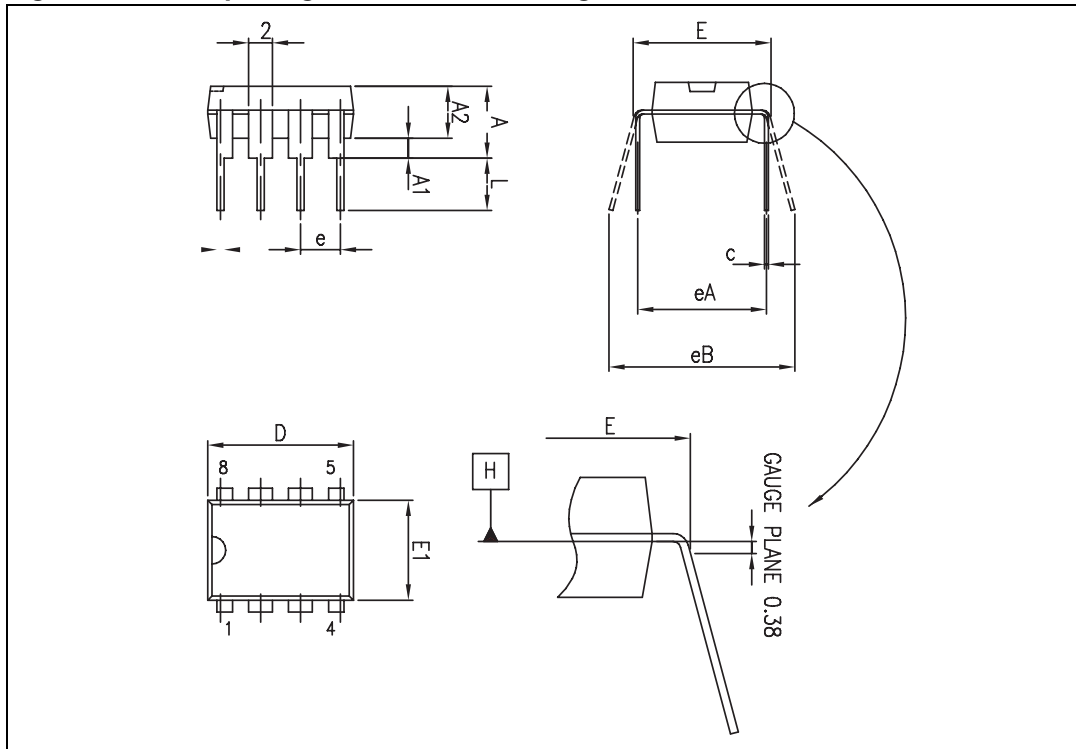
**Figure 6. Low level output voltage versus low level output current**



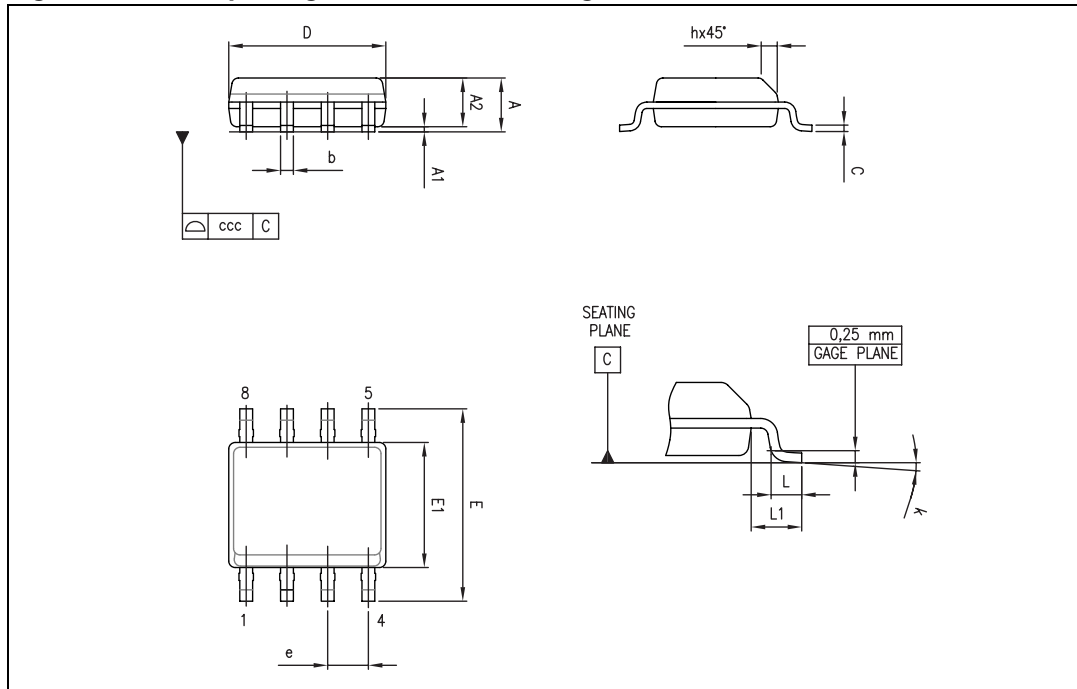
**Figure 7. Low level output voltage versus low level output current**



**Figure 8. Open-loop frequency response and phase shift**

**Figure 9. Gain bandwidth product versus supply voltage**

**Figure 10. Phase margin versus supply voltage**

**Figure 11. Phase margin versus capacitive load**

**Figure 12. Slew rate versus supply voltage**

**Figure 13. Input voltage noise versus frequency**


**DIP8 package information**
**Figure 14. DIP8 package mechanical drawing**

**Table 4. DIP8 package mechanical data**

Ref.	Dimensions					
	Millimeters			Inches		
	Min.	Typ.	Max.	Min.	Typ.	Max.
A			5.33			0.210
A1	0.38			0.015		
A2	2.92	3.30	4.95	0.115	0.130	0.195
b	0.36	0.46	0.56	0.014	0.018	0.022
b2	1.14	1.52	1.78	0.045	0.060	0.070
c	0.20	0.25	0.36	0.008	0.010	0.014
D	9.02	9.27	10.16	0.355	0.365	0.400
E	7.62	7.87	8.26	0.300	0.310	0.325
E1	6.10	6.35	7.11	0.240	0.250	0.280
e		2.54			0.100	
eA		7.62			0.300	
eB			10.92			0.430
L	2.92	3.30	3.81	0.115	0.130	0.150

**SO-8 package information**
**Figure 15. SO-8 package mechanical drawing**

**Table 5. SO-8 package mechanical data**

Ref.	Dimensions					
	Millimeters			Inches		
	Min.	Typ.	Max.	Min.	Typ.	Max.
A			1.75			0.069
A1	0.10		0.25	0.004		0.010
A2	1.25			0.049		
b	0.28		0.48	0.011		0.019
c	0.17		0.23	0.007		0.010
D	4.80	4.90	5.00	0.189	0.193	0.197
E	5.80	6.00	6.20	0.228	0.236	0.244
E1	3.80	3.90	4.00	0.150	0.154	0.157
e		1.27			0.050	
h	0.25		0.50	0.010		0.020
L	0.40		1.27	0.016		0.050
L1		1.04			0.040	
k	1°		8°	1°		8°
ccc			0.10			0.004



## TSSOP8 package information

Figure 16. TSSOP8 package mechanical drawing

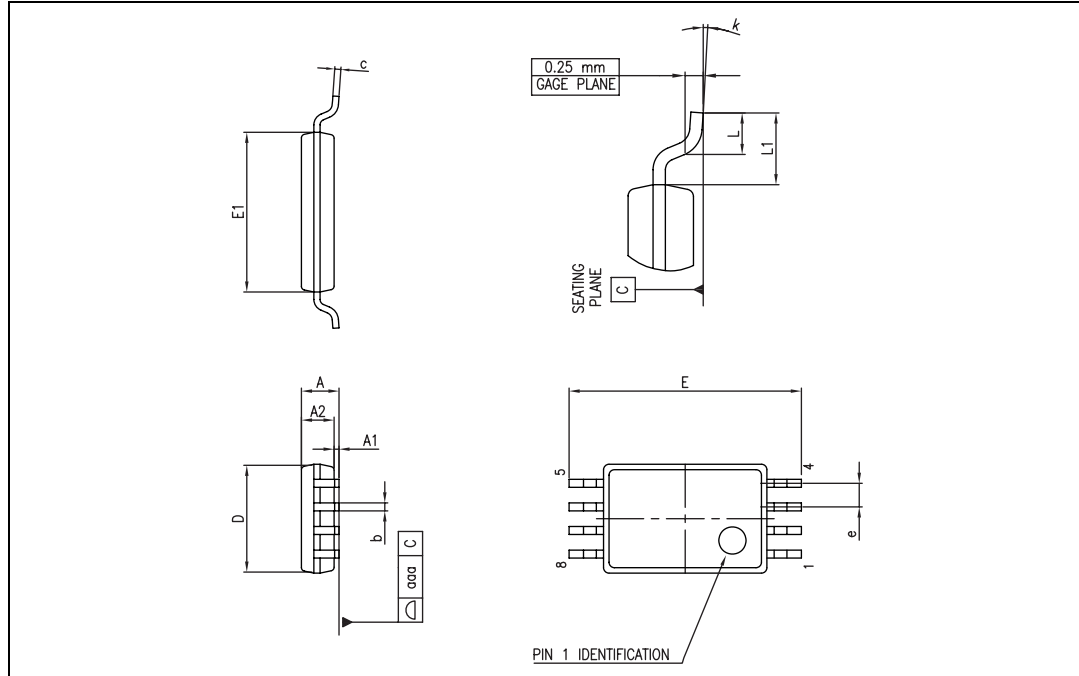


Table 6. TSSOP8 package mechanical data

Ref.	Dimensions					
	Millimeters			Inches		
	Min.	Typ.	Max.	Min.	Typ.	Max.
A			1.20			0.047
A1	0.05		0.15	0.002		0.006
A2	0.80	1.00	1.05	0.031	0.039	0.041
b	0.19		0.30	0.007		0.012
c	0.09		0.20	0.004		0.008
D	2.90	3.00	3.10	0.114	0.118	0.122
E	6.20	6.40	6.60	0.244	0.252	0.260
E1	4.30	4.40	4.50	0.169	0.173	0.177
e		0.65			0.0256	
k	0°		8°	0°		8°
L	0.45	0.60	0.75	0.018	0.024	0.030
L1		1			0.039	
aaa			0.10			0.004