

Features

- Uses advanced SGT technology
- Extremely low on-resistance $R_{DS(on)}$
- Excellent gate charge x $R_{DS(on)}$ product(FOM)

Application

- Motor control and drives
- Battery management
- DC/DC converter
- General purpose applications

Product Summary

	TO-220	TO-263
V_{DS}	80V	80V
$R_{DS(on)@VGS=10V}$	3.9m Ω	3.7m Ω
I_D	120A	120A



Package Marking and Ordering Information

Type	Package	Marking	Reel Size	Tape Width	Packing	Qty
LR049N08SA3	TO-220	LR049N08SA3	-	-	Tube	50
LR046N08SA2	TO-263	LR046N08SA2	330*28.5mm	24mm	Reel&Tape	800

Maximum Ratings

Parameter	Symbol	Value	Unit
Drain-source voltage	V_{DS}	80	V
Continuous drain current $T_C = 25^\circ\text{C}$ (Silicon limit) $T_C = 25^\circ\text{C}$ (Package limit) $T_C = 100^\circ\text{C}$ (Silicon limit)	I_D	150 120 100	A
Pulsed drain current $T_C = 25^\circ\text{C}$, t_p limited by T_{jmax}	$I_{D\ pulse}$	480	
Avalanche energy, single pulse (L=0.5mH,Rg=25 Ω)	E_{AS}	650	mJ
Gate-Source voltage	V_{GS}	± 20	V
Power dissipation $T_C = 25^\circ\text{C}$	P_D	189	W
Operating junction and storage temperature	T_j, T_{stg}	-55~150	$^\circ\text{C}$

Thermal Resistance

	Symbol	Value	Unit
Thermal resistance, junction – case. Max	R_{thJC}	0.64	°C/W
Thermal resistance, junction – ambient. Max	R_{thJA}	56	

Electrical Characteristic, at T_j = 25 °C, unless otherwise specified

Parameter	Symbol	Test Condition	Value			Unit
			min.	typ.	max.	

Static Characteristic

Drain-source breakdown voltage	$V_{(BR)DSS}$	$V_{GS}=0V, I_D=250\mu A$	80	-	-	V
Gate threshold voltage	$V_{GS(th)}$	$V_{DS}=V_{GS}, I_D=250\mu A$ $T_j=25^\circ C$	2	3	4	
Zero gate voltage drain current	I_{DSS}	$V_{DS}=80V, V_{GS}=0V$ $T_j=25^\circ C$	-	-	1	μA
		$V_{DS}=80V, T_j=125^\circ C$	-	-	10	
Gate-source leakage current	I_{GSS}	$V_{GS}=20V, V_{DS}=0V$	-	-	100	nA
Drain-source on-state resistance	$R_{DS(on)}$	$V_{GS}=10V, I_D=50A,$ $T_j=25^\circ C$ TO-220	-	3.9	4.9	mΩ
		TO-263	-	3.7	4.6	
Transconductance	g_{fs}	$V_{DS}=5V, I_D=40A$	-	88	-	S

Dynamic Characteristic

Input Capacitance	C_{iss}	$V_{GS}=0V, V_{DS}=40V,$ $f=1MHz$	-	4241	-	pF
Output Capacitance	C_{oss}		-	1250	-	
Reverse Transfer Capacitance	C_{rss}		-	33	-	
Gate Total Charge	Q_G	$V_{GS}=10V, V_{DS}=40V,$ $I_D=50A$	-	67	-	nC
Gate-Source charge	Q_{gs}		-	20	-	
Gate-Drain charge	Q_{gd}		-	18	-	
Turn-on delay time	$t_{d(on)}$	$T_j=25^\circ C, V_{GS}=10V,$ $V_{DS}=40V, R_L=3\Omega$	-	26	-	ns
Rise time	t_r		-	52	-	
Turn-off delay time	$t_{d(off)}$		-	54	-	
Fall time	t_f		-	28	-	
Gate resistance	R_G	$V_{GS}=0V, V_{DS}=0V,$ $f=1MHz$	-	3.3	-	Ω

Body Diode Characteristic

Body Diode Forward Voltage	V_{SD}	$V_{GS}=0V, I_{SD}=50A$	-	0.85	1.2	V
Body Diode Reverse Recovery Time	t_{rr}	$I_F=30A,$ $dI/dt=500A/\mu s$	-	67	-	ns
Body Diode Reverse Recovery Charge	Q_{rr}	$I_F=30A,$ $dI/dt=500A/\mu s$	-	79	-	nC

Typical Performance Characteristics

Figure 1. Typ. Output Characteristics (Tj=25°C)

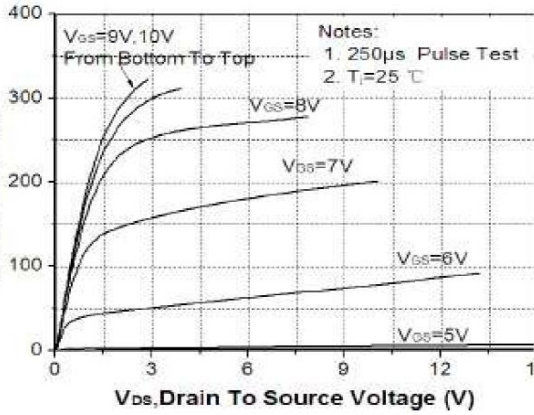

Figure 2. Transfer Characteristics (Junction Temperature)

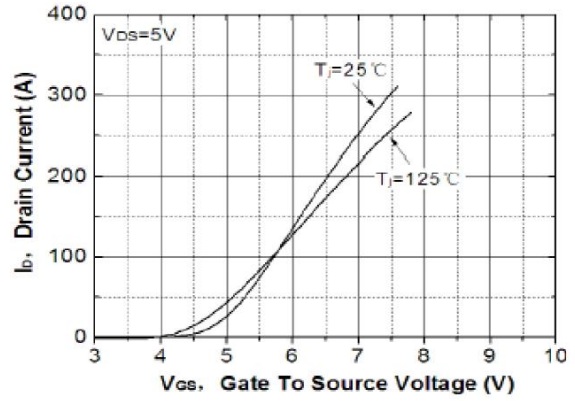

Figure 3. On-Resistance vs. Drain Current Junction and Gate Voltage Figure

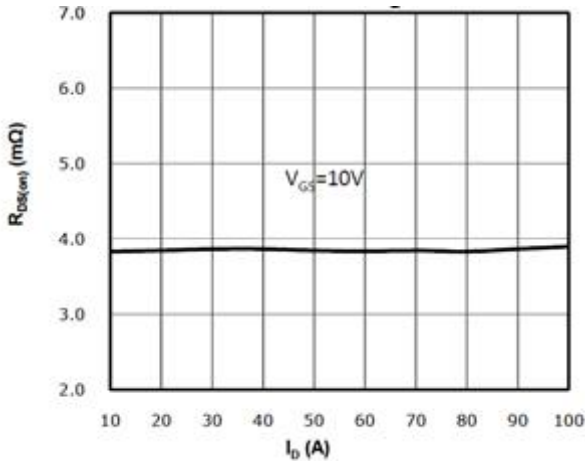

Figure 4. On-Resistance vs. Temperature

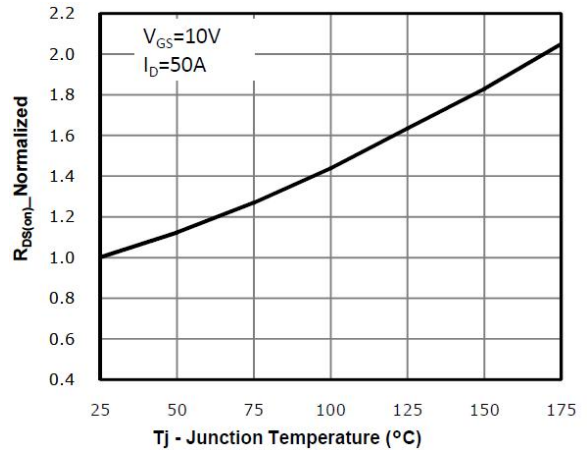

Figure 5. On-Resistance vs. Gate-Source Voltage (Junction Temperature)

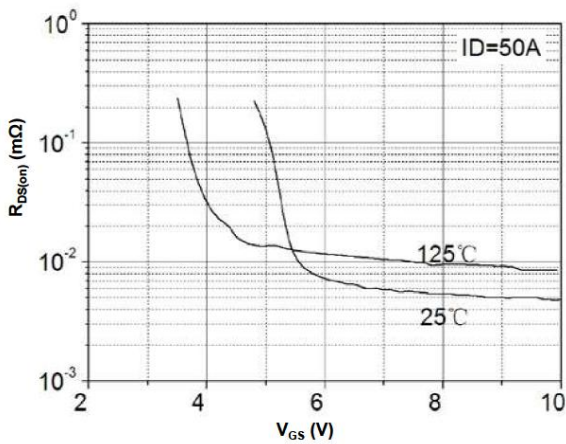

Figure 6. Body-Diode Characteristics (Junction Temperature)

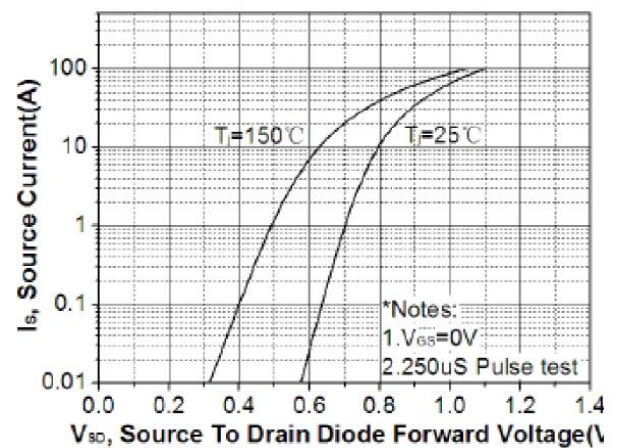

Figure 7. Gate-Charge Characteristics

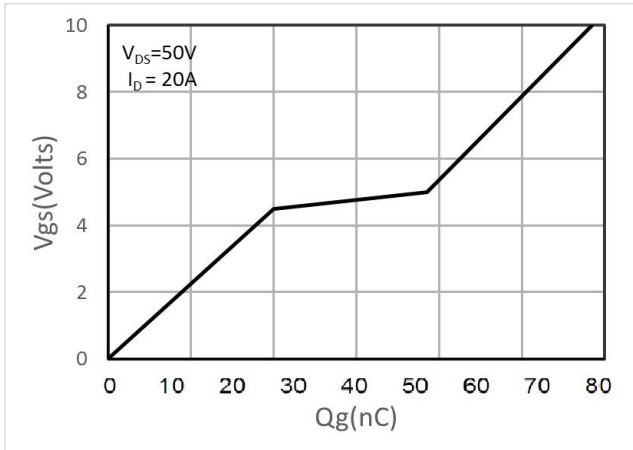

Figure 8. Drain Current Derating

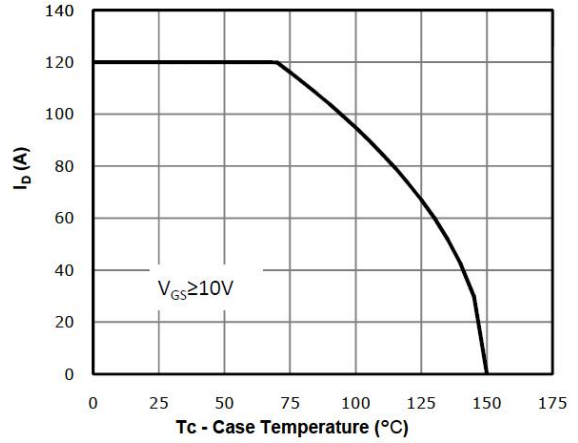

Figure 9. Capacitance Characteristics

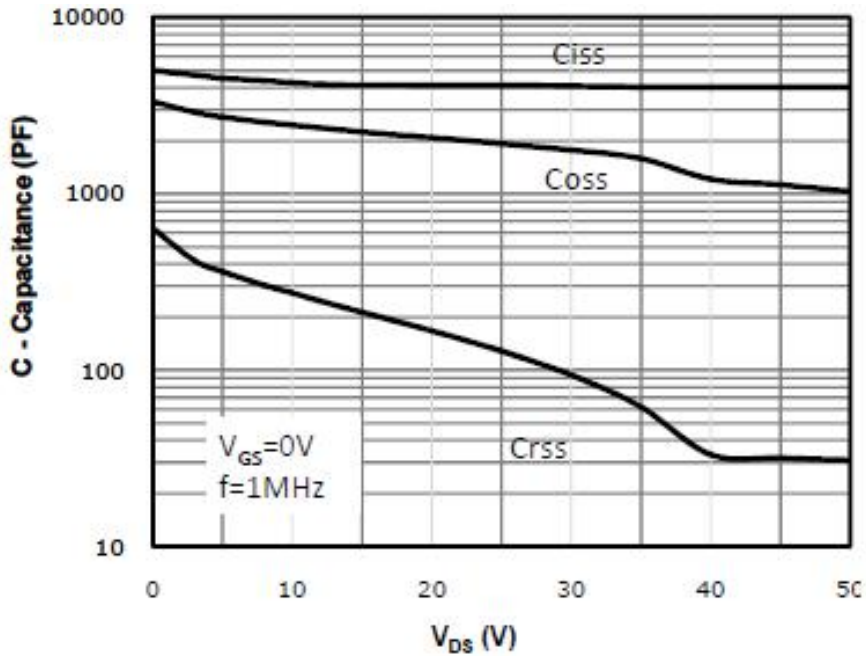
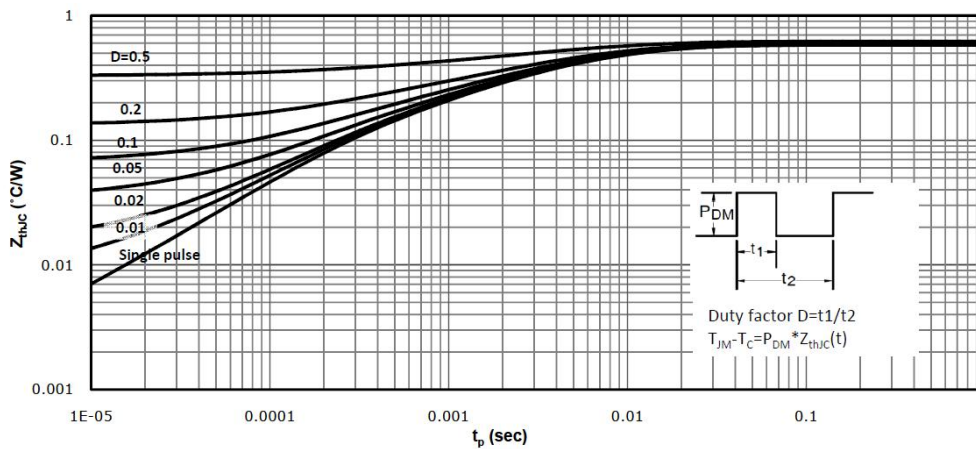
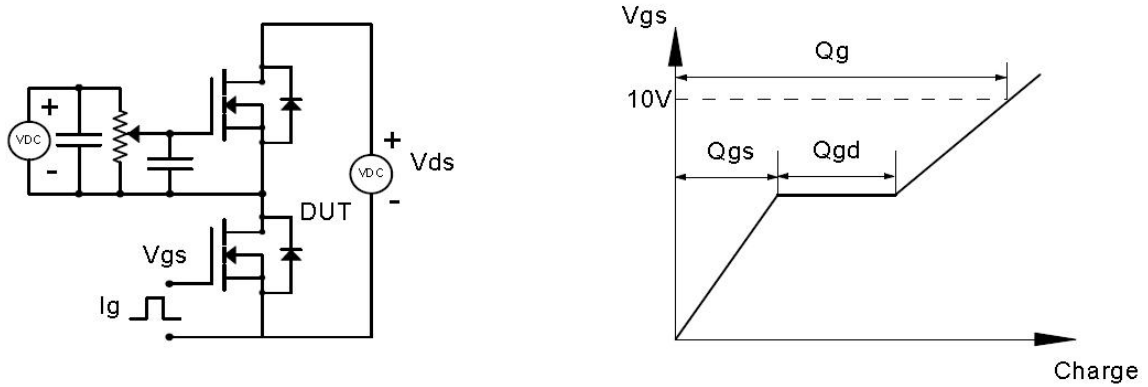

Figure 10. Normalized Maximum Transient Thermal Impedance (R_{thJC})



Test Circuit & Waveform

Gate Charge Test Circuit & Waveform



Resistive Switching Test Circuit & Waveforms

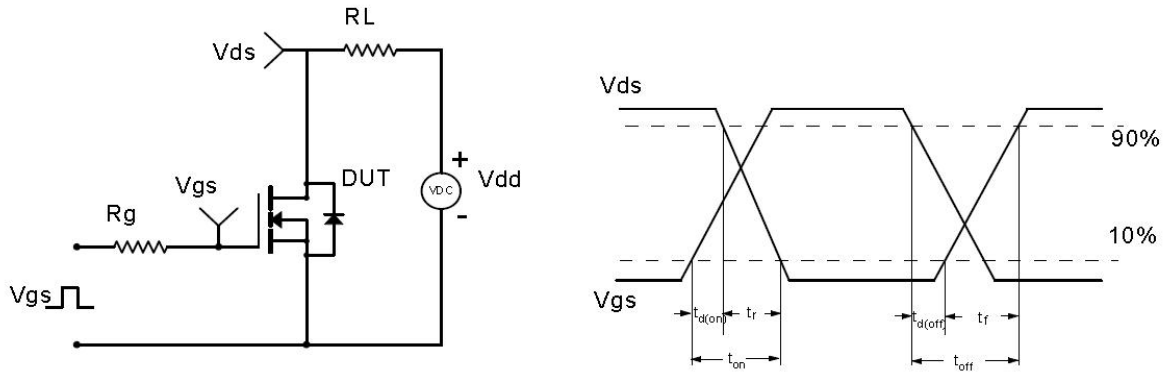

Unclamped Inductive Switching (UIS) Test Circuit & Waveforms

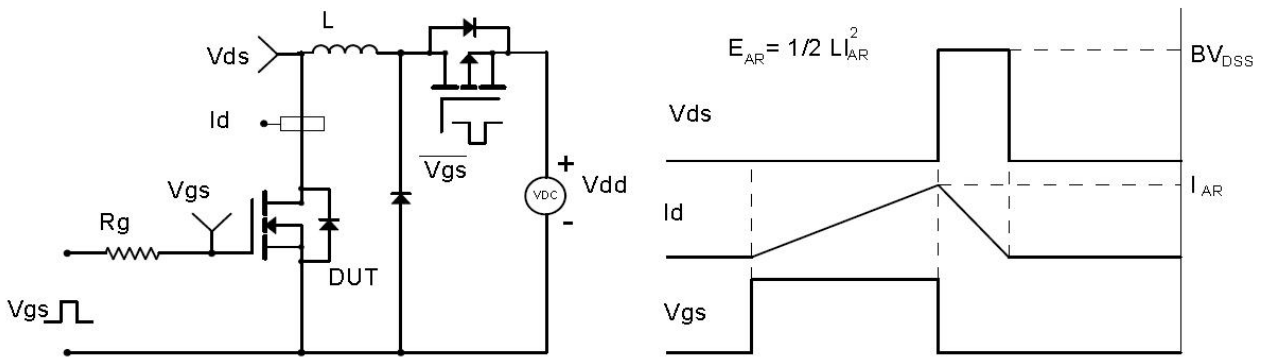

Diode Recovery Test Circuit & Waveforms

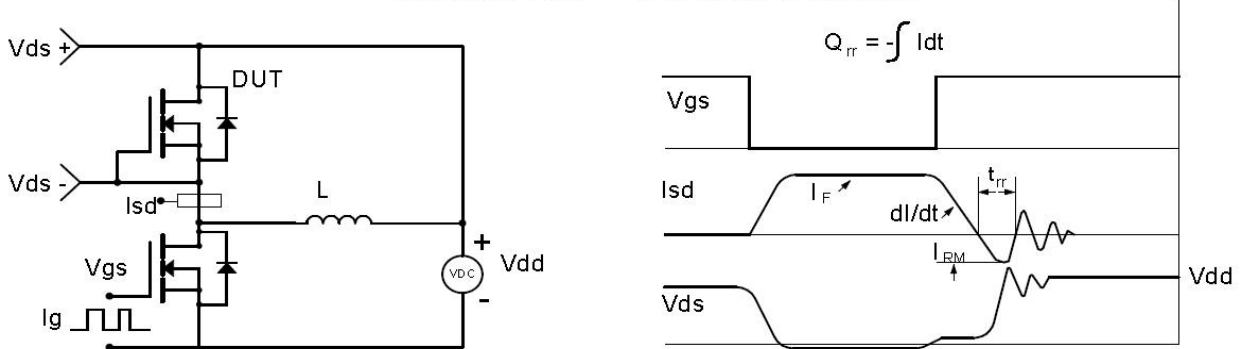

Package Outline: TO-220-3L

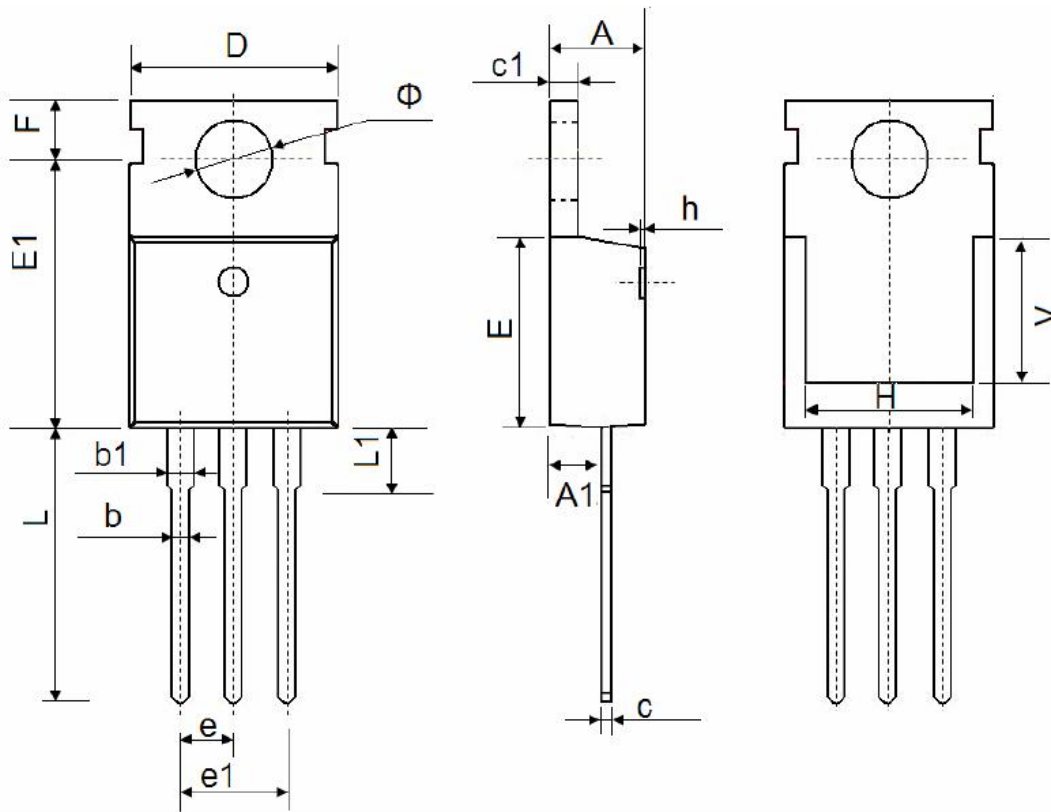

Symbol	Dimensions In Millimeters		Dimensions In Inches	
	Min.	Max.	Min.	Max.
A	4.400	4.600	0.173	0.181
A1	2.250	2.550	0.089	0.100
b	0.710	0.910	0.028	0.036
b1	1.170	1.370	0.046	0.054
c	0.330	0.650	0.013	0.026
c1	1.200	1.400	0.047	0.055
D	9.910	10.250	0.390	0.404
E	8.9500	9.750	0.352	0.384
E1	12.650	12.950	0.498	0.510
e	2.540 Typ.		0.100 Typ.	
e1	4.980	5.180	0.196	0.204
F	2.650	2.950	0.104	0.116
H	7.900	8.100	0.311	0.319
h	0.000	0.300	0.000	0.012
L	12.900	13.400	0.508	0.528
L1	2.850	3.250	0.112	0.128
V	7.500 Ref.		0.295 Ref.	
Φ	3.400	3.800	0.134	0.150

Package Outline: TO-263-2L

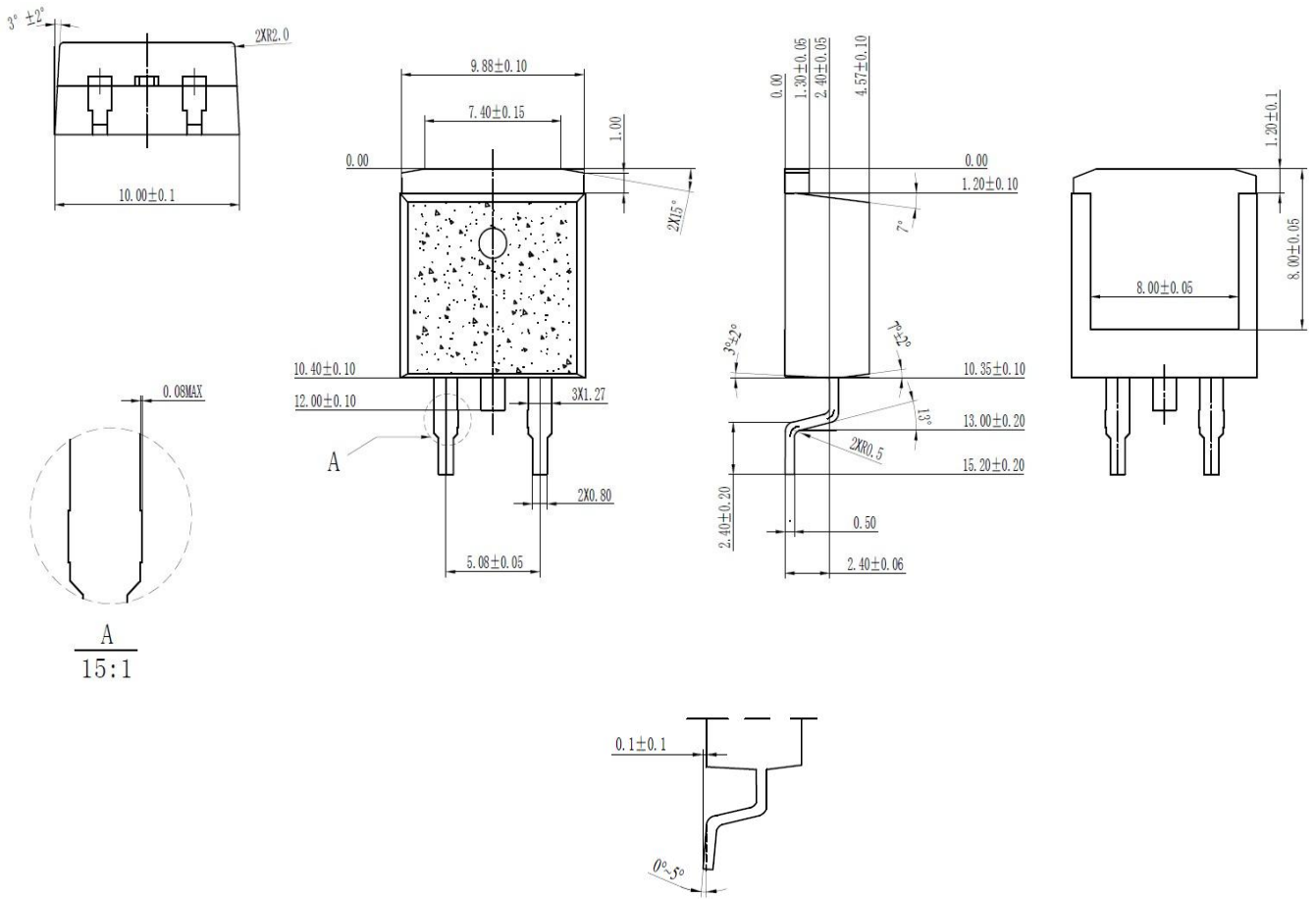

技术要求:

1. 塑封体中心与引线框架中心线偏差 ≤ 0.05 ,
上下塑封体中心偏差 ≤ 0.05 ;
2. 塑封体不准有缺损、气泡、气孔、裂纹等缺陷;
3. 塑封体表面除阴影部分为毛面, 其余为光面;
4. 未注脱模斜度 $\leq 5^\circ$;
5. 未注公差为 ± 0.05 , 未注圆角为R0.15 (max) 。

Revision History

Revision	Date	Major changes
0.0	2020/9/18	Preliminary Revision
1.0	2022/4/28	Official version