

Single Line Bi-directional Transient Voltage Suppressor

DESCRIPTION

The PTVSHC3D4V5B TVS diode is designed to replace multilayer varistors (MLVs) in portable applications such as cell phones, notebooks, and PDA's. It offers superior electrical characteristics such as low clamping voltage, low leakage current and high surge capability. It is designed to protect sensitive electronic components which are connected to power lines, from over-stress caused by ESD (Electrostatic Discharge), EFT (Electrical Fast Transients) and Lighting.

The PTVSHC3D4V5B is in a SOD-323 package and will protect one unidirectional line. It may be used to provide ESD protection up to $\pm 30\text{kV}$ (Contact and air discharge) according to IEC61000-4-2, and withstand peak pulse current up to 160A (8/20 μs) according to IEC61000-4-5.

ORDERING INFORMATION

- ✧ Device: PTVSHC3D4V5B
- ✧ Package: SOD-323
- ✧ Marking: D4
- ✧ Material: Halogen free and RoHS compliant
- ✧ Packing: Tape & Reel
- ✧ Quantity per reel: 3,000pcs

PIN CONFIGURATION



FEATURES

- ✧ Transient protection for high-speed data lines
IEC 61000-4-2 (ESD) $\pm 30\text{kV}$ (Contact)
 $\pm 30\text{kV}$ (Air)
- ✧ Peak power dissipation: 3200W (8/20 μs)
- ✧ Working voltages : 4.5V
- ✧ Low leakage current
- ✧ Low clamping voltage
- ✧ Solid-state silicon-avalanche technology

MACHANICAL DATA

- ✧ SOD-323 package
- ✧ Flammability Rating: UL 94V-0
- ✧ High temperature soldering guaranteed:
260°C/10s
- ✧ Packaging: Tape and Reel
- ✧ Reel size: 7 inch

APPLICATIONS

- ✧ Power lines
- ✧ Personal digital assistants (PDA's)
- ✧ Microprocessors based equipment
- ✧ Notebooks, Desktops, and Servers
- ✧ Cell phone Handsets and Accessories
- ✧ Portable Electronics
- ✧ Peripherals

PACKAGE OUTLINE



ABSOLUTE MAXIMUM RATING			
Symbol	Parameter	Value	Units
V _{ESD}	ESD per IEC 61000-4-2 (Contact)	±30	kV
	ESD per IEC 61000-4-2 (Air)	±30	
P _{PP}	Peak Pulse Power (8/20μs)	3200	W
T _{OPT}	Operating Temperature	-55~125	°C
T _{STG}	Storage Temperature	-55~150	°C
T _L	Lead Soldering Temperature	260(10sec)	°C

ELECTRICAL CHARACTERISTICS (T _{amb} =25°C)						
Symbol	Parameter	Test Condition	Min	Typ	Max	Units
V _{RWM}	Reverse Working Voltage				4.5	V
V _{BR}	Reverse Breakdown Voltage	I _T = 1mA	4.6	5.2	6.4	V
I _R	Reverse Leakage Current	V _{RWM} = 4.5V			1	uA
I _{PP}	Peak Pulse Current	t _p = 8/20μs			160	A
V _C	Clamping Voltage	I _{PP} = 50A, t _p = 8/20μs		8.5	11	V
		I _{PP} = 100A, t _p = 8/20μs		12	14	V
		I _{PP} = 160A, t _p = 8/20μs		17	20	V
C _J	Junction Capacitance	V _R = 0V, f = 1MHz		300	500	pF

ELECTRICAL CHARACTERISTICS CURVE

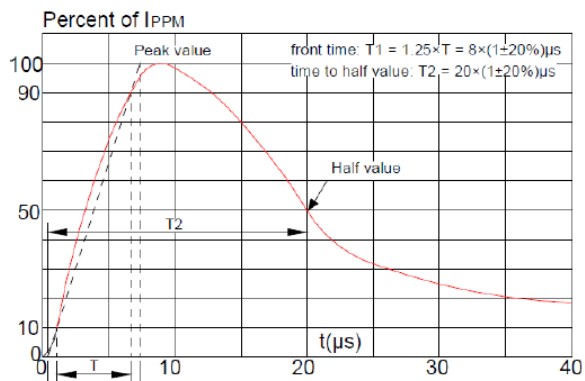

Pulse Waveform (8/20us)

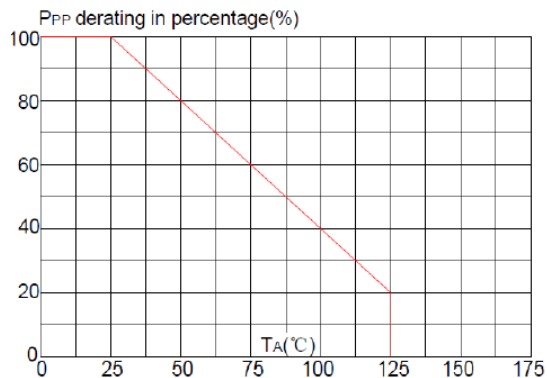

Pulse Derating Curve

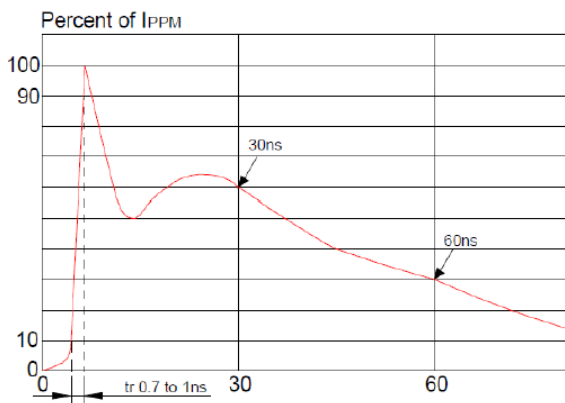

ESD Clamping(8kV Contact Discharge)

SOD-323 PACKAGE OUTLINE DIMENSIONS

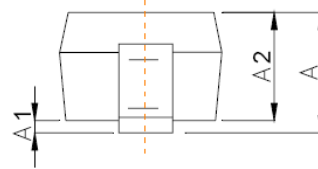
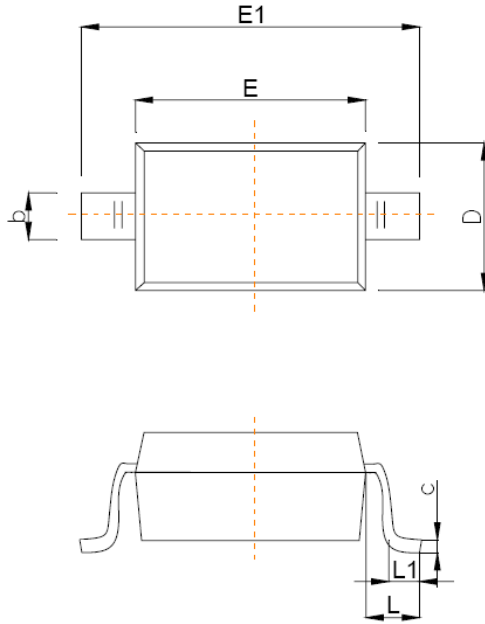

Symbol	Dimensions In Millimeters	
	Min	Max
A		1.00
A1	0.000	0.100
A2	0.800	0.900
b	0.250	0.350
c	0.080	0.150
D	1.200	1.400
E	1.600	1.800
E1	2.500	2.700
e	1.800	2.040
L	0.475 REF	
L1	0.250	0.400
θ	0°	8°

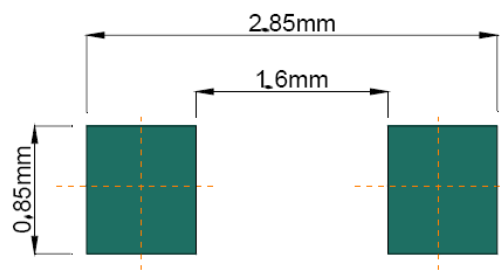

Recommended Pad outline