

3.3V, 4-Bit, 2-Port Nanoswitchw/Individual Enables

Features

- Near zero propagation delay
- 5 Ohm switches connect inputs to outputs
- Fast Switching Speed - 4ns max.
- Ultra Low Quiescent Power (0.1µA Typical)
 - Ideally suited for notebook applications
- Totally Lead-Free & Fully RoHS Compliant (Notes 1 & 2)
- Halogen and Antimony Free. “Green” Device (Note 3)
- For automotive applications requiring specific change control (i.e. parts qualified to AEC-Q100/101/104/200, PPAP capable, and manufactured in IATF 16949 certified facilities), please [contact us](http://www.diodes.com/contact-us) or your local Diodes representative.
<https://www.diodes.com/quality/product-definitions/>
- Packaging (Pb-free & Green available):
 - 14-pin, SOIC (W), PI3B3125 only
 - 14-pin, TSSOP (L)
 - 16-pin, QSOP (Q)

Description

Diodes' PI3B series of logic circuits are produced using the Company's advanced sub micron CMOS technology, achieving industry leading speed grades.

The PI3B3125 and PI3B3126 are 3.3 Volt, 4-bit bus switches designed with four individual 5Ω bus switches with fast individual enables in an industry standard 74XX125/126 pinout. When enabled via the associated Bus Enable (\overline{BE}) pin, the “A” pin is directly connected to the “B” pin for that particular gate. The bus switch introduces no additional propagation delay or additional ground bounce noise.

The PI3B3125 device has active LOW enables, and the PI3B3126 has active HIGH enables.

Logic Block Diagram

PI3B3125

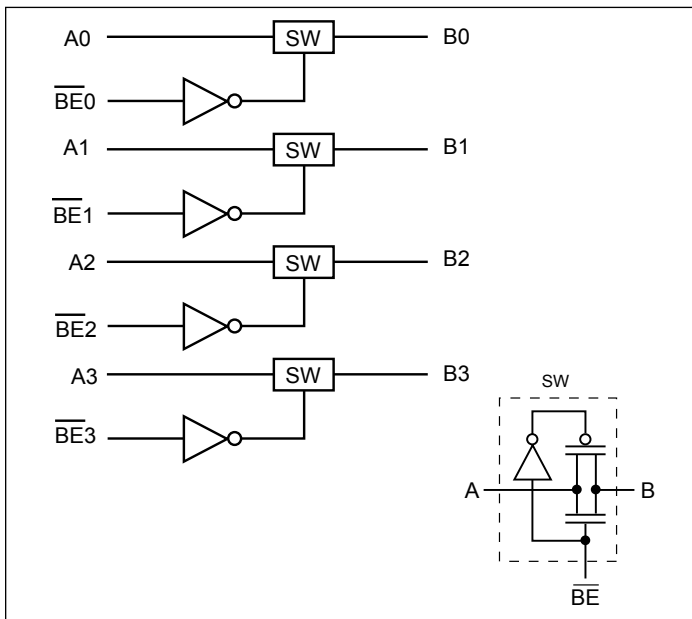

PI3B3126

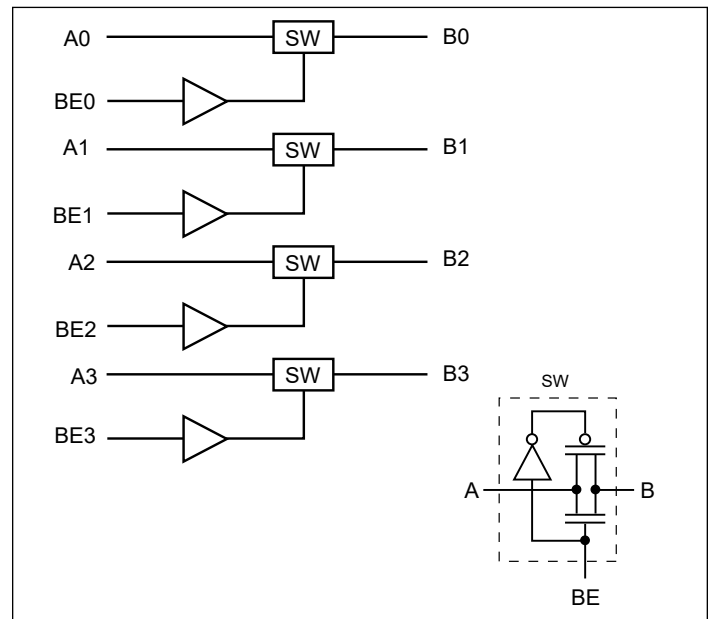

Notes:

1. No purposely added lead. Fully EU Directive 2002/95/EC (RoHS), 2011/65/EU (RoHS 2) & 2015/863/EU (RoHS 3) compliant.
2. See <https://www.diodes.com/quality/lead-free/> for more information about Diodes Incorporated's definitions of Halogen- and Antimony-free, "Green" and Lead-free.
3. Halogen- and Antimony-free "Green" products are defined as those which contain <900ppm bromine, <900ppm chlorine (<1500ppm total Br + Cl) and <1000ppm antimony compounds.

Pin Configuration

PI3B3125

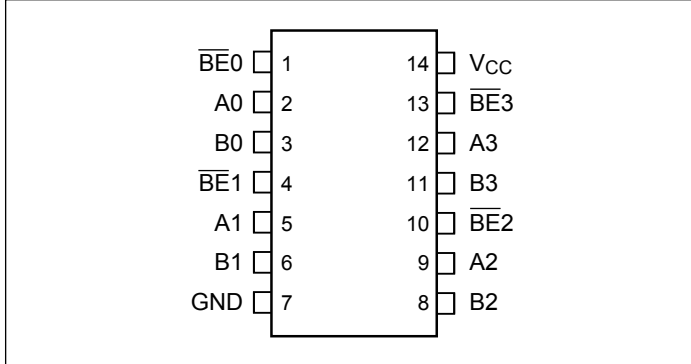

14-Pin, SOIC and TSSOP

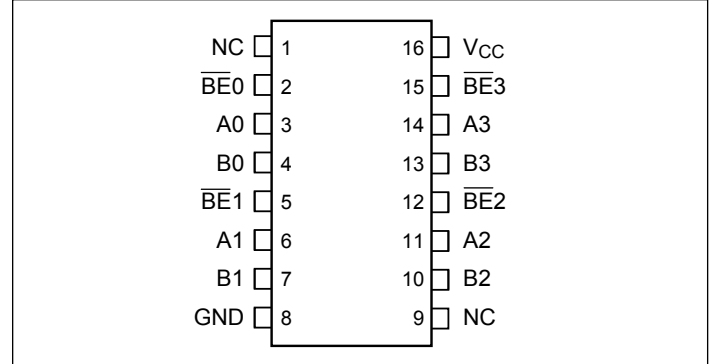

16-Pin, QSOP

PI3B3126

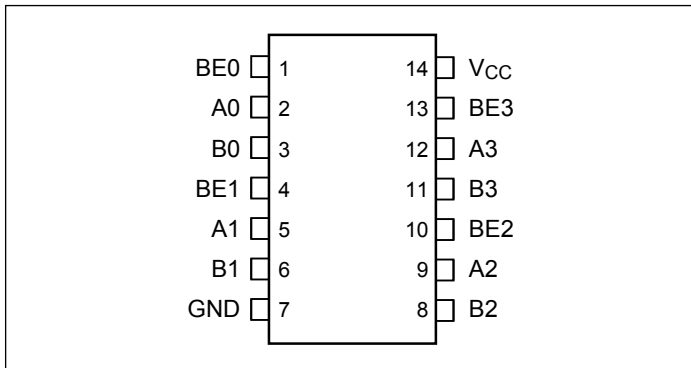

14-Pin, TSSOP

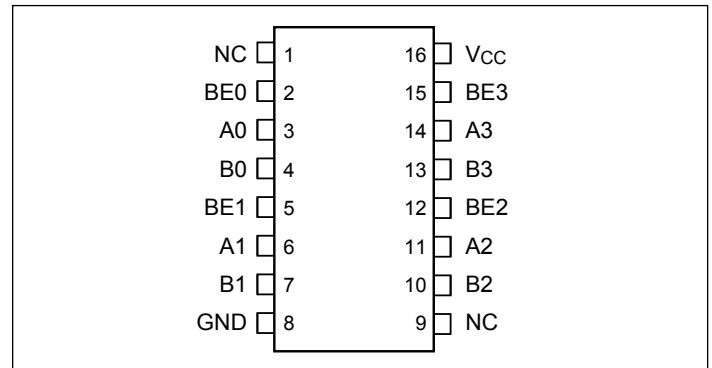

16-Pin, QSOP

Pin Description

Pin Name	Description
$\overline{\text{BE}}_n$	Switch Enable (PI3B3125)
BE_n	Switch Enable (PI3B3126)
A3-A0	Bus A
B3-B0	Bus B
V_{CC}	Power
GND	Ground

Truth Table⁽¹⁾

PI3B3125 $\overline{\text{BE}}_n$	PI3B3126 BE_n	A_n	B_n	V_{CC}	Function
X ⁽²⁾	X	Hi-Z	Hi-Z	GND	Disconnect
H	L	Hi-Z	Hi-Z	V_{CC}	Disconnect
L	H	B_n	A_n	V_{CC}	Connect

Notes:

- H = High Voltage Level, L = Low Voltage Level
HI-Z = High Impedance, X = Don't Care
- A pull-up resistor should be provided for power-up protection.

Maximum Ratings

(Above which the useful life may be impaired. For user guidelines, not tested.)

Storage Temperature.....	-65°C to +150°C
Supply Voltage to Ground Potential.....	-0.5V to +4.6V
DC Input Voltage.....	-0.5V to +4.6V
DC Output Current.....	120mA
Power Dissipation.....	0.5W
Junction Temperature (T _j).....	Max. 125°C

Note:

Stresses greater than those listed under MAXIMUM RATINGS may cause permanent damage to the device. This is a stress rating only and functional operation of the device at these or any other conditions above those indicated in the operational sections of this specification is not implied. Exposure to absolute maximum rating conditions for extended periods may affect reliability.

DC Electrical Characteristics

(Over the Operating Range, T_A = -40°C to +85°C, V_{CC} = 3.3V ±10%)

Parameter	Description	Test Conditions ⁽¹⁾	Min.	Typ. ⁽²⁾	Max.	Units
V _{IH}	Input HIGH Voltage	Guaranteed Logic HIGH Level	2.0			V
V _{IL}	Input LOW Voltage	Guaranteed Logic LOW Level	-0.5		0.8	V
I _{IH}	Input HIGH Current	V _{CC} = Max., V _{IN} = V _{CC}			±1	MA
I _{IL}	Input LOW Current	V _{CC} = Max., V _{IN} = GND			±1	MA
I _{OFF}	Off Current	V _{CC} = 0, V _{OUT} = 3 to 3.6V			10	MA
V _{IK}	Clamp Diode Voltage	V _{CC} = Min., I _{IN} = -18mA			-1.2	V
R _{ON}	Switch On Resistance ⁽³⁾	V _{CC} = Min., V _{IN} = 0.0V, I _{ON} = 48mA or 60mA		5	8	Ω
		V _{CC} = Min., V _{IN} = 2.4V, I _{ON} = 15mA		10	17	

Notes:

- For Max. or Min. conditions, use appropriate value specified under Electrical Characteristics for the applicable device type.
- Typical values are at V_{CC} = 3.3V, T_A = 25°C ambient and maximum loading.
- Measured by the voltage drop between A and B pin at indicated current through the switch. ON resistance is determined by the lower of the voltages on the two (A, B) pins.

Capacitance

(T_A = 25°C, f = 1 MHz)

Parameter ⁽¹⁾	Description	Test Conditions	Min.	Typ.	Max.	Units
C _{IN}	Input Capacitance	V _{IN} = 0V		3.5		pF
C _{OFF}	A/B Capacitance, Switch Off	V _{IN} = 0V		8		pF

Note:

- This parameter is determined by device characterization but is not production tested.

Power Supply Characteristics

Parameter	Description	Test Conditions ⁽¹⁾		Min.	Typ. ⁽²⁾	Max.	Units
I _{CC}	Quiescent Power Supply Current	V _{CC} = Max.	V _{IN} = GND or V _{CC}		0.1	3	μA
ΔI _{CC}	Supply Current per Input HIGH	V _{CC} = Max.	V _{IN} = 3.0V ⁽³⁾			750	μA

Notes:

- For Max. or Min. conditions, use appropriate value specified under Electrical Characteristics for the applicable device.
- Typical values are at V_{CC} = 3.3V, +25°C ambient.
- Per driven input (control inputs only); A and B pins do not contribute to I_{CC}.

Switching Characteristics over Operating Range

Parameter	Description	Conditions ⁽¹⁾	PI3B3125		Units
			Com.		
			Min.	Max.	
t _{PLH} t _{PHL}	Propagation Delay ^(2,3) Ax to Bx, Bx to Ax	C _L = 50pF R _L = 500Ω		0.25	ns
t _{PZH} t _{PZL}	Bus Enable Time	C _L = 50pF R _L = 500Ω	1.0	3.0	ns
t _{PHZ} t _{PLZ}	Bus Disable Time	R _L = 500Ω	1.0	4.0	ns

Parameter	Description	Conditions ⁽¹⁾	PI3B3126		Units
			Com.		
			Min.	Max.	
t _{PLH} t _{PHL}	Propagation Delay ^(2,3) Ax to Bx, Bx to Ax	C _L = 50pF R _L = 500Ω		0.25	ns
t _{PZH} t _{PZL}	Bus Enable Time	C _L = 50pF R _L = 500Ω	1.0	2.5	ns
t _{PHZ} t _{PLZ}	Bus Disable Time	R _L = 500Ω	1.0	4.0	ns

Notes:

- See test circuit and waveforms.
- This parameter is guaranteed but not tested on Propagation Delays.
- The bus switch contributes no propagational delay other than the RC delay of the ON resistance of the switch and the load capacitance. The time constant for the switch alone is of the order of 0.25ns for 50pF load. Since this time constant is much smaller than the rise/fall times of typical driving signals, it adds very little propagational delay to the system. Propagational delay of the bus switch when used in a system is determined by the driving circuit on the driving side of the switch and its interaction with the load on the driven side.

Applications Information

Logic Inputs

The logic control inputs can be driven up to +3.6V regardless of the supply voltage. For example, given a + 3.3V supply, IN may be driven low to 0V and high to 3.6V. Driving IN Rail-to-Rail® minimizes power consumption.



Power-Supply Sequencing and Hot-Plug Information

Proper power-supply sequencing is recommended for all CMOS devices. Always apply V_{CC} and GND before applying signals to input/output or control pins.

Rail-to-Rail is a registered trademark of Nippon Motorola, Ltd.

Part Marking

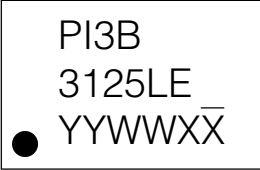
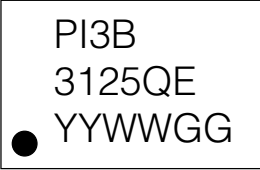
PI3B3125

L Package	Q Package	W Package
		
YY: Year WW: Workweek 1st X: Assembly Site Code 2nd X: Fab Site Code	YY: Year WW: Workweek 1st G: Assembly Site Code 2nd G: Wafer Fab Site Code	YY: Year WW: Workweek 1st X: Assembly Site Code 2nd X: Wafer Fab Site Code

PI3B3126

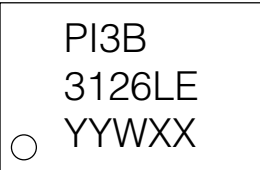
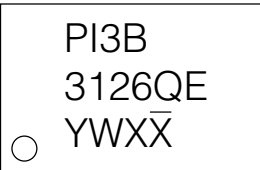
L Package	Q Package
	
1st Y: Die Rev 2nd Y: Year W: Workweek 1st X: Assembly Code 2nd X: Fab Code	Y: Year W: Workweek 1st X: Assembly Site Code 2nd X: Fab Site Code

Packaging Mechanical

14-TSSOP (L)

SYMBOLS	MIN.	NOM.	MAX.
A	–	–	1.20
A1	0.05	–	0.15
A2	0.80	1.00	1.05
b	0.19	–	0.30
c	0.09	–	0.20
D	4.90	5.00	5.10
E1	4.30	4.40	4.50
E	6.20	6.40	6.60
e	0.65 BSC		
L1	1.00 REF		
L	0.45	0.60	0.75
S	0.20	–	–
θ	0°	–	8°

NOTES:
 1. ALL DIMENSIONS IN MILLIMETERS. ANGLES IN DEGREES.
 2. JEDEC MO-153F
 3. DIMENSIONS DOES NOT INCLUDE MOLD FLASH, PROTRUSIONS OR GATE BURRS.

		DATE: 03/24/16
DESCRIPTION: 14-Pin, 173mil Wide TSSOP		
PACKAGE CODE: L (L14)		
DOCUMENT CONTROL #: PD-1309	REVISION: E	

16-0060

PI3B3125/PI3B3126

14-SOIC (W)

SYMBOLS	MIN.	NOM.	MAX.
A	—	—	1.75
A1	0.10	—	0.25
A2	1.25	—	—
b	0.31	—	0.51
c	0.10	—	0.25
D	8.55	8.65	8.75
E	5.80	6.00	6.20
E1	3.70	3.90	4.10
e	1.27 BSC		
L	0.40	—	1.27
L1	1.04 REF		
h	0.25	—	0.50
θ°	0	—	8

NOTES:
 1. ALL DIMENSIONS ARE IN mm. ANGLES IN DEGREES.
 2. JEDEC MS-012
 3. DIMENSIONS DOES NOT INCLUDE MOLD FLASH, PROTRUSIONS OR GATE BURRS.

PERICOM
Enabling Serial Connectivity

DATE: 03/24/16

DESCRIPTION: 14-Pin, 150mil Wide SOIC

PACKAGE CODE: W (W14)

DOCUMENT CONTROL #: PD-1002

REVISION: E

16-0055

16-QSOP (Q)

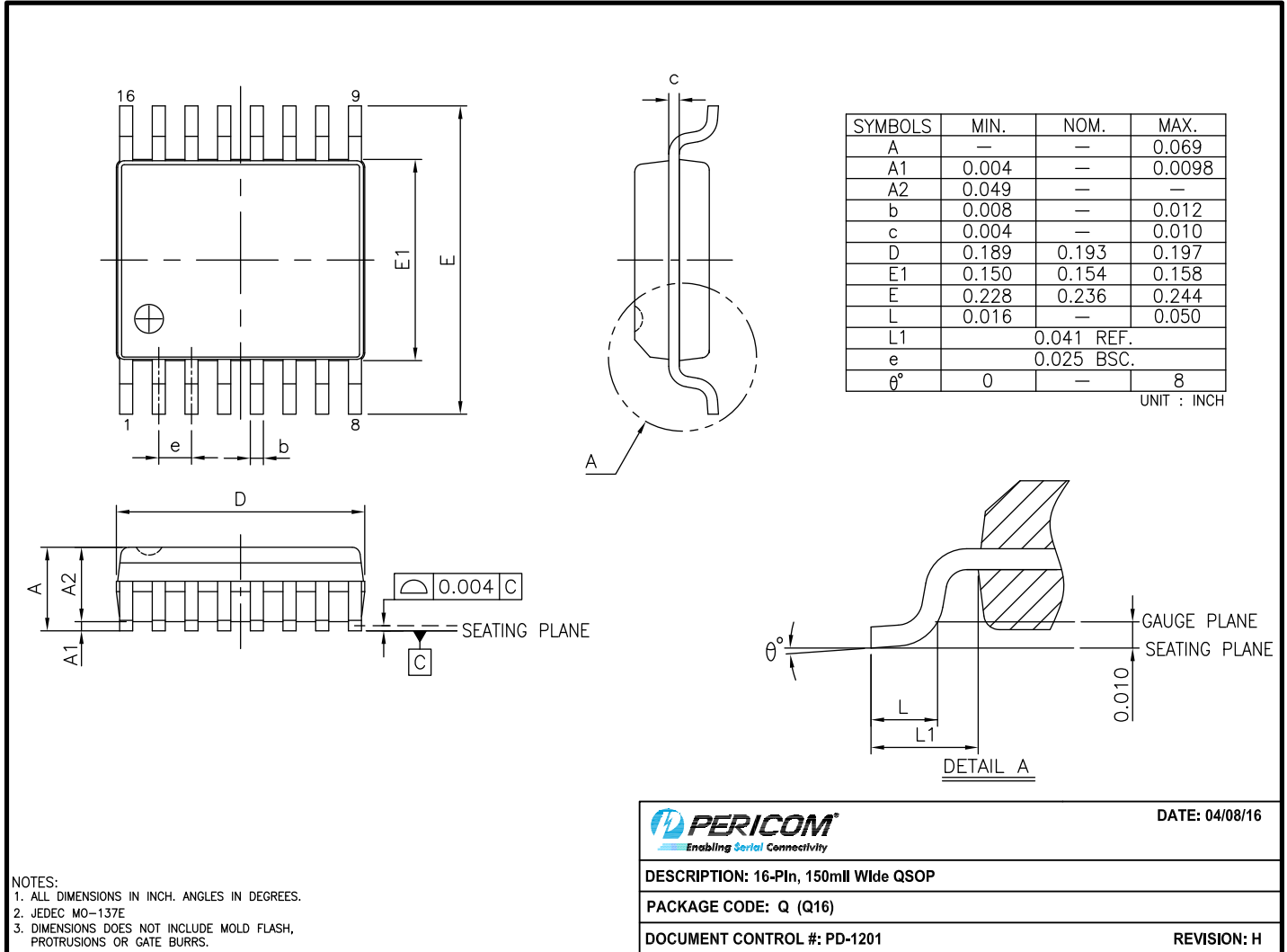

16-0056

For latest package info.

please check: <http://www.diodes.com/design/support/packaging/pericom-packaging/packaging-mechanicals-and-thermal-characteristics/>

Ordering Information

Ordering Code	Package Code	Package Description
PI3B3125LEX	L	14-Pin, 173mil Wide (TSSOP)
PI3B3125WEX	W	14-Pin, 150mil Wide (SOIC)
PI3B3125QEX	Q	16-Pin, 150mil Wide(QSOP)
PI3B3126LEX	L	14-Pin, 173mil Wide (TSSOP)
PI3B3126QEX	Q	16-Pin, 150mil Wide(QSOP)

Notes:

- No purposely added lead. Fully EU Directive 2002/95/EC (RoHS), 2011/65/EU (RoHS 2) & 2015/863/EU (RoHS 3) compliant.
- See <https://www.diodes.com/quality/lead-free/> for more information about Diodes Incorporated's definitions of Halogen- and Antimony-free, "Green" and Lead-free.
- Halogen- and Antimony-free "Green" products are defined as those which contain <900ppm bromine, <900ppm chlorine (<1500ppm total Br + Cl) and <1000ppm antimony compounds.
- E = Pb-free and Green
- X suffix = Tape/Reel

IMPORTANT NOTICE

1. DIODES INCORPORATED AND ITS SUBSIDIARIES ("DIODES") MAKE NO WARRANTY OF ANY KIND, EXPRESS OR IMPLIED, WITH REGARDS TO ANY INFORMATION CONTAINED IN THIS DOCUMENT, INCLUDING, BUT NOT LIMITED TO, THE IMPLIED WARRANTIES OF MERCHANTABILITY, FITNESS FOR A PARTICULAR PURPOSE OR NON-INFRINGEMENT OF THIRD PARTY INTELLECTUAL PROPERTY RIGHTS (AND THEIR EQUIVALENTS UNDER THE LAWS OF ANY JURISDICTION).

2. The Information contained herein is for informational purpose only and is provided only to illustrate the operation of Diodes products described herein and application examples. Diodes does not assume any liability arising out of the application or use of this document or any product described herein. This document is intended for skilled and technically trained engineering customers and users who design with Diodes products. Diodes products may be used to facilitate safety-related applications; however, in all instances customers and users are responsible for (a) selecting the appropriate Diodes products for their applications, (b) evaluating the suitability of the Diodes products for their intended applications, (c) ensuring their applications, which incorporate Diodes products, comply the applicable legal and regulatory requirements as well as safety and functional-safety related standards, and (d) ensuring they design with appropriate safeguards (including testing, validation, quality control techniques, redundancy, malfunction prevention, and appropriate treatment for aging degradation) to minimize the risks associated with their applications.

3. Diodes assumes no liability for any application-related information, support, assistance or feedback that may be provided by Diodes from time to time. Any customer or user of this document or products described herein will assume all risks and liabilities associated with such use, and will hold Diodes and all companies whose products are represented herein or on Diodes' websites, harmless against all damages and liabilities.

4. Products described herein may be covered by one or more United States, international or foreign patents and pending patent applications. Product names and markings noted herein may also be covered by one or more United States, international or foreign trademarks and trademark applications. Diodes does not convey any license under any of its intellectual property rights or the rights of any third parties (including third parties whose products and services may be described in this document or on Diodes' website) under this document.

5. Diodes products are provided subject to Diodes' Standard Terms and Conditions of Sale (<https://www.diodes.com/about/company/terms-and-conditions/terms-and-conditions-of-sales/>) or other applicable terms. This document does not alter or expand the applicable warranties provided by Diodes. Diodes does not warrant or accept any liability whatsoever in respect of any products purchased through unauthorized sales channel.

6. Diodes products and technology may not be used for or incorporated into any products or systems whose manufacture, use or sale is prohibited under any applicable laws and regulations. Should customers or users use Diodes products in contravention of any applicable laws or regulations, or for any unintended or unauthorized application, customers and users will (a) be solely responsible for any damages, losses or penalties arising in connection therewith or as a result thereof, and (b) indemnify and hold Diodes and its representatives and agents harmless against any and all claims, damages, expenses, and attorney fees arising out of, directly or indirectly, any claim relating to any noncompliance with the applicable laws and regulations, as well as any unintended or unauthorized application.

7. While efforts have been made to ensure the information contained in this document is accurate, complete and current, it may contain technical inaccuracies, omissions and typographical errors. Diodes does not warrant that information contained in this document is error-free and Diodes is under no obligation to update or otherwise correct this information. Notwithstanding the foregoing, Diodes reserves the right to make modifications, enhancements, improvements, corrections or other changes without further notice to this document and any product described herein. This document is written in English but may be translated into multiple languages for reference. Only the English version of this document is the final and determinative format released by Diodes.

8. Any unauthorized copying, modification, distribution, transmission, display or other use of this document (or any portion hereof) is prohibited. Diodes assumes no responsibility for any losses incurred by the customers or users or any third parties arising from any such unauthorized use.

Copyright © 2022 Diodes Incorporated

www.diodes.com