

■ Features

- Molding Inductor.
- Low Profile,Low Temp.
- Large Current(Over 15A).
- Customize For Different Need.
- Operating temperature:-40°C ~ +125°C.

■ Applications

- General Electronic.
- Video Device,TV,TFT.
- Power Module for PC.
- NB/Lap Top Computer.
- Server,VGA Card/Module.

■ Product Identification

$\frac{\text{YSPI}}{(1)} \quad \frac{\square\square\square\square}{(2)} - \frac{\square\square\square}{(3)} \quad \frac{\square}{(4)}$

(1) : Type

(2) : Dimensions

(3) : Inductance value

(4) : Inductance Tolerance : N=±30%,M=±20% , K=±10%

■ Shapes and Dimensions (Unit: mm)

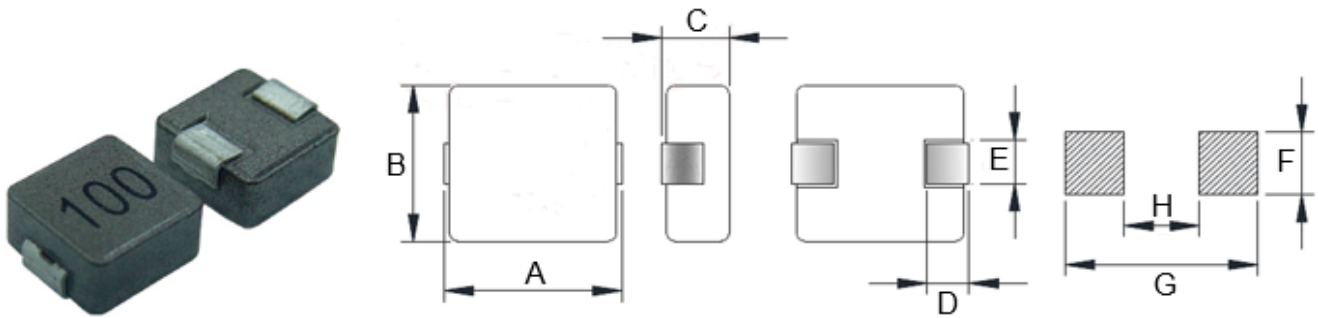

TYPE	A	B	C Max.	D	E Ref.	F Ref.	G Ref.	H Ref.
YSPI0724	7.3±0.5	6.6±0.5	2.4	1.6±0.5	3.0±0.3	3.5	8.4	3.5

■ YSPI0724 Series

Part Number	Inductance (uH) @100KHz	DCR Max. (mΩ)	Heat Rating Current (A)	Saturation Current (A)
YSPI0724-R22M	0.22 ± 20%	3.5	16	30
YSPI0724-R47M	0.47 ± 20%	6.5	15	22
YSPI0724-R68M	0.68 ± 20%	9.5	11	18
YSPI0724-1R0M	1.0 ± 20%	13.5	9	16
YSPI0724-1R5M	1.5 ± 20%	20	8	15
YSPI0724-2R2M	2.2 ± 20%	28	6	11
YSPI0724-3R3M	3.3 ± 20%	39	5.5	10.0
YSPI0724-4R7M	4.7 ± 20%	50	5.0	7.0
YSPI0724-6R8M	6.8 ± 20%	70	4.0	6.0
YSPI0724-8R2M	8.2 ± 20%	95	3.5	5.0
YSPI0724-100M	10 ± 20%	101	3.1	4.0
YSPI0724-150M	15 ± 20%	160	2.5	3.3

- ※ The saturation current value is the DC current value having inductance decrease down to 30%. (at 20°C)
- ※ The temperature rise current value is the DC current value having temperature increase up to 40°C. (at 20°C)
- ※ The rated current is the DC current value that satisfies both of current value saturation current value and temperature rise current value.

■ Taping Dimensions(Unit:mm)

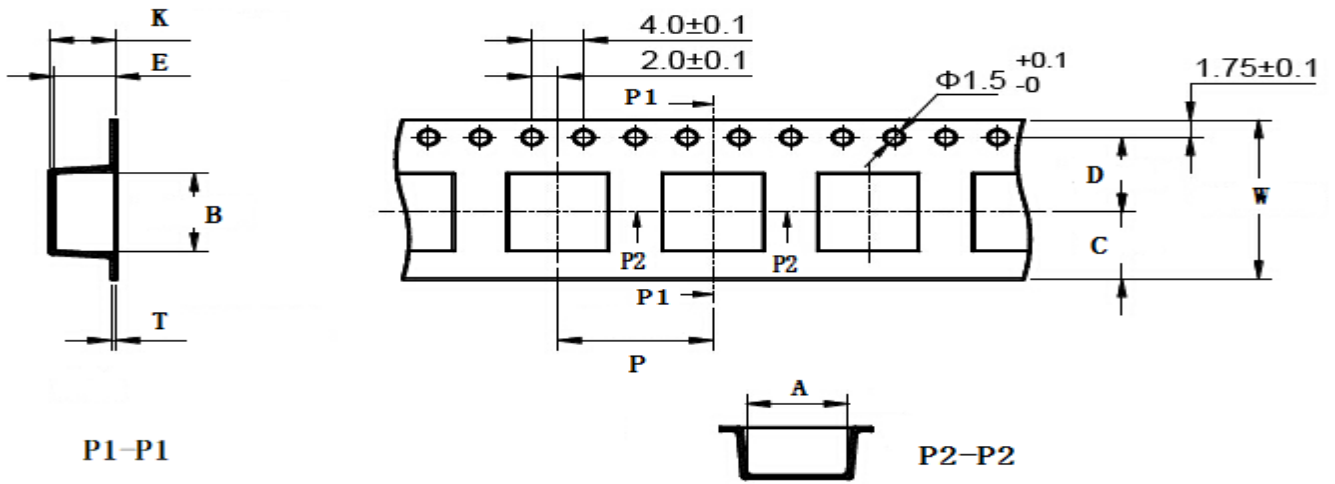

TYPE	W	A	B	C	D	E	P	K Ref	T	MPQ
YSPI0724	16±0.3	7.1±0.1	7.30±0.1	6.75	7.5±0.1	3.4±0.1	12±0.1	2.5	0.40±0.05	1500

■ Reel Dimensions(Unit:mm)

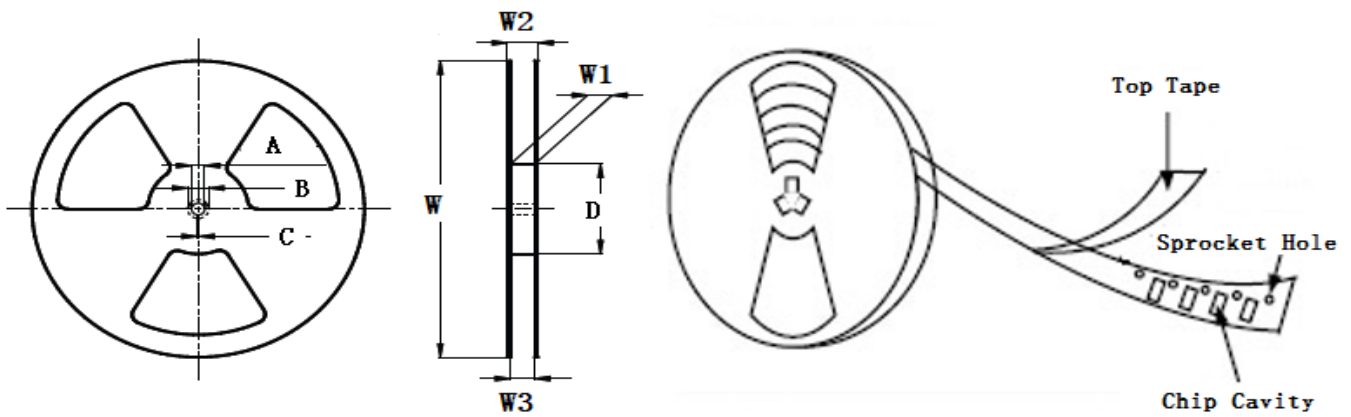

TYPE	W	W1	W2	W3	A	B	C	D
YSPI0724	330±2.0	16.4±2.00	22.4MAX	15.9 Min	13.0±0.50	21.0±0.80	2.0±0.50	100 Min

Direction of rolling

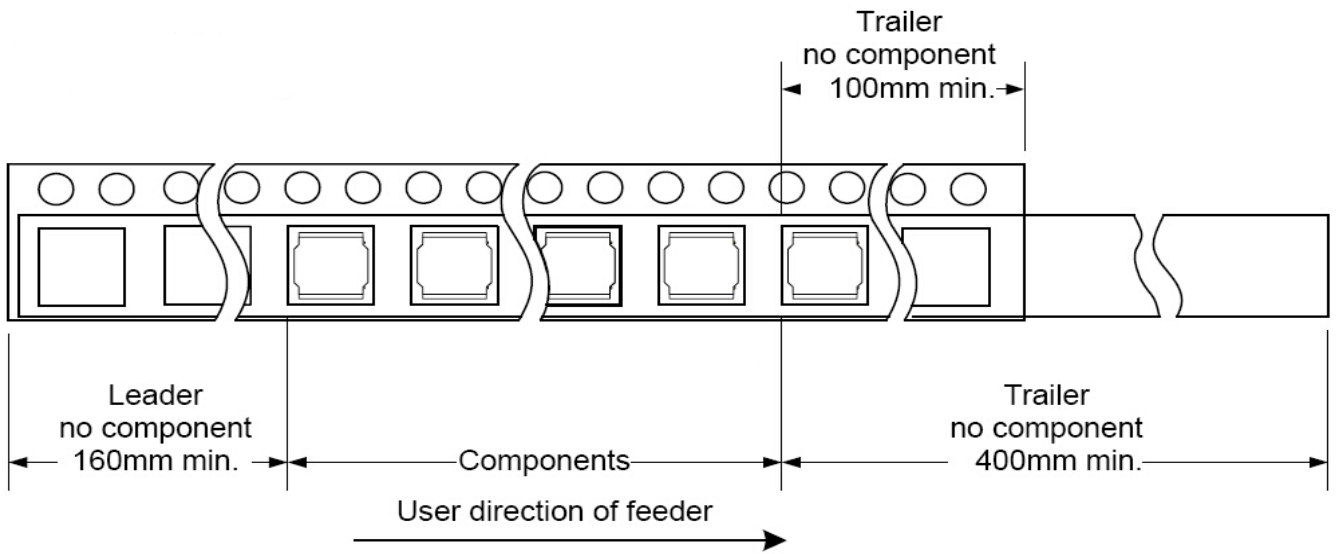

Cover tape peel off condition

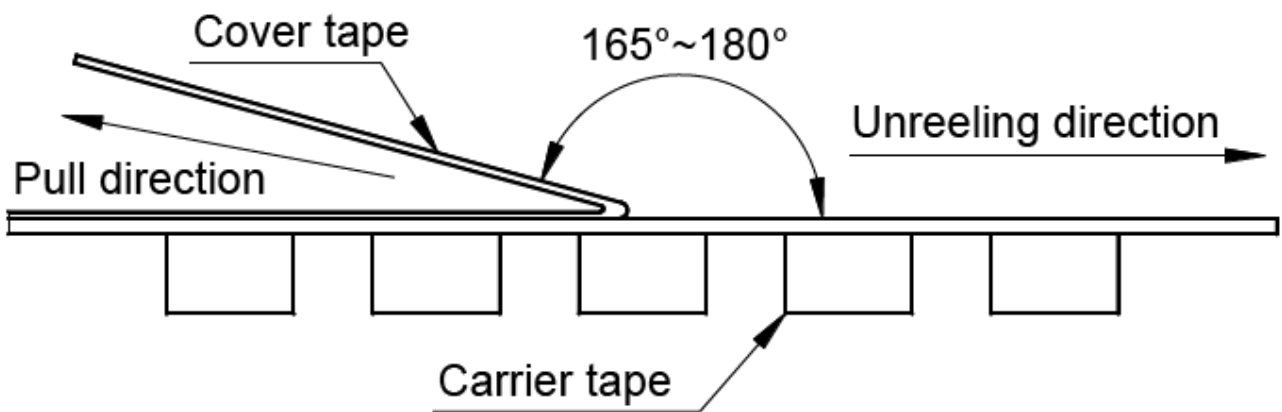

Cover tape peel force shall be 0.1N to 1.3N.

Reference peel speed 300±10mm/min.