

Low Voltage Quad 2-Input OR Gate with 5 V Tolerant Inputs

74LCX32

The LCX32 contains four 2-input OR gates. The inputs tolerate voltages up to 7 V allowing the interface of 5 V systems to 3 V systems.

The 74LCX32 is fabricated with advanced CMOS technology to achieve high speed operation while maintaining CMOS low power dissipation.

Features

- 5 V Tolerant Inputs
- 2.3 V – 3.6 V V_{CC} Specifications Provided
- 5.5 ns t_{PD} Max. ($V_{CC} = 3.3$ V), 10 mA I_{CC} Max.
- Power Down High Impedance Inputs and Outputs
- ± 24 mA Output Drive ($V_{CC} = 3.0$ V)
- Implements Proprietary Noise/EMI Reduction Circuitry
- Latch-up Performance Exceeds JEDEC 78 Conditions
- ESD performance:
 - ◆ Human Body Model >2000 V
 - ◆ Machine model >150 V
- Available on SOIC, TSSOP WB and Leadless QFN Packages
- These are Pb-Free Devices



ON Semiconductor®

www.onsemi.com

MARKING DIAGRAM

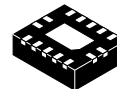

QFN14 3.0x2.5, 0.5P
CASE 510CB

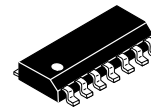

SOIC14
CASE 751EF

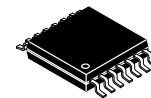
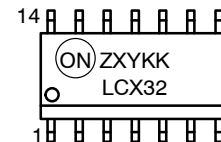

TSSOP-14 WB
CASE 948G

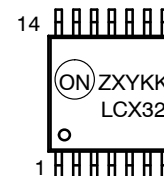

LCX32 = Specific Device Code
 Z = Assembly Plant Code
 XY = Date Code
 KK = Lot Run Traceability Code

ORDERING INFORMATION

See detailed ordering and shipping information on page 8 of this data sheet.

74LCX32

CONNECTION DIAGRAMS

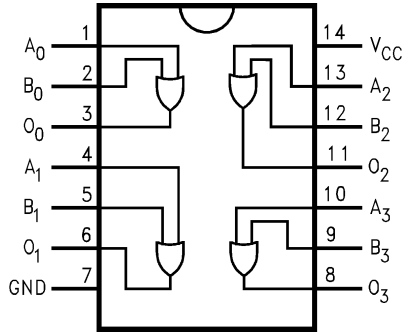

Figure 1. Pin Assignments for SOIC and TSSOP

LOGIC SYMBOL

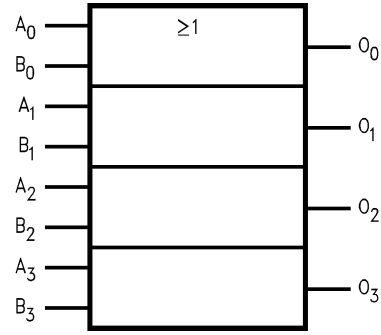

Figure 3. IEEE/IEC

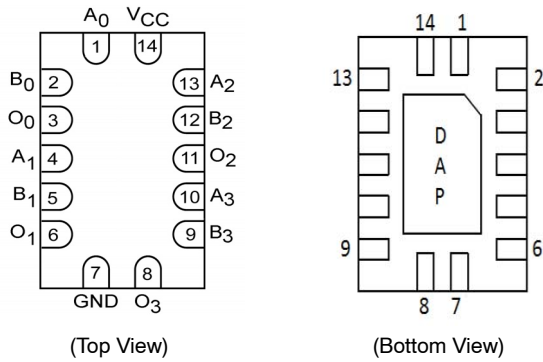

Figure 2. Pad Assignments for DQFN

PIN DESCRIPTION

Pin Names	Description
A_n, B_n	Inputs
O_n	Outputs
DAP	No Connect

1. DAP (Die Attach Pad)

ABSOLUTE MAXIMUM RATINGS

Symbol	Parameter	Rating
V_{CC}	Supply Voltage	-0.5 V to +7.0 V
V_I	DC Input Voltage	-0.5 V to +7.0 V
V_O	DC Output Voltage, Output in HIGH or LOW State (Note 2)	-0.5 V to $V_{CC} + 0.5$ V
I_{IK}	DC Input Diode Current, $V_I < GND$	-50 mA
I_{OK}	DC Output Diode Current $V_O < GND$	-50 mA
	$V_O > V_{CC}$	+50 mA
I_O	DC Output Source/Sink Current	±50 mA
I_{CC}	DC Supply Current per Supply Pin	±100 mA
I_{GND}	DC Ground Current per Ground Pin	±100 mA
T_{STG}	Storage Temperature	-65°C to +150°C

Stresses exceeding those listed in the Maximum Ratings table may damage the device. If any of these limits are exceeded, device functionality should not be assumed, damage may occur and reliability may be affected.

2. I_O Absolute Maximum Rating must be observed.

74LCX32

RECOMMENDED OPERATING CONDITIONS (Note 3)

Symbol	Parameter	Min	Max	Unit
V _{CC}	Supply Voltage Operating	2.0	3.6	V
	Data Retention	1.5	3.6	
V _I	Input Voltage	0	5.5	V
V _O	Output Voltage, HIGH or LOW State	0	V _{CC}	V
I _{OH} / I _{OL}	Output Current V _{CC} = 3.0 V – 3.6 V	–	±24	mA
	V _{CC} = 2.7 V – 3.0 V	–	±12	
	V _{CC} = 2.3 V – 2.7 V	–	±8	
T _A	Free-Air Operating Temperature	–40	85	°C
Δt / ΔV	Input Edge Rate, V _{IN} = 0.8 V – 2.0 V, V _{CC} = 3.0 V	0	10	ns/V

Functional operation above the stresses listed in the Recommended Operating Ranges is not implied. Extended exposure to stresses beyond the Recommended Operating Ranges limits may affect device reliability.

3. Unused inputs must be held HIGH or LOW. They may not float.

DC ELECTRICAL CHARACTERISTICS

Symbol	Parameter	V _{CC} (V)	Conditions	–40°C to 85°C		Unit
				Min	Max	
V _{IH}	HIGH Level Input Voltage	2.3 – 2.7		1.7	–	V
		2.7 – 3.6		2.0	–	
V _{IL}	LOW Level Input Voltage	2.3 – 2.7		–	0.7	V
		2.7 – 3.6		–	0.8	
V _{OH}	HIGH Level Output Voltage	2.3 – 3.6	I _{OH} = –100 μA	V _{CC} – 0.2	–	V
		2.3	I _{OH} = –8 mA	1.8	–	
		2.7	I _{OH} = –12 mA	2.2	–	
		3.0	I _{OH} = –18 mA	2.4	–	
			I _{OH} = –24 mA	2.2	–	
V _{OL}	LOW Level Output Voltage	2.3 – 3.6	I _{OL} = 100 μA	–	0.2	V
		2.3	I _{OL} = 8 mA	–	0.6	
		2.7	I _{OL} = 12 mA	–	0.4	
		3.0	I _{OL} = 16 mA	–	0.4	
			I _{OL} = 24 mA	–	0.55	
I _I	Input Leakage Current	2.3 – 3.6	0 ≤ V _I ≤ 5.5 V	–	±5.0	μA
I _{OFF}	Power-Off Leakage Current	0	V _I or V _O = 5.5 V	–	10	μA
I _{CC}	Quiescent Supply Current	2.3 – 3.6	V _I = V _{CC} or GND	–	10	μA
			3.6 V ≤ V _I ≤ 5.5 V	–	±10	
ΔI _{CC}	Increase in I _{CC} per Input	2.3 – 3.6	V _{IH} = V _{CC} – 0.6 V	–	500	μA

74LCX32

AC ELECTRICAL CHARACTERISTICS

Symbol	Parameter	$T_A = -40^\circ\text{C to } +85^\circ\text{C}, R_L = 500 \Omega$						Unit
		$V_{CC} = 3.3 \text{ V} + 0.3 \text{ V}, C_L = 50 \text{ pF}$		$V_{CC} = 2.7 \text{ V}, C_L = 50 \text{ pF}$		$V_{CC} = 2.5 \text{ V} + 0.2 \text{ V}, C_L = 30 \text{ pF}$		
		Min	Max	Min	Max	Min	Max	
t_{PHL}, t_{PLH}	Propagation Delay	1.5	5.5	1.5	6.2	1.5	6.6	ns
t_{OSHL}, t_{OSLH}	Output to Output Skew (Note 4)	-	1.0	-	-	-	-	ns

4. Skew is defined as the absolute value of the difference between the actual propagation delay for any two separate outputs of the same device. The specification applies to any outputs switching in the same direction, either HIGH-to-LOW (t_{OSHL}) or LOW-to-HIGH (t_{OSLH}).

DYNAMIC SWITCHING CHARACTERISTICS

Symbol	Parameter	V_{CC} (V)	Conditions	$T_A = 25^\circ\text{C}$	Unit
				Typical	
V_{OLP}	Quiet Output Dynamic Peak V_{OL}	3.3	$C_L = 50 \text{ pF}, V_{IH} = 3.3 \text{ V}, V_{IL} = 0 \text{ V}$	0.8	V
		2.5	$C_L = 30 \text{ pF}, V_{IH} = 2.5 \text{ V}, V_{IL} = 0 \text{ V}$	0.6	
V_{OLV}	Quiet Output Dynamic Valley V_{OL}	3.3	$C_L = 50 \text{ pF}, V_{IH} = 3.3 \text{ V}, V_{IL} = 0 \text{ V}$	-0.8	V
		2.5	$C_L = 30 \text{ pF}, V_{IH} = 2.5 \text{ V}, V_{IL} = 0 \text{ V}$	-0.6	

CAPACITANCE

Symbol	Parameter	Conditions	Typical	Unit
C_{IN}	Input Capacitance	$V_{CC} = \text{Open}, V_I = 0 \text{ V or } V_{CC}$	7	pF
C_{OUT}	Output Capacitance	$V_{CC} = 3.3 \text{ V}, V_I = 0 \text{ V or } V_{CC}$	8	pF
C_{PD}	Power Dissipation Capacitance	$V_{CC} = 3.3 \text{ V}, V_I = 0 \text{ V or } V_{CC}, f = 10 \text{ MHz}$	25	pF

AC LOADING AND WAVEFORMS (GENERIC FOR LCX FAMILY)

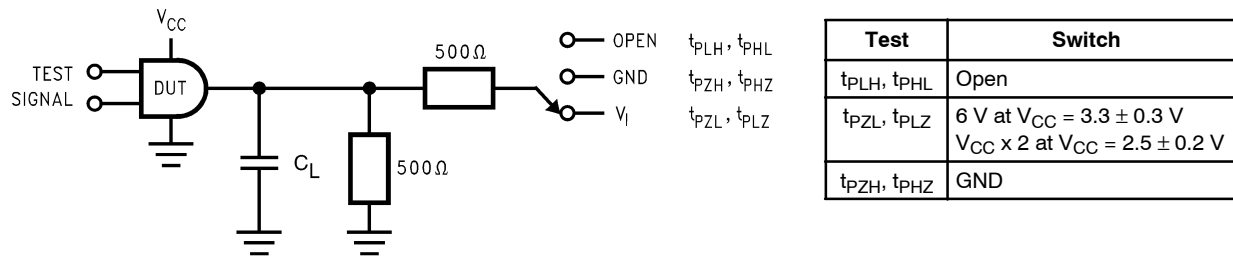
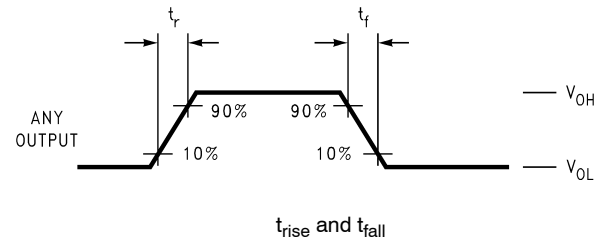
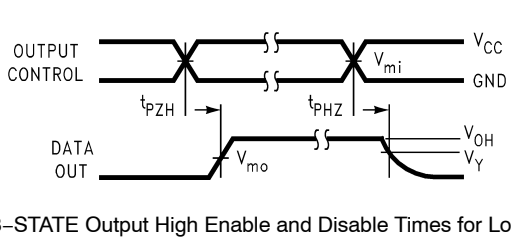
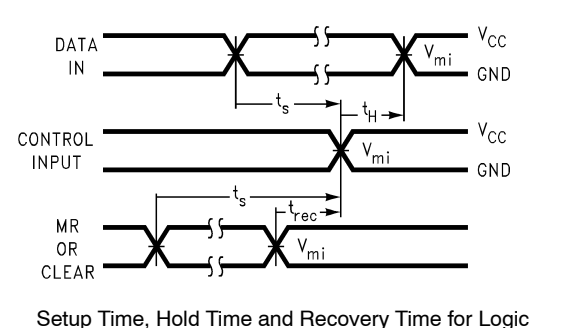
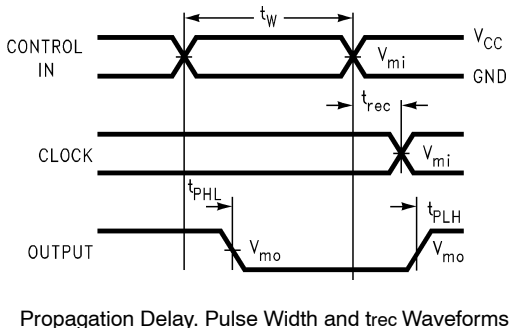
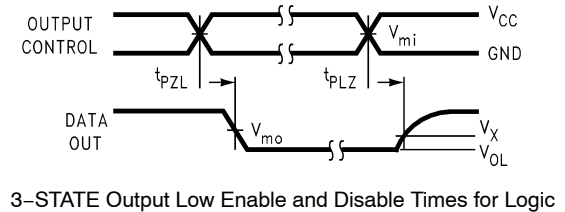
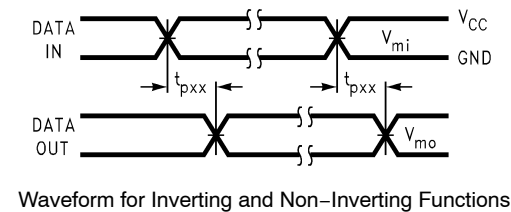

Figure 4. AC Test Circuit (CL Includes Probe and Jig Capacitance)



Symbol	V_{CC}		
	$3.3\text{ V} \pm 0.3\text{ V}$	2.7 V	$2.5\text{ V} \pm 0.2\text{ V}$
V_{mi}	1.5 V	1.5 V	$V_{CC}/2$
V_{mo}	1.5 V	1.5 V	$V_{CC}/2$
V_x	$V_{OL} + 0.3\text{ V}$	$V_{OL} + 0.3\text{ V}$	$V_{OL} + 0.15\text{ V}$
V_y	$V_{OH} - 0.3\text{ V}$	$V_{OH} - 0.3\text{ V}$	$V_{OH} - 0.15\text{ V}$

Figure 5. Waveforms (Input Characteristics; $f = 1\text{ MHz}$, $t_r = t_f = 3\text{ ns}$)

74LCX32

SCHEMATIC DIAGRAM (GENERIC FOR LCX FAMILY)

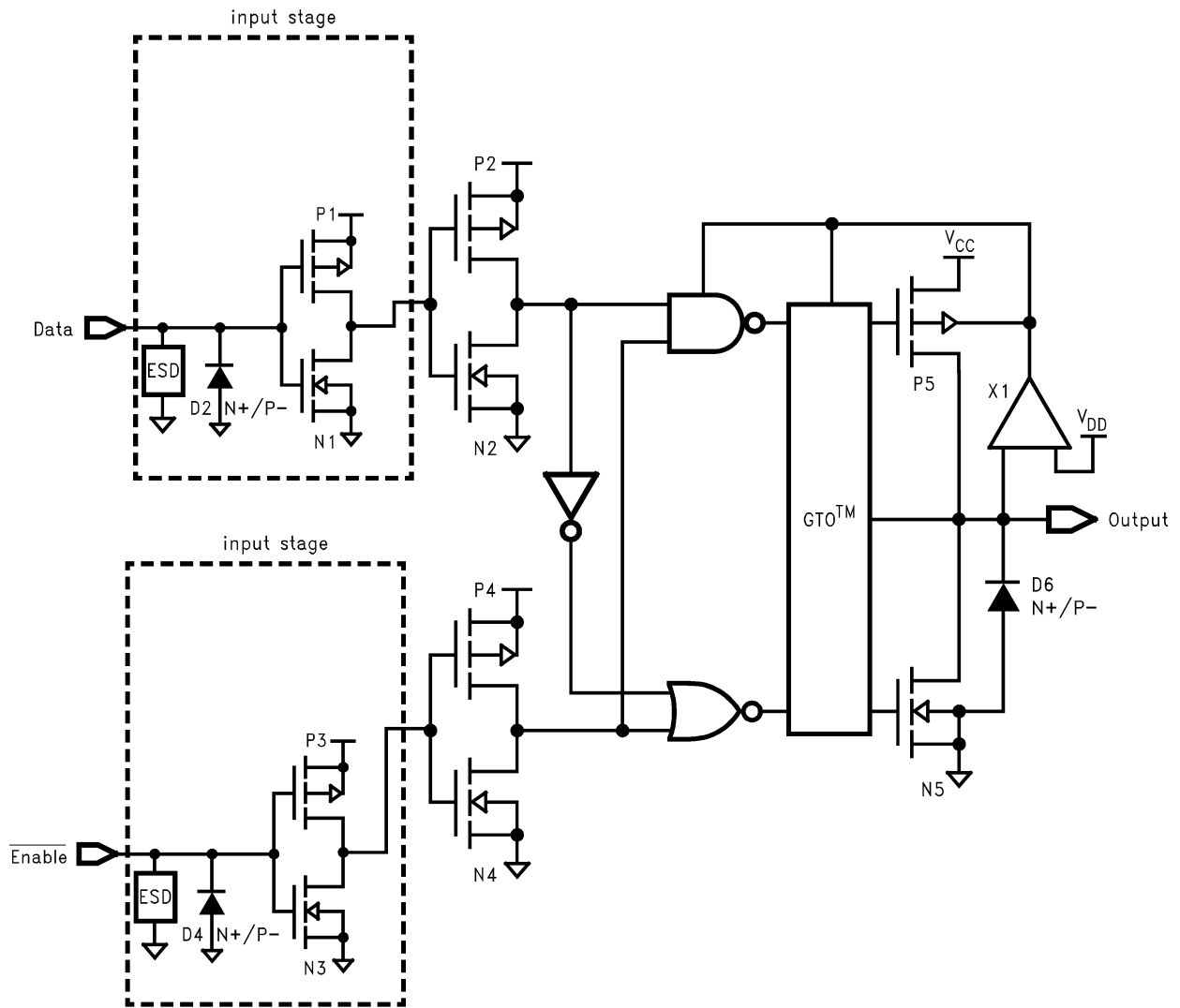

Figure 6. Schematic Diagram (Generic for LCX Family)

74LCX32

TAPE AND REEL SPECIFICATION

Tape Format for DQFN

TAPE FORMAT FOR DQFN

Package Designator	Tape Section	Number of Cavities	Cavity Status	Cover Tape Status
BQX	Leader (Start End)	125 (Typ.)	Empty	Sealed
	Carrier	3000	Filled	Sealed
	Trailer (Hub End)	75 (Typ.)	Empty	Sealed

Tape Dimensions (Inches (Millimeters))

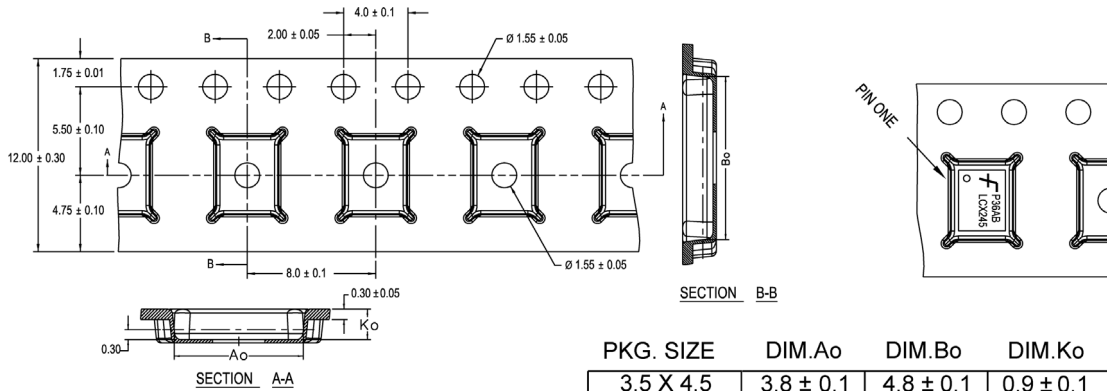

PKG. SIZE	DIM.Ao	DIM.Bo	DIM.Ko
3.5 X 4.5	3.8 ± 0.1	4.8 ± 0.1	0.9 ± 0.1
3.0 X 3.0	3.3 ± 0.1	3.3 ± 0.1	0.9 ± 0.1
2.5 X 4.5	2.8 ± 0.1	4.8 ± 0.1	0.9 ± 0.1
2.5 X 3.5	2.8 ± 0.1	3.8 ± 0.1	0.9 ± 0.1
2.5 X 3.0	2.8 ± 0.1	3.3 ± 0.1	0.9 ± 0.1
2.5 X 2.5	2.8 ± 0.1	2.8 ± 0.1	0.9 ± 0.1

DIMENSIONS ARE IN MILLIMETERS

NOTES: unless otherwise specified

1. Cumulative pitch for feeding holes and cavities (chip pockets) not to exceed 0.008[0.20] over 10 pitch span.
2. Smallest allowable bending radius.
3. Thru hole inside cavity is centered within cavity.
4. Tolerance is ± 0.002 [0.05] for these dimensions on all 12mm tapes.
5. Ao and Bo measured on a plane 0.120[0.30] above the bottom of the pocket.
6. Ko measured from a plane on the inside bottom of the pocket to the top surface of the carrier.
7. Pocket position relative to sprocket hole measured as true position of pocket. Not pocket hole.
8. Controlling dimension is millimeter. Dimension in inches rounded.

Figure 7. Tape Dimensions (Inches (Millimeters))

74LCX32

Reel Dimensions (Inches (Millimeters))

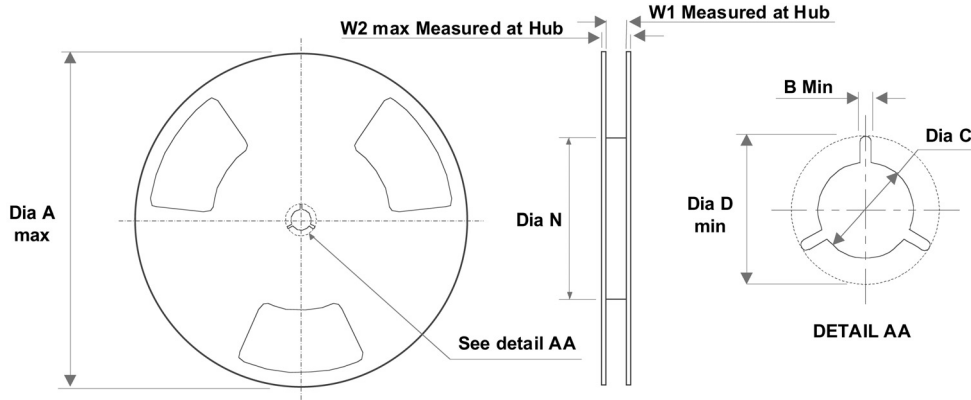

Figure 8.

Tape Size	A	B	C	D	N	W1	W2
12 mm	13.0 (330.0)	0.059 (1.50)	0.512 (13.00)	0.795 (20.20)	2.165 (55.00)	0.488 (12.4)	0.724 (18.4)

ORDERING INFORMATION

Ordering Number	Package Number	Package Description	Shipping [†]
74LCX32M	SOIC14	14-Lead Small Outline Integrated Circuit (SOIC), JEDEC MS-012, 0.150" Narrow	1100 Units / Tube
74LCX32BQX (Note 5)	QFN14	14-Terminal Depopulated Quad Very-Thin Flat Pack No Leads (DQFN), JEDEC MO-241, 2.5 x 3.0 mm	3000 Units / Tape & Reel
74LCX32MTC	TSSOP-14 WB	14-Lead Thin Shrink Small Outline Package (TSSOP), JEDEC MO-153, 4.4 mm Wide	2350 Units / Tube
74LCX32MTCX	TSSOP-14 WB	14-Lead Thin Shrink Small Outline Package (TSSOP), JEDEC MO-153, 4.4 mm Wide	2500 Units / Tape & Reel

[†]For information on tape and reel specifications, including part orientation and tape sizes, please refer to our Tape and Reel Packaging Specifications Brochure, BRD8011/D.

5. DQFN package available in Tape and Reel only.

6. Device also available in Tape and Reel. Specify by appending suffix letter "X" to the ordering number.

7. All packages are lead free per JEDEC: J-STD-020B standard.

MECHANICAL CASE OUTLINE

PACKAGE DIMENSIONS

ON Semiconductor®



QFN14 3.0x2.5, 0.5P
CASE 510CB
ISSUE O

DATE 31 AUG 2016

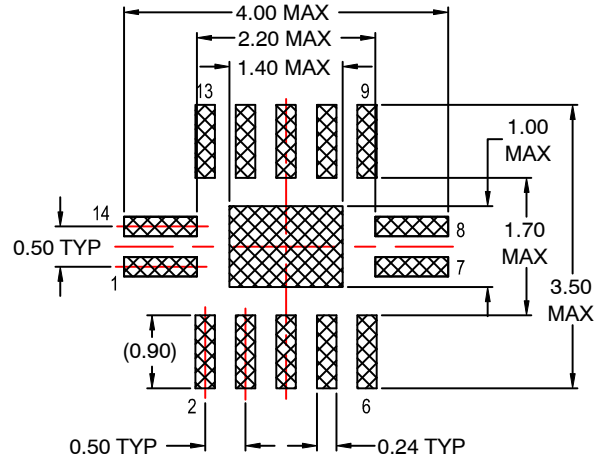
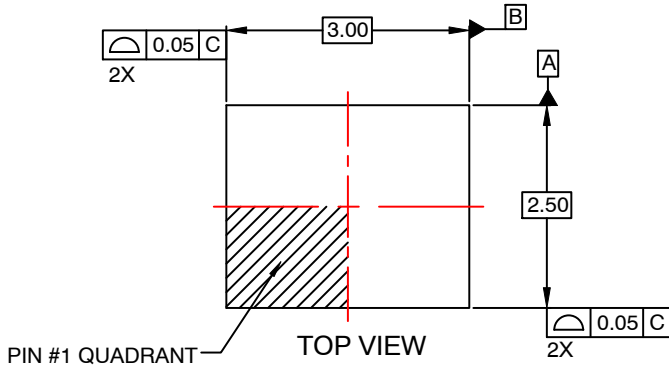

RECOMMENDED LAND PATTERN

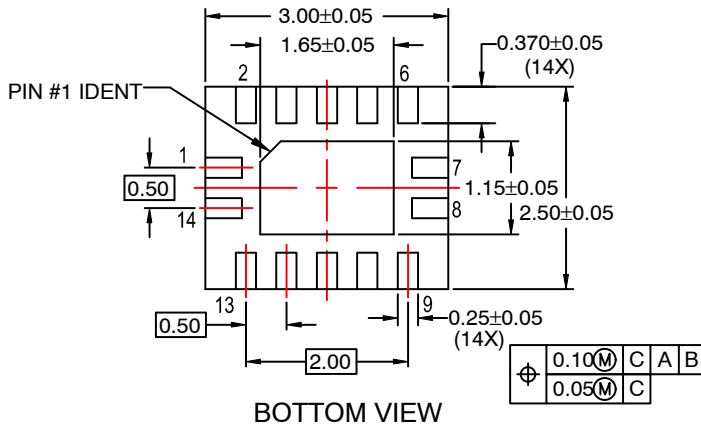
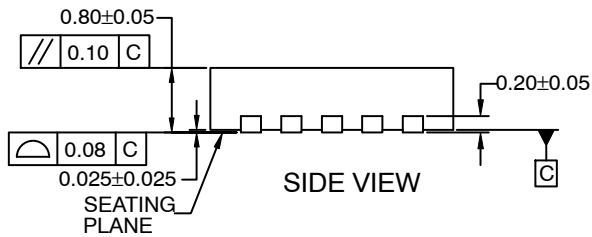

NOTES:

- A. CONFORMS TO JEDEC REGISTRATION MO-241, VARIATION AA
- B. DIMENSIONS ARE IN MILLIMETERS.
- C. DIMENSIONS AND TOLERANCES PER ASME Y14.5M, 2009.
- D. LAND PATTERN RECOMMENDATION IS EXISTING INDUSTRY LAND PATTERN.

DOCUMENT NUMBER:	98AON13643G	Electronic versions are uncontrolled except when accessed directly from the Document Repository. Printed versions are uncontrolled except when stamped "CONTROLLED COPY" in red.
DESCRIPTION:	QFN14 3.0X2.5, 0.5P	PAGE 1 OF 1

ON Semiconductor and are trademarks of Semiconductor Components Industries, LLC dba ON Semiconductor or its subsidiaries in the United States and/or other countries. ON Semiconductor reserves the right to make changes without further notice to any products herein. ON Semiconductor makes no warranty, representation or guarantee regarding the suitability of its products for any particular purpose, nor does ON Semiconductor assume any liability arising out of the application or use of any product or circuit, and specifically disclaims any and all liability, including without limitation special, consequential or incidental damages. ON Semiconductor does not convey any license under its patent rights nor the rights of others.

MECHANICAL CASE OUTLINE
PACKAGE DIMENSIONS

ON Semiconductor®



SOIC14
CASE 751EF
ISSUE O

DATE 30 SEP 2016

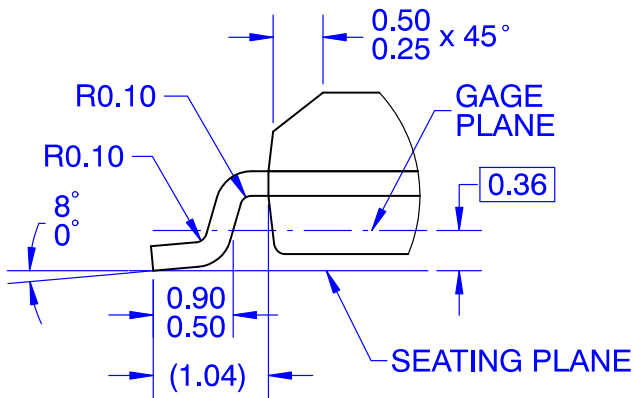
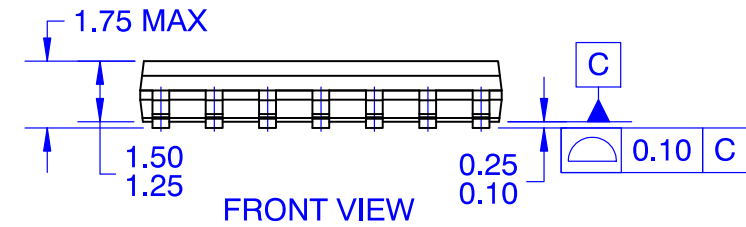
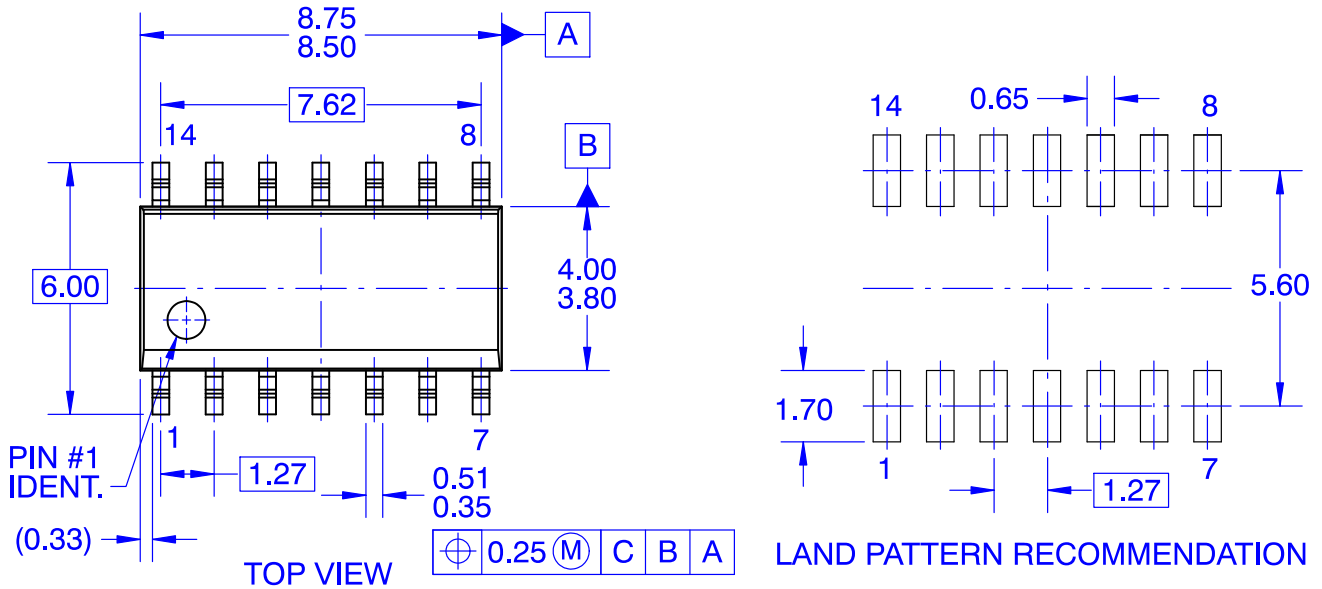

NOTES:

- A. CONFORMS TO JEDEC MS-012, VARIATION AB, ISSUE C
- B. ALL DIMENSIONS ARE IN MILLIMETERS
- C. DIMENSIONS DO NOT INCLUDE MOLD FLASH OR BURRS
- D. LAND PATTERN STANDARD: SOIC127P600X145-14M
- E. CONFORMS TO ASME Y14.5M, 2009

DOCUMENT NUMBER:	98AON13739G	Electronic versions are uncontrolled except when accessed directly from the Document Repository. Printed versions are uncontrolled except when stamped "CONTROLLED COPY" in red.
DESCRIPTION:	SOIC14	PAGE 1 OF 1

ON Semiconductor and are trademarks of Semiconductor Components Industries, LLC dba ON Semiconductor or its subsidiaries in the United States and/or other countries. ON Semiconductor reserves the right to make changes without further notice to any products herein. ON Semiconductor makes no warranty, representation or guarantee regarding the suitability of its products for any particular purpose, nor does ON Semiconductor assume any liability arising out of the application or use of any product or circuit, and specifically disclaims any and all liability, including without limitation special, consequential or incidental damages. ON Semiconductor does not convey any license under its patent rights nor the rights of others.

MECHANICAL CASE OUTLINE PACKAGE DIMENSIONS



TSSOP-14 WB
CASE 948G
ISSUE C

DATE 17 FEB 2016

SCALE 2:1



NOTES:

- DIMENSIONING AND TOLERANCING PER ANSI Y14.5M, 1982.
- CONTROLLING DIMENSION: MILLIMETER.
- DIMENSION A DOES NOT INCLUDE MOLD FLASH, PROTRUSIONS OR GATE BURRS. MOLD FLASH OR GATE BURRS SHALL NOT EXCEED 0.15 (0.006) PER SIDE.
- DIMENSION B DOES NOT INCLUDE INTERLEAD FLASH OR PROTRUSION. INTERLEAD FLASH OR PROTRUSION SHALL NOT EXCEED 0.25 (0.010) PER SIDE.
- DIMENSION K DOES NOT INCLUDE DAMBAR PROTRUSION. ALLOWABLE DAMBAR PROTRUSION SHALL BE 0.08 (0.003) TOTAL IN EXCESS OF THE K DIMENSION AT MAXIMUM MATERIAL CONDITION.
- TERMINAL NUMBERS ARE SHOWN FOR REFERENCE ONLY.
- DIMENSION A AND B ARE TO BE DETERMINED AT DATUM PLANE -W-.

DIM	MILLIMETERS		INCHES	
	MIN	MAX	MIN	MAX
A	4.90	5.10	0.193	0.200
B	4.30	4.50	0.169	0.177
C	---	1.20	---	0.047
D	0.05	0.15	0.002	0.006
F	0.50	0.75	0.020	0.030
G	0.65 BSC		0.026 BSC	
H	0.50	0.60	0.020	0.024
J	0.09	0.20	0.004	0.008
J1	0.09	0.16	0.004	0.006
K	0.19	0.30	0.007	0.012
K1	0.19	0.25	0.007	0.010
L	6.40 BSC		0.252 BSC	
M	0°	8°	0°	8°

GENERIC MARKING DIAGRAM*



- A = Assembly Location
- L = Wafer Lot
- Y = Year
- W = Work Week
- = Pb-Free Package

(Note: Microdot may be in either location)

*This information is generic. Please refer to device data sheet for actual part marking. Pb-Free indicator, "G" or microdot "▪", may or may not be present. Some products may not follow the Generic Marking.

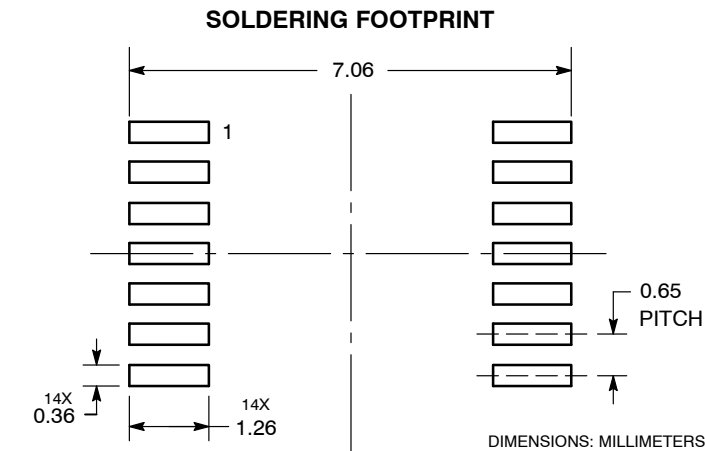

DOCUMENT NUMBER:	98ASH70246A	Electronic versions are uncontrolled except when accessed directly from the Document Repository. Printed versions are uncontrolled except when stamped "CONTROLLED COPY" in red.
DESCRIPTION:	TSSOP-14 WB	PAGE 1 OF 1

onsemi and onsemi are trademarks of Semiconductor Components Industries, LLC dba onsemi or its subsidiaries in the United States and/or other countries. onsemi reserves the right to make changes without further notice to any products herein. onsemi makes no warranty, representation or guarantee regarding the suitability of its products for any particular purpose, nor does onsemi assume any liability arising out of the application or use of any product or circuit, and specifically disclaims any and all liability, including without limitation special, consequential or incidental damages. onsemi does not convey any license under its patent rights nor the rights of others.

onsemi, **Onsemi**, and other names, marks, and brands are registered and/or common law trademarks of Semiconductor Components Industries, LLC dba "**onsemi**" or its affiliates and/or subsidiaries in the United States and/or other countries. **onsemi** owns the rights to a number of patents, trademarks, copyrights, trade secrets, and other intellectual property. A listing of **onsemi**'s product/patent coverage may be accessed at www.onsemi.com/site/pdf/Patent-Marking.pdf. **onsemi** reserves the right to make changes at any time to any products or information herein, without notice. The information herein is provided "as-is" and **onsemi** makes no warranty, representation or guarantee regarding the accuracy of the information, product features, availability, functionality, or suitability of its products for any particular purpose, nor does **onsemi** assume any liability arising out of the application or use of any product or circuit, and specifically disclaims any and all liability, including without limitation special, consequential or incidental damages. Buyer is responsible for its products and applications using **onsemi** products, including compliance with all laws, regulations and safety requirements or standards, regardless of any support or applications information provided by **onsemi**. "Typical" parameters which may be provided in **onsemi** data sheets and/or specifications can and do vary in different applications and actual performance may vary over time. All operating parameters, including "Typicals" must be validated for each customer application by customer's technical experts. **onsemi** does not convey any license under any of its intellectual property rights nor the rights of others. **onsemi** products are not designed, intended, or authorized for use as a critical component in life support systems or any FDA Class 3 medical devices or medical devices with a same or similar classification in a foreign jurisdiction or any devices intended for implantation in the human body. Should Buyer purchase or use **onsemi** products for any such unintended or unauthorized application, Buyer shall indemnify and hold **onsemi** and its officers, employees, subsidiaries, affiliates, and distributors harmless against all claims, costs, damages, and expenses, and reasonable attorney fees arising out of, directly or indirectly, any claim of personal injury or death associated with such unintended or unauthorized use, even if such claim alleges that **onsemi** was negligent regarding the design or manufacture of the part. **onsemi** is an Equal Opportunity/Affirmative Action Employer. This literature is subject to all applicable copyright laws and is not for resale in any manner.

PUBLICATION ORDERING INFORMATION

LITERATURE FULFILLMENT:

Email Requests to: orderlit@onsemi.com

onsemi Website: www.onsemi.com

TECHNICAL SUPPORT

North American Technical Support:

Voice Mail: 1 800-282-9855 Toll Free USA/Canada

Phone: 011 421 33 790 2910

Europe, Middle East and Africa Technical Support:

Phone: 00421 33 790 2910

For additional information, please contact your local Sales Representative