

Liner Vibrator Driver IC

CMOS LSI

LC898301XA

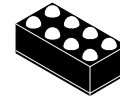

WLCSP8, 0.78 x 1.58
CASE 567HA

Overview

The LC898301XA is a Linear Vibrator Driver IC dedicated to haptic feedback actuator and vibrator employed in mobile equipment. Due to the product superior technology, the drive frequency is automatically adjusted to the resonance frequency of the linear vibrator without the use of other external parts. As a result of this very effective drive, the vibration is as powerful as possible using very limited amount of energy compared to classical solutions.

The start time and brake time are fully configurable through the I²C setting. Moreover, an automatic braking function has been implemented allowing to optimize the braking time.

Finally, a self test mode allows to detect various possible functional defaults during assembly.

Features

- Automatic Adjustment to the Resonance Frequency for LRA (150 Hz to 385 Hz)
- Programmable or Automatic Braking
- Initial Drive Frequency Adjustment Function
- Adjustable Drive Voltage through I²C IF Setting
- EN IF or PWM IF Driving Mode Available by Automatic Detection
- Support Various Drive Pattern through I²C (1.8 V IF)
- Low Power Consumption Thanks to the Highly Effective Drive and the Low Power Driving Mode
- Low Driving Noise (EMI, Audible Band)
- VBAT Compliant
- Thermal Shutdown Protection
- Self Test Mode for Defaults Detection (Open-circuit, Short-circuit and Weak Back EMF)
- This is a Pb-Free and Halogen Free Device

Applications

- Linear Vibrator (Vibration and Haptics)
- Mobile Phone
- Portable Game
- Mobile Equipment with Haptics Function

MARKING DIAGRAM

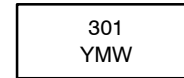

301 = Specific Device Code
Y = Year
M = Month
W = Week

ORDERING INFORMATION

Device	Package	Shipping [†]
LC898301XA-MH	WLCSP8 (Pb-Free)	5000 / Tape & Reel

[†]For information on tape and reel specifications, including part orientation and tape sizes, please refer to our Tape and Reel Packaging Specification Brochure, BRD8011/D.

LC898301XA

BLOCK DIAGRAM

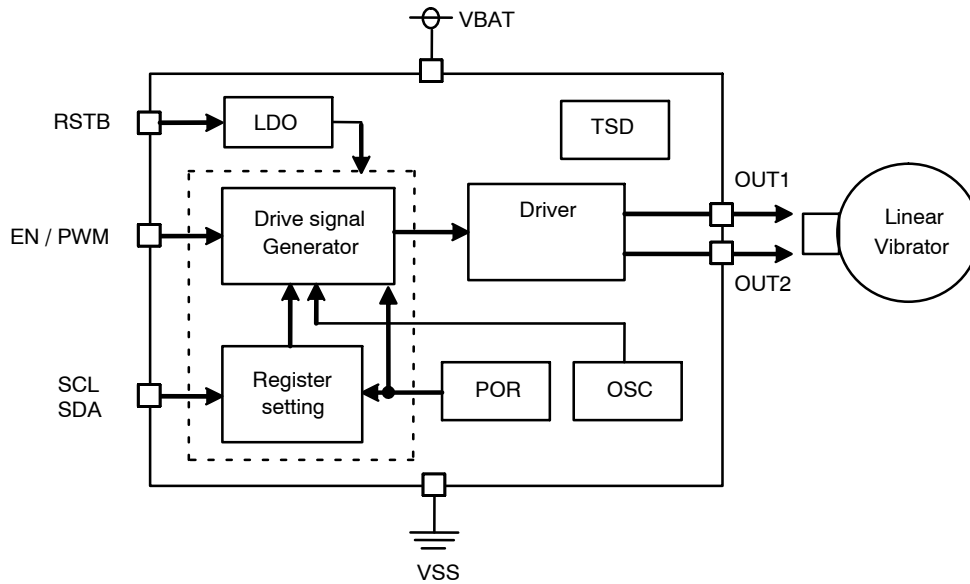

Figure 1. Block Diagram

ABSOLUTE MAXIMUM RATINGS ($V_{SS} = 0\text{ V}$)

Parameter	Symbol	Condition	Rating	Unit
Supply Voltage Range	V_{DDmax}		-0.3 to 6.0	V
Input Voltage	V_{I1}	(Note 1)	-0.3 to $V_{DD} + 0.3$	V
	V_{I2}	(Note 2)	-0.3 to 3.3	V
Output Voltage	V_O	(Note 3)	-0.3 to 3.3	V
H-bridge Drive Current	I_{Omax}		200	mA
Allowable Power Dissipation	PD_{max}	$T_a = 85^\circ\text{C}$ (Note 4)	140	mW
Operating Temperature Range	T_a		-30 to 85	$^\circ\text{C}$
Storage Temperature Range	T_{stsg}		-55 to 125	$^\circ\text{C}$
Input or Output Current	I_I, I_O	(Note 5)	± 20	mA

Stresses exceeding those listed in the Maximum Ratings table may damage the device. If any of these limits are exceeded, device functionality should not be assumed, damage may occur and reliability may be affected.

RECOMMENDED OPERATING CONDITIONS ($T_a = -30$ to 85°C , $V_{CC} = 0\text{ V}$)

Parameter	Symbol	Condition	Min	Max	Unit
Supply Voltage Range	V_{DD}		3.0	5.5	V
Input Voltage Range	V_{IN1}	(Note 1)	0	V_{DD}	V
	V_{IN2}	(Note 2)	0	1.98	V

Functional operation above the stresses listed in the Recommended Operating Ranges is not implied. Extended exposure to stresses beyond the Recommended Operating Ranges limits may affect device reliability.

1. RSTB pin.
2. EN, SDA, SCL pins.
3. SDA pin.
4. Glass epoxy (50 mm × 40mm, t = 0.9 mm, FR-4).
5. Per an I/O buffer.

LC898301XA

ELECTRIC CHARACTERISTICS

DC CHARACTERISTICS ($V_{SS} = 0\text{ V}$, $V_{DD} = 3.0\text{ to }5.5\text{ V}$, $T_a = -30\text{ to }85^\circ\text{C}$)

Parameter	Symbol	Conditions	Min	Typ	Max	Unit	Applicable Pins
High Level Input Voltage	V_{IH}	CMOS	1.40	–	–	V	EN
Low Level Input Voltage	V_{IL}		–	–	0.32	V	
High Level Input Voltage	V_{IH}	CMOS Schmitt	1.50	–	–	V	SDA, SCL
Low Level Input Voltage	V_{IL}		–	–	0.24	V	
High Level Input Voltage	V_{IH}	CMOS Schmitt	1.50	–	–	V	RSTB
Low Level Input Voltage	V_{IL}		–	–	0.36	V	
Low Level Output Voltage	V_{OL}	$I_{OL} = 4\text{ mA}$	–	–	0.4	V	SDA
Input Leakage Current	I_{IL}	$V_I = V_{DD}, V_{SS}$	–10	–	+10	μA	RSTB, EN, SDA, SCL

AC INPUT CHARACTERISTICS ($V_{SS} = 0\text{ V}$, $V_{DD} = 3.0\text{ to }5.5\text{ V}$, $T_a = -30\text{ to }85^\circ\text{C}$)

Parameter	Symbol	Condition	Min	Typ	Max	Unit
Input PWM Frequency	f_{frq}	1% < PWM Duty < 99%	10.0	–	50.0	kHz

POWER CONSUMPTION ($V_{SS} = 0\text{ V}$, $V_{DD} = 3.0\text{ to }5.5\text{ V}$, $T_a = 25^\circ\text{C}$)

Parameter	Symbol	Condition	Min	Typ	Max	Unit
Stand-by Current	P_{stb}	RSTB = "0"	–	0.04	2.0	μA
Idle Current	P_{idl}	RSTB = "1", EN = "0"	–	2.7	–	mA

ANALOG CHARACTERISTICS ($V_{SS} = 0\text{ V}$, $V_{DD} = 3.7\text{ V}$, $T_a = 25^\circ\text{C}$)

Parameter	Symbol	Condition	Min	Typ	Max	Unit
Output Voltage Difference OUT1 from OUT2	V_{out12}	HBPW = max, VOSEL = "00"	–	2.7	–	V _{pp}
		HBPW = max, VOSEL = "01"	–	2.9	–	V _{pp}
Adjustable Resonance Frequency Range	F_{mo}	vs typ value	–10	–	+10	%

Product parametric performance is indicated in the Electrical Characteristics for the listed test conditions, unless otherwise noted. Product performance may not be indicated by the Electrical Characteristics if operated under different conditions.

LC898301XA

PIN ASSIGNMENT

PIN LIST

No	Name	I/O	No	Name	I/O
1A	OUT1	O	1B	VDD	P
2A	OUT2	O	2B	RSTB	I
3A	GND	P	3B	EN	I
4A	SCL	I	4B	SDA	B

NOTE: I/O → I : input, O: output, B: bi-direction, P: power supply, NC: not connected

Pin Layout (PKG: WLP8, 0.4 mm pitch)

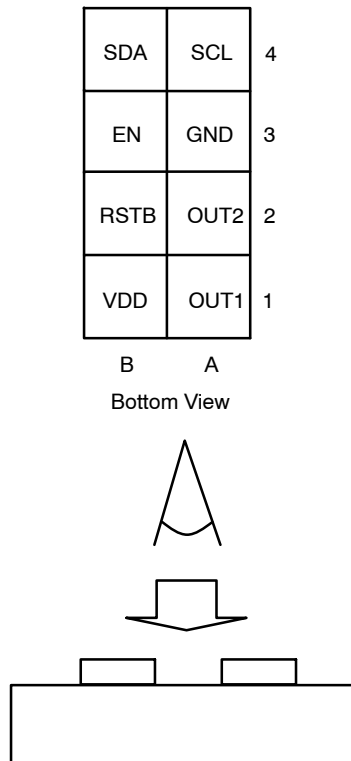

Figure 2. Pin Layout

PIN DESCRIPTION

Signal Name	I/O	Function	Remarks
OUT1	O	Motor drive pin	H-bridge output
OUT2	O	Motor drive pin	H-bridge output
RSTB	I	Reset and Standby control	L : enable, H : disable
EN	I	Motor drive ON/OFF	EN control or PWM control input
SCL	I	I ² C I/F clock pin	
SDA	B	I ² C I/F data pin	Open drain
VDD	P	Power supply pin	
VSS	P	GND pin	

NOTE: I/O → I : input, O: output, B: bi-direction, P: power supply, NC: not connected

TIMING CHART

Motor Drive Timing

The EN or PWM input mode is detected automatically after RSTB pin is set to "H". IF the input mode detection is completed, the result is maintained until RSTB is set to "L".

EN Control Mode

The Motor is controlled by EN signal, and the driving time is controlled by keeping EN pin "H". The High speed start UP time, driving power and Brake time can be modified by I²C setting. The initial driving frequency must be set by I²C I/F at the center of resonance frequency of the linear vibrators, when the initial driving frequency is inadequate. The minimum width of EN signal must be larger than the cycle of initial driving frequency setting.

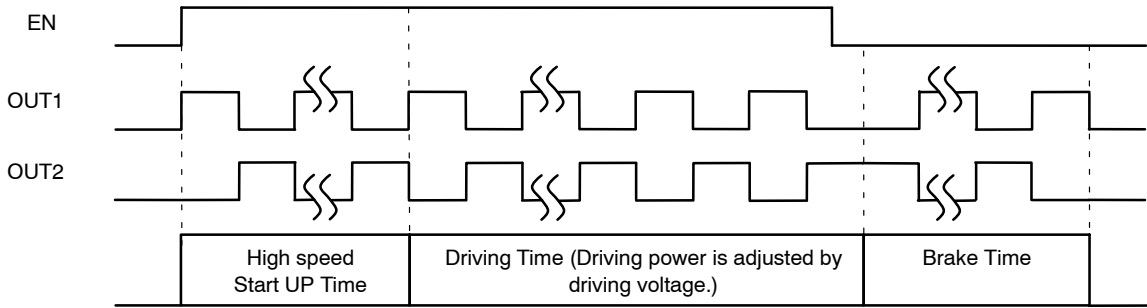

Figure 3.

Stand-by Control (EN Control Mode)

The Stand-by mode is controlled by RSTB pin. (RSTB="L" → Stand-by mode is ON.)

When the stand-by mode is "ON", the register value is set to initial value. So, the register must be set again after the stand-by mode is "OFF". And, the "EN" signal and I²C command must wait over 200 μs after "RSTB" pin is set to "H".

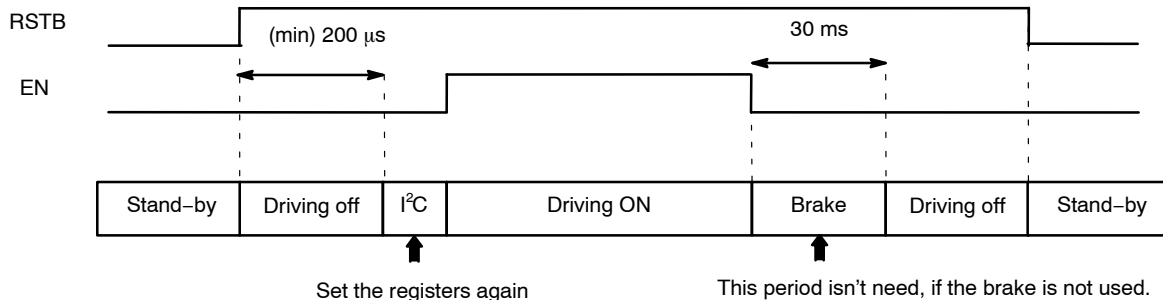

Figure 4.

EN Control

The minimum time of EN = "H" is (1/ the frequency: RESOFRQ), ex) 0 x 02 RESOFRQ = 0 x 0 A (175 Hz) → (min) 5.71 ms
 EN = "L" just after EN = "H" means brake works. So the minimum time of EN = "L" depends on the remains of vibration. Then when drive time until just before EN = "L"(time of EN= "H" before EN = "L") is over 30 ms, the minimum time of EN - "L" is 30 ms.

When drive time until just before EN = "L"(time of EN = "H" before EN = "L") is less than 30 ms, the minimum time of EN = "L" is the same time as drive time until just before EN = "L".

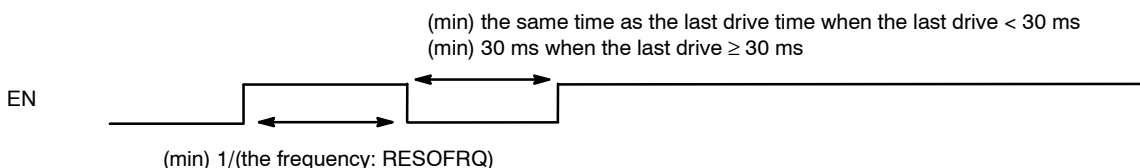

Figure 5.

PWM Control Mode

On this mode the motor is controlled by “PWM” signal, and it is automatically detected. The driving or brake mode is judged by the duty of “PWM” signal. Also the driving power is judged by it. The judgment rule is decided by the table as below. On this mode, 0 × 05 to 0 × 09 registers are available, and the PWM input duty is limited between 1% to 99%. When the duty is 0%, the driving is stopped.

NOTES: PWM input frequency must be set 128*(Resonance frequency of LRA) in case 0 × 08: RFSEL is set to “0”.
 The actual driving frequency of the LRA is calculated by Auto Tune function.
 The period of input PWM detection is about 170 μs after a signal input.

Duty (%)	Driving Mode	Resolution
99.00 to 50.39	Forward	127 steps
50.39 to 49.62	Stop	-
49.62 to 1.00	Reverse	127 steps

NOTE: Duty: 99.0% is maximum driving, on the other hand, Duty: 1.0% is maximum braking.

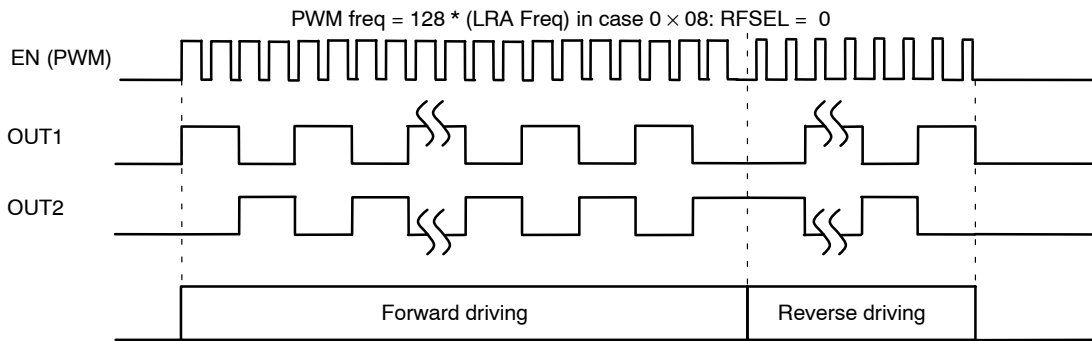

Figure 6.

Stand-by Control (PWM Control Mode)

The Stand-by mode is controlled by RSTB pin. (RSTB=“L” → Stand-by mode is ON.)
 When the stand-by mode is “ON”, the register value is set to initial value. So, the register must be set again after the stand-by mode is “OFF”. And, the “EN” signal and I²C command must wait over 200 μs after “RSTB” pin is set to “H”.

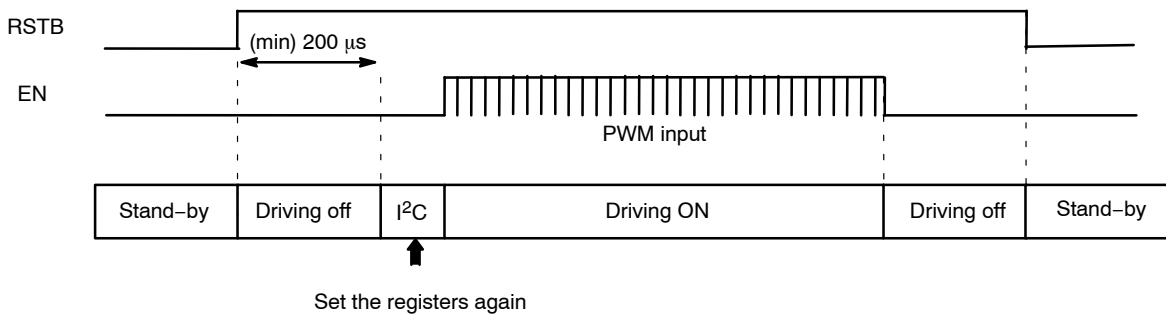

Figure 7.

I²C Serial Interface

Writing Format (Sequential Writing is Possible)

After the start condition, slave address (7bit) and “L”(Write mode) are received , the flag “ACK = L” is replied. Next, after the 8 bit address is received, the flag “ACK = L” is replied. Next, after the 8 bit write data is received, the flag “ACK = L” is replied. Next, when the stop condition is received, the write data can be written in the specified address. Moreover, it is possible to write data in the incremental address by the continuous input of the 8 bit data confirming the flag “ACK = L” after the every 8 bit write data input.

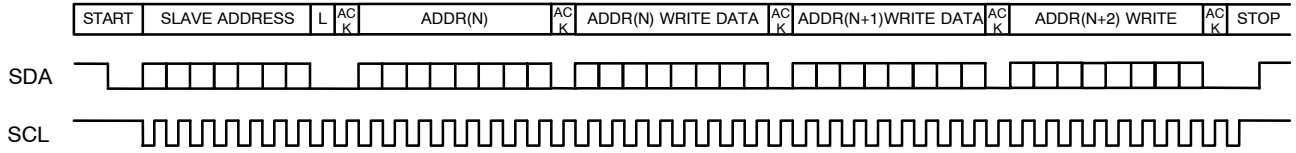

Figure 8.

Reading Format (Sequential Reading is Possible)

After the dummy writing, the start condition, slave address (7 bit) and “H”(Read mode) are received, the flag “ACK = L” is replied. Next, the 8 bit read data is output. After them, when the stop condition is not received, and the read condition is continued, the read data of incremental address is output one by one. The read condition is end when the end condition is received after the flag “ACK = H”.

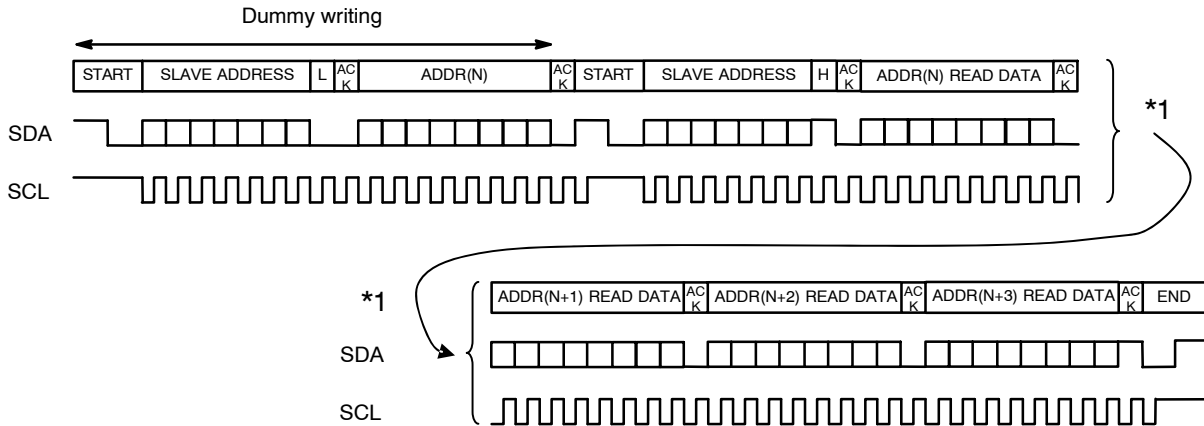

Figure 9.

Slave Address

The Slave Address is as follows.

Slave Address	1001001
---------------	---------

LC898301XA

AC CHARACTERISTICS (I²C SERIAL INTERFACE) ($V_{SS} = 0\text{ V}$, $V_{DD} = 3.0\text{ to }5.5\text{ V}$, $T_A = -30\text{ to }85^\circ\text{C}$)

Parameter	Symbol	Pin	Min	Typ	Max	Unit	Comment
SCL Clock Frequency	f_{SCL}	SCL	–	–	400	kHz	
START Condition Hold Time	$t_{HD; STA}$	SCL SDA	0.6	–	–	μs	
SCL Clock Low Width	t_{LOW}	SCL	1.3	–	–	μs	
SCL Clock High Width	t_{HIGH}	SCL	0.6	–	–	μs	
RE-START Condition Setup Time	$t_{SU; STA}$	SCL SDA	0.6	–	–	μs	
SDA Hold Time	$t_{HD; DAT}$	SCL SDA	0	–	–	μs	
SDA Setup Time	$t_{SU; DAT}$	SCL SDA	0.2	–	–	μs	(Note 6)
SDA, SCL Rise Time	t_r	SCL SDA	–	–	0.3	μs	(Note 6)
SDA, SCL Fall Time	t_f	SCL SDA	–	–	0.3	μs	(Note 6)
STOP Condition Setup Time	$t_{SU; STP}$	SCL SDA	0.6	–	–	μs	
STOP to START BUS Open Time	t_{BUF}	SCL SDA	1.3	–	–	μs	

6. Design Assurance (Shipment test none).

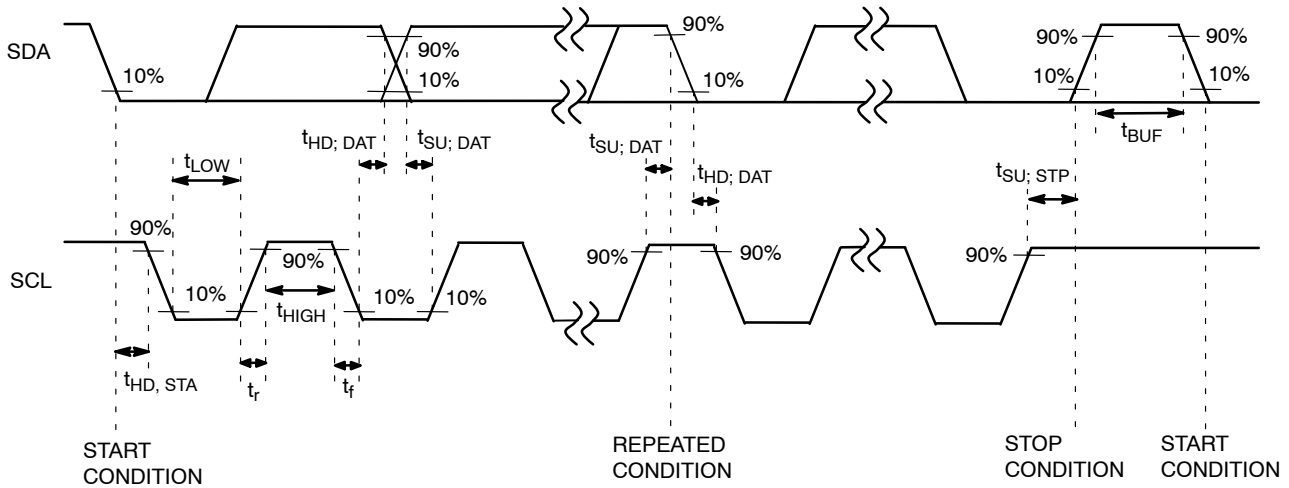

Figure 10.

AC CHARACTERISTICS (POWER ON RESET) ($V_{SS} = 0\text{ V}$, $V_{DD} = 3.0\text{ to }5.5\text{ V}$, $T_a = -30^\circ\text{C to }+85^\circ\text{C}$)

Parameter	Symbol	Min	Typ	Max	Unit	Comment
V_{DD} Rise Up Time	t_{VDDUP}	–	–	100	ms	–

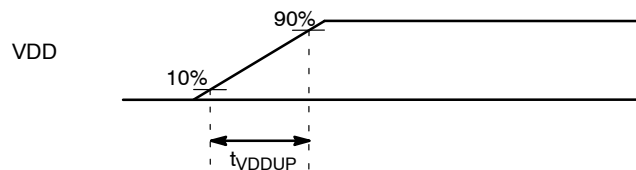

Figure 11. V_{DD} Rise Up Time Chart

LC898301XA

APPLICATION INFORMATION

A Vibration is Controlled by EN & RSTB Pin

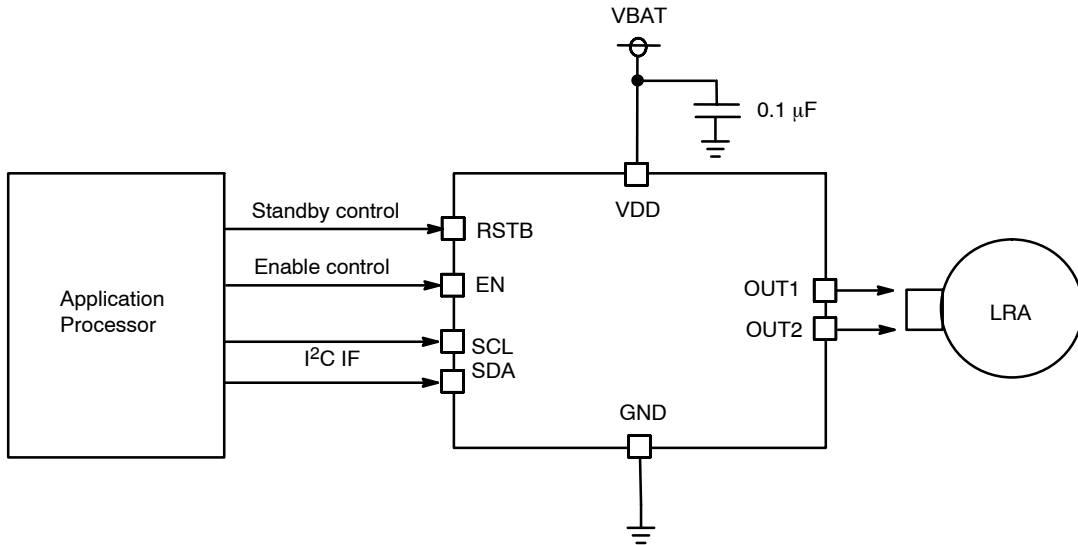

Figure 12.

A Vibration is Controlled by PWM Input RSTB Pin

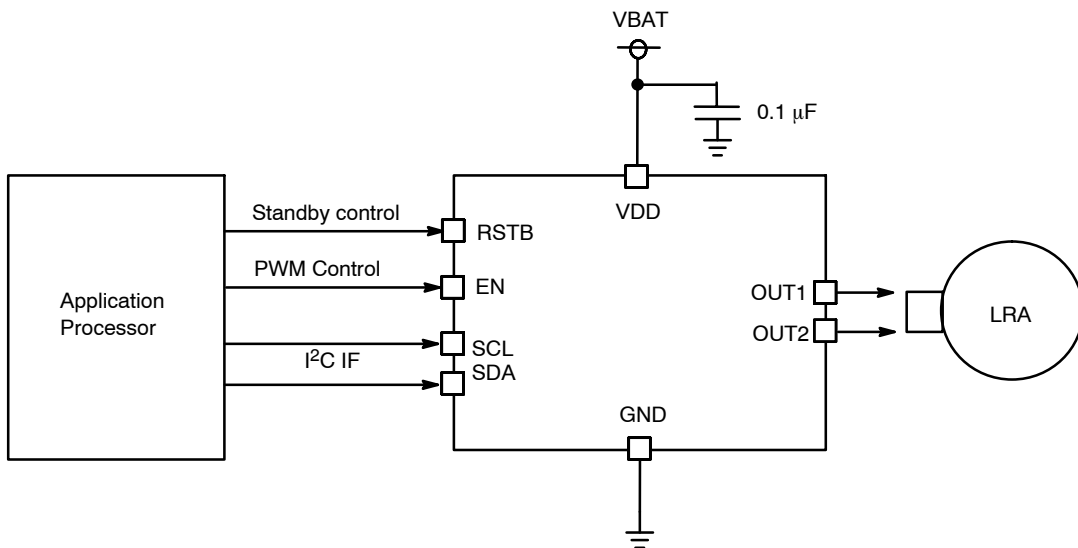

Figure 13.

LC898301XA

A Vibration is Controlled by 0 × 09 ENON Register

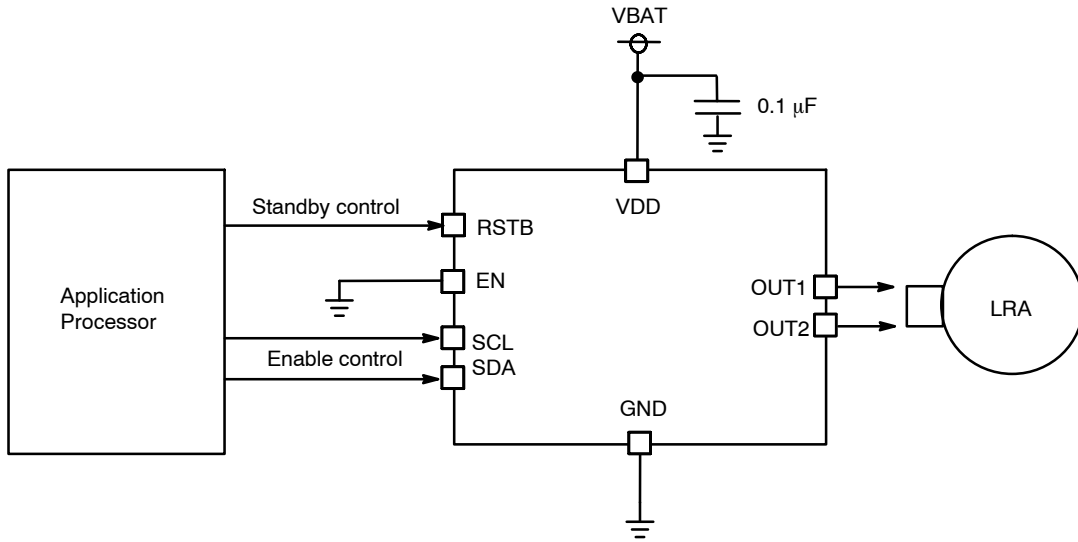

Figure 14.

A Vibration is Controlled by RSTB Pin Only

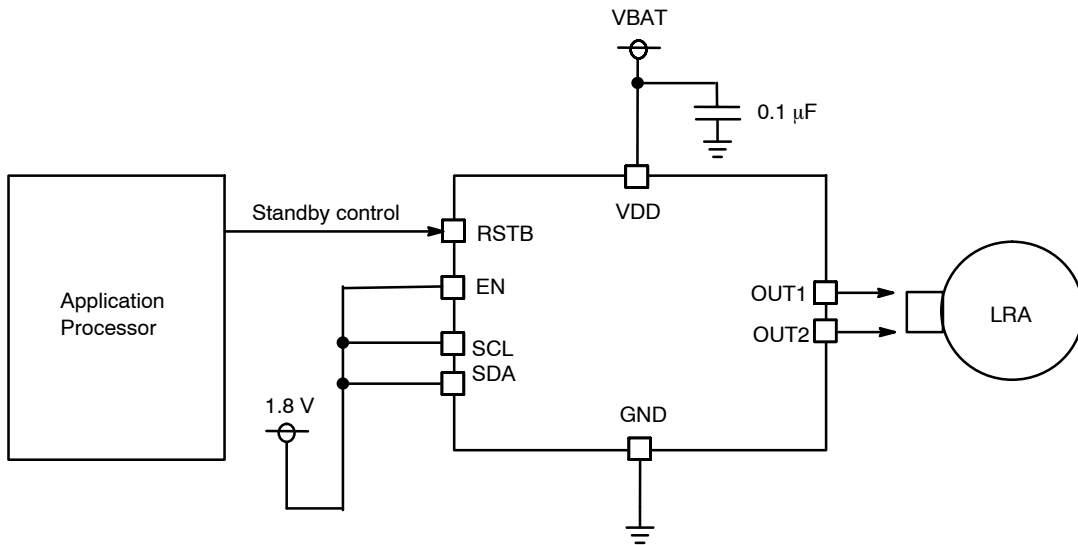

Figure 15.

LC898301XA

A Vibration is Controlled by V_{DD} Supply Only

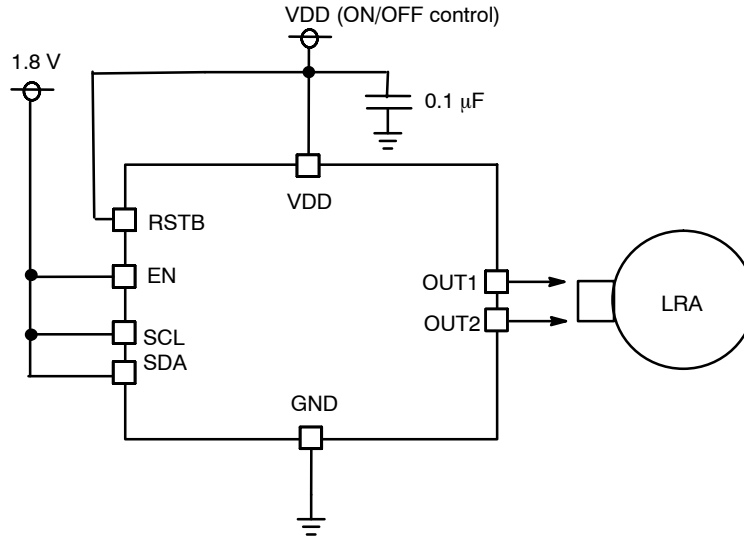

Figure 16.

MECHANICAL CASE OUTLINE

PACKAGE DIMENSIONS

ON Semiconductor®



SCALE 4:1

WLCSP8, 0.78x1.58
CASE 567HA
ISSUE O

DATE 30 APR 2013

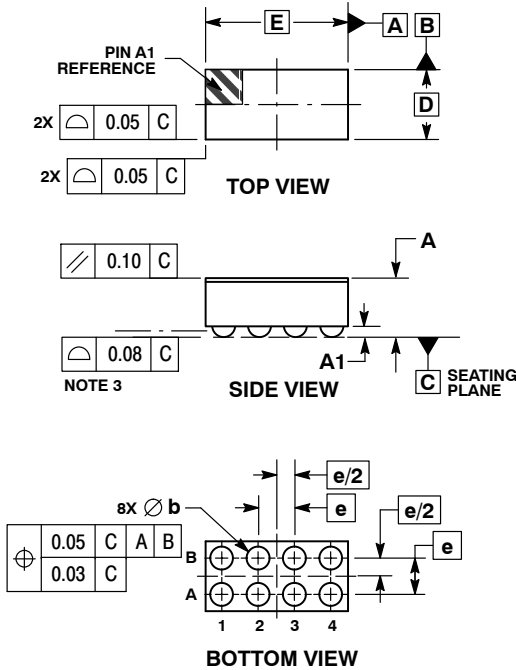

NOTES:

1. DIMENSIONING AND TOLERANCING PER ASME Y14.5M, 1994.
2. CONTROLLING DIMENSION: MILLIMETERS.
3. COPLANARITY APPLIES TO SPHERICAL CROWNS OF THE SOLDER BALLS.

DIM	MILLIMETERS	
	MIN	MAX
A	---	0.65
A1	0.07	0.17
b	0.15	0.25
D	0.78 BSC	
E	1.58 BSC	
e	0.40 BSC	

RECOMMENDED SOLDERING FOOTPRINT*

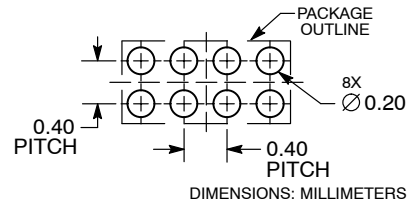

*For additional information on our Pb-Free strategy and soldering details, please download the ON Semiconductor Soldering and Mounting Techniques Reference Manual, SOLDERRM/D.

DOCUMENT NUMBER:	98AON89204E	Electronic versions are uncontrolled except when accessed directly from the Document Repository. Printed versions are uncontrolled except when stamped "CONTROLLED COPY" in red.
DESCRIPTION:	WLCSP8, 0.78X1.58	PAGE 1 OF 1

ON Semiconductor and are trademarks of Semiconductor Components Industries, LLC dba ON Semiconductor or its subsidiaries in the United States and/or other countries. ON Semiconductor reserves the right to make changes without further notice to any products herein. ON Semiconductor makes no warranty, representation or guarantee regarding the suitability of its products for any particular purpose, nor does ON Semiconductor assume any liability arising out of the application or use of any product or circuit, and specifically disclaims any and all liability, including without limitation special, consequential or incidental damages. ON Semiconductor does not convey any license under its patent rights nor the rights of others.

onsemi, **Onsemi**, and other names, marks, and brands are registered and/or common law trademarks of Semiconductor Components Industries, LLC dba "**onsemi**" or its affiliates and/or subsidiaries in the United States and/or other countries. **onsemi** owns the rights to a number of patents, trademarks, copyrights, trade secrets, and other intellectual property. A listing of **onsemi**'s product/patent coverage may be accessed at www.onsemi.com/site/pdf/Patent-Marking.pdf. **onsemi** reserves the right to make changes at any time to any products or information herein, without notice. The information herein is provided "as-is" and **onsemi** makes no warranty, representation or guarantee regarding the accuracy of the information, product features, availability, functionality, or suitability of its products for any particular purpose, nor does **onsemi** assume any liability arising out of the application or use of any product or circuit, and specifically disclaims any and all liability, including without limitation special, consequential or incidental damages. Buyer is responsible for its products and applications using **onsemi** products, including compliance with all laws, regulations and safety requirements or standards, regardless of any support or applications information provided by **onsemi**. "Typical" parameters which may be provided in **onsemi** data sheets and/or specifications can and do vary in different applications and actual performance may vary over time. All operating parameters, including "Typicals" must be validated for each customer application by customer's technical experts. **onsemi** does not convey any license under any of its intellectual property rights nor the rights of others. **onsemi** products are not designed, intended, or authorized for use as a critical component in life support systems or any FDA Class 3 medical devices or medical devices with a same or similar classification in a foreign jurisdiction or any devices intended for implantation in the human body. Should Buyer purchase or use **onsemi** products for any such unintended or unauthorized application, Buyer shall indemnify and hold **onsemi** and its officers, employees, subsidiaries, affiliates, and distributors harmless against all claims, costs, damages, and expenses, and reasonable attorney fees arising out of, directly or indirectly, any claim of personal injury or death associated with such unintended or unauthorized use, even if such claim alleges that **onsemi** was negligent regarding the design or manufacture of the part. **onsemi** is an Equal Opportunity/Affirmative Action Employer. This literature is subject to all applicable copyright laws and is not for resale in any manner.

PUBLICATION ORDERING INFORMATION

LITERATURE FULFILLMENT:

Email Requests to: orderlit@onsemi.com

onsemi Website: www.onsemi.com

TECHNICAL SUPPORT

North American Technical Support:

Voice Mail: 1 800-282-9855 Toll Free USA/Canada

Phone: 011 421 33 790 2910

Europe, Middle East and Africa Technical Support:

Phone: 00421 33 790 2910

For additional information, please contact your local Sales Representative