

150V N-Ch Power MOSFET

Feature

- ◇ High Speed Power Smooth Switching
- ◇ Enhanced Body diode dv/dt capability
- ◇ Enhanced Avalanche Ruggedness
- ◇ 100% UIS Tested, 100% Rg Tested
- ◇ Lead Free

Application

- ◇ Synchronous Rectification in SMPS
- ◇ Hard Switching and High Speed Circuit
- ◇ Power Tools
- ◇ UPS
- ◇ Motor Control

V_{DS}		150	V
$R_{DS(on),typ}$	TO-263	3.9	mΩ
$R_{DS(on),typ}$	TO-247	4.2	mΩ
$R_{DS(on),typ}$	TO-220	4.3	mΩ
I_D (Silicon Limited)		206	A

Part Number	Package	Marking
HGB043N15S	TO-263	GB043N15S
HGK043N15S	TO-247	GK043N15S
HGP043N15S	TO-220	GP043N15S

TO-263



TO-220



TO-247

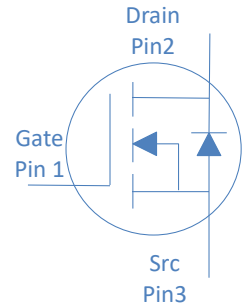

Absolute Maximum Ratings at $T_J=25^{\circ}\text{C}$ (unless otherwise specified)

Parameter	Symbol	Conditions	Value	Unit
Continuous Drain Current (Silicon Limited)	I_D	$T_C=25^{\circ}\text{C}$	206	A
		$T_C=100^{\circ}\text{C}$	146	
Drain to Source Voltage	V_{DS}	-	150	V
Gate to Source Voltage	V_{GS}	-	± 20	V
Pulsed Drain Current	I_{DM}	-	650	A
Avalanche Energy, Single Pulse	E_{AS}	$L=0.4\text{mH}, T_C=25^{\circ}\text{C}$	720	mJ
Power Dissipation	P_D	$T_C=25^{\circ}\text{C}$	429	W
Operating and Storage Temperature	T_J, T_{stg}	-	-55 to 175	$^{\circ}\text{C}$

Absolute Maximum Ratings

Parameter	Symbol	Max	Unit
Thermal Resistance Junction-Case	$R_{\theta JC}$	0.35	$^{\circ}\text{C}/\text{W}$
Thermal Resistance Junction-Ambient	$R_{\theta JA}$	60	$^{\circ}\text{C}/\text{W}$

Electrical Characteristics at T_j=25°C (unless otherwise specified)
Static Characteristics

Parameter	Symbol	Conditions	Value			Unit	
			min	typ	max		
Drain to Source Breakdown Voltage	$V_{(BR)DSS}$	$V_{GS}=0V, I_D=250\mu A$	150	-	-	V	
Gate Threshold Voltage	$V_{GS(th)}$	$V_{GS}=V_{DS}, I_D=250\mu A$	2	3	4		
Zero Gate Voltage Drain Current	I_{DSS}	$V_{GS}=0V, V_{DS}=150V, T_j=25^\circ C$	-	-	1	μA	
		$V_{GS}=0V, V_{DS}=150V, T_j=100^\circ C$	-	-	100		
Gate to Source Leakage Current	I_{GSS}	$V_{GS}=\pm 20V, V_{DS}=0V$	-	-	± 100	nA	
Drain to Source on Resistance	$R_{DS(on)}$	$V_{GS}=10V, I_D=20A$	TO-263	-	3.9	4.3	m Ω
			TO-247	-	4.2	4.5	
			TO-220	-	4.3	4.6	
Transconductance	g_{fs}	$V_{DS}=5V, I_D=20A$	-	70	-	S	
Gate Resistance	R_G	$V_{GS}=0V, V_{DS}$ Open, $f=1MHz$	-	4.0	-	Ω	

Dynamic Characteristics

Input Capacitance	C_{iss}	$V_{GS}=0V, V_{DS}=75V, f=1MHz$	-	5230	-	pF
Output Capacitance	C_{oss}		-	745	-	
Reverse Transfer Capacitance	C_{rss}		-	11.5	-	
Total Gate Charge	Q_g	$V_{DD}=75V, I_D=20A, V_{GS}=10V$	-	70	-	nC
Gate to Source Charge	Q_{gs}		-	20	-	
Gate to Drain (Miller) Charge	Q_{gd}		-	10	-	
Turn on Delay Time	$t_{d(on)}$	$V_{DD}=75V, I_D=20A, V_{GS}=10V,$ $R_G=10\Omega,$	-	19	-	ns
Rise time	t_r		-	24	-	
Turn off Delay Time	$t_{d(off)}$		-	35	-	
Fall Time	t_f		-	11	-	

Reverse Diode Characteristics

Diode Forward Voltage	V_{SD}	$V_{GS}=0V, I_F=20A$	-	0.9	-	V
Reverse Recovery Time	t_{rr}	$V_R=75V, I_F=20A, di_F/dt=100A/\mu s$	-	120	-	ns
Reverse Recovery Charge	Q_{rr}		-	270	-	nC

Fig 1. Typical Output Characteristics

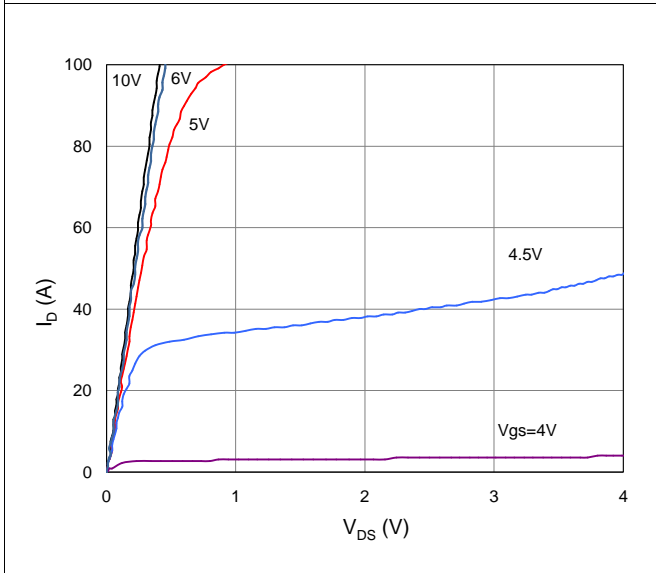

Figure 2. On-Resistance vs. Gate-Source Voltage

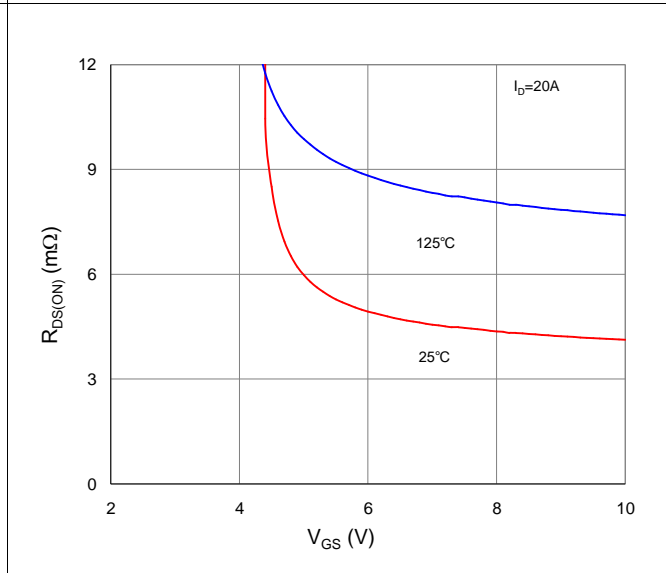

Figure 3. On-Resistance vs. Drain Current and Gate Voltage

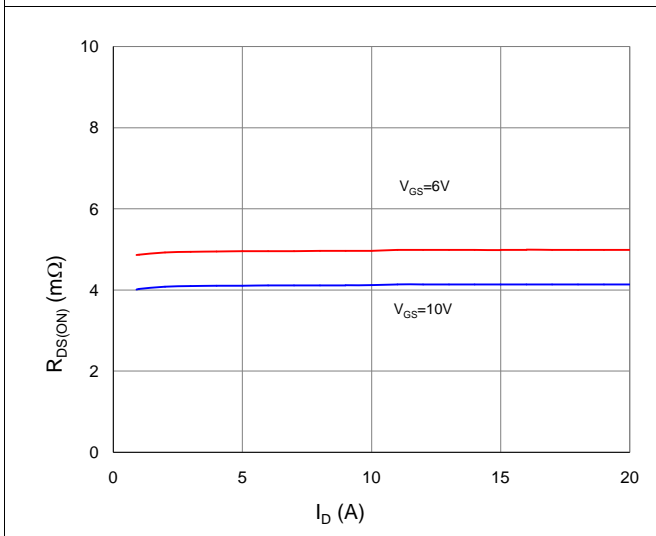

Figure 4. Normalized On-Resistance vs. Junction Temperature

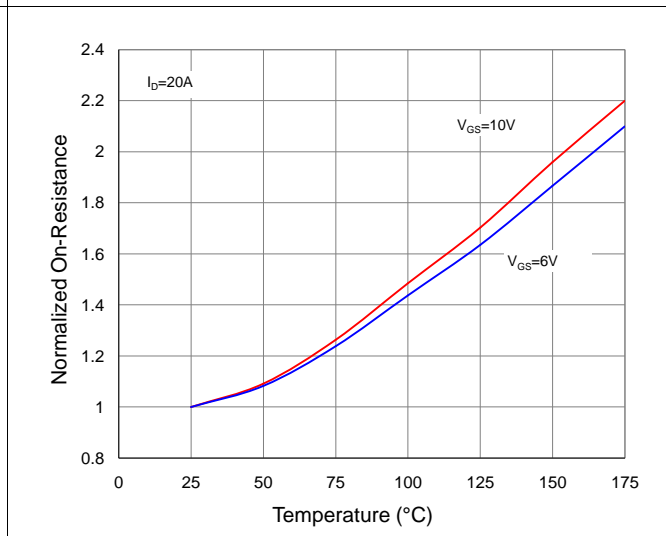

Figure 5. Typical Transfer Characteristics

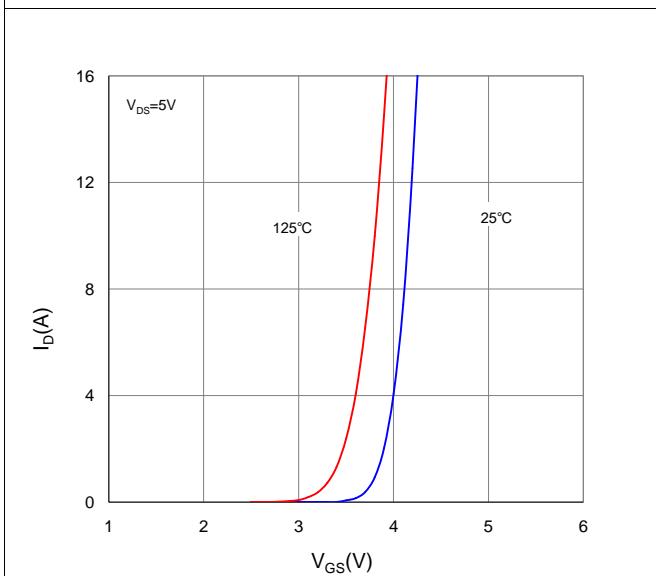

Figure 6. Typical Source-Drain Diode Forward Voltage

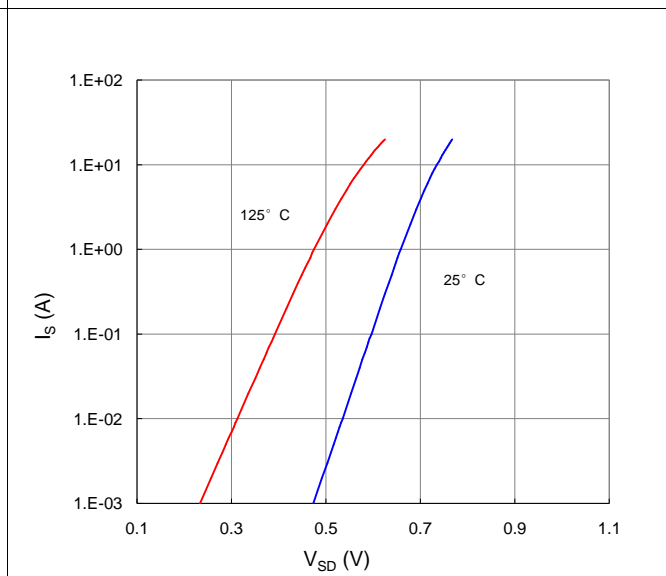

Figure 7. Typical Gate-Charge vs. Gate-to-Source Voltage

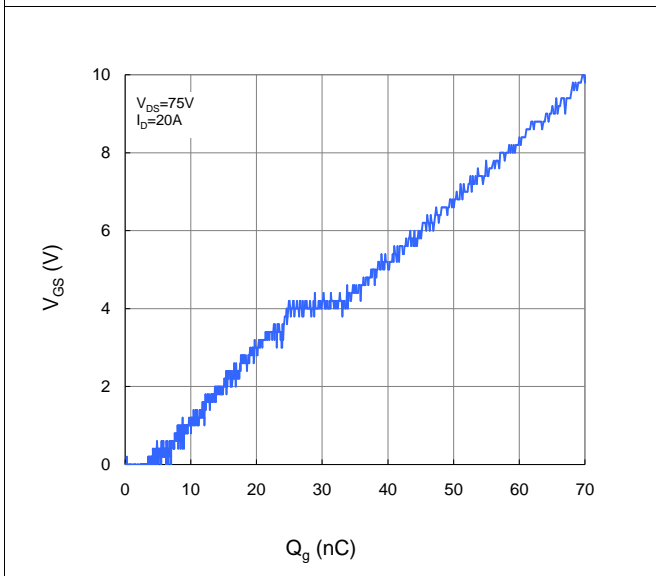

Figure 8. Typical Capacitance vs. Drain-to-Source Voltage

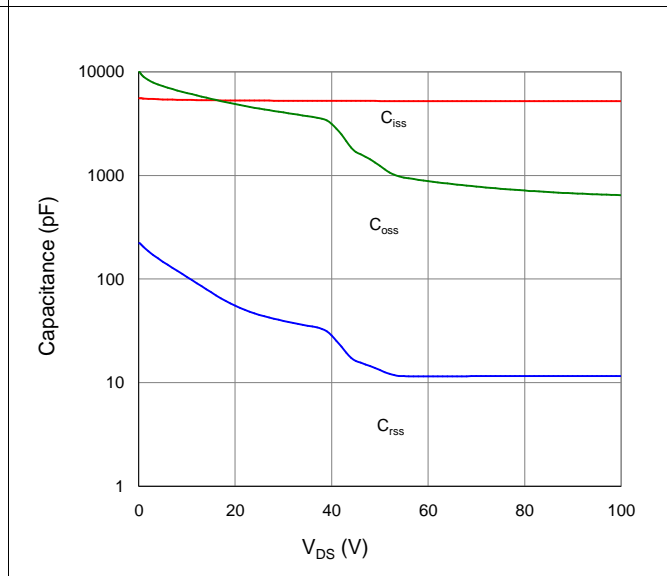

Figure 9. Maximum Safe Operating Area

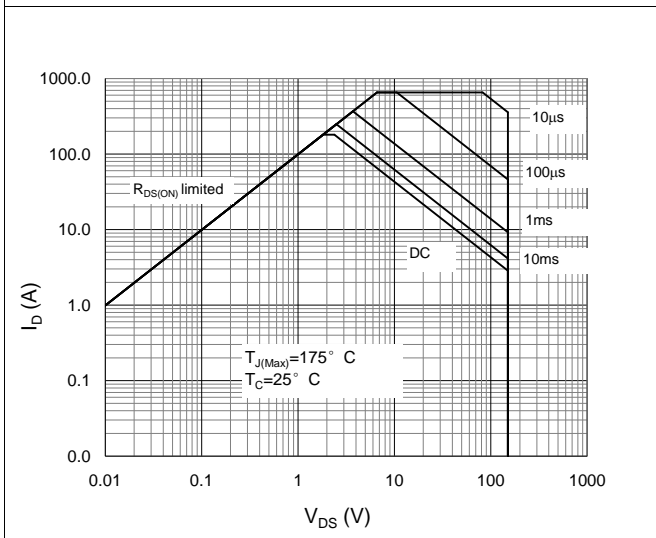

Figure 10. Maximum Drain Current vs. Case Temperature

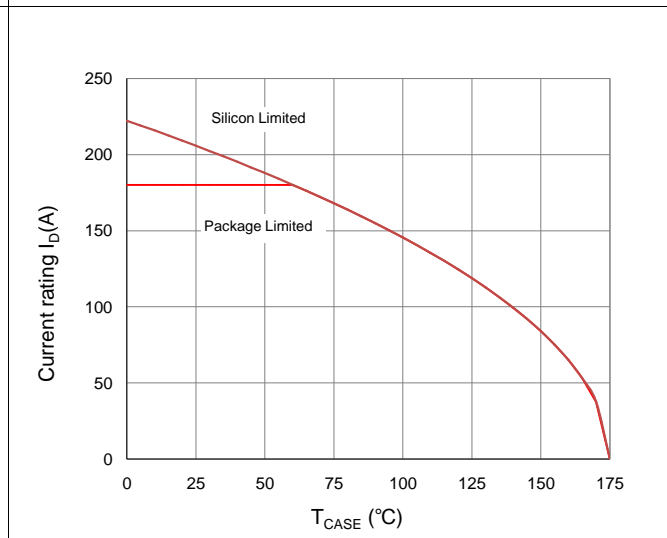
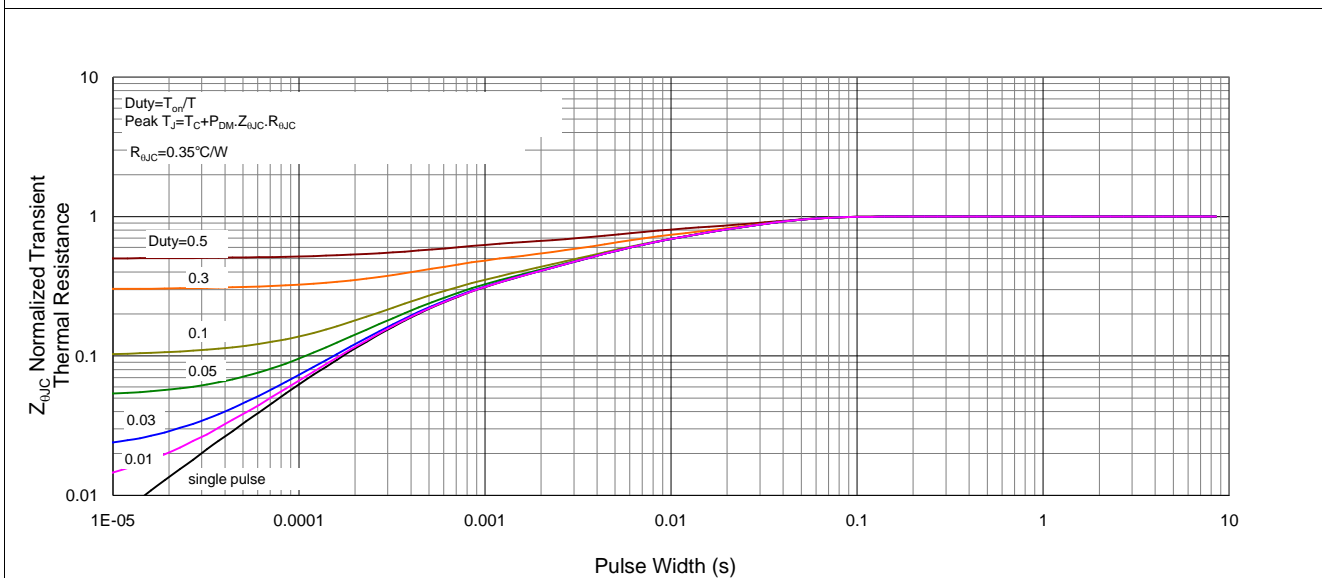
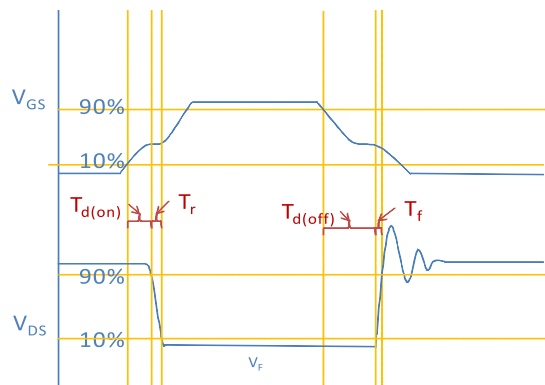
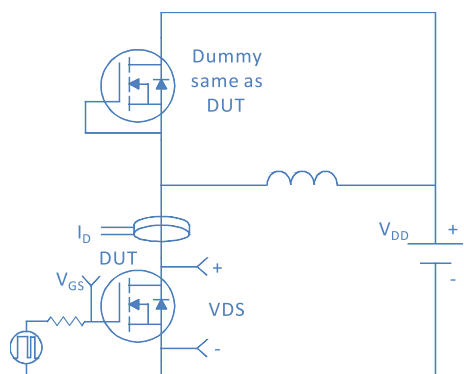

Figure 11. Normalized Maximum Transient Thermal Impedance, Junction-to-Case



Inductive switching Test



Gate Charge Test

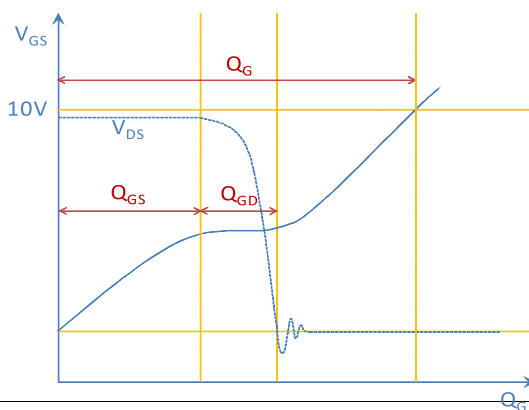
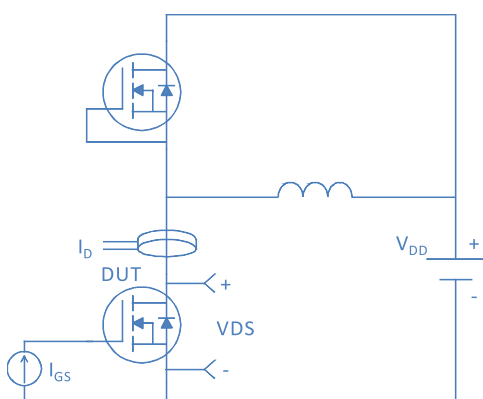

Unclamped Inductive Switching (UIS) Test

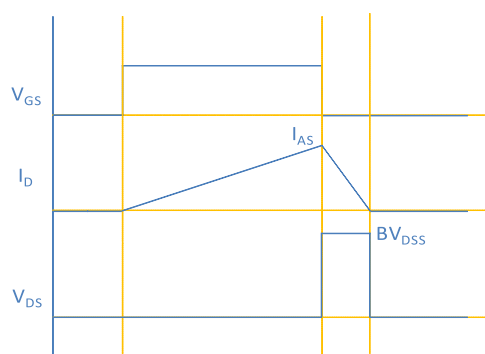
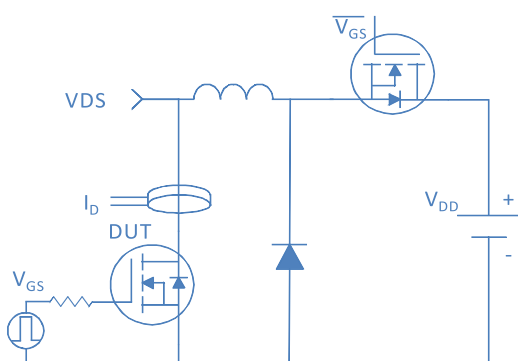

Diode Recovery Test

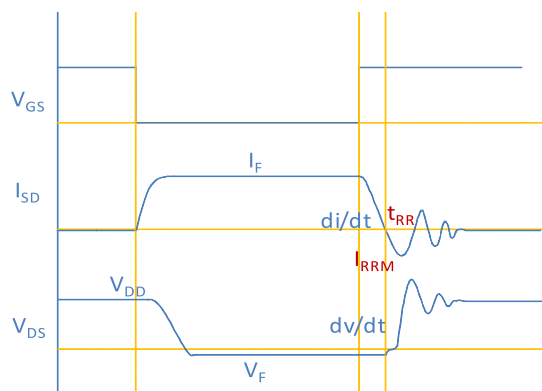
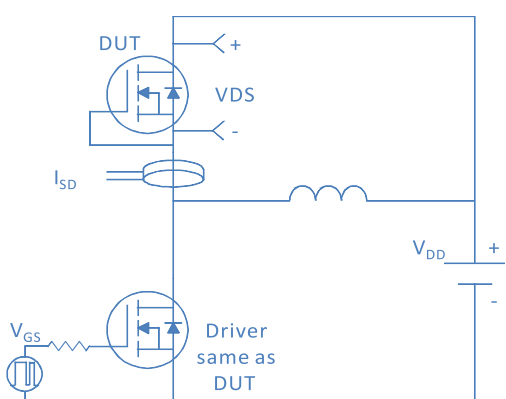

TO-220, 3 leads

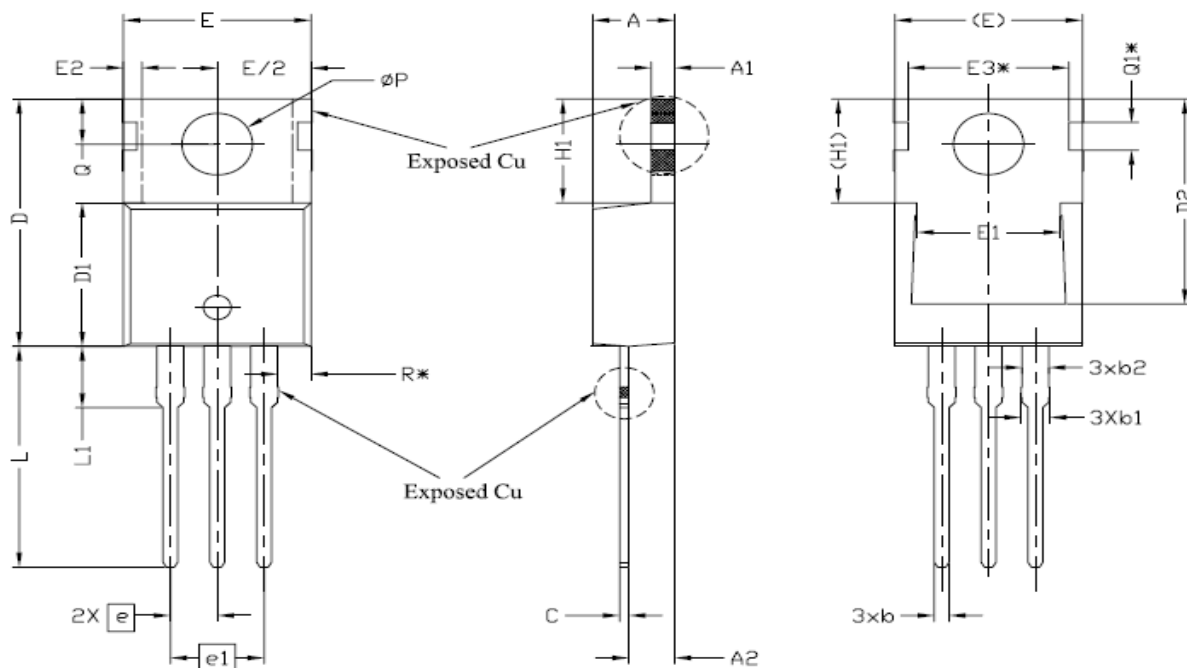

SYMBOL	DIMENSIONS			NOTES
	MIN.	NOM.	MAX.	
A	4,24	4,44	4,64	
A1	1,15	1,27	1,40	
A2	2,30	2,48	2,70	
b	0,70	0,80	0,90	
b1	1,20	1,55	1,75	
b2	1,20	1,45	1,70	
c	0,40	0,50	0,60	
D	14,70	15,37	16,00	4
D1	8,82	8,92	9,02	
D2	12,63	12,73	12,83	5
E	9,96	10,16	10,36	4,5
E1	6,86	7,77	8,89	5
E2	-	-	0,76	6
E3*	8,70REF.			
e	2,54BSC			
e1	5,08BSC			
H1	6,30	6,45	6,60	5,6
L	13,47	13,72	13,97	
L1	3,60	3,80	4,00	
ϕP	3,75	3,84	3,93	
Q	2,60	2,80	3,00	
Q1*	1,73REF.			
R*	1,82REF.			

TO-263, 2 leads

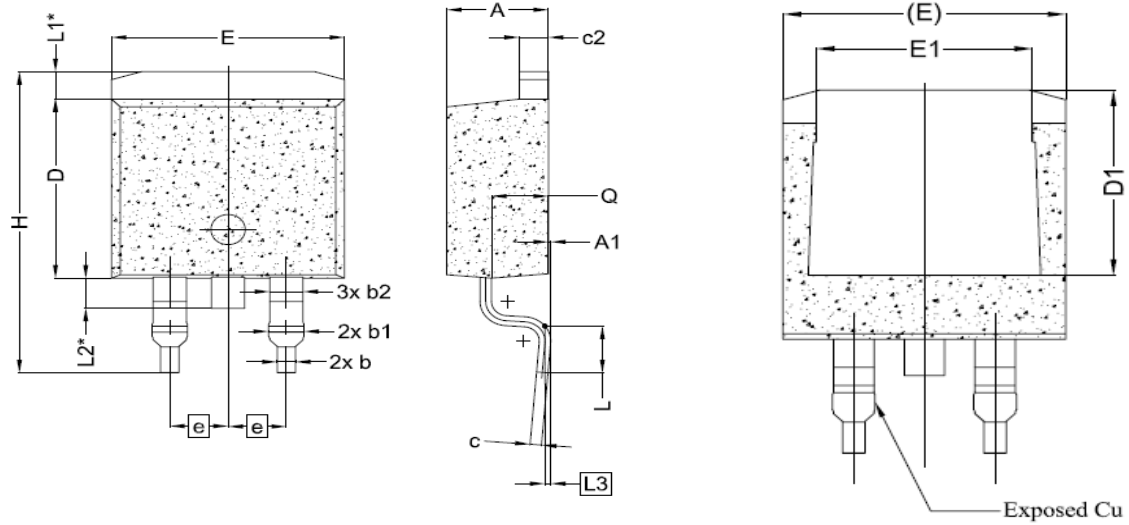

SYMBOL	DIMENSIONS		
	MIN.	NOM.	MAX.
A	4.24	4.44	4.64
A1	0.00	0.10	0.25
b	0.70	0.80	0.90
b1	1.20	1.55	1.75
b2	1.20	1.45	1.70
c	0.40	0.50	0.60
c2	1.15	1.27	1.40
D	8.82	8.92	9.02
D1	6.86	7.65	—
E	9.96	10.16	10.36
E1	6.89	7.77	7.89
e	2.54 BSC		
H	14.61	15.00	15.88
L	1.78	2.32	2.79
L1	1.36 REF.		
L2	1.50 REF.		
L3	0.25 BSC		
Q	2.30	2.48	2.70

TO-247, 3 leads

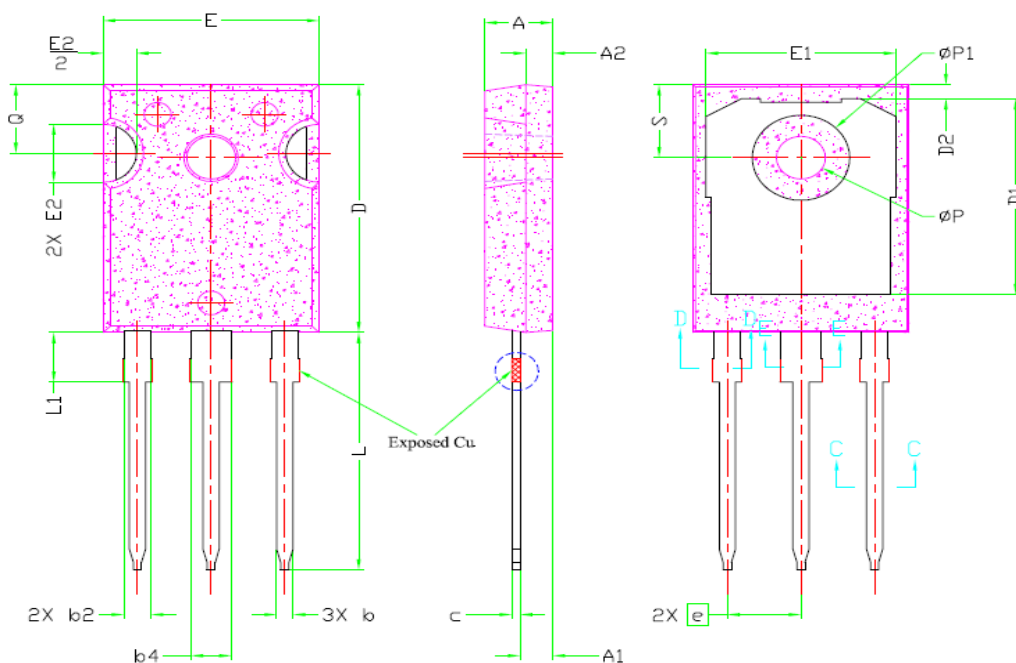

SYMBOL	DIMENSIONS			NOTES
	MIN.	NOM.	MAX.	
A	4.83	5.02	5.21	
A1	2.29	2.41	2.55	
A2	1.50	2.00	2.49	
b	1.12	1.20	1.33	
b1	1.12	1.20	1.28	
b2	1.91	2.00	2.39	6
b3	1.91	2.00	2.34	
b4	2.87	3.00	3.22	6, 8
b5	2.87	3.00	3.18	
c	0.55	0.60	0.69	6
c1	0.55	0.60	0.65	
D	20.80	20.95	21.10	4
D1	16.25	16.55	17.65	5
D2	0.51	1.19	1.35	
E	15.75	15.94	16.13	4
E1	13.46	14.02	14.16	5
E2	4.32	4.91	5.49	3
e	5.44BSC			
L	19.81	20.07	20.32	
L1	4.10	4.19	4.40	6
∅P	3.56	3.61	3.65	7
∅P1	7.19REF.			
Q	5.39	5.79	6.20	
S	6.04	6.17	6.30	