

Features

- Ultra small package: 0.6x0.3x0.3mm
- low capacitance
- Protects one data or power line
- Ultra low leakage: nA level
- Operating voltage: 3.3V
- Low clamping voltage
- 2-Pin leadless package
- Complies with following standards:
 - IEC 61000-4-2 (ESD) immunity test
Air discharge: $\pm 30\text{kV}$
Contact discharge: $\pm 30\text{kV}$
 - IEC61000-4-4 (EFT) 40A (5/50ns)
 - IEC61000-4-5 (Lightning) 16A (8/20 μs)
- RoHS Compliant

Applications

- Cellular Handsets and Accessories
- Personal Digital Assistants
- Notebooks and Handhelds
- Portable Instrumentation
- Digital Cameras
- Peripherals
- Audio Players
- Keypads, Side Keys, USB 2.0, LCD Displays

Mechanical Characteristics

- Package: DFN0603-2 (0.6x0.3x0.3mm)
- Case Material: “Green” Molding Compound.
- Moisture Sensitivity: Level 3 per J-STD-020
- Terminal Connections: See Diagram Below
- Marking Information: See Below

Absolute Maximum Ratings (T_{amb}=25°C unless otherwise specified)

Parameter	Symbol	Value	Unit
Peak Pulse Power (8/20 μs)	P _{pp}	168	W
ESD per IEC 61000-4-2 (Air)	V _{ESD}	± 30	Kv
ESD per IEC 61000-4-2 (Contact)		± 30	
Operating Temperature Range	T _J	-55 to +125	°C
Storage Temperature Range	T _{STJ}	-55 to +150	°C

Dimensions DFN0603

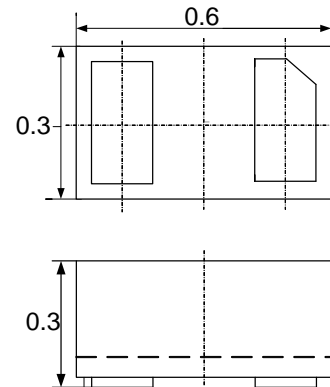

Pin Configuration

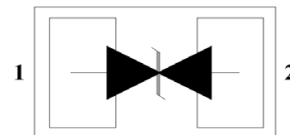

Electrical Characteristics (TA=25°C unless otherwise specified)

Part Number	Device Marking	V _{RWM} (V)	V _{BR} (V)	I _T (mA)	V _C @1A	V _C		I _R μA (Max)	C (Pf) (Typ.)
						(Max)	(@A)		
ESD3321CH	E	3.3	3.8	1	-	10.5	16	0.1	15

Typical Performance Characteristics (TA=25°C unless otherwise Specified)

Figure 1. 8 x 20 μs Waveform

Figure 2. Power Derating Curve

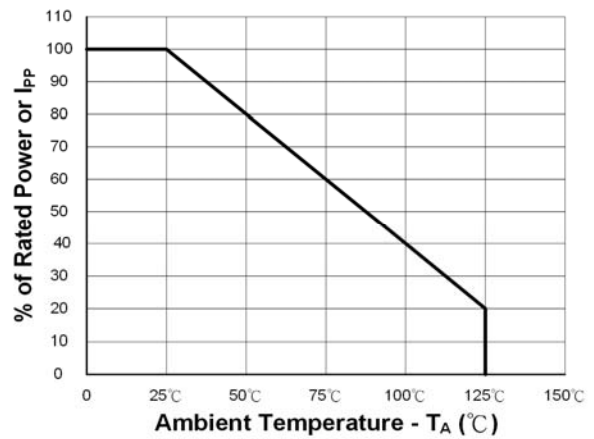
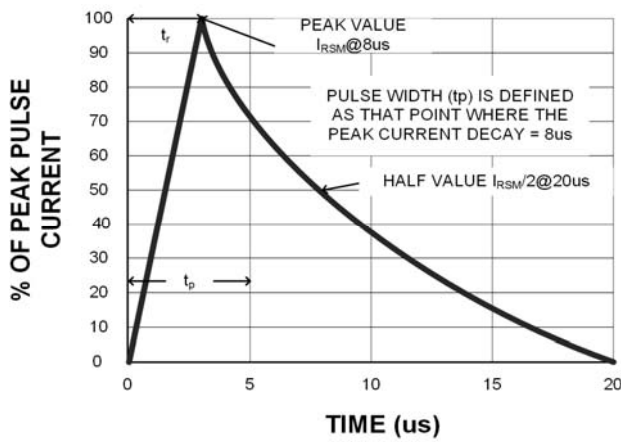

Figure 3. Clamping Voltage vs. Peak Pulse Current ($t_p=8/20 \mu s$)

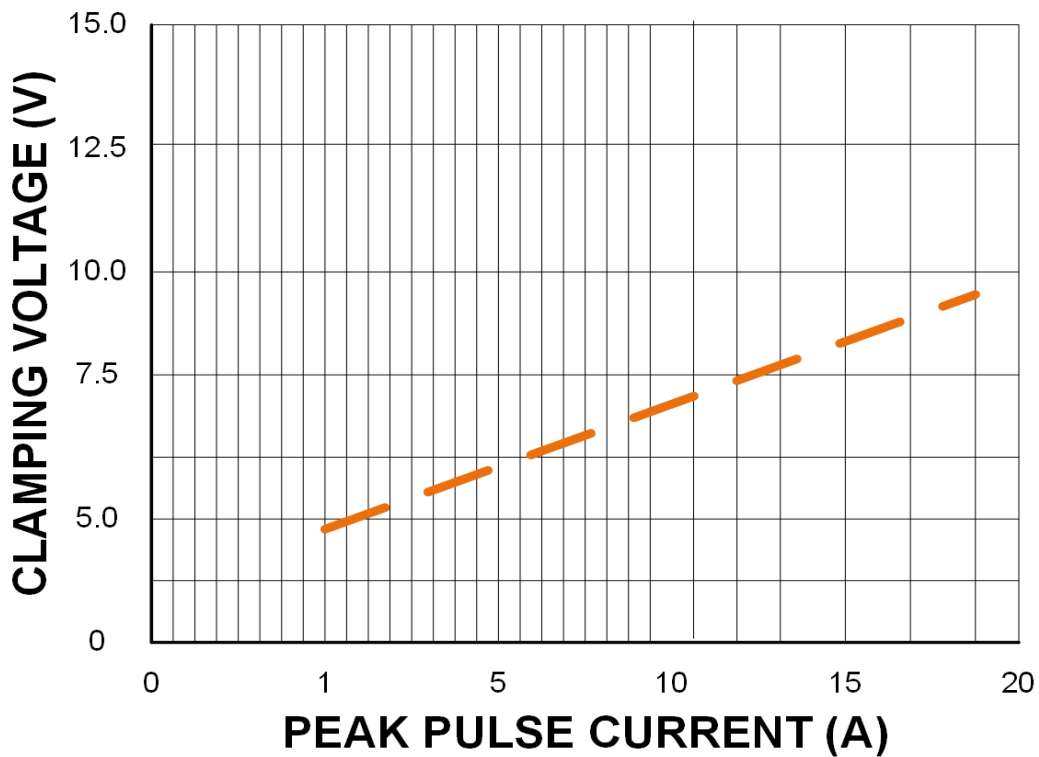

Figure 4. Typic Breakdown Voltage vs. Temperature

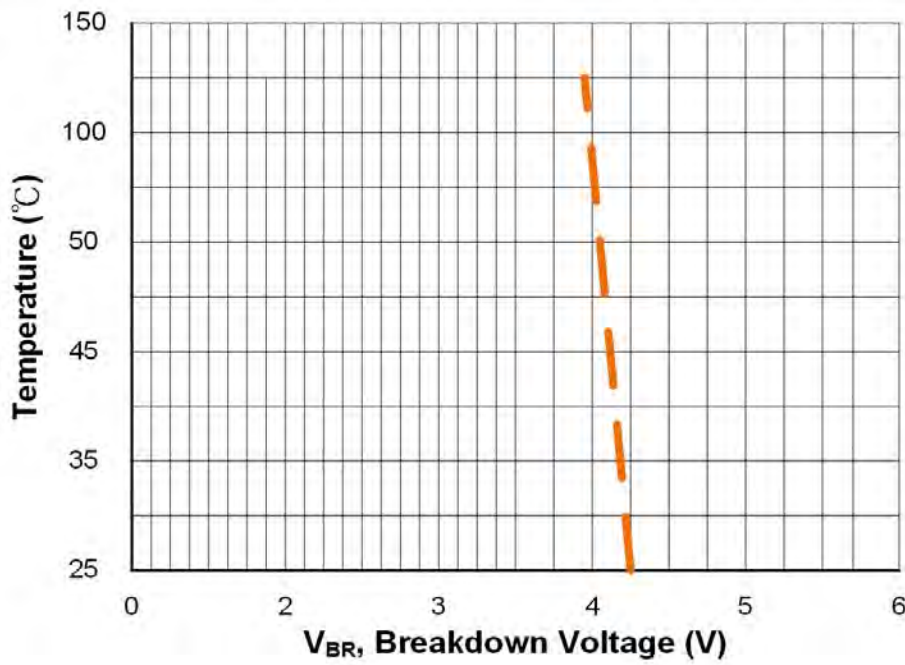

Figure 5. Typic Reverse Current vs. Temperature

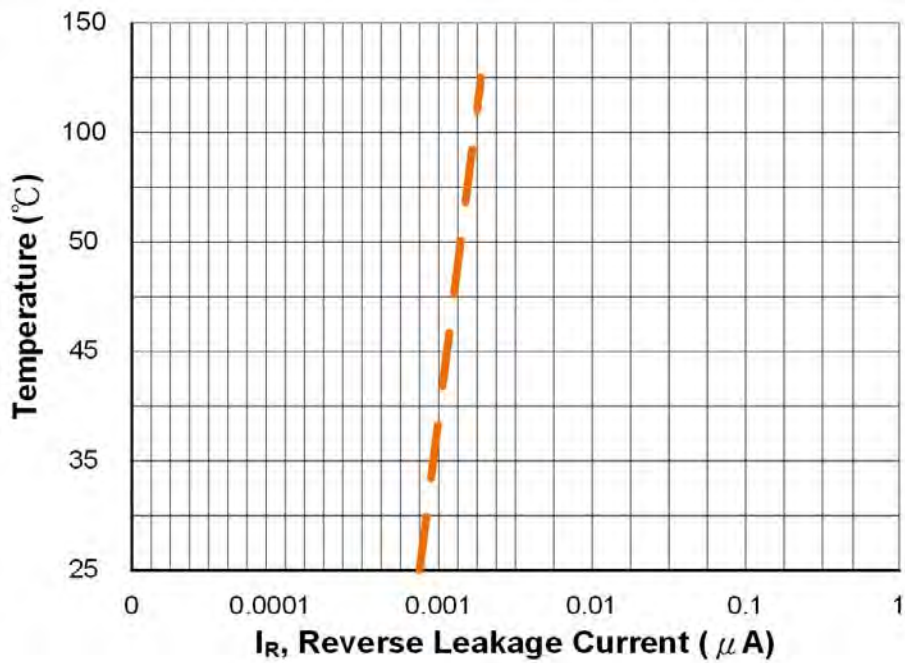

Figure 6. Typic Capacitance vs. Reverse Voltage

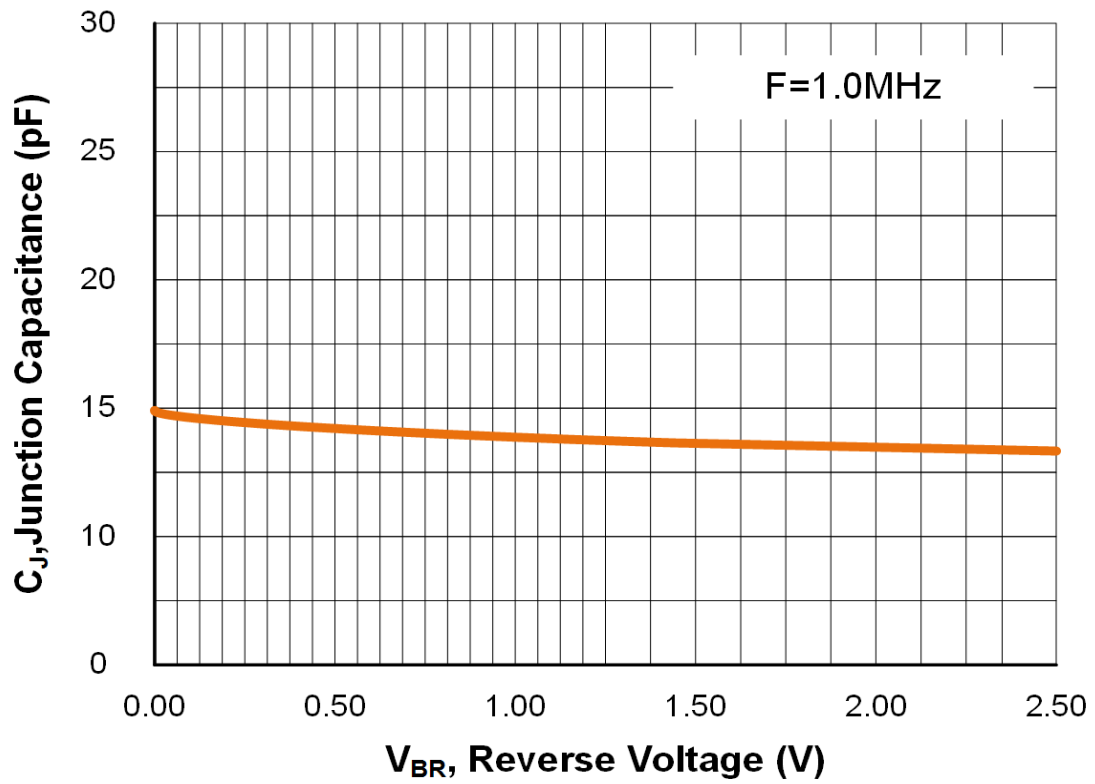
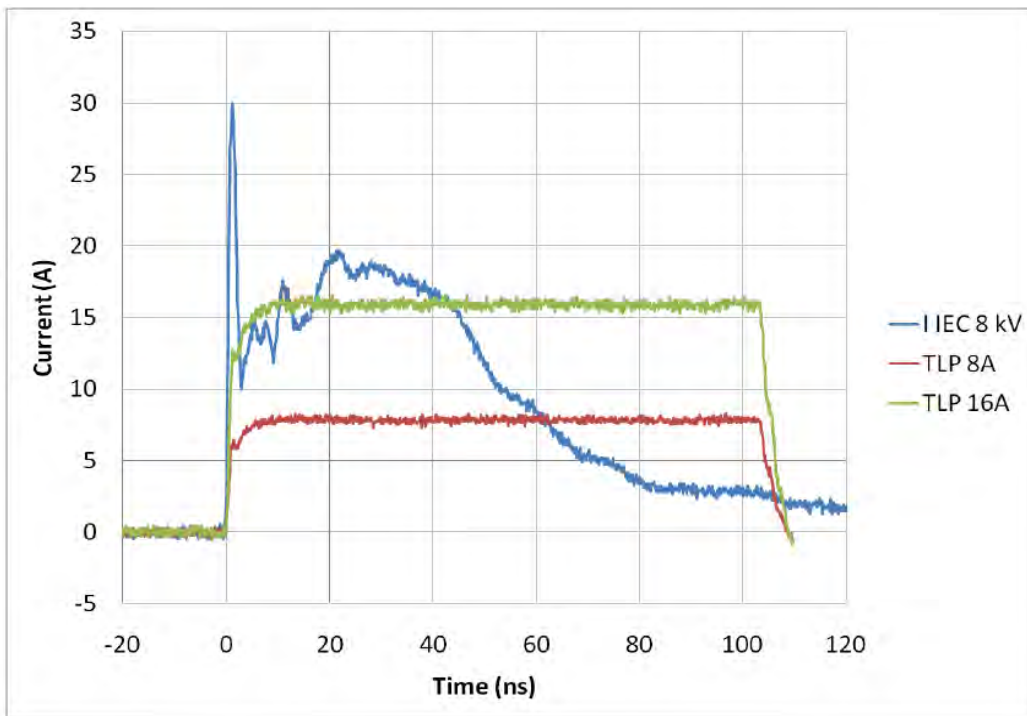

Figure 7. Transmission Line Pulse (TLP)

Transmission Line Pulse (TLP) is a measurement technique used in the Electrostatic Discharge (ESD) arena to characterize performance attributes of devices under ESD stresses. TLP is able to obtain current versus voltage (I–V) curves in which each data point is obtained with a 100 ns long pulse, with currents up to 40 A. TLP was first used in the ESD field to study human body model (HBM) in integrated circuits, but it is an equally valid tool in the field of system level ESD. The applicability of TLP to system level ESD is illustrated in Figure 1, which compares an 8 kV IEC 61000–4–2 current waveform with TLP current pulses of 8 and 16 A. The current levels and time duration for the pulses are similar and the initial rise time for the TLP pulse is comparable to the rise time of the IEC 61000–4–2’s initial current spike. This application note will give a basic introduction to TLP measurements and explain the datasheet parameters extracted from TLP for SDI Technology’s protection products.



Comparison Between 8 kV IEC 61000–4–2 and 8 A and 16 A TLP Waveforms

Comparison of a CurrentWaveform of IEC 61000–4–2with TLP Pulses at 8 and 16 A.

The IEC 61000–4–2 ESD waveforms is true to the Standard and is shown here as captured on an oscilloscope.

The points A, B, and C show the points on the aveforms specified in IEC 61000–4–2.

Transmission Line Pulse (TLP) Version.

DFN0603 Package Outline Drawing

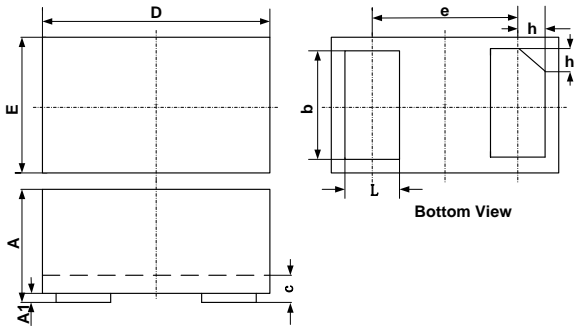

SYM	DIMENSIONS		
	MILLIMETERS		
	MIN	NOM	MAX
A	0.230		0.330
A1	0.000	0.020	0.050
b	0.215	0.245	0.275
c	0.120	0.150	0.180
D	0.550	0.600	0.650
e	0.355 BSC		
E	0.250	0.300	0.350
L	0.160	0.190	0.220
h	0.079 BSC		

Suggested Land Pattern

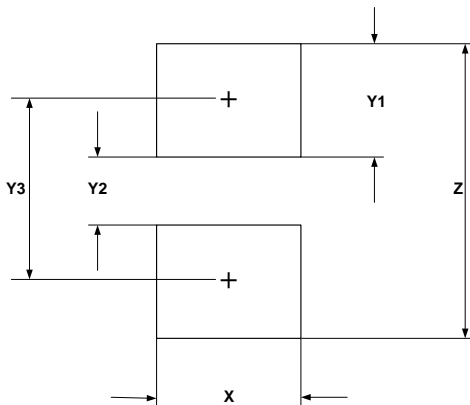

SYM	DIMENSIONS	
	MILLIMETERS	INCHES
X	0.30	0.012
Y1	0.25	0.010
Y2	0.15	0.006
Y3	0.40	0.016
Z	0.65	0.026