

REV.	DESCRIPTION OF REVISIONS	APPR.	DRAW.	RELEASE	DATE

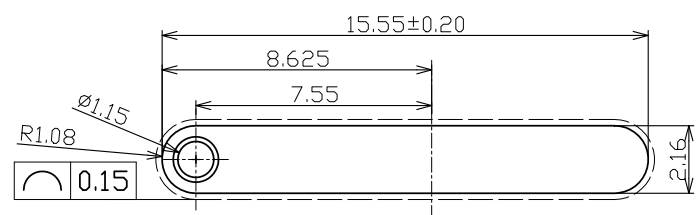
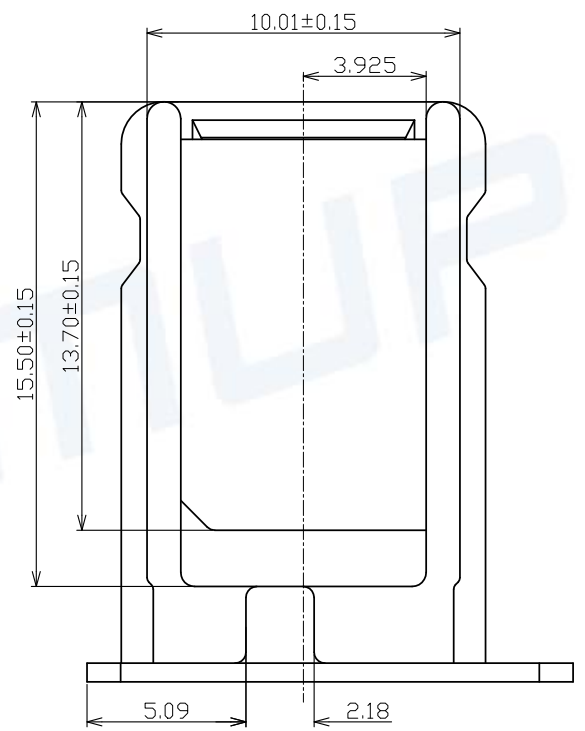
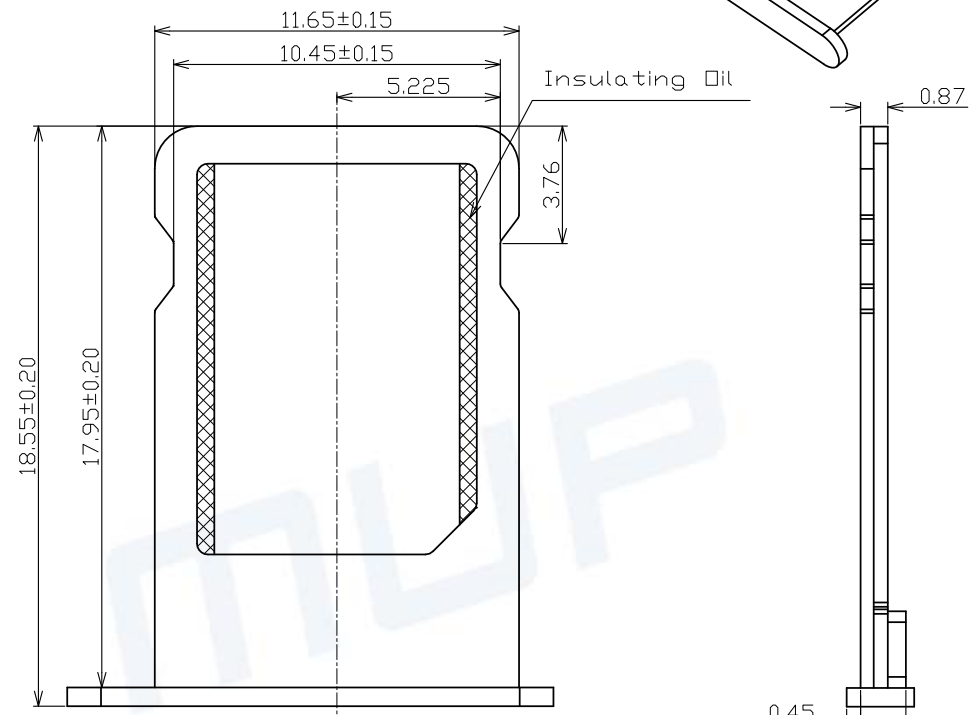
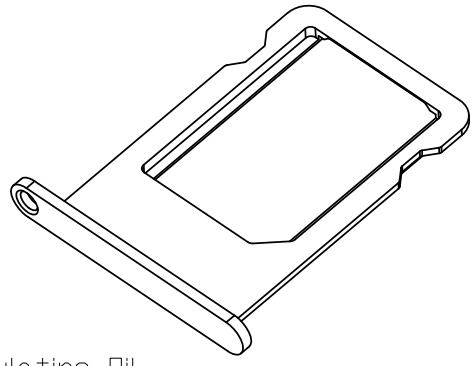

No.	Part Name	Colour
1	C7804-31A	Black
2	C7804-32A	Silvery white

ITEM	PART NAME	Q'TY	MATERIAL	FINISH
1	METAL BODY	1	STAINLESS STEEL	PVD/Electrophoresis
2		1		

Unless otherwise specified, other tolerance are:

MUP MUP INDUSTRIAL CO.,LTD.

X ±0.35	X* ±5*	NAME:	SIM CARD TRAY	
X.X ±0.25	X.X* ±4*	MODEL NO.:	MUP-C7804-31A&32A	
X.XX ±0.15	X.XX* ±3*	TYPE :	With Cap of the card tray	
X.XXX ±0.10	X.XXX* ±2*	PROJ.	UNIT	SCALE
PROJ.	UNIT	mm	1:1	DRAWN
CUSTOMER DRAWING	CHECKED	APPROVAL	DWG NO.:	DWG-MUP-C7804-31A
			SHEET	REVISION
			1/1	X1

NOTE:
 1.Powder Metallurgy Material: Stainless Steel (e.g. 17-4PH F)
 2.Finish: PVD/Electrophoresis
 3.Appearance is not Acceptable: Corrosion,Poor Coating ,Scratches, Warping Sharp Edges(saw burrs),Bumps,Poor Plating, Stains
 4.Surface needs to be Done to Deal with Passivation
 5.Unless Otherwise 0.10mm Round;
 6.Please Contact PROMAX Sales Representative to Verify Product Details.

