

WITH CAP

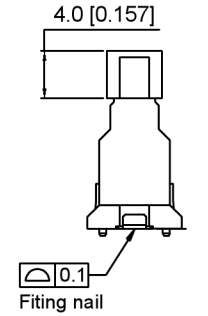

WITH CAP

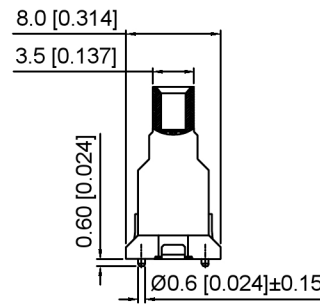
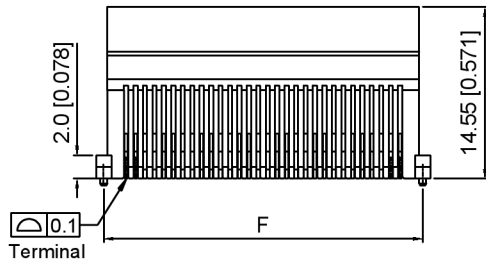
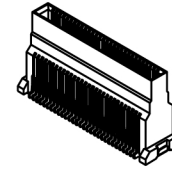
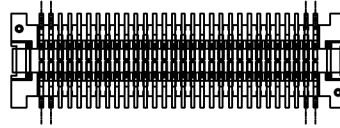
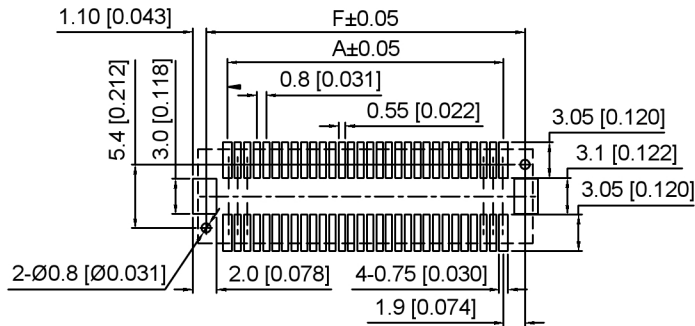

Recommended PCB Layout

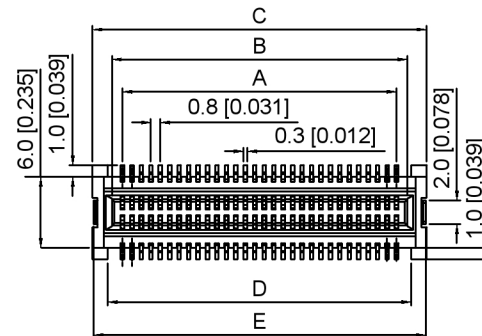

Specifications:

规格:

Voltage rating: 50V AC/DC

额定电压: 50V AC/DC

Current rating: 0.5A AC/DC

额定电流: 0.5A AC/DC

Withstanding voltage: 250V AC/minute

耐受电压: 250V AC/分钟

Temperature range: -40°C-+105°C

温度范围: -40°C-+105°C

Insulation resistance: 500MΩ

绝缘电阻: 500MΩ

Contact resistance: 100mΩ

接触电阻: 100mΩ

X0815 W V S-XX F S-9T V01

① ② ③ ④ ⑤ ⑥ ⑦ ⑧ ⑨

1. Series No
2. Category: W-Wafer
3. Welding Board Angle: V-Stright 180°
4. Welding Way: S-SMT
5. Row No. Pin No: XX-30-60Pin
6. Category: F-14.55mm Height
7. Special No: S-With positioning column
8. Material: 9T-PA9T UL94V-0
CAP Material: PA6T UL94V-0
9. Plating: Gold Plated 3u" MIN

Poles	Dimensions(mm)					
	A	B	C	D	E	F
30	11.20	13.00	16.30	13.70	16.10	15.00
40	15.20	17.00	20.30	17.70	20.10	19.00
50	19.20	21.00	24.30	21.70	24.10	23.00
60	23.20	25.00	28.30	25.70	28.10	27.00

X0815WVS-XXFS-9TV01	PA9T	Phosphor Bronze	X0815FVS-A	19.5mm±0.5
			X0815FVS-B	15.75mm±0.5
PART NO	Material	Material(Pin)	Suitable XKB Wafer	Mating Height

DSND		SCALE: N/A	MODEL TYPE: 0.8mm BTB Connector		
DWN		VIEW:	PART NO.: X0815WVS-XXFS-9TV01		
CHKD		UNIT: mm/in	DWG NO.:		
APPD		SIZE: A4	X-X0815WVS-XXFS-9TV01		
			WEIGHT	SHEET	REVISION
				1/1	A0



XKB INDUSTRIAL PRECISION CO., LIMITED

广东星坤科技股份有限公司

ΔX		日期
ΔX		日期
ΔX		日期

文件工程章

MARK	DESCRIPTION	DATE	REVISED	APPROVED	REVISIONS
					UNSPECIFIED TOLERANCES

www.helloxkb.com www.helloxkb.cn www.xk-dg.cn