

Features

- Low power consumption
- Low voltage drop
- Low temperature coefficient
- Low Quiescent Current: 5uA at 6V
- Output voltage accuracy: tolerance $\pm 2\%$

Applications

- Battery-powered equipment
- Reference voltage sources
- Cameras, video cameras
- Portable AV systems
- Mobile phones
- Portable games

General Description

HE6206 series are a highly precise, lower consumption, 3 terminal, positive voltage regulators manufactured using CMOS and laser trimming technologies. The series provides large currents with a significantly small dropout voltage .

The HE6206 consists of a current limiter circuit, a driver transistor, a precision reference voltage and an error correction circuit. The series is compatible with low ESR ceramic capacitors. The

current limiter's foldback circuit operates as a short circuit protection as well as the output current limiter for the output pin. Output voltages are internally by laser trimming technologies. It is selectable in 0.1V increments within a range of 1.2V to 5.0V. HE6206 series are available in SOT-23 、 SOT23-3and SOT-89 packages.

Typical Application

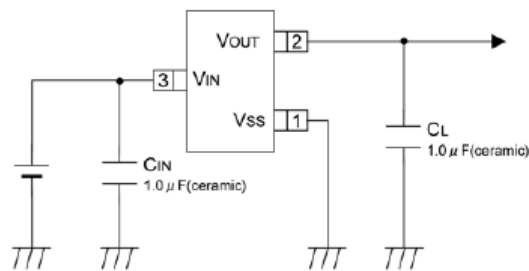

Order Information

HE6206- ①②③④

Environmental Standard:
R:RoHs/Pb Free
G: Halogen Free

Package:
N:SOT23
M:SOT23-3
P:SOT89

Output Voltage:
15-50: e.g. 15=1.5V 30=3.0V
33=3.3V 50=5.0V

Block Diagram

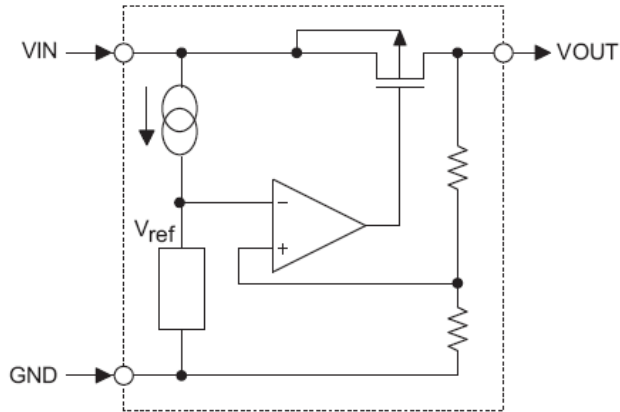

Pin Assignment

SOT23-3 and SOT23
(Top view)

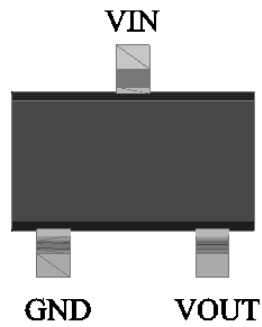

SOT89 (Top view)

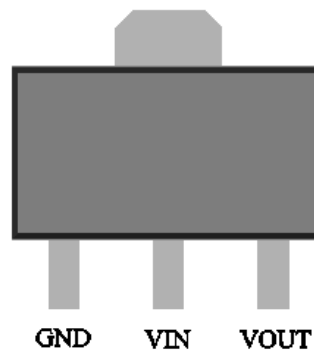

Marking Rule

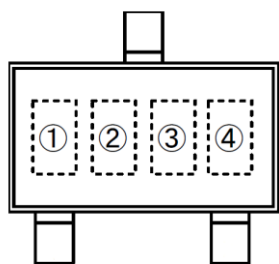

SOT-23
(TOP VIEW)

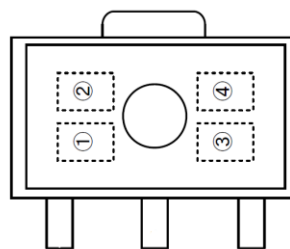

SOT-89
(TOP VIEW)

① represents product number

| | |
|------|----------------|
| MARK | PRODUCT SERIES |
| 6 | HE6206**** |

② represents 3 pins regulator

| MARK | | PRODUCT SERIES |
|------------------|-------------------|----------------|
| VOLTAGE=0.1~3.0V | VOLTAGE=3.1V~6.0V | |
| 5 | 6 | HE6206 |

③ represents output voltage

| MARK | VOLTAGE(V) | | | MARK | VOLTAGE(V) | | |
|------|------------|-----|---|------|------------|-----|---|
| 0 | - | 3.1 | - | F | 1.6 | 4.6 | - |
| 1 | - | 3.2 | - | H | 1.7 | 4.7 | - |
| 2 | - | 3.3 | - | K | 1.8 | 4.8 | - |
| 3 | - | 3.4 | - | L | 1.9 | 4.9 | - |
| 4 | - | 3.5 | - | M | 2.0 | 5.0 | - |
| 5 | - | 3.6 | - | N | 2.1 | - | - |
| 6 | - | 3.7 | - | P | 2.2 | - | - |
| 7 | - | 3.8 | - | R | 2.3 | - | - |
| 8 | - | 3.9 | - | S | 2.4 | - | - |
| 9 | - | 4.0 | - | T | 2.5 | - | - |
| A | - | 4.1 | - | U | 2.6 | - | - |
| B | 1.2 | 4.2 | - | V | 2.7 | - | - |
| C | 1.3 | 4.3 | - | X | 2.8 | - | - |
| D | 1.4 | 4.4 | - | Y | 2.9 | - | - |
| E | 1.5 | 4.5 | - | Z | 3.0 | - | - |

④ X

Absolute Maximum Ratings

| Parameter | | Symbol | Ratings | Units |
|-----------------------------|--------|-----------|-----------------------------|-------|
| Input Voltage | | V_{IN} | 8 | V |
| Output Current | | I_{OUT} | 300* | mA |
| Output Voltage | | V_{OUT} | $V_{SS}-0.3\sim V_{IN}+0.3$ | V |
| Power Dissipation | SOT-23 | P_d | 0.20 | W |
| | SOT-89 | | 0.50 | W |
| | USP-6B | | 0.10 | W |
| | TO-92 | | 0.30 | W |
| Operating Temperature Range | | T_{opr} | -40~+85 | °C |
| Storage Temperature Range | | T_{stg} | -55~+125 | °C |

* $I_{OUT}=P_d/(V_{IN}-V_{OUT})$

Electrical Characteristics

HE6206 for any output voltage

($T_a=25^\circ\text{C}$)

| Parameter | Symbol | Conditions | Min. | Typ. | Max. | Unit |
|---|-------------------------------------|--|----------------------|-----------|----------------------|------------------|
| Output Voltage | V_{out} | $V_{in}=V_{out}+1V$ $1.0mA\leq I_{out}\leq 30mA$ | $V_{out}\times 0.98$ | -- | $V_{out}\times 1.02$ | V |
| Output Current*1 | I_{out} | $V_{in}-V_{out}=1V$ | -- | 300 | -- | mA |
| Low dropout*2 | V_{drop} | Refer to the next table | | | | |
| Line Regulation | $\Delta V_{out1}/(V_{in}-V_{out})$ | $1.6V\leq V_{in}\leq 8V$ $I_{out}=40mA$ | -- | 0.05 | 0.2 | %/V |
| Load Regulation | $\Delta V_{out} / \Delta I_{out}$ | $V_{in}=V_{out}+1V$ $1.0mA\leq I_{out}\leq 80mA$ | -- | 12 | 30 | mV |
| Output voltage Temperature Coefficiency | $\Delta V_{out}/(T_a\cdot V_{out})$ | $I_{out}=30mA$ $0^\circ\text{C}\leq T_a\leq 70^\circ\text{C}$ | -- | ± 100 | -- | Ppm/°C |
| Supply Current | I_{ss1} | -- | -- | 5 | 6 | μA |
| | I_{ss2} | SOT23-5(Pull down resistor inside) | -- | 8 | 10 | μA |
| Input Voltage | V_{in} | -- | -- | -- | 8 | V |
| PSRR | PSRR | $F=1KHz$ $V_{in}=V_{out}+1V$ | -- | 50 | -- | dB |
| Output Noise | EN | $BW=10Hz\sim 100KHz$ | -- | 30 | -- | μVrms |

Electrical Characteristics by Output Voltage:

| Output Voltage $V_{out}(V)$ | Dropout Voltage V_{dif} (V) | | |
|-----------------------------|-------------------------------|------|------|
| | Conditions | Typ. | Max. |
| $V_{out} \leq 1.5V$ | $I_{out} = 100\text{ mA}$ | 0.35 | 0.57 |
| $1.8 \leq V_{out} \leq 2$ | | 0.28 | 0.42 |
| $2.8 \leq V_{out} \leq 5.0$ | | 0.19 | 0.35 |

Typical Performance Characteristics

(1) Output Voltage vs Input voltage and Output Voltage vs. Output Current and Input Transient Response

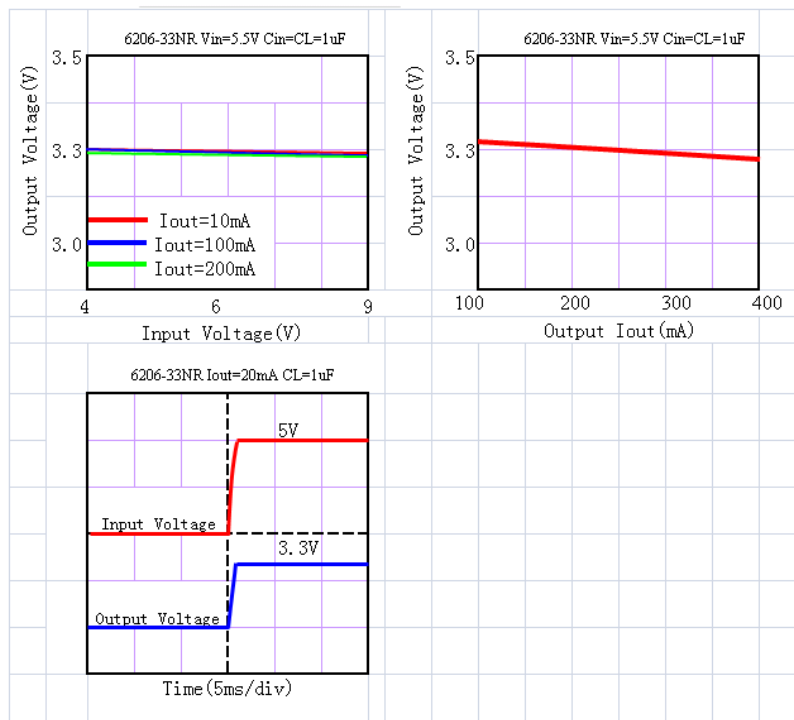

(2) Output Voltage vs. Ambient Temperature

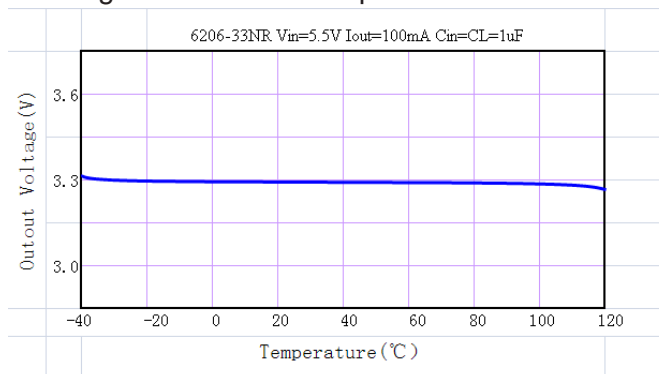

Package Information
3-pin SOT23 Outline Dimensions

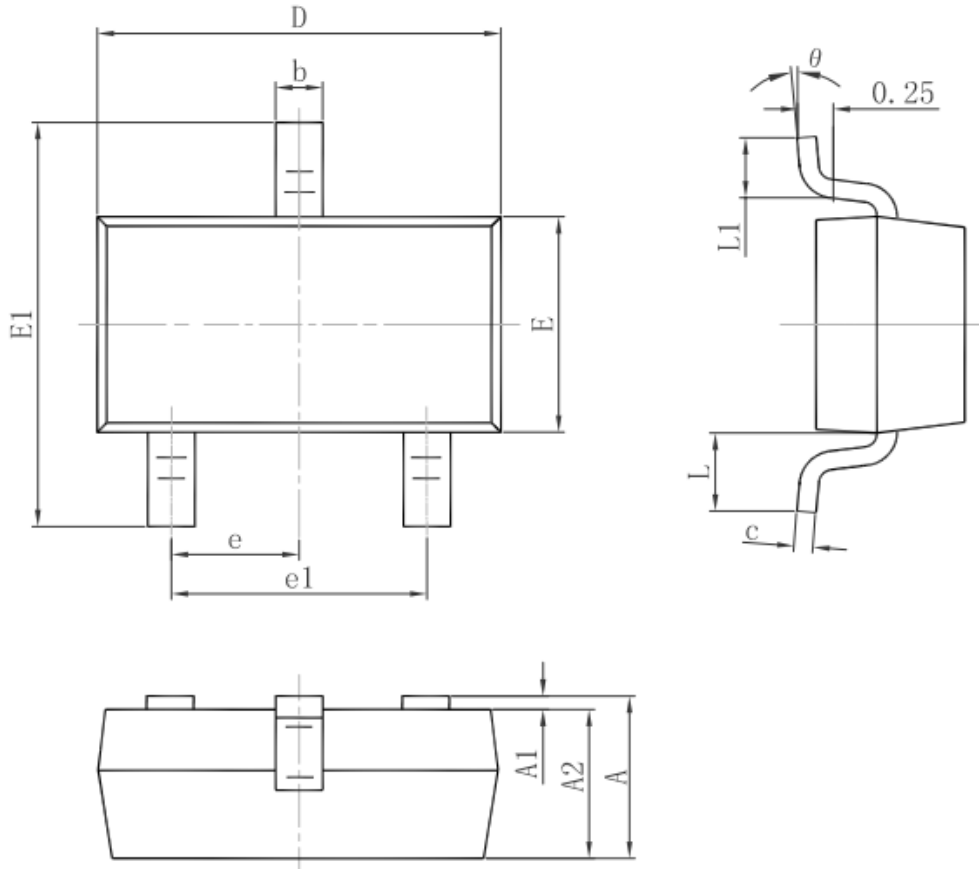

| Symbol | Dimensions In Millimeters | | Dimensions In Inches | |
|--------|---------------------------|-------|----------------------|-------|
| | Min. | Max. | Min. | Max. |
| A | 0.900 | 1.150 | 0.035 | 0.045 |
| A1 | 0.000 | 0.100 | 0.000 | 0.004 |
| A2 | 0.900 | 1.050 | 0.035 | 0.041 |
| b | 0.300 | 0.500 | 0.012 | 0.020 |
| c | 0.080 | 0.150 | 0.003 | 0.006 |
| D | 2.800 | 3.000 | 0.110 | 0.118 |
| E | 1.200 | 1.400 | 0.047 | 0.055 |
| E1 | 2.250 | 2.550 | 0.089 | 0.100 |
| e | 0.950 TYP. | | 0.037 TYP. | |
| e1 | 1.800 | 2.000 | 0.071 | 0.079 |
| L | 0.550 REF. | | 0.022 REF. | |
| L1 | 0.300 | 0.500 | 0.012 | 0.020 |
| θ | 0° | 8° | 0° | 8° |

3-pin SOT23-3 Outline Dimensions

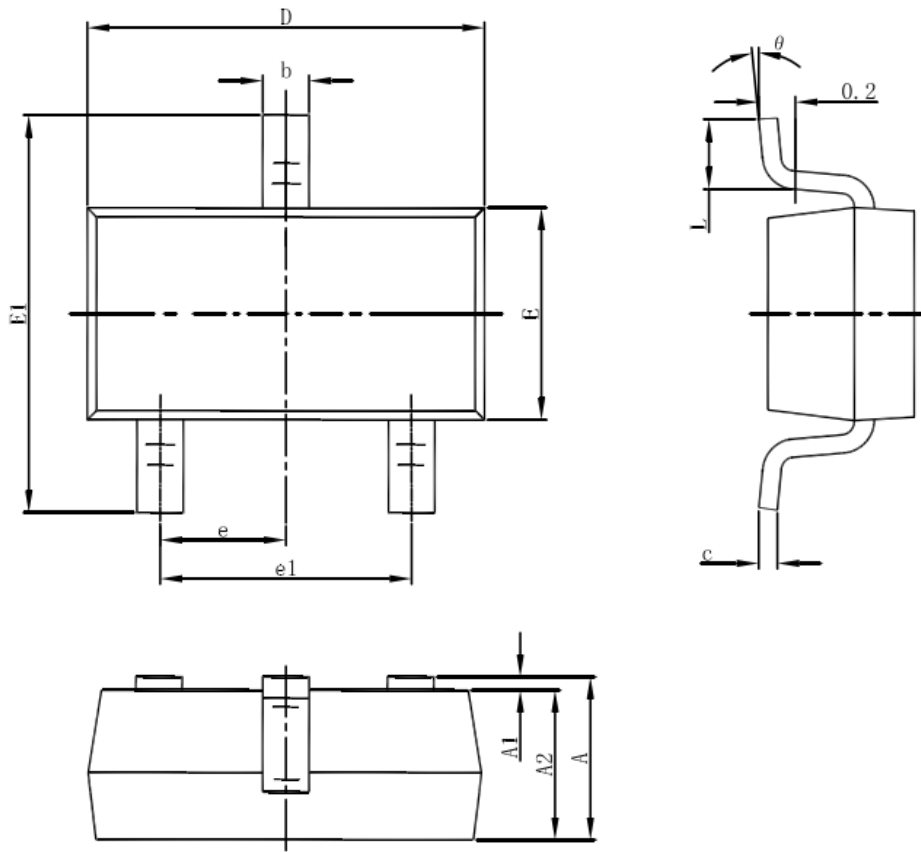

| Symbol | Dimensions In Millimeters | | Dimensions In Inches | |
|--------|---------------------------|-------|----------------------|-------|
| | Min | Max | Min | Max |
| A | 1.050 | 1.250 | 0.041 | 0.049 |
| A1 | 0.000 | 0.100 | 0.000 | 0.004 |
| A2 | 1.050 | 1.150 | 0.041 | 0.045 |
| b | 0.300 | 0.500 | 0.012 | 0.020 |
| c | 0.100 | 0.200 | 0.004 | 0.008 |
| D | 2.820 | 3.020 | 0.111 | 0.119 |
| E | 1.500 | 1.700 | 0.059 | 0.067 |
| E1 | 2.650 | 2.950 | 0.104 | 0.116 |
| e | 0.950(BSC) | | 0.037(BSC) | |
| e1 | 1.800 | 2.000 | 0.071 | 0.079 |
| L | 0.300 | 0.600 | 0.012 | 0.024 |
| θ | 0° | 8° | 0° | 8° |

3-pin SOT89 Outline Dimensions

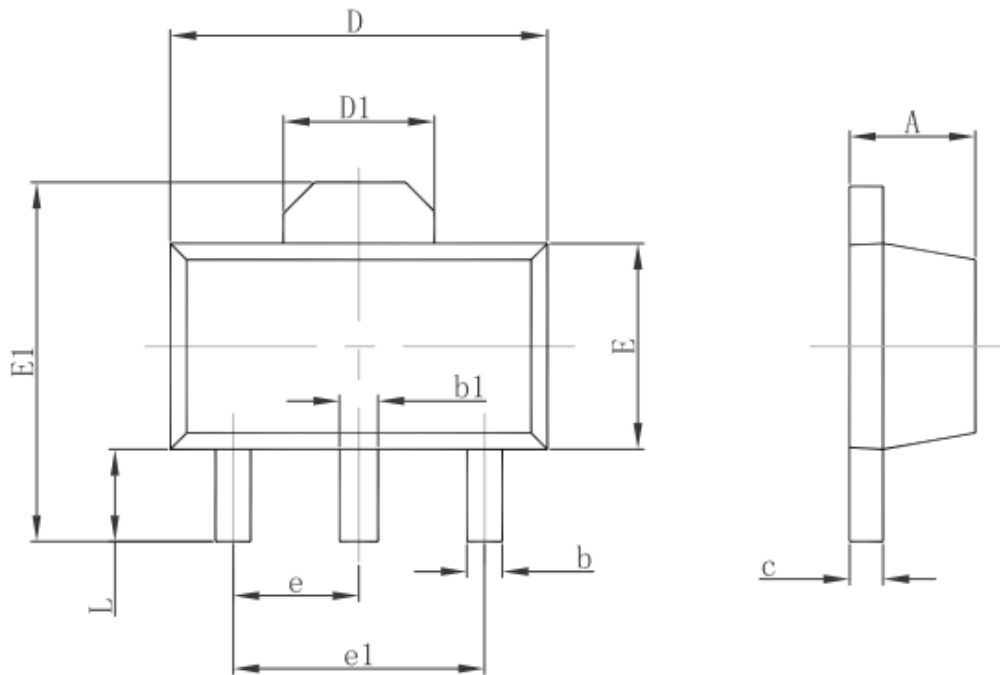

| Symbol | Dimensions In Millimeters | | Dimensions In Inches | |
|--------|---------------------------|-------|----------------------|-------|
| | Min. | Max. | Min. | Max. |
| A | 1.400 | 1.600 | 0.055 | 0.063 |
| b | 0.320 | 0.520 | 0.013 | 0.020 |
| b1 | 0.400 | 0.580 | 0.016 | 0.023 |
| c | 0.350 | 0.440 | 0.014 | 0.017 |
| D | 4.400 | 4.600 | 0.173 | 0.181 |
| D1 | 1.550 REF. | | 0.061 REF. | |
| E | 2.300 | 2.600 | 0.091 | 0.102 |
| E1 | 3.940 | 4.250 | 0.155 | 0.167 |
| e | 1.500 TYP. | | 0.060 TYP. | |
| e1 | 3.000 TYP. | | 0.118 TYP. | |
| L | 0.900 | 1.200 | 0.035 | 0.047 |