



SGM41523/SGM41523A/B/C/D Compact Switch, 2.5A Standalone Single-Cell Battery Charger with Safe and Reliable Charging

GENERAL DESCRIPTION

The SGM41523/SGM41523A/SGM41523B/SGM41523C/SGM41523D are compact switch standalone battery chargers for single-cell Li-Ion or Li-polymer battery. They are featured with resistor programmable maximum charge current, ordering selections of preset end of charge current and pre-charge current and floating time out. The SGM41523/SGM41523A/SGM41523B/SGM41523C/SGM41523D also have other safety features, such as over-voltage and over-current protections, fold-back retaining, input under-voltage lockout, battery temperature monitoring and thermal shutdown. These features ensure safe and reliable operation, ease of design and a comfortable user experience.

The SGM41523/SGM41523A/SGM41523B/SGM41523C/SGM41523D are available in a Green TDFN-3×3-12L package. They operate over an ambient temperature range of -40°C to +85°C.

APPLICATIONS

Portable Audio Speaker
Mobile Phone
Wearables
EPOS

FEATURES

- Maximum 2.5A Charging for 4.1V to 4.45V Battery
- 1.33MHz Switch Frequency
- Up to 95.7% Charge Efficiency
- 93% Charge Efficiency at 1.5A from 5V Input
- 91% Charge Efficiency at 1.5A from 9V Input
- Charging Voltage and Current Programmable
- CC/CV Interface for Charge Current and Battery Voltage Settings
- 4.2V Input Voltage Regulation
- 4.2V to 12V Operating Input Voltage Range
- Up to 18V Sustainable Voltage
- 13.5V Over-Voltage Protection with 100ns Turn-Off Timer
- Output Voltage Fold-Back Retaining
- Optional High or Low Charge Enable
 - ◆ Active Low (SGM41523/SGM41523A/SGM41523D)
 - ◆ Active High (SGM41523B/SGM41523C)
- JEITA Guideline Compliance
 - ◆ T2 Threshold 10°C (SGM41523/SGM41523B/SGM41523D)
 - ◆ T2 Threshold 15°C (SGM41523A/SGM41523C)
 - ◆ Charge Prohibited when > T3 (SGM41523D)
- -40°C to +85°C Operating Temperature Range
- Available in a Green TDFN-3×3-12L Package

PACKAGE/ORDERING INFORMATION

MODEL	PACKAGE DESCRIPTION	SPECIFIED TEMPERATURE RANGE	ORDERING NUMBER	PACKAGE MARKING	PACKING OPTION
SGM41523	TDFN-3x3-12L	-40°C to +85°C	SGM41523YTDF12G/TR	SGM 41523DF XXXXX	Tape and Reel, 4000
SGM41523A	TDFN-3x3-12L	-40°C to +85°C	SGM41523AYTDF12G/TR	SGM SGXDF XXXXX	Tape and Reel, 4000
SGM41523B	TDFN-3x3-12L	-40°C to +85°C	SGM41523BYTDF12G/TR	SGM SGYDF XXXXX	Tape and Reel, 4000
SGM41523C	TDFN-3x3-12L	-40°C to +85°C	SGM41523CYTDF12G/TR	SGM SGZDF XXXXX	Tape and Reel, 4000
SGM41523D	TDFN-3x3-12L	-40°C to +85°C	SGM41523DYTDF12G/TR	SGM 03HDF XXXXX	Tape and Reel, 4000

MARKING INFORMATION

NOTE: XXXXX = Date Code, Trace Code and Vendor Code.

XXXXX

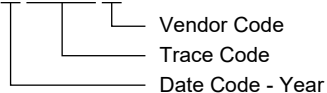

Green (RoHS & HSF): SG Micro Corp defines "Green" to mean Pb-Free (RoHS compatible) and free of halogen substances. If you have additional comments or questions, please contact your SGMICRO representative directly.

DEVICE COMPARISON TABLE

Part No.	Charge Enable (CE)	T2 Threshold	Charge Range
SGM41523	Low	10°C	T1 ~ T4
SGM41523A	Low	15°C	T1 ~ T4
SGM41523B	High	10°C	T1 ~ T4
SGM41523C	High	15°C	T1 ~ T4
SGM41523D	Low	10°C	T1 ~ T3

ABSOLUTE MAXIMUM RATINGS

Voltage Range (with Respect to GND)

VBUS (Converter Not Switching)	-2V to 18V
BTST (Converter Not Switching)	-0.3V to 18V
SW, BAT	-2V to 14V
BTST to SW	-0.3V to 6V
REGN, TS, CE (Converter Not Switching)	-0.3V to 6V
CC, CV, STAT	-0.3V to 6V

Output Sink Current

STAT	6mA
------	-----

Package Thermal Resistance

TDFN-3×3-12L, θ_{JA}	52°C/W
-----------------------------	--------

Junction Temperature

	+150°C
--	--------

Storage Temperature Range

	-65°C to +150°C
--	-----------------

Lead Temperature (Soldering, 10s)

	+260°C
--	--------

ESD Susceptibility

HBM	2000V
CDM	1000V

RECOMMENDED OPERATING CONDITIONS

Input Voltage Range, V_{VBUS}	4.2V to 12V
Input Current (VBUS), I_{IN}	2.5A (MAX)
Output Current (SW), I_{SWOP}	2.5A (MAX)
Battery Voltage, V_{BATOP}	4.45V (MAX)
Fast Charge Current, I_{CHGOP}	2.5A (MAX)
Ambient Temperature Range	-40°C to +85°C
Junction Temperature Range	-40°C to +125°C

OVERSTRESS CAUTION

Stresses beyond those listed in Absolute Maximum Ratings may cause permanent damage to the device. Exposure to absolute maximum rating conditions for extended periods may affect reliability. Functional operation of the device at any conditions beyond those indicated in the Recommended Operating Conditions section is not implied.

ESD SENSITIVITY CAUTION

This integrated circuit can be damaged if ESD protections are not considered carefully. SGMICRO recommends that all integrated circuits be handled with appropriate precautions. Failure to observe proper handling and installation procedures can cause damage. ESD damage can range from subtle performance degradation to complete device failure. Precision integrated circuits may be more susceptible to damage because even small parametric changes could cause the device not to meet the published specifications.

DISCLAIMER

SG Micro Corp reserves the right to make any change in circuit design, or specifications without prior notice.

PIN CONFIGURATION

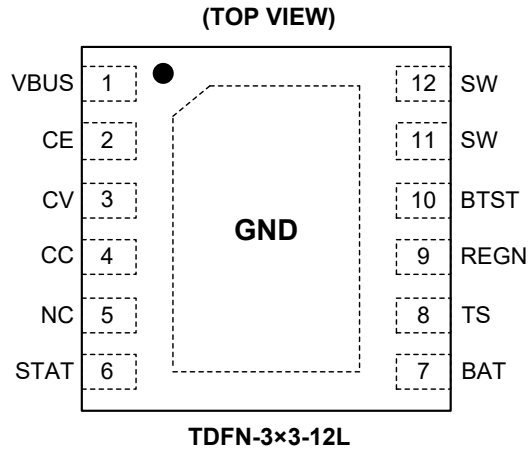

PIN DESCRIPTION

PIN	NAME	TYPE ⁽¹⁾	FUNCTION
1	VBUS	P	Charger Input and Voltage Sense. Connect a 10µF ceramic capacitor from VBUS pin to GND close to device.
2	CE	DI	Charge Enable Input Pin. When this pin is driven low for SGM41523/SGM41523A/SGM41523D or driven high for SGM41523B/SGM41523C, the battery charge is enabled.
3	CV	AI	Charge Voltage Programming Input Pin. Connect a resistor between this pin and GND, for feeding different voltages to select 6 different charge voltages.
4	CC	AI	Charge Current Programming and Charging Inhibition Input Pin. Connect a resistor between this pin and GND for programming the constant charge current by $I_{CHGREG} = K \cdot V_{REF}/R_{CC}$. Pull up this pin to a voltage higher than V_{CC_H} (1.4V) to stop charging.
5	NC	–	No Connection.
6	STAT	DO	Push-Pull Charge Status Output. The STAT pin acts as follows: During charge: low (LED1 ON, LED2 OFF). Charge completed or charger in sleep mode: high (LED1 OFF, LED2 ON). Charge suspended (in response to a fault): 0.65Hz, 50% duty cycle pulses (LEDs BLINKS).
7	BAT	P	Battery Positive Terminal Pin. Use a 22µF capacitor between BAT and GND pins close to the device.
8	TS	AI	Temperature Sense Input Pin. Connect to the battery NTC thermistor that is grounded on the other side. To program operating temperature window, it can be biased by a resistor divider between REGN and GND. Charge suspends if TS voltage goes out of the programmed range. It is recommended to use a 103AT-2 type thermistor. If NTC feature is not used, connect the NTC pin to ground. The device checks for NTC grounded once during start-up.
9	REGN	P	LDO Output that Powers LSFET Driver and Internal Circuits. Internally, the REGN pin is connected to the anode of the bootstrap diode. Place a 1µF (10V rating) ceramic capacitor between REGN pin and GND. It is recommended to place the capacitor close to the REGN pin.
10	BTST	P	High-side Driver Positive Supply. It is internally connected to the bootstrap diode cathode. Use a 10nF ceramic capacitor from SW pin to BTST pin.
11,12	SW	P	Switching Node Output. Connect SW pin to the output inductor. Connect the 10nF bootstrap capacitor from SW pin to BTST pin.
Exposed Pad	GND	P	Thermal Pad and Ground Reference. It is the ground reference for the device and also the thermal pad to conduct heat from the device (not suitable for high current return). Tie externally to the PCB ground plane (GND). Thermal vias under the pad are needed to conduct the heat to the PCB ground planes.

NOTE:

1. AI = Analog Input, AO = Analog Output, AIO = Analog Input and Output, DI = Digital Input, DO = Digital Output, DIO = Digital Input and Output, P = Power.

ELECTRICAL CHARACTERISTICS

($V_{VBUS_UVLOZ} < V_{VBUS} < V_{VBUS_OV}$ and $V_{VBUS} > V_{BAT} + V_{SLEEP}$, $T_J = -40^{\circ}C$ to $+85^{\circ}C$, typical values are at $T_J = +25^{\circ}C$, unless otherwise noted.)

PARAMETER	SYMBOL	CONDITIONS	MIN	TYP	MAX	UNITS	
Quiescent Currents							
Battery Discharge Current (BAT)	I_{BAT}	$V_{BAT} = 4.5V, V_{VBUS} < V_{VBUS_UVLOZ}$ or no VBUS		0.1	1.0	μA	
		$V_{BAT} = 4.5V, V_{VBUS} = 5V$, fold-back mode		4.5	7.0		
Input Supply Current (VBUS)	I_{VBUS}	$V_{VBUS} = 5V, V_{VBUS} > V_{BAT}$, converter not switching		1.4		mA	
		$V_{VBUS} = 12V, V_{VBUS} > V_{BAT}$, converter not switching		1.7	2.2		
		$V_{BAT} = 3.8V, V_{VBUS} > V_{BAT}, V_{VBUS} > V_{VBUS_UVLOZ}$, converter switching		8			
BAT Pin and VBUS Pin Power-Up							
VBUS Operating Range	V_{VBUS_OP}	V_{VBUS} rising	4.2		13.2	V	
VBUS for Device Active, No Battery Sense VBUS Pin Voltage	V_{VBUS_UVLOZ}	V_{VBUS} rising, $T_J = +25^{\circ}C$		3.32	3.46	V	
Device Active Hysteresis	$V_{VBUS_UVLOZ_HYS}$	V_{VBUS} falling from above V_{VBUS_UVLOZ}		70		mV	
Sleep Mode Falling Threshold	V_{SLEEP}	$V_{VBUS} - V_{BAT}, V_{VBUSMIN} \leq V_{BAT} \leq V_{REGN}, V_{VBUS}$ falling, $T_J = +25^{\circ}C$		80	165	mV	
Sleep Mode Rising Threshold	V_{SLEEPZ}	$V_{VBUS} - V_{BAT}, V_{VBUSMIN} \leq V_{BAT} \leq V_{REGN}, V_{VBUS}$ rising, $T_J = +25^{\circ}C$	100	175	260	mV	
VBUS 13V Over-Voltage Rising Threshold	$V_{VBUS_OV_RISE}$	V_{VBUS} rising	12.78	13.4	13.90	V	
VBUS 13V Over-Voltage Hysteresis	$V_{VBUS_OV_HYS}$	V_{VBUS} falling		355		mV	
Bad Adapter Detection Falling Threshold	$V_{VBUSMIN}$	V_{VBUS} falling	3.52	3.70	3.89	V	
Bad Adapter Detection Hysteresis	$V_{VBUSMIN_HYS}$			250		mV	
Bad Adapter Detection Current Source	I_{BAD_SRC}	Sink current from VBUS to GND, $T_J = +25^{\circ}C$	17	24	30	mA	
Power Path Management							
Total High-side MOSFET On-Resistance - (Q1 + Q2)	R_{ON_HSFET}	$V_{REGN} = 5V$		140		m Ω	
Low-side Switching MOSFET On-Resistance - Q3	R_{ON_LSFET}	$V_{REGN} = 5V$		100		m Ω	
Battery Charger							
Charge Voltage Program Range	V_{BATREG_RANGE}	$T_J = +25^{\circ}C$	4.10		4.45	V	
Charge Voltage Step	V_{BATREG_STEP}			50		mV	
Initial Charge Voltage Setting	V_{BATREG}	$R_{CV} = 0\Omega$ or floating (4.2V)	$T_J = +25^{\circ}C$	4.188	4.200	4.212	V
			$T_J = -40^{\circ}C$ to $+85^{\circ}C$	4.171	4.200	4.229	
		$R_{CV} = 22.1k\Omega$ (4.35V)	$T_J = +25^{\circ}C$	4.334	4.347	4.361	
			$T_J = -40^{\circ}C$ to $+85^{\circ}C$	4.317	4.347	4.378	
Charge Current Regulation Range	I_{CHGREG_RANGE}		0		2500	mA	
Initial Charge Current Regulation Setting	I_{CHGREG}	$V_{BAT} = 3.8V$	$I_{CHGREG} = 0.515A, T_J = +25^{\circ}C$	0.475	0.510	0.550	A
				-6.7		8.0	%
			$I_{CHGREG} = 1.235A, T_J = +25^{\circ}C$	1.19	1.23	1.28	A
				-3.6		3.5	%
$I_{CHGREG} = 1.535A, T_J = +25^{\circ}C$	1.480	1.535	1.580	A			
	$I_{CHGREG} = 1.535A, T_J = -40^{\circ}C$ to $+85^{\circ}C$	1.455	1.535	1.605	A		
Initial Pre-Charge Current Regulation Setting	I_{PRECHG}	$V_{BAT} = 2.6V, T_J = +25^{\circ}C, I_{PRECHG}$ is 10% of I_{CHGREG}	$I_{CHGREG} = 0.515A$	31	55	88	mA
			$I_{CHGREG} = 1.235A$	101	130	163	

ELECTRICAL CHARACTERISTICS (continued)

($V_{VBUS_UVLOZ} < V_{VBUS} < V_{VBUS_OV}$ and $V_{VBUS} > V_{BAT} + V_{SLEEP}$, $T_J = -40^{\circ}\text{C}$ to $+85^{\circ}\text{C}$, typical values are at $T_J = +25^{\circ}\text{C}$, unless otherwise noted.)

PARAMETER	SYMBOL	CONDITIONS	MIN	TYP	MAX	UNITS	
Battery Charger							
Battery LOW Falling Threshold	V_{BATLOW_FALL}	$I_{CHGREG} = 600\text{mA}$, $T_J = +25^{\circ}\text{C}$	2.68	2.79	2.91	V	
Battery LOW Rising Threshold	V_{BATLOW_RISE}	Pre-charge to fast charge		3.10		V	
Initial Termination Current Regulation Setting	I_{TERM}	$V_{BAT} = 4.1\text{V}$, $T_J = +25^{\circ}\text{C}$, I_{TERM} is 10% of I_{CHGREG}	$I_{CHGREG} = 0.515\text{A}$	21.5	51	80.5	mA
			$I_{CHGREG} = 1.235\text{A}$	92.5	123	154	
Initial Battery Short Voltage	V_{SHORT}	V_{BAT} falling, $T_J = +25^{\circ}\text{C}$	2.02	2.05	2.09	V	
	V_{SHORTZ}	V_{BAT} rising, $T_J = +25^{\circ}\text{C}$	2.15	2.19	2.22		
Initial Battery Short Current	I_{SHORT}	$V_{BAT} < V_{SHORTZ}$	30	33.5	38	mA	
Fold-Back Mode Threshold below V_{BATREG}	$V_{FOLDBACK}$	V_{BAT} falling		90		mV	
Recharge Threshold below V_{BATREG}	V_{RECHG}	V_{BAT} falling, $T_J = +25^{\circ}\text{C}$	85	140	190	mV	
Charge Current Amplification Ratio	K			10300			
Constant Current Control Reference Voltage	V_{REF}			1		V	
Input Voltage Regulation							
Input Voltage Regulation Limit	V_{INDPM}	LVDPM version		4.16		V	
BAT Pin Over-Voltage Protection							
Battery Over-Voltage Threshold	V_{BATOVP_RISE}	As percentage of V_{BATREG} , $T_J = +25^{\circ}\text{C}$	V_{BAT} rising	103	104.5	106	%
	V_{BATOVP_FALL}		V_{BAT} falling	101	102.5	104	
Thermal Regulation and Thermal Shutdown							
Junction Temperature Regulation Threshold	$T_{JUNCTION_REG}$	Temperature increasing		110		$^{\circ}\text{C}$	
Thermal Shutdown Rising Temperature	T_{SHUT}	Temperature increasing		150		$^{\circ}\text{C}$	
Thermal Shutdown Hysteresis	T_{SHUT_HYS}			10		$^{\circ}\text{C}$	
JEITA Thermistor Comparator							
T1 (0 $^{\circ}\text{C}$) Threshold Voltage on TS Pin	V_{T1}	Charger suspends if temperature T is below T1 ($T < T1$), as percentage to V_{REGN}		73.2		%	
V_{T1} Falling			As percentage of V_{REGN}		71.3		%
T2 (10 $^{\circ}\text{C}$) Threshold Voltage on TS Pin	V_{T2}	Charge back to $I_{CHGREG}/10$ and $V_{BATREG} - 100\text{mV}$ if $T1 < T < T2$, as percentage of V_{REGN} (SGM41523/SGM41523B/SGM41523D)		68.1		%	
V_{T2} Falling			As percentage of V_{REGN} (SGM41523/SGM41523B/SGM41523D)		66.6		%
T2 (15 $^{\circ}\text{C}$) Threshold Voltage on TS Pin	V_{T2}	Charge back to $I_{CHGREG}/10$ and $V_{BATREG} - 100\text{mV}$ if $T1 < T < T2$, as percentage of V_{REGN} (SGM41523A/SGM41523C)		65.1		%	
V_{T2} Falling			As percentage of V_{REGN} (SGM41523A/SGM41523C)		63.3		%
V_{T3} Rising	V_{T3}	As percentage of V_{REGN}		46.0		%	
T3 (45 $^{\circ}\text{C}$) Threshold Voltage on TS Pin			Charge back to $I_{CHGREG}/10$ and $V_{BATREG} - 100\text{mV}$ if $T3 < T < T4$, as percentage to V_{REGN}		44.2		%
V_{T4} Rising	V_{T4}	As percentage of V_{REGN}		35.8		%	
T4 (60 $^{\circ}\text{C}$) Threshold Voltage on TS Pin			Charge suspended if $T > T4$, as percentage of V_{REGN}		34.6		%

ELECTRICAL CHARACTERISTICS (continued)

($V_{VBUS_UVLOZ} < V_{VBUS} < V_{VBUS_OV}$ and $V_{VBUS} > V_{BAT} + V_{SLEEP}$, $T_J = -40^{\circ}C$ to $+85^{\circ}C$, typical values are at $T_J = +25^{\circ}C$, unless otherwise noted.)

PARAMETER	SYMBOL	CONDITIONS	MIN	TYP	MAX	UNITS
Charge Over-Current Comparator (Cycle-by-Cycle)						
HSFET Cycle-by-Cycle Over-Current Threshold	I_{HSFET_OCP}			4		A
Charge Under-Current Comparator (Cycle-by-Cycle)						
LSFET Under-Current Falling Threshold	V_{LSFET_UCP}	From sync mode to non-sync mode		100		mA
PWM						
PWM Switching Frequency	f_{SW}	Oscillator frequency, Buck mode, $T_J = +25^{\circ}C$	1.20	1.33	1.45	MHz
Maximum PWM Duty Cycle	D_{MAX}			98		%
REGN LDO						
REGN LDO Output Voltage	V_{REGN}	$V_{VBUS} = 9V, I_{REGN} = 40mA$	4.70	4.90	5.10	V
		$V_{VBUS} = 5V, I_{REGN} = 20mA$	4.79	4.86	4.92	
REGN LDO Maximum Output Current	I_{REGN_MAX}	$V_{VBUS} = 5V$	56	68	80	mA
Logic I/O Pin Characteristics (nCE)						
Input Low Threshold	V_{IL}				0.2	V
Input High Threshold	V_{IH}		0.8			V
High-Level Leakage Current	I_{BIAS}	Pull up rail 1.8V		0.1		μA
Logic I/O Pin Characteristics (STAT)						
High-Level Output Voltage	V_{OH}		4.6			V
Low-Level Output Voltage	V_{OL}				0.3	V
Output or Sink Current Ability	I_{STAT}			3.3		mA

TIMING REQUIREMENTS

PARAMETER	SYMBOL	CONDITIONS	MIN	TYP	MAX	UNITS
V_{VBUS}/V_{BAT} Power-Up						
VBUS OVP Reaction Time	t_{ACOV}	V_{VBUS} rising above ACOV threshold to turn off Q2		100		ns
Wait Window for Bad Adapter Detection	t_{BAD_SRC}			42		ms
Battery Charger						
Deglitch Time for Charge Termination	t_{TERM_DGL}			168		ms
Deglitch Time for Recharge	t_{RECHG_DGL}			168		ms
Battery Over-Voltage Deglitch Time to Disable Charge	t_{BATOVp}			1		μs

TYPICAL PERFORMANCE CHARACTERISTICS

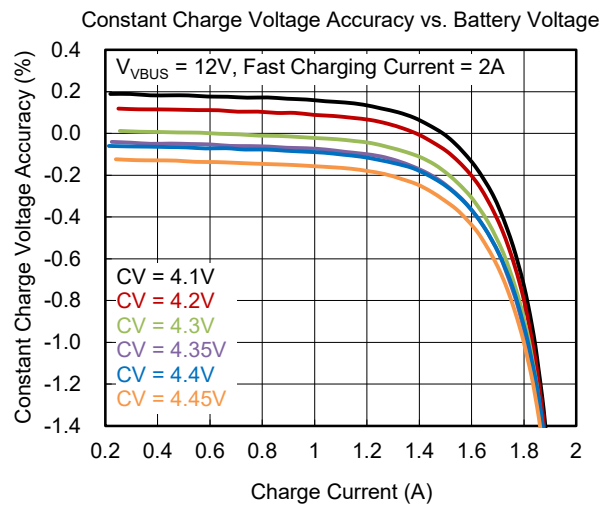
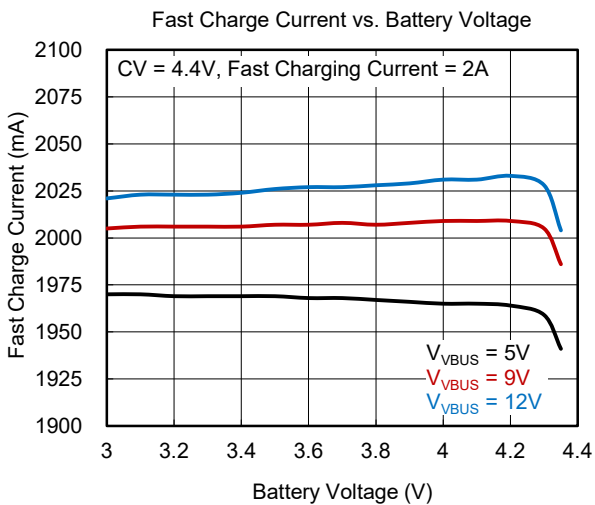
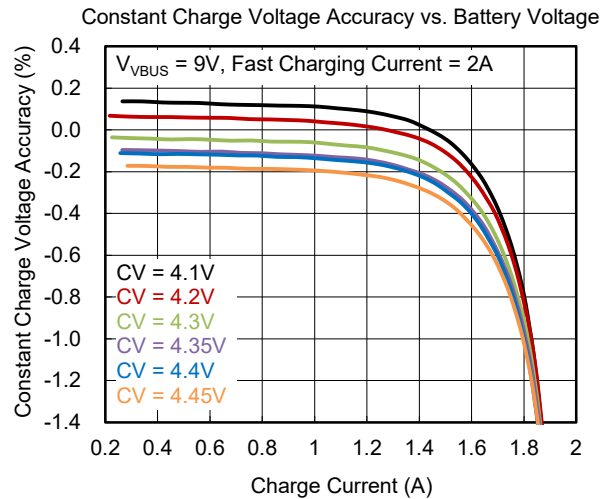
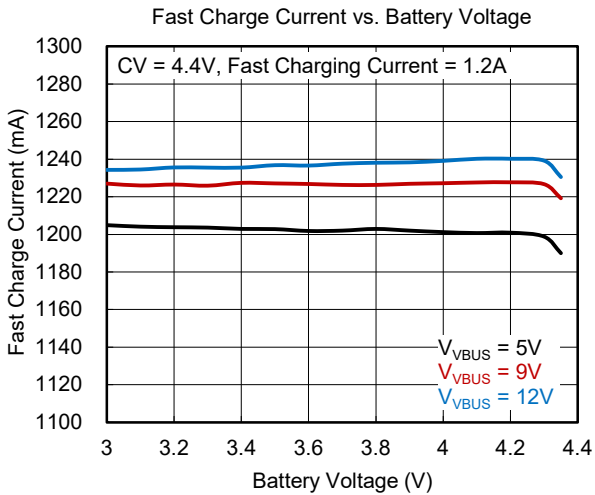
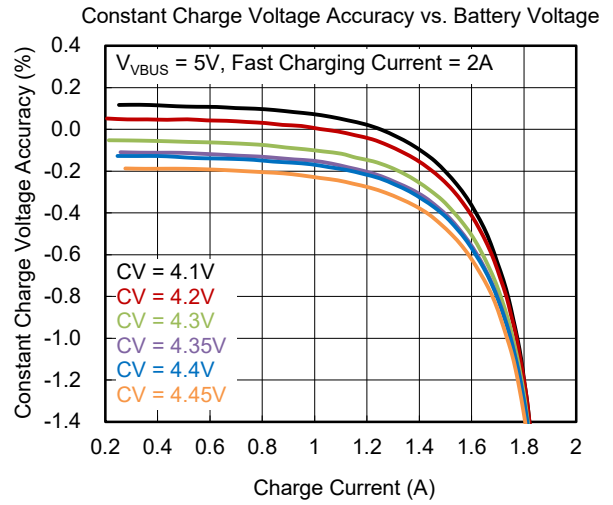
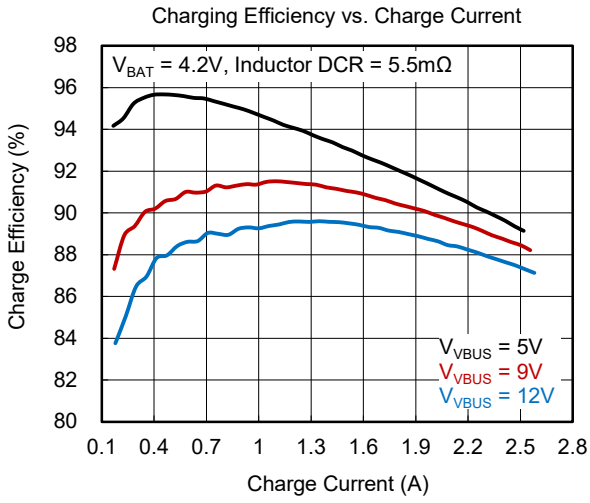

TYPICAL PERFORMANCE CHARACTERISTICS (continued)

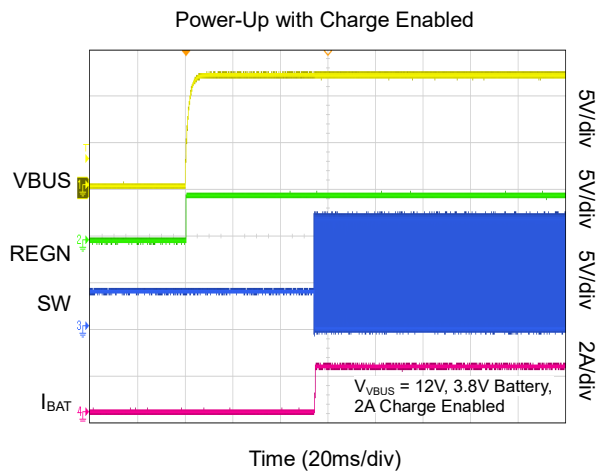
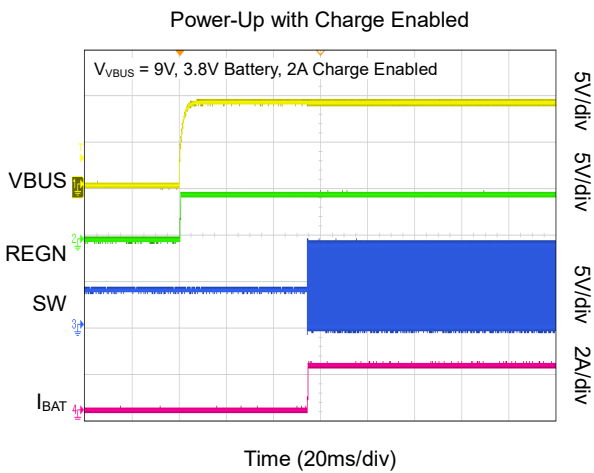
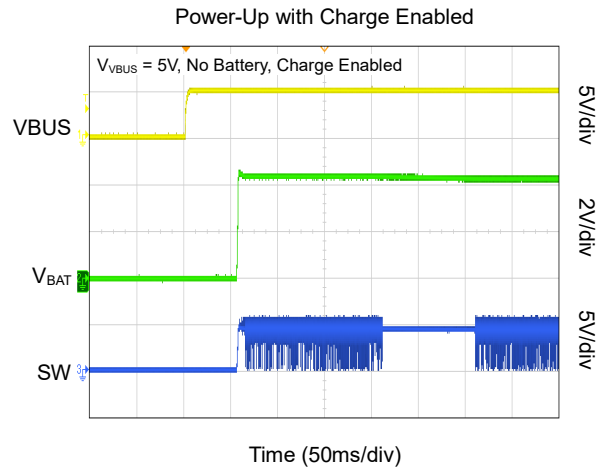
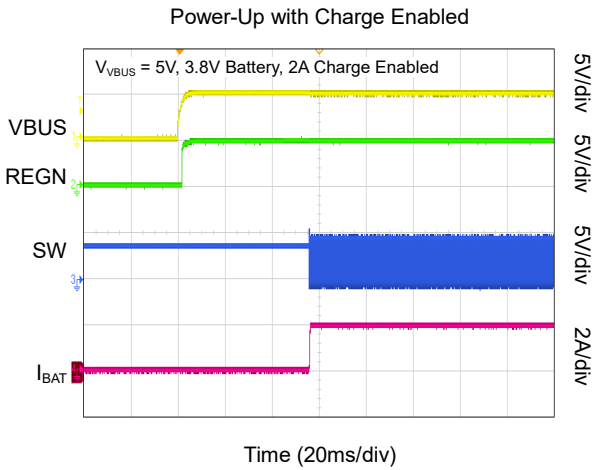
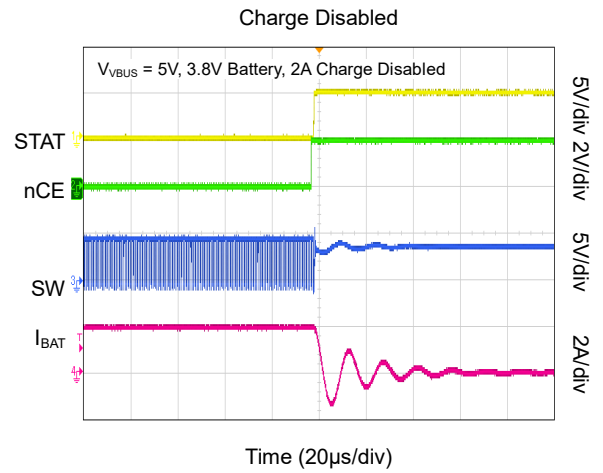
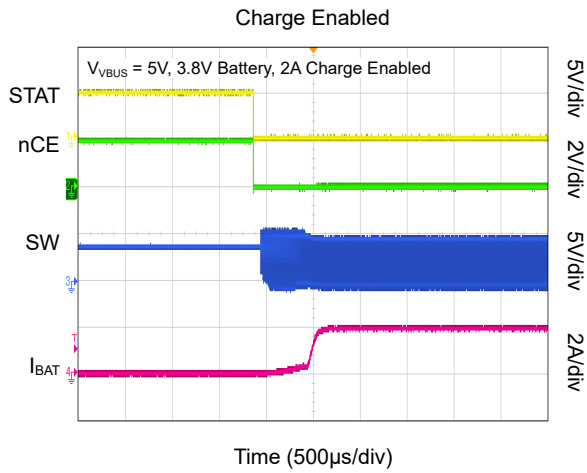

TYPICAL APPLICATION CIRCUIT

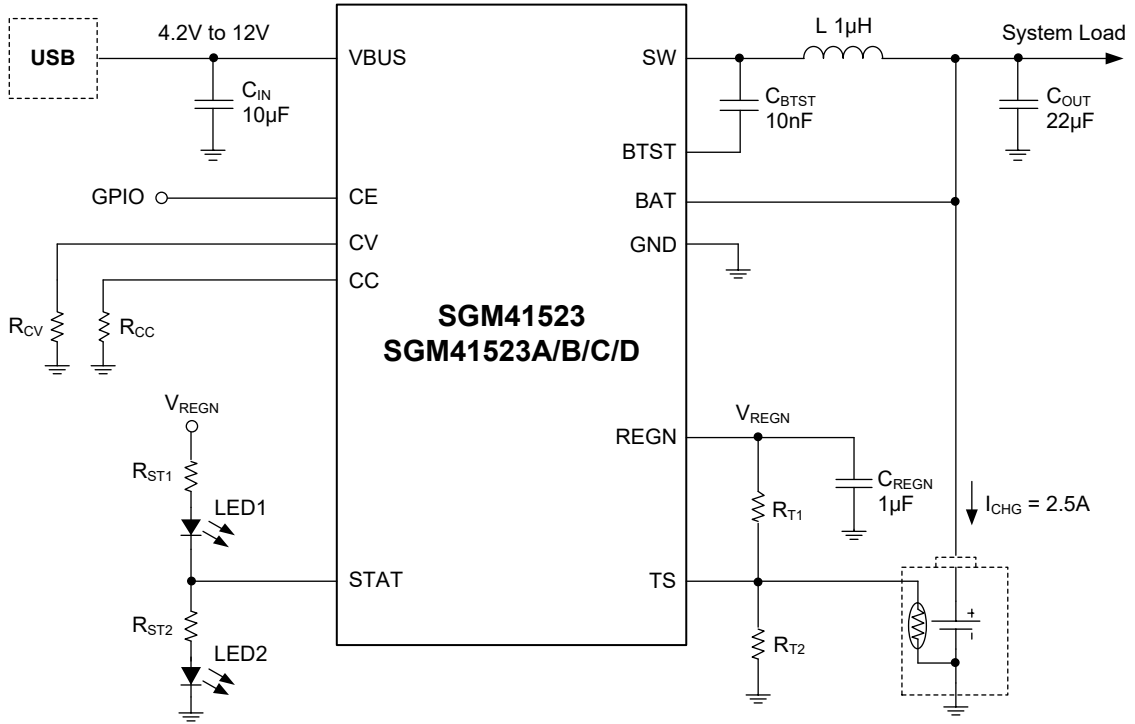

Figure 1. Typical Application Circuit

FUNCTIONAL BLOCK DIAGRAM

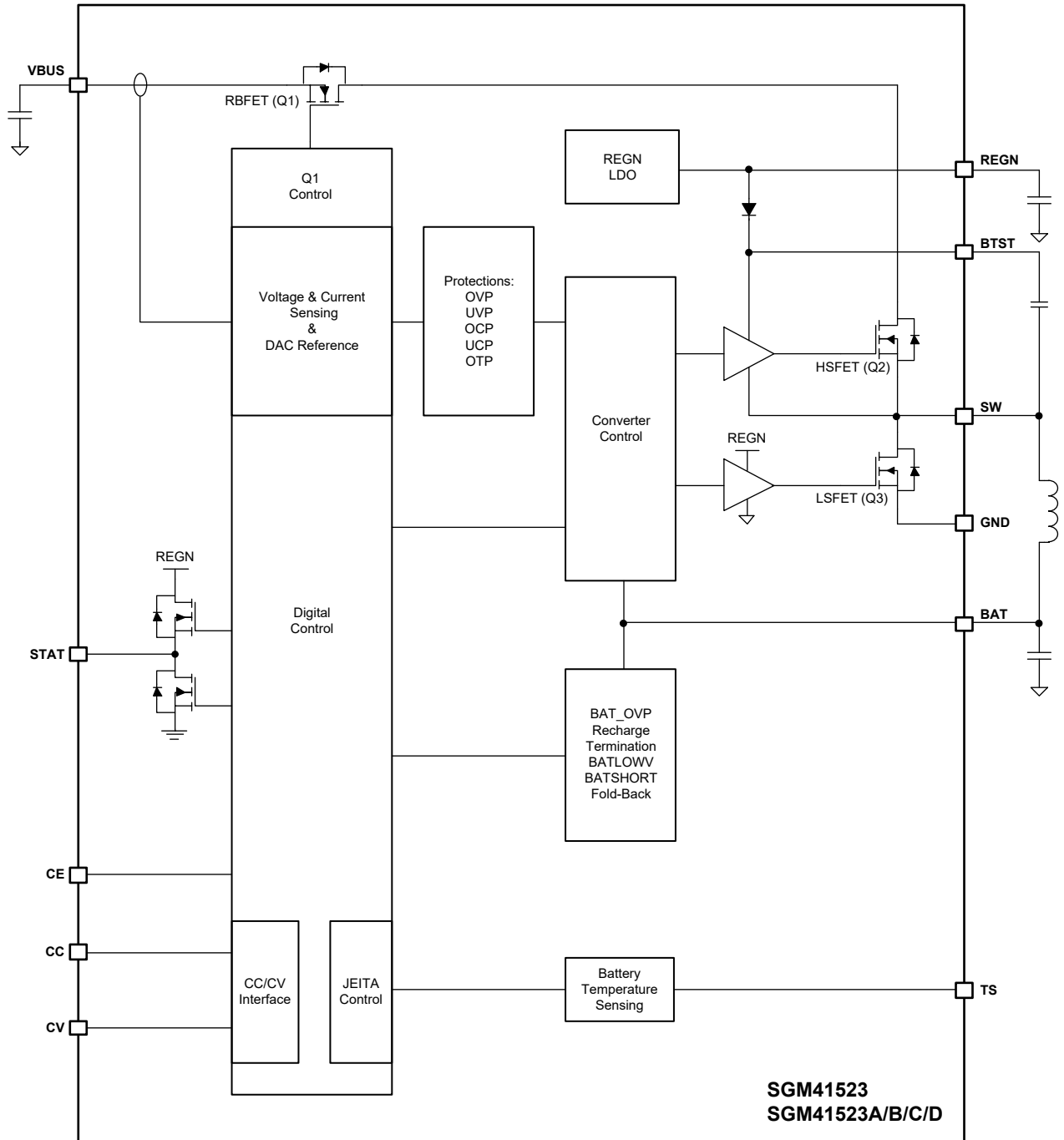

Figure 2. Block Diagram

DETAILED DESCRIPTION

Overview

The SGM41523/SGM41523A/SGM41523B/SGM41523C/SGM41523D are highly-integrated 2.5A switch-mode standalone battery charge management devices for applications such as cell phones, tablets and portable devices that use single-cell Li-Ion and Li-polymer batteries. The devices have a low impedance power path that improves the operation efficiency of the switch-mode, reduces the battery charging time and extends battery life in the discharging phase. The charging setting with the CC/CV interface makes the device a flexible solution. These devices include three main power switches: input reverse blocking FET (RBFET, Q1), high-side switching FET (HSFET, Q2) and low-side switching FET (LSFET, Q3). The bootstrap diode of the high-side gate drive is also integrated to simplify the system design.

The start and termination of a charging cycle can be accomplished without software control. The sensed battery voltage is used to decide the starting phase of charge in one of the three phases of charge cycle: pre-conditioning, constant current or constant voltage. When the charge current falls below a preset limit and the battery voltage is above recharge threshold, the charger function will automatically terminate and end the charging cycle. When the voltage of a charged battery is below the recharge threshold, the charger starts another charging cycle.

The SGM41523/SGM41523A/SGM41523B/SGM41523C/SGM41523D have several safety features, such as over-voltage and over-current protections, battery temperature monitoring, input UVLO and thermal shutdown. TS pin is connected to an NTC thermistor for battery temperature monitoring and protection in charge mode

according to JEITA profile. This device also features thermal regulation in which the charge current is reduced if the junction temperature exceeds 110°C. The STAT output can report the status of the charge and any fault conditions.

Power-On Reset (POR)

The internal circuit of the device is powered from the voltage V_{BUS} . When the voltage of V_{BUS} goes above its UVLO level ($V_{BUS} > V_{BUS_UVLOZ}$), a POR happens and activates the sleep comparator. Upon activation, the CC/CV interface will also be ready for charge current and voltage settings.

Battery Charging Management

Battery Charging Profile

The SGM41523/SGM41523A/SGM41523B/SGM41523C/SGM41523D feature a full battery charging profile with five phases. In the beginning of the cycle, the battery voltage (V_{BAT}) is tested and appropriate current and voltage regulation levels are selected as shown in Table 1. Depending on the detected status of the battery, the proper phase is selected to start or for continuation of the charging cycle. The phases are trickle charge ($V_{BAT} < 2.19V$), pre-charge, fast-charge (constant current and constant voltage) and fold-back mode.

Table 1. Charge Current Setting Based on V_{BAT}

V_{BAT} Voltage	Charge Current
< 2.19V	I_{SHORT}
2.19V to 3V	I_{PRECHG}
> 3V	I_{CHGREG}

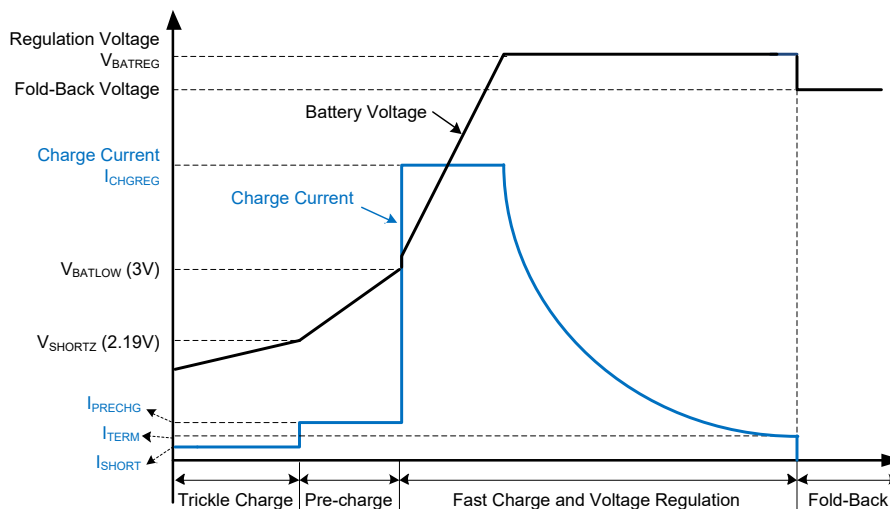

Figure 3. Battery Charging Profile

DETAILED DESCRIPTION (continued)

Charge Termination

A charge cycle is terminated when the battery voltage is higher than the recharge threshold and the charge current falls below the programmed termination current. The termination current is programmed to $I_{CHGREG}/10$ with a minimum clamped value of 50mA (TYP). To fully charge a battery, it is recommended to set the I_{CHGREG} to be much higher than 50mA. After the charging cycle is completed, the converter enters fold-back mode.

The SGM41523/SGM41523A/SGM41523B/SGM41523C/SGM41523D have no battery switch but provide an alternative way for battery safe and extended battery life, which is the voltage fold-back mode when a battery is fully charged while the input power is kept. This alternative has less energy loss as no switch in the discharge loop. The only penalty is that it could not support instant start if the battery voltage is excessive low, in which condition it takes a few more minutes for the load system to be ready for start. When the device operates in FBM, the output voltage $V_{FOLDBACK}$ is lower than V_{BATREG} , and the output current limit is $I_{CHGREG_FOLDBACK}$ (2.4A).

Compliance with JEITA Guideline

JEITA guideline (April 20, 2007 release) is implemented in the device for safe charging of the Li-Ion battery. JEITA highlights the considerations and limits that should be considered for charging at cold or hot battery temperatures. High charge current and voltage must be avoided outside normal operating temperatures (typically 0 °C and 60 °C). This functionality can be disabled if not needed. Four temperature levels are defined by JEITA from T1 (minimum) to T4 (maximum). Outside this range, charging should be stopped. The corresponding voltages sensed by NTC are named V_{T1} to V_{T4} . Due to the sensor negative resistance, a higher temperature results in a lower voltage on TS pin. The battery cool range is between T1 and T2, and the warm range is between T3 and T4. Charge must be limited in the cool and warm ranges.

One of the conditions for starting a charge cycle is having the TS voltage within V_{T1} to V_{T4} window limits. If during the charge, battery gets too cold or too hot and TS voltage exceeds the T1 - T4 limits, charging is suspended (zero charge current) and the controller waits for the battery temperature to come back within the T1 to T4 window.

At cool temperature (T1 - T2) or at warm temperature (T3 - T4), the charge current reduces to 10% of the charge current, and the charge voltage is decreased by about 100mV automatically. Particularly, the SGM41523D is charge prohibited at warm temperature.

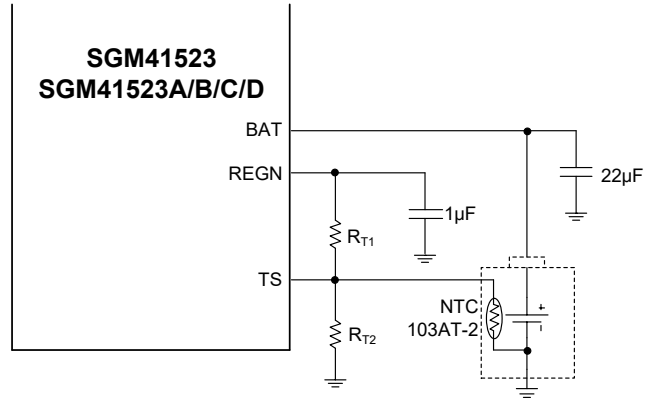

Figure 4. Battery Thermistor Connection and Bias Network

The resistor bias network (see Figure 4) can be calculated based on the following equations:

$$R_{T2} = \frac{R_{THCOLD} \times R_{THHOT} \times \left(\frac{1}{V_{T1}} - \frac{1}{V_{T4}} \right)}{R_{THHOT} \times \left(\frac{1}{V_{T4}} - 1 \right) - R_{THCOLD} \times \left(\frac{1}{V_{T1}} - 1 \right)} \quad (1)$$

$$R_{T1} = \frac{\left(\frac{1}{V_{T1}} - 1 \right)}{\left(\frac{1}{R_{T2}} \right) + \left(\frac{1}{R_{THCOLD}} \right)} \quad (2)$$

where V_{T1} and V_{T4} are T_{COLD} and T_{HOT} threshold voltage on TS pin as percentage to V_{REGN} . Select $T_{COLD} = 0^\circ\text{C}$ and $T_{HOT} = 60^\circ\text{C}$ for Li-Ion or Li-polymer batteries. For a 103AT-2 type thermistor $R_{THCOLD} = 27.28\text{k}\Omega$ and $R_{THHOT} = 3.02\text{k}\Omega$, the calculation results are: $R_{T1} = 5.18\text{k}\Omega$ and $R_{T2} = 29.34\text{k}\Omega$. The standard value is 5.23kΩ for R_{T1} and 29.4kΩ for R_{T2} .

Table 2. Temperature Related Charging Control

Temperature Range	Charge Current	Charge Voltage
Lower than T1	/	/
T1 - T2	$I_{CHGREG} \times 10\%$	$V_{BATREG} - 100\text{mV}$
T2 - T3	I_{CHGREG}	V_{BATREG}
T3 - T4 (SGM41523/SGM41523A/ SGM41523B/SGM41523C)	$I_{CHGREG} \times 10\%$	$V_{BATREG} - 100\text{mV}$
T3 - T4 (SGM41523D)	/	/
Higher than T4	/	/

DETAILED DESCRIPTION (continued)

Charging Status (STAT Pin)

Charging state is indicated with the push-pull STAT pin as explained in Table 3. This pin is able to drive two LEDs (see Figure 1).

Table 3. STAT Pin Function

Charging State	STAT Indicator
Charging battery (or recharge)	Low (LED1 ON, LED2 OFF)
Charging completed	High (LED1 OFF, LED2 ON)
Charging is disabled or in sleep mode	High (LED1 OFF, LED2 ON)
Charge is suspended due to input over-voltage, TS fault, or battery over-voltage	0.65Hz Blinking

Protections Features

Input Over-Voltage

If VBUS voltage exceeds V_{VBUS_OV} , switching will stop immediately. Charger resumes its normal operation when the voltage comes back below OVP limit.

Thermal Regulation and Thermal Shutdown

Internal junction temperature (T_J) is always monitored to avoid overheating. A limit of $+110^\circ\text{C}$ is considered for maximum IC surface temperature in Buck mode and if T_J intends to exceed this level, the device reduces the charge current to keep maximum temperature limited to $+110^\circ\text{C}$ (thermal regulation mode). As expected, the actual charging current is usually lower than programmed value during thermal regulation.

If the junction temperature exceeds T_{SHUT} ($+150^\circ\text{C}$), thermal shutdown protection arises in which the converter is turned off.

When the device recovers and T_J falls below the hysteresis band of T_{SHUT_HYS} (10°C under T_{SHUT}), the converter resumes automatically.

Battery Over-Voltage Protection

The over-voltage limit for the battery is 4.5% above the battery regulation voltage setting. Charging will immediately disable if a battery over-voltage occurs.

Battery Over-Discharge Protection

To recover from over-discharge, an input source is required at VBUS pin. The battery is charged with I_{SHORT} (33.5mA TYP) when the $V_{BAT} < V_{SHORT}$, or with a pre-charge current when the battery voltage is between V_{SHORT} and V_{BATLOW} .

Charging Voltage Programming

Forcing a voltage on the CV pin, or grounding it with a resistor that presents a similar voltage against the constant current sourcing from the pin during charging selects 1 of 6 charging voltages, as shown in Table 4.

Charge Current Programming and Turn-Off

Charge current is programmed by using different R_{CC} resistance or by providing voltage difference on the R_{CC} by forcing a voltage on the other end, which could be generated by a DAC or PWM output.

Forcing the CC to a voltage higher than V_{CC_H} (1.4V) turns the device off.

Table 4. Conditions for Selecting a Charging Voltage

Charging Voltage (V)	Forcing Voltage (V)	Separation Thresholds (V)	Recommended Grounding Resistance (k Ω)
4.1	0.45	0.3 ~ 0.6	9.09
4.2	Grounding or Open	< 0.3 or > 2.0	Grounding or Floating
4.3	0.75	0.6 ~ 0.9	15
4.35	1.05	0.9 ~ 1.2	21
4.4	1.4	1.2 ~ 1.6	28
4.45	1.8	1.6 ~ 2.0	35.7

NOTE: Sourcing current out of the CV is typically 50 μA .

REVISION HISTORY

NOTE: Page numbers for previous revisions may differ from page numbers in the current version.

SEPTEMBER 2022 – REV.A to REV.A.1

Page

Updated Electrical Characteristics section 5, 6

Changes from Original (AUGUST 2022) to REV.A

Page

Changed from product preview to production data..... All

PACKAGE OUTLINE DIMENSIONS

TDFN-3x3-12L

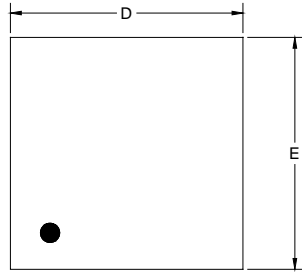

TOP VIEW

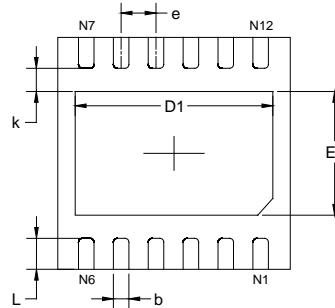

BOTTOM VIEW



SIDE VIEW

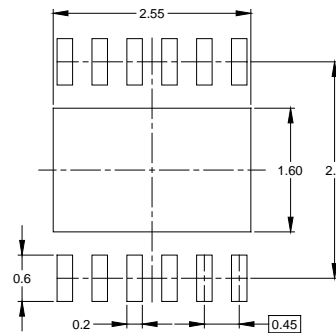

RECOMMENDED LAND PATTERN (Unit: mm)

Symbol	Dimensions In Millimeters		Dimensions In Inches	
	MIN	MAX	MIN	MAX
A	0.700	0.800	0.028	0.031
A1	0.000	0.050	0.000	0.002
A2	0.203 REF		0.008 REF	
D	2.924	3.076	0.115	0.121
D1	2.450	2.650	0.096	0.104
E	2.924	3.076	0.115	0.121
E1	1.500	1.700	0.059	0.067
k	0.200 MIN		0.008 MIN	
b	0.150	0.250	0.006	0.010
e	0.450 TYP		0.018 TYP	
L	0.324	0.476	0.013	0.019

NOTE: This drawing is subject to change without notice.

PACKAGE INFORMATION

TAPE AND REEL INFORMATION

REEL DIMENSIONS



TAPE DIMENSIONS



NOTE: The picture is only for reference. Please make the object as the standard.

KEY PARAMETER LIST OF TAPE AND REEL

Package Type	Reel Diameter	Reel Width W1 (mm)	A0 (mm)	B0 (mm)	K0 (mm)	P0 (mm)	P1 (mm)	P2 (mm)	W (mm)	Pin1 Quadrant
TDFN-3×3-12L	13"	12.4	3.30	3.30	1.10	4.0	8.0	2.0	12.0	Q1

000001

PACKAGE INFORMATION

CARTON BOX DIMENSIONS



NOTE: The picture is only for reference. Please make the object as the standard.

KEY PARAMETER LIST OF CARTON BOX

Reel Type	Length (mm)	Width (mm)	Height (mm)	Pizza/Carton
13"	386	280	370	5

DD0002