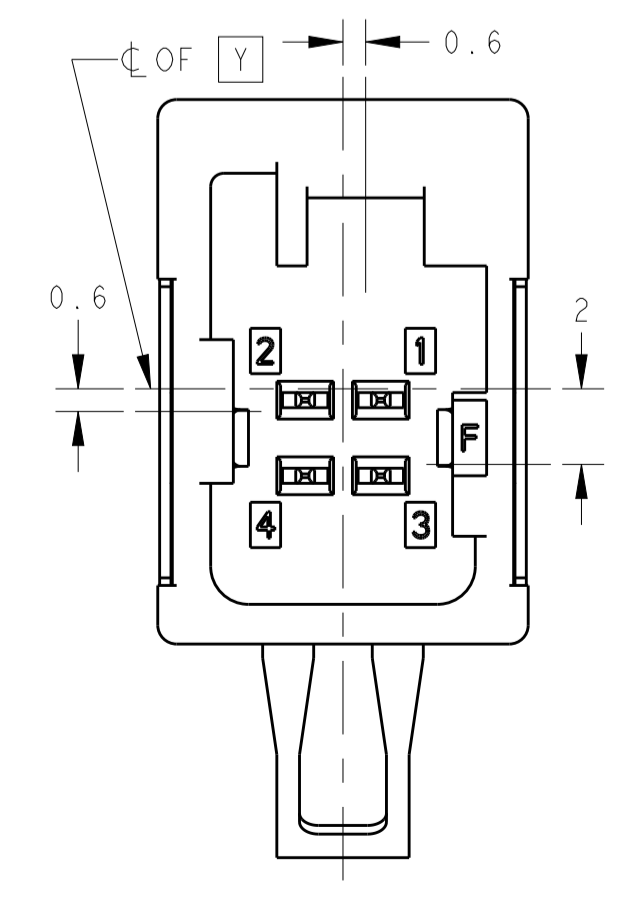
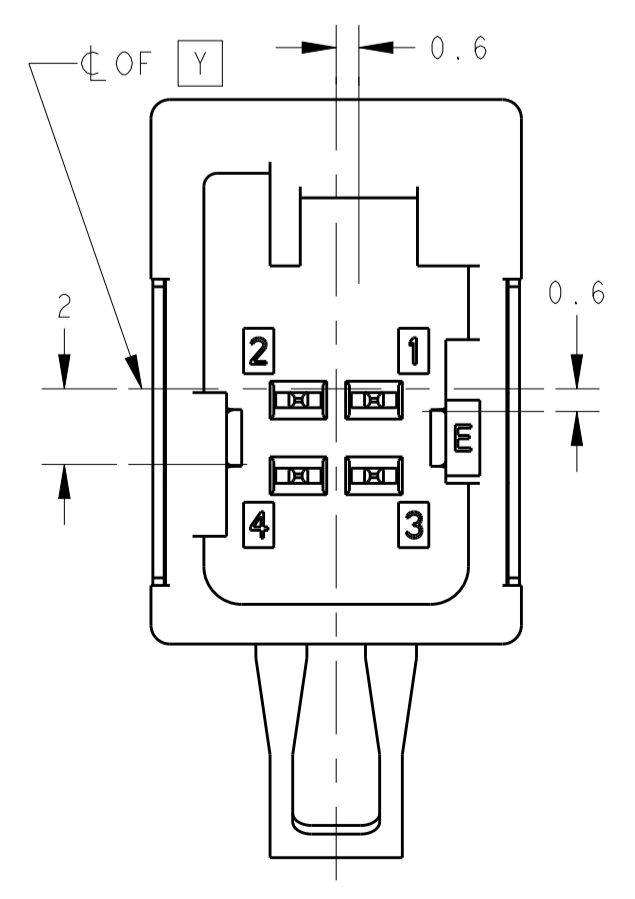

TABLE 2 KEY VARIATIONS



KEY F  
2174512-6



KEY E  
2174512-5

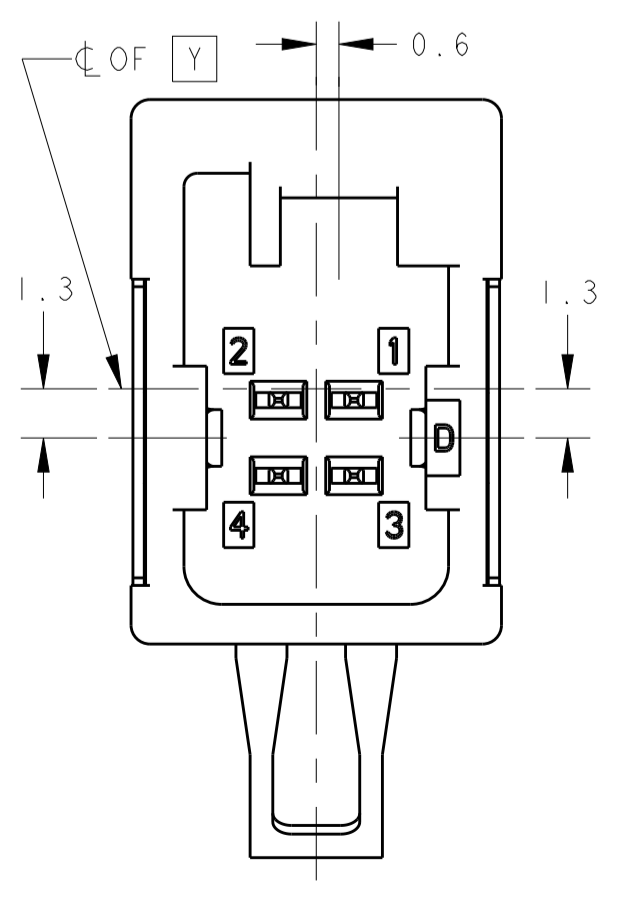

KEY D  
2174512-4

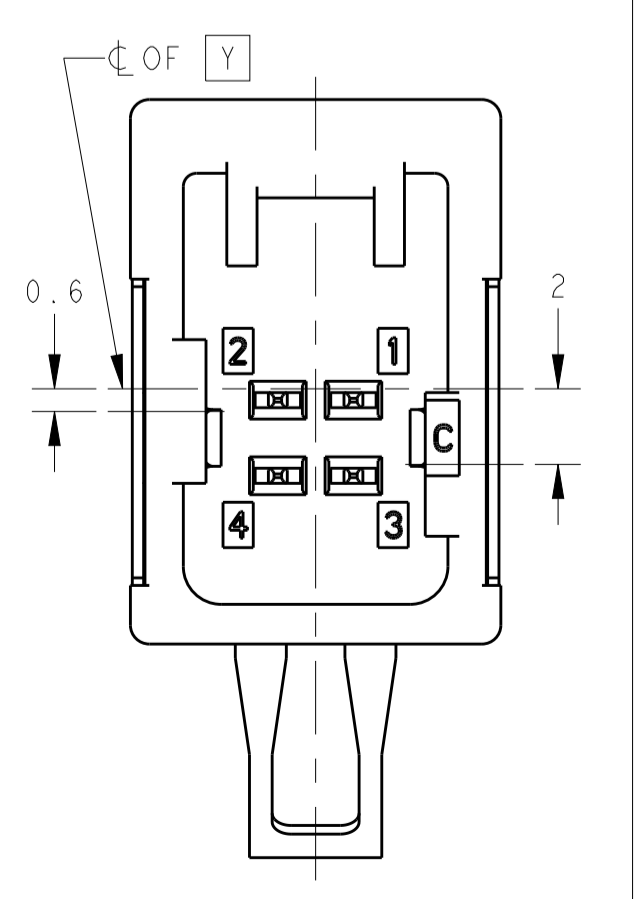

KEY C  
2174512-3

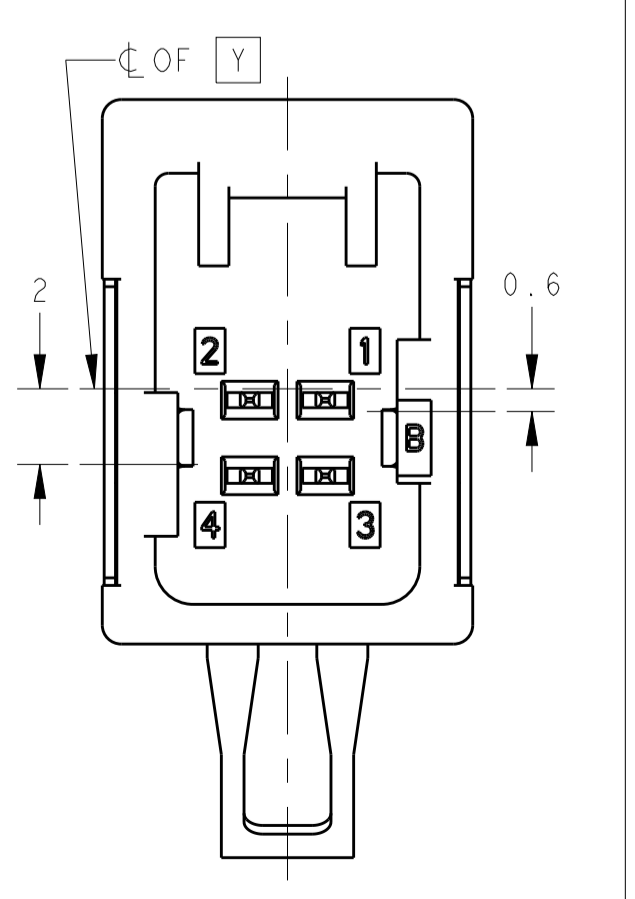

KEY B  
2174512-2

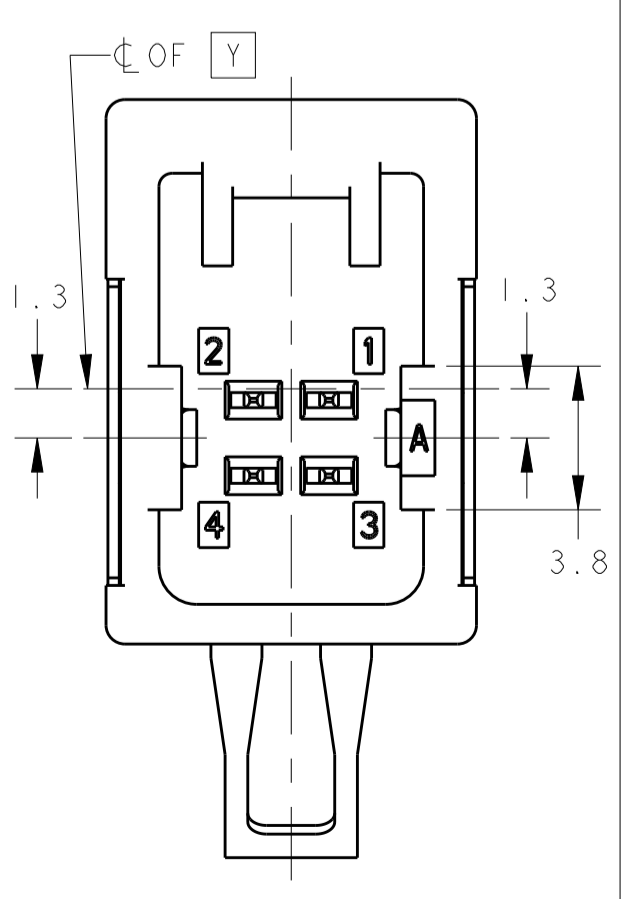

KEY A  
2174512-1

KEY TYPE  
PART NO.

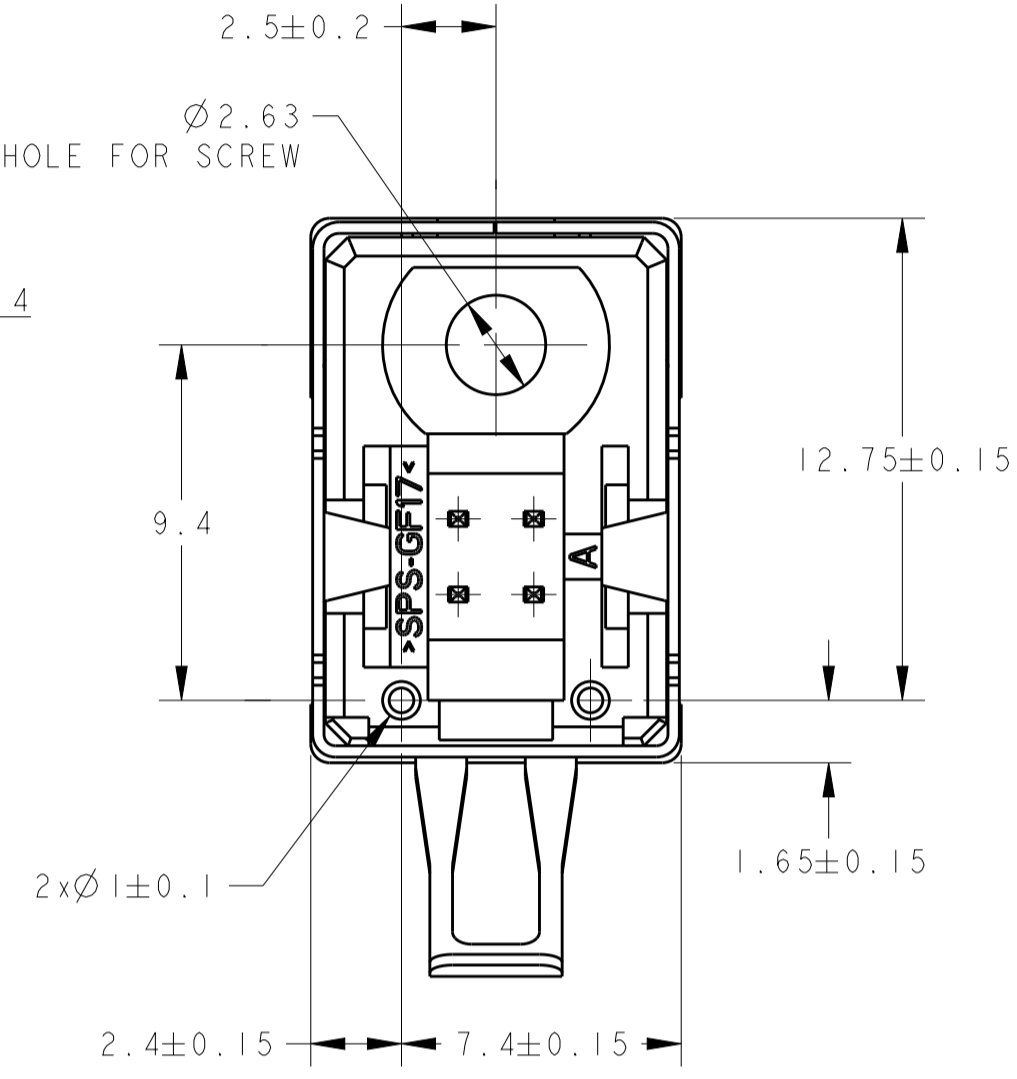
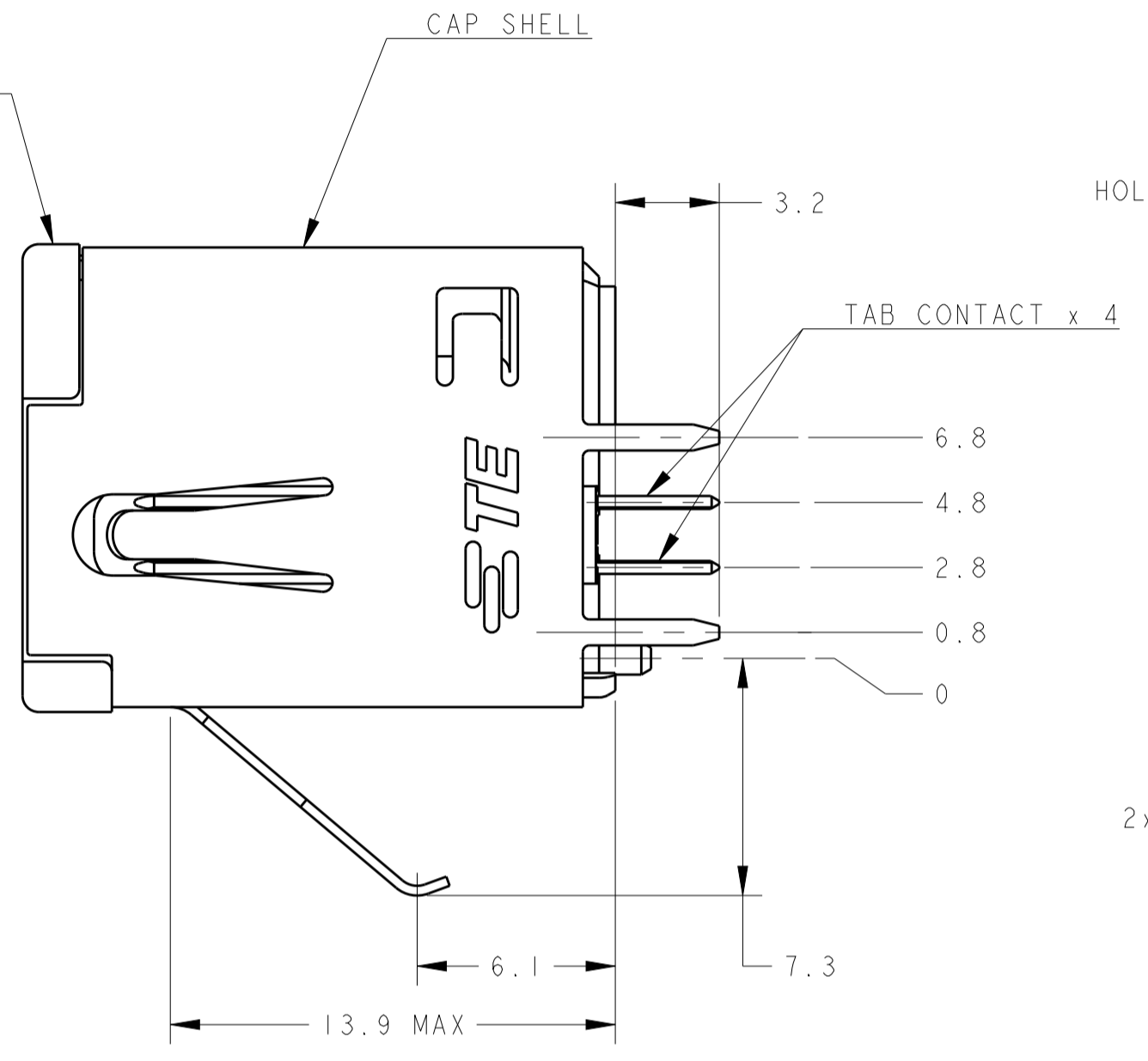
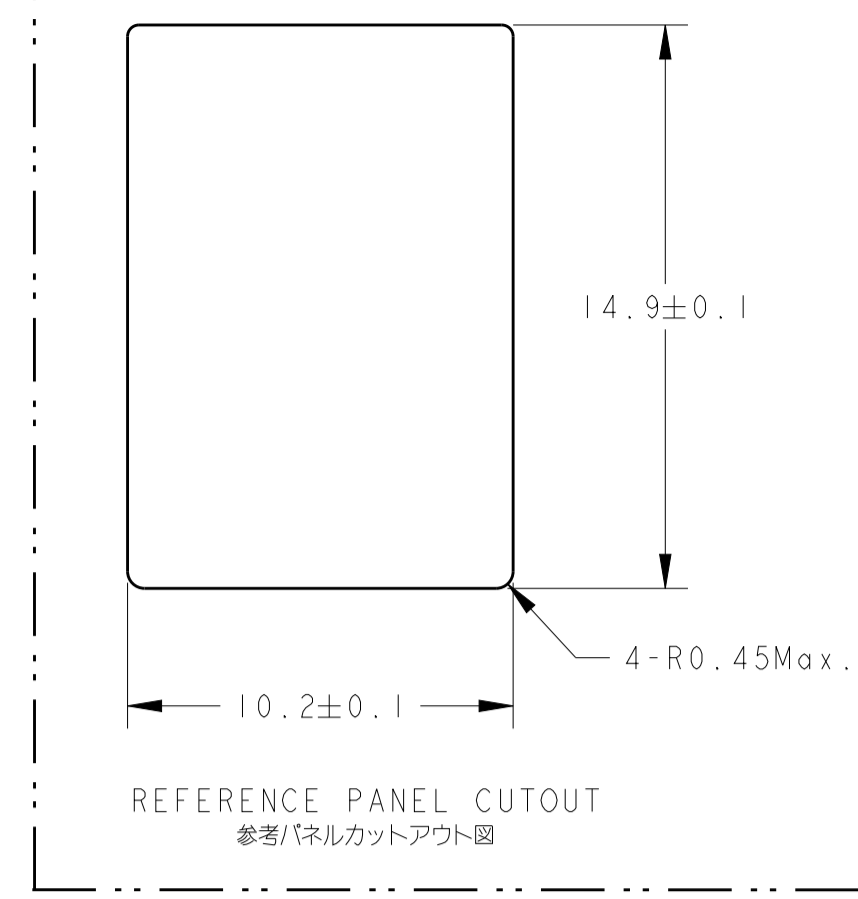
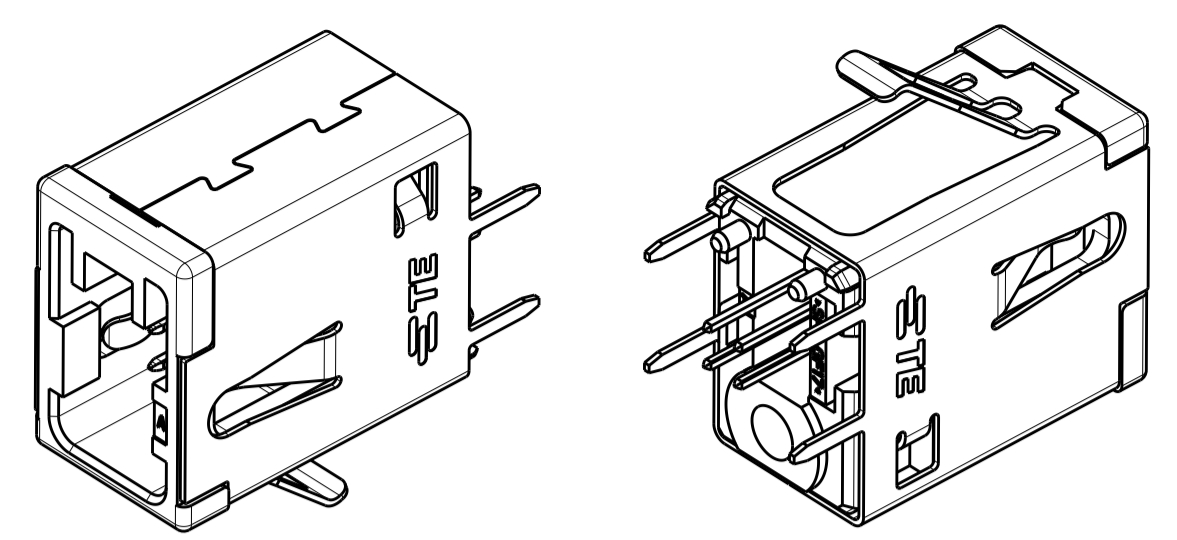

TABLE 1

THICKNESS OF PCB(mm) プリント基板板厚 (mm)	1.2	1.6
NOMINAL LENGTH OF SCREW(mm) 固定用ねじ首下長さ (mm)	5	6

- △. RECOMMENDED SCREW: PAN-HEADED, TYPE 2 TAPPING SCREW (JIS B1115, B1122)  
NOMINAL DIAMETER: 3  
SCREW LENGTH: SEE TABLE 1
  - △. THIS PRODUCT HAS KEY VARIATIONS. SEE TABLE 2.
  - 3. FASTENING TORQUE FOR SCREW (FOR REFERENCE): 0.392 N·m MAX.
  - 4. THE PRODUCT THAT WAS DROPPED FROM THE PACKAGE OR THE PRODUCT THAT SHELL SPRING WAS DEFORMED MUST NOT BE USED.
  - 5. PLUG COMPONENTS TO BE MATED: SEE INSTRUCTION SHEET 408-78007.
- △. 推奨取付ねじ: JIS B1115 B1122タッピングねじ  
なべ2種 呼び径3、長さTABLE 1による。
- △. 本製品はキーバリエーションが存在する。  
形状はTABLE 2を参照のこと。
3. ねじ締めトルク(参考値): 0.392 N·m MAX  
4. 梱包から落ちたコネクタおよびSHELLのねじを变形させずコネクタは使用しないこと。  
5. 嵌合相手のプラグコンポーネントについては、取扱説明書 408-78007を参照のこと。

REVISIONS

LOC	DIST	REV	DATE	APPD
J	-	A	06NOV2012	TK KO

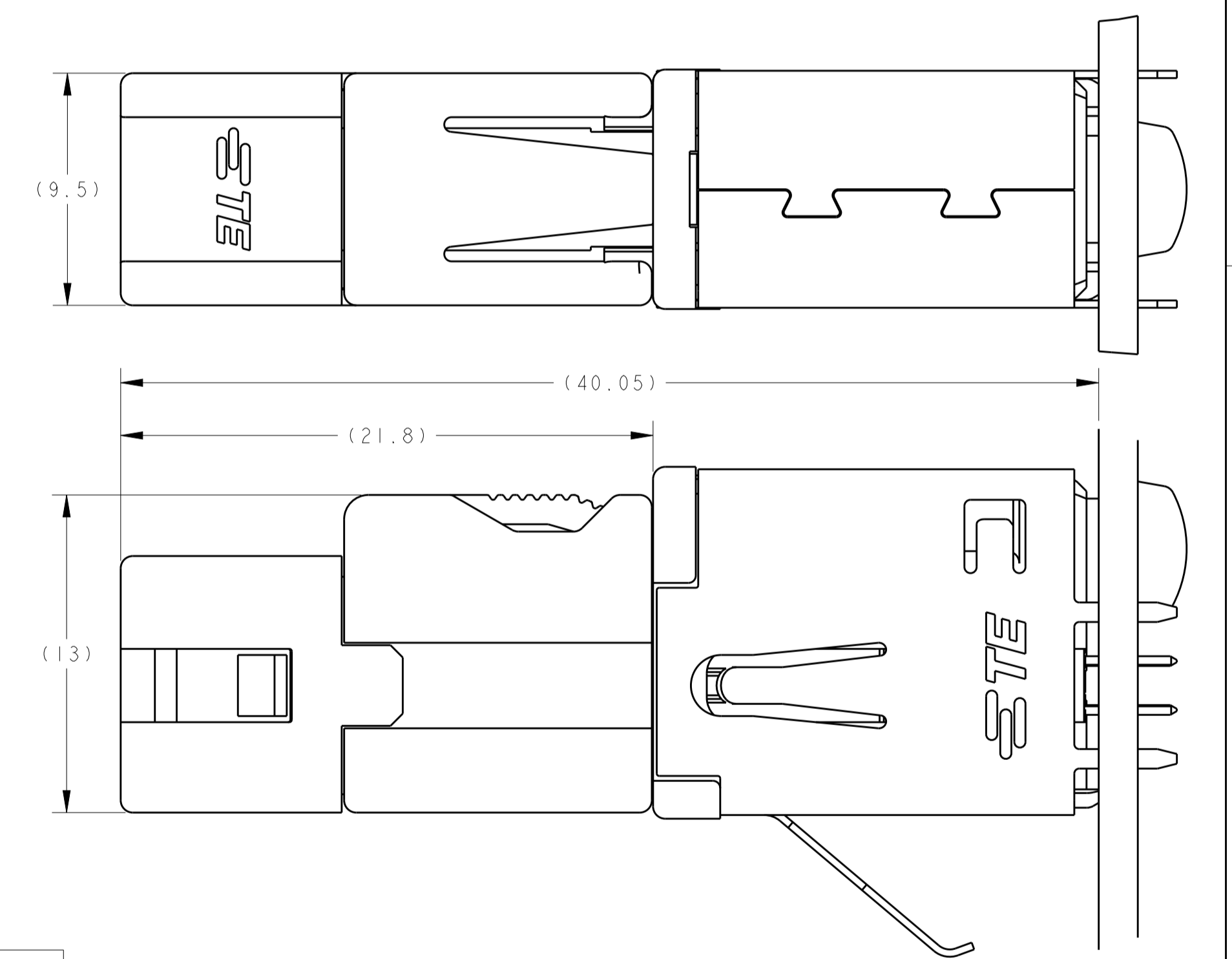
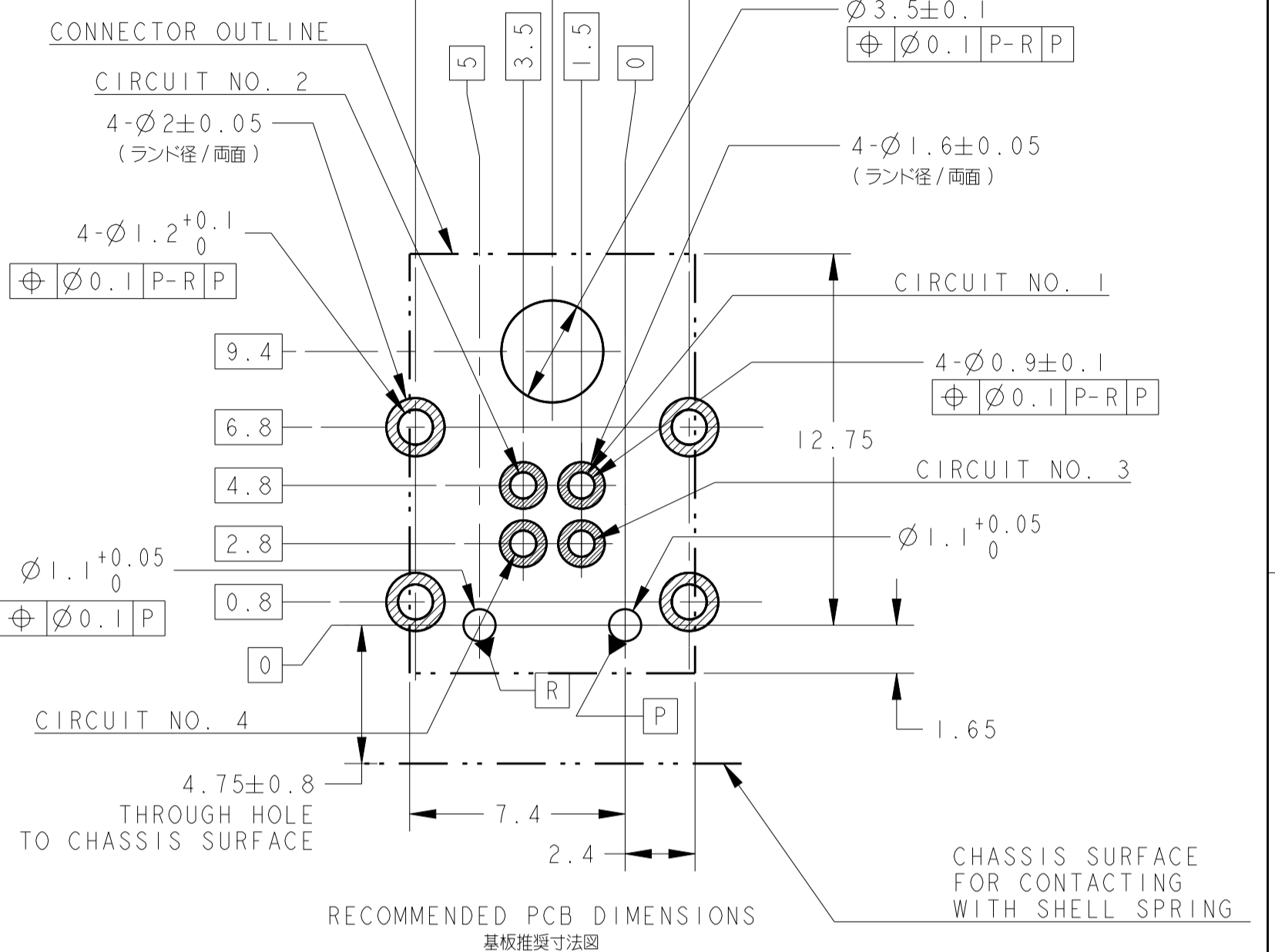

PRE-TIN 前線めっき	COPPER ALLOY 銅合金	POST-TIN 後線めっき	BRASS 黄銅	SPS	GREEN 緑	KEY F	2174512-6
PRE-TIN 前線めっき	COPPER ALLOY 銅合金	POST-TIN 後線めっき	BRASS 黄銅	SPS	BLUE 青	KEY E	2174512-5
PRE-TIN 前線めっき	COPPER ALLOY 銅合金	POST-TIN 後線めっき	BRASS 黄銅	SPS	BROWN 茶	KEY D	2174512-4
PRE-TIN 前線めっき	COPPER ALLOY 銅合金	POST-TIN 後線めっき	BRASS 黄銅	SPS	NATURAL 自然色	KEY C	2174512-3
PRE-TIN 前線めっき	COPPER ALLOY 銅合金	POST-TIN 後線めっき	BRASS 黄銅	SPS	GRAY 灰色	KEY B	2174512-2
PRE-TIN 前線めっき	COPPER ALLOY 銅合金	POST-TIN 後線めっき	BRASS 黄銅	SPS	BLACK 黒	KEY A	2174512-1
FINISH 仕上げ	MATERIAL 材料	FINISH 仕上げ	MATERIAL 材料	MATERIAL 材料	COLOR 色	KEY TYPE	PART NO.
CAP SHELL キャップ シェル	TAB CONTACT タブ コンタクト	CAP HOUSING キャップ ハウジング					

THIS DRAWING IS A CONTROLLED DOCUMENT. DWN T. KUMAMOTO 06NOV2012  
 DIMENSIONS: mm TOLERANCES UNLESS OTHERWISE SPECIFIED: 0-PLC ±0.3 1-PLC ±0.5 2-PLC ±0.3 3-PLC ±0.13 4-PLC ±0.001 ANGLES ±1

OTHERWISE SPECIFIED: K. ODA 06NOV2012  
 PRODUCT SPEC 108-78895  
 APPLICATION SPEC

NAME: CAP ASSEMBLY 4 POS. VERTICAL 0.50 HSL CONNECTOR  
 SIZE: CAGE CODE DRAWING NO. RESTRICTED TO A1  
 WEIGHT: 3.9 g  
 CUSTOMER DRAWING SCALE: 5:1 SHEET 1 OF 1 REV A

TE Connectivity