

LOC	DIST	REVISIONS			
P	LTH	DESCRIPTION	DATE	DWN	APVD
A	RELEASED		15JAN13	JY	JY

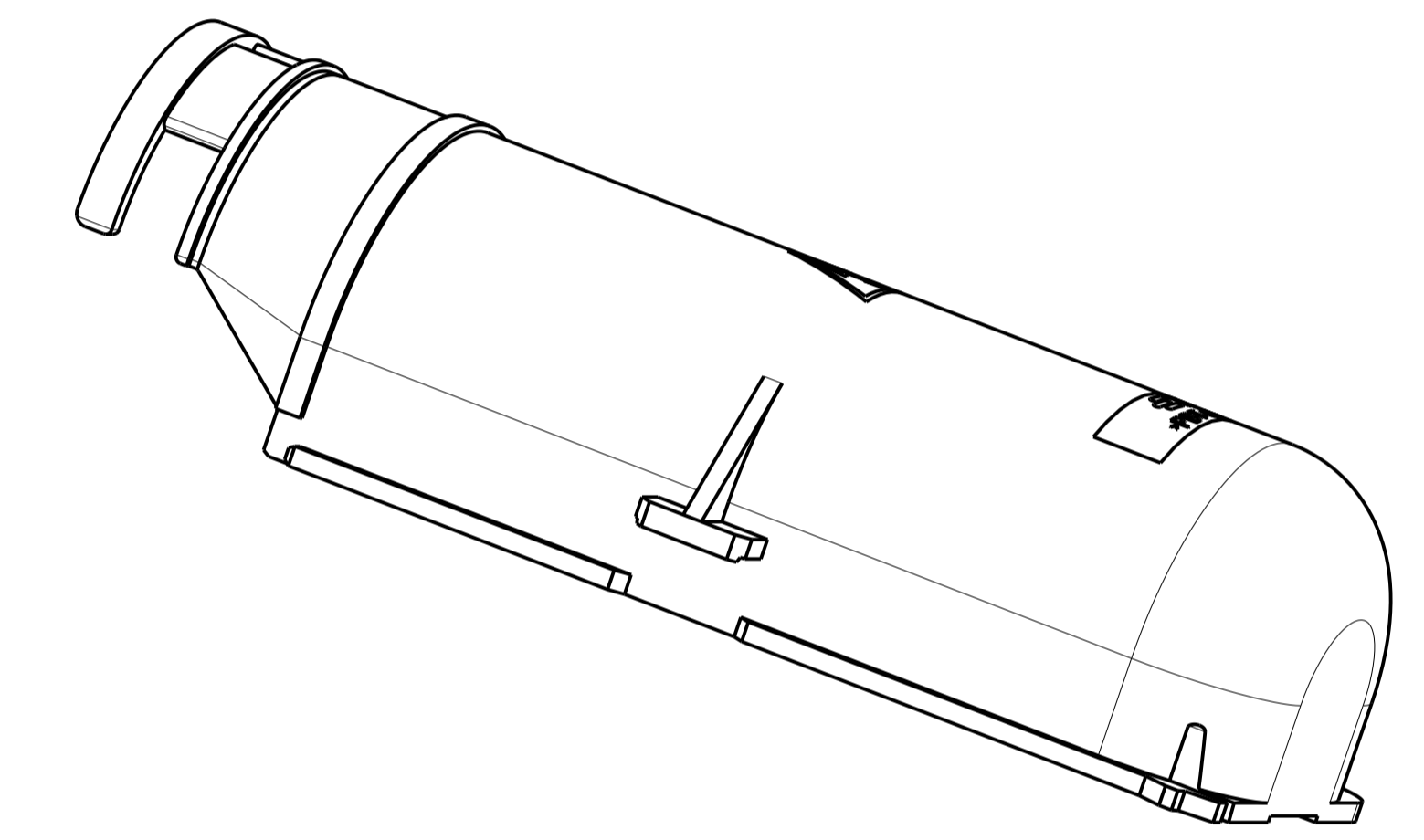

NOTES

- 1 CHARACTERS ACC. TO DIN 1451-HI.5, CHARACTERS 0.15 RAISED
- 2 EXCHANGEABLE
- 3 CAVITY MARKING:
- 4 MATERIAL MARKING ACC. TO VDA 260
- 5 MANUFACTURE DATE Ø4, RECEDE
- 6 LETTER INSERT FOR THE REVISION STATUS OF THE MOULD
ACTUAL STATUS SEE TABLE
- 7 EXTERNAL SURFACE ACC. TO VDI 3400/27
- 8 LOGO 1621426-6, ACC.TE SPEC TEC-202-36
- 9 TE P/N
- 10 SIGN ACC. TO DIN 40008 WS 1, RECEDE

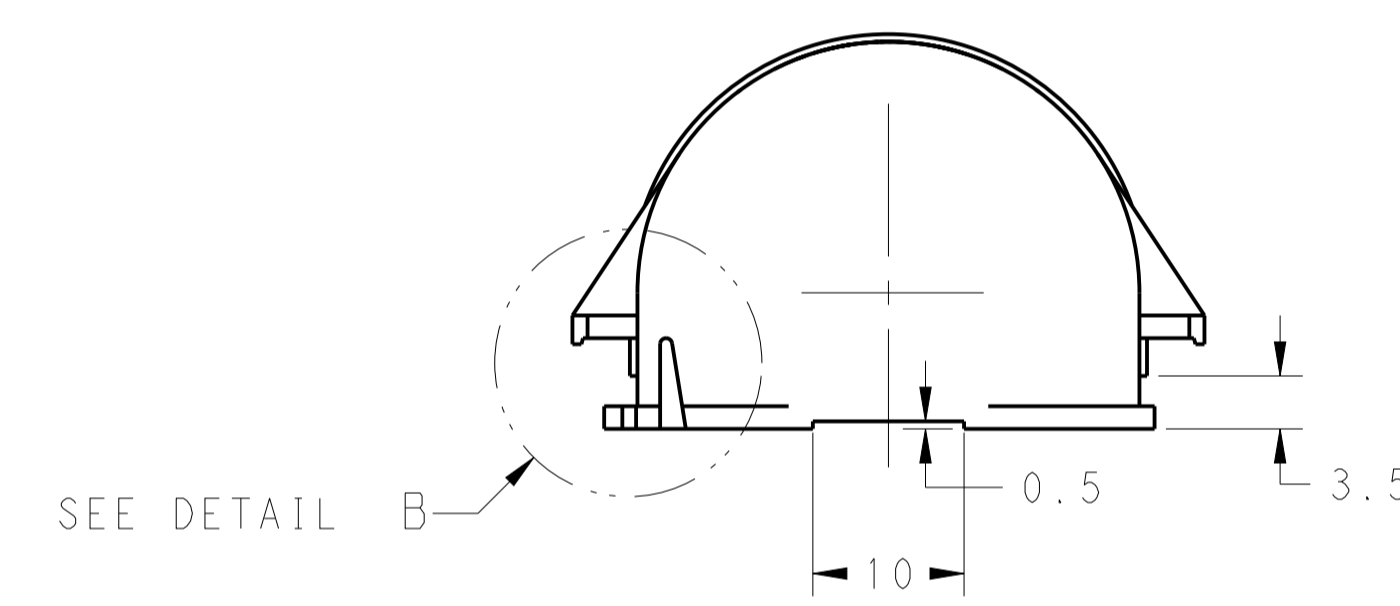
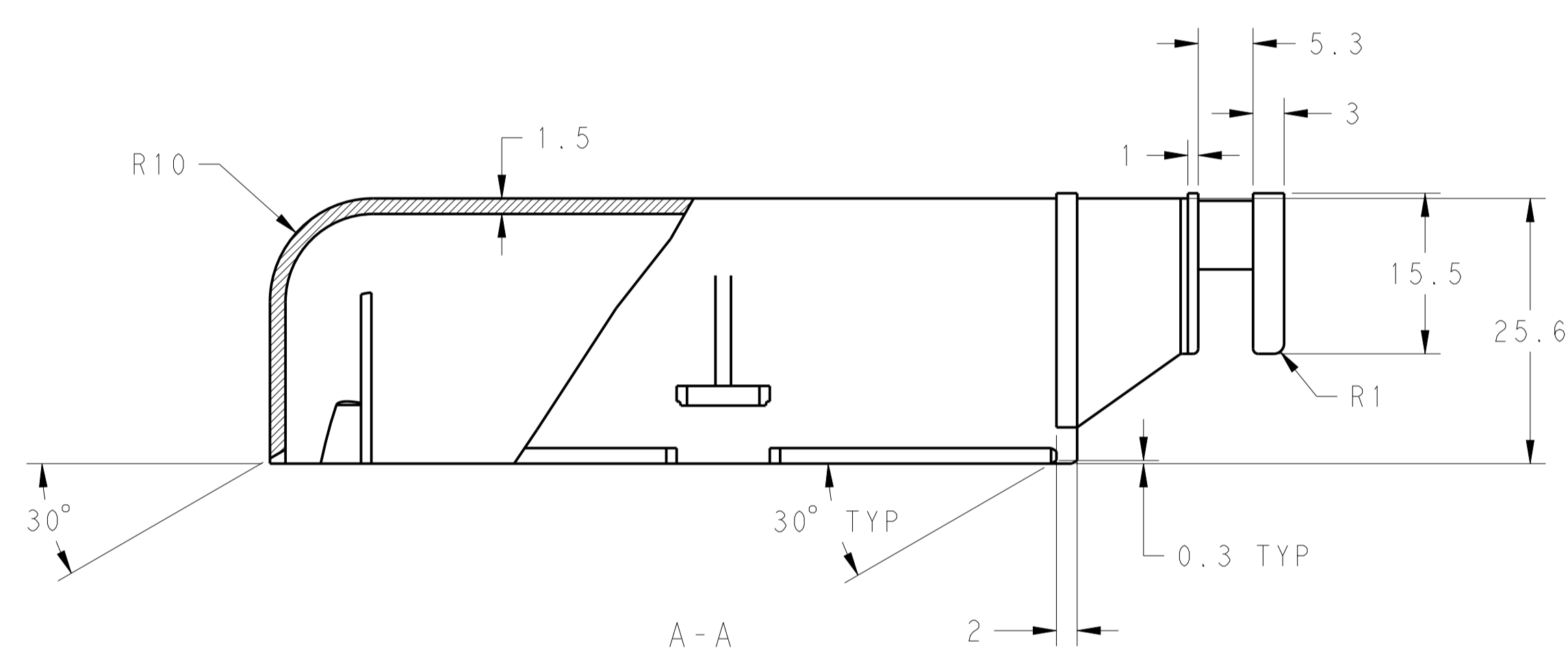
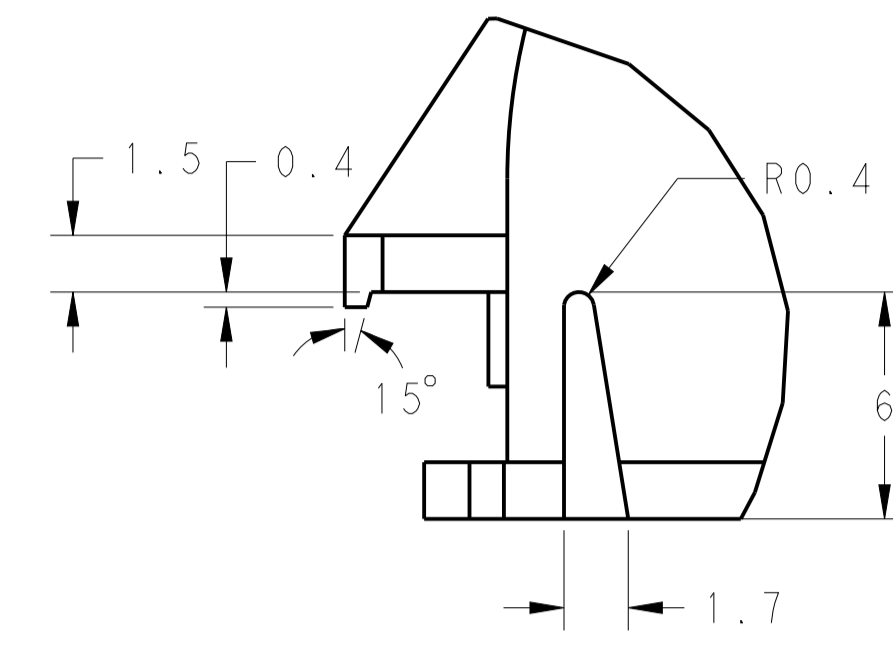
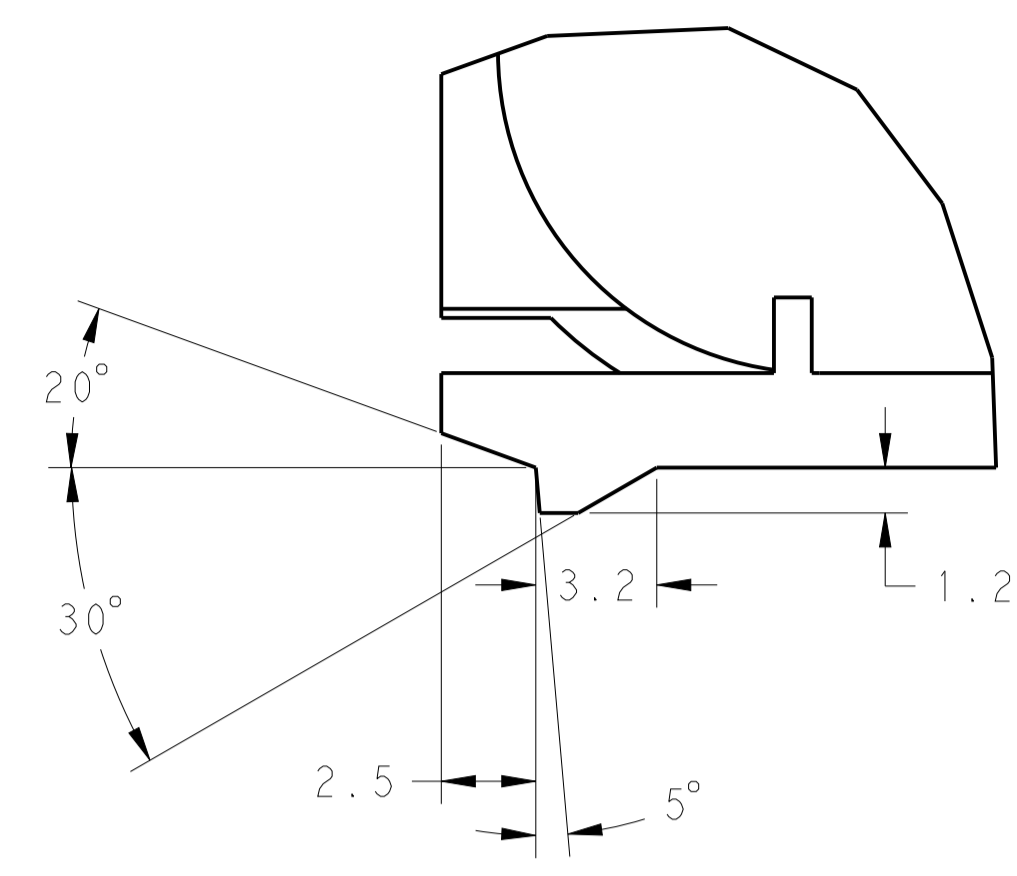
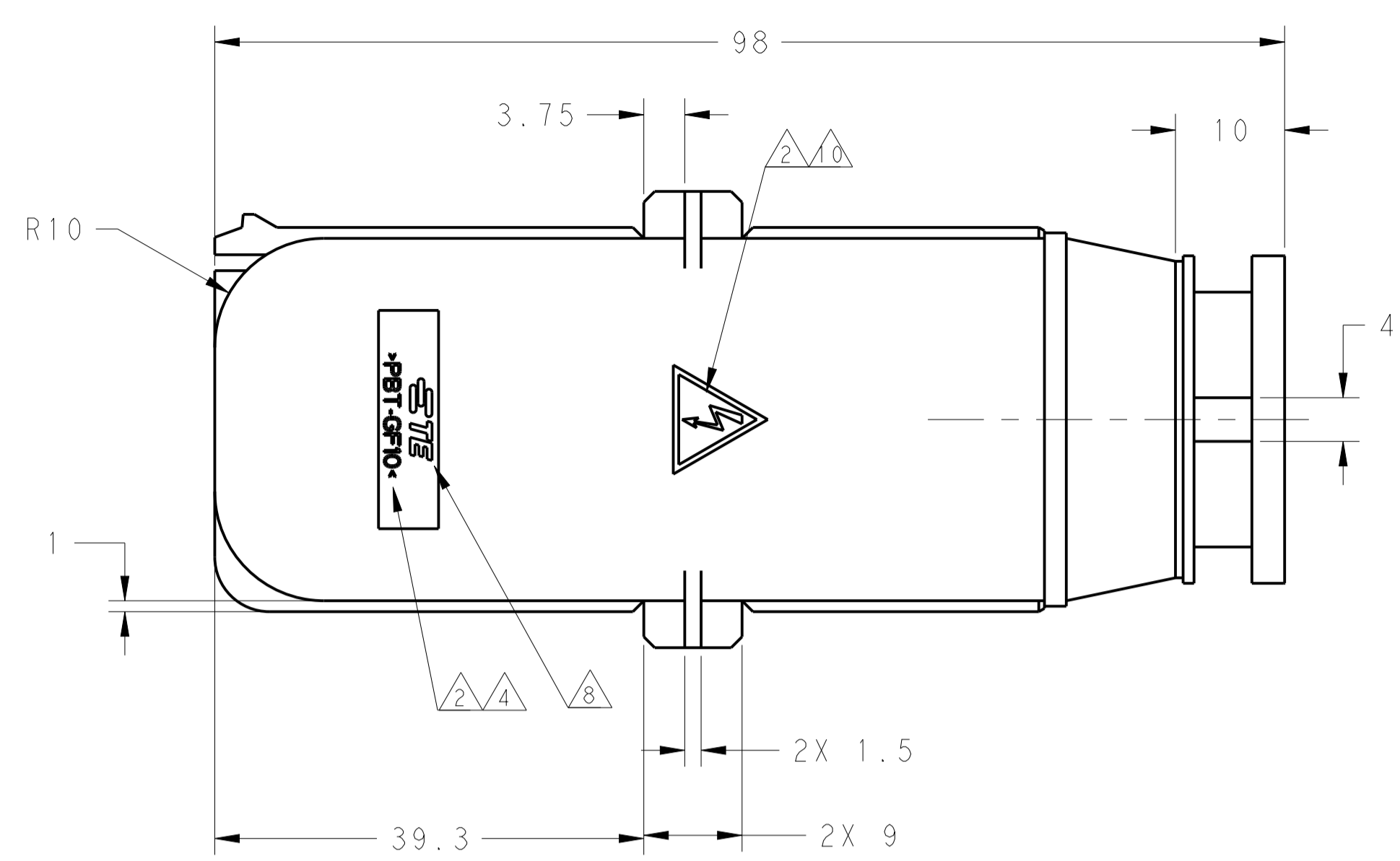
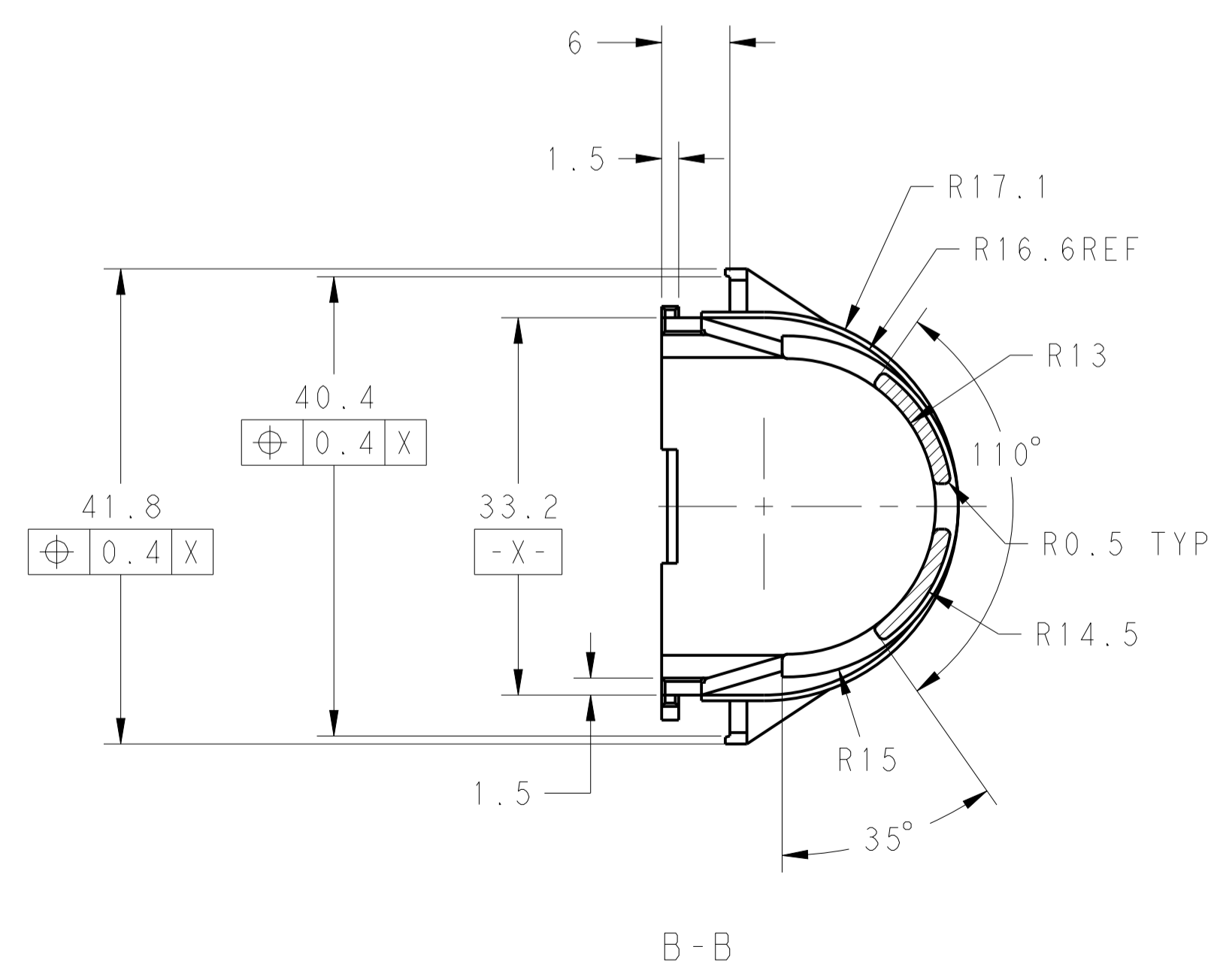
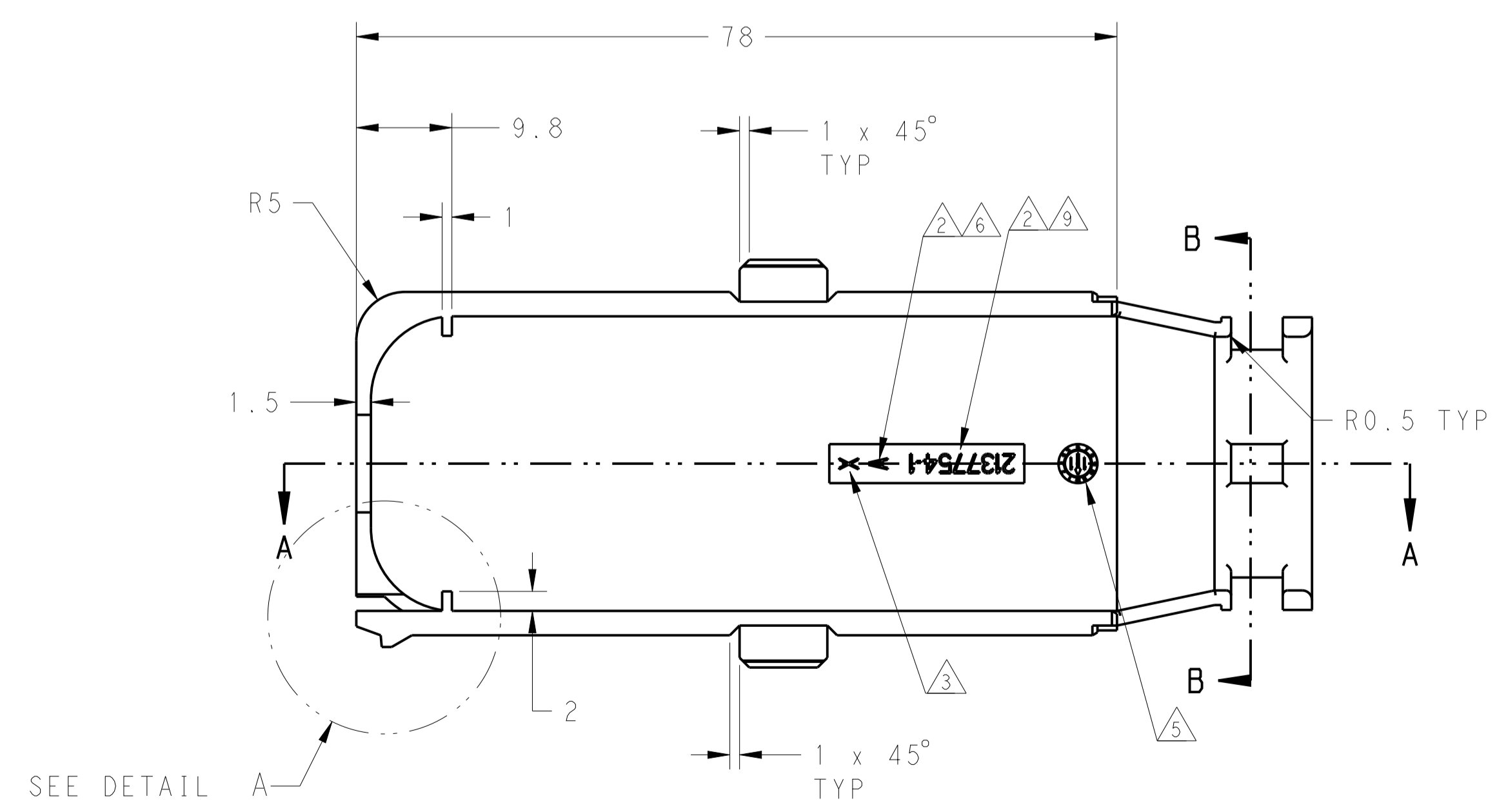

2137754-1	A	BLAC	PBT-GF10	I
PART NO.	PART REV.	COLOR	MATERIAL	ITEM
DWN J. YU 22JUL11		TE Connectivity		
CHK W. YUAN 10AUG11		NAME 94P COVER FOR RECEPTABLE HSG 154P ECU CONNECTOR		
APVD W. YUAN 10AUG11		SIZE CAGE CODE DRAWING NO RESTRICTED TO		
MATERIAL		A100779C=2137754		
Customer Drawing		SCALE 2:1 SHEET 1 OF 1 REV A		