

REVISIONS				
P	LTM	DESCRIPTION	DATE	APVD
A		RELEASED	-	HX -
B		REVISED ECR-17-018365	31OCT2017	Z.L I.Y

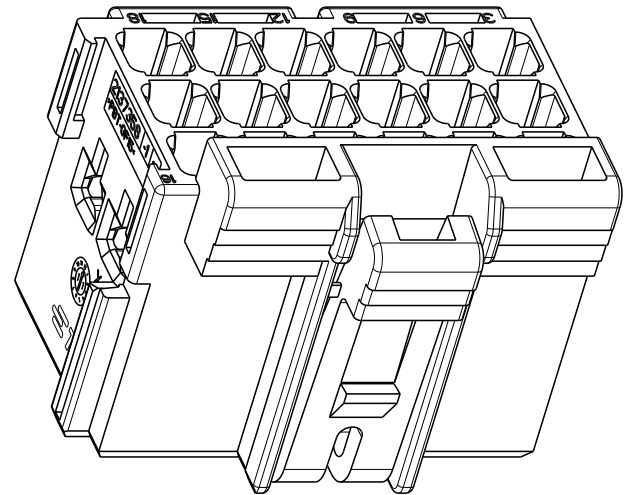

SCALE 2:1

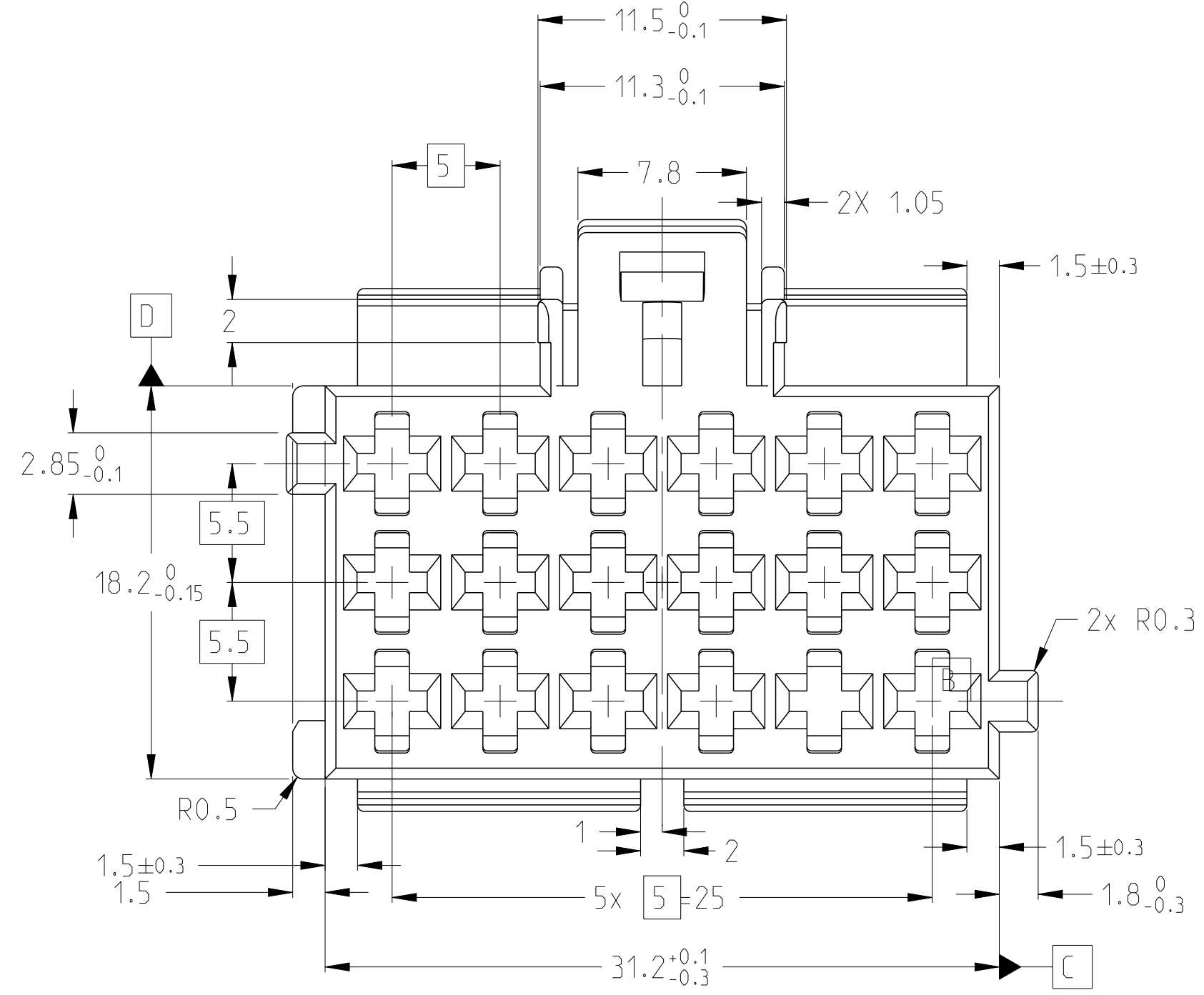
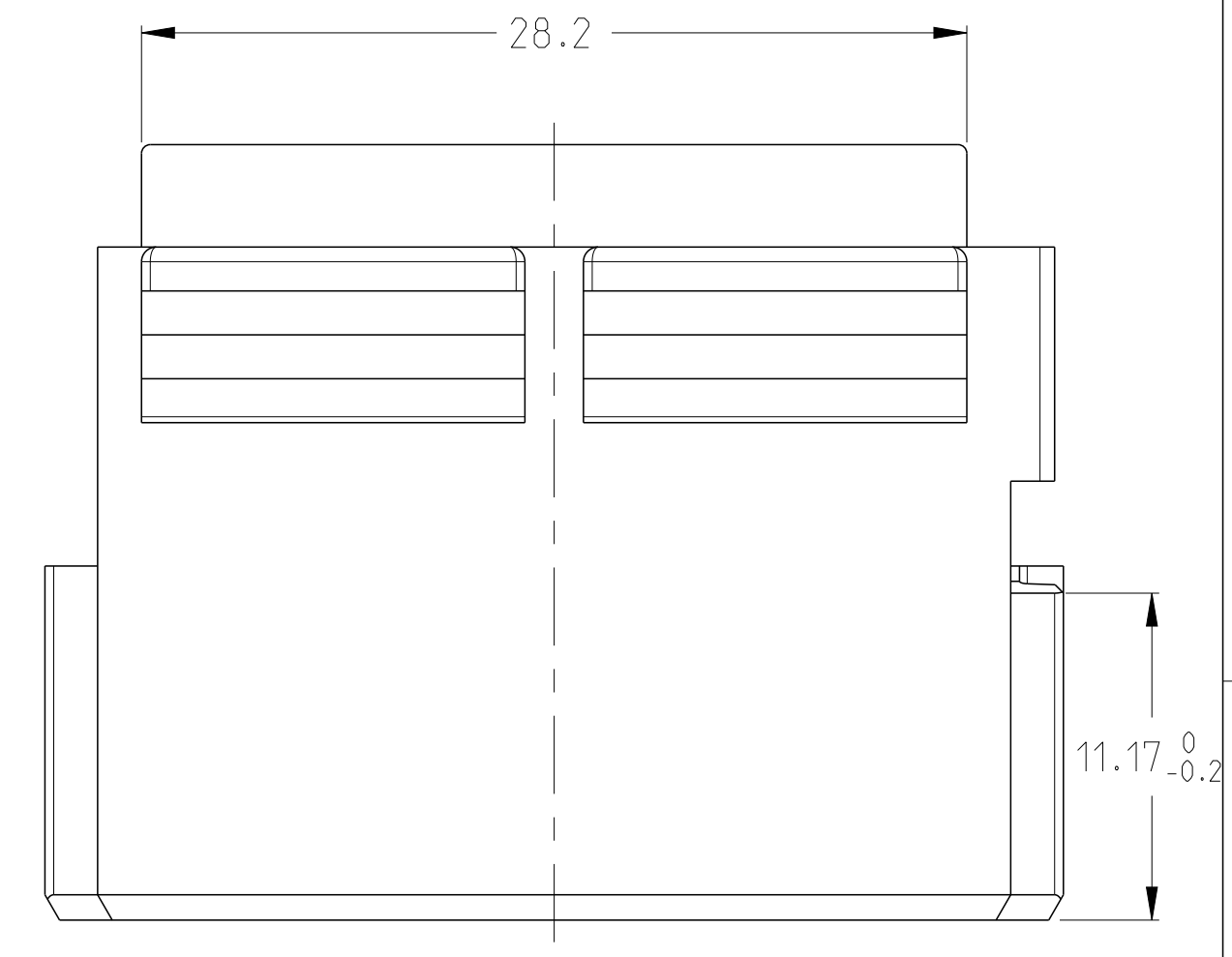
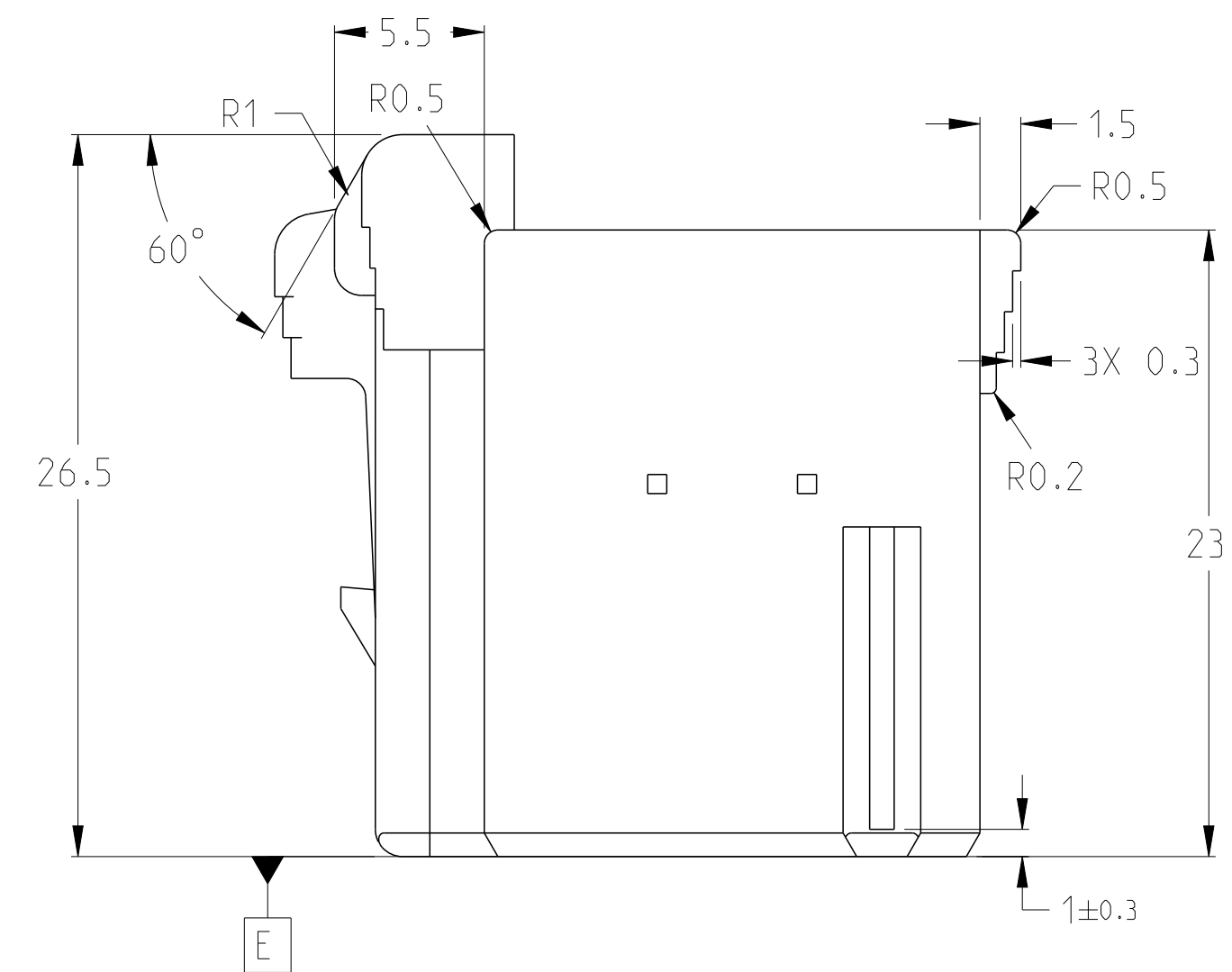
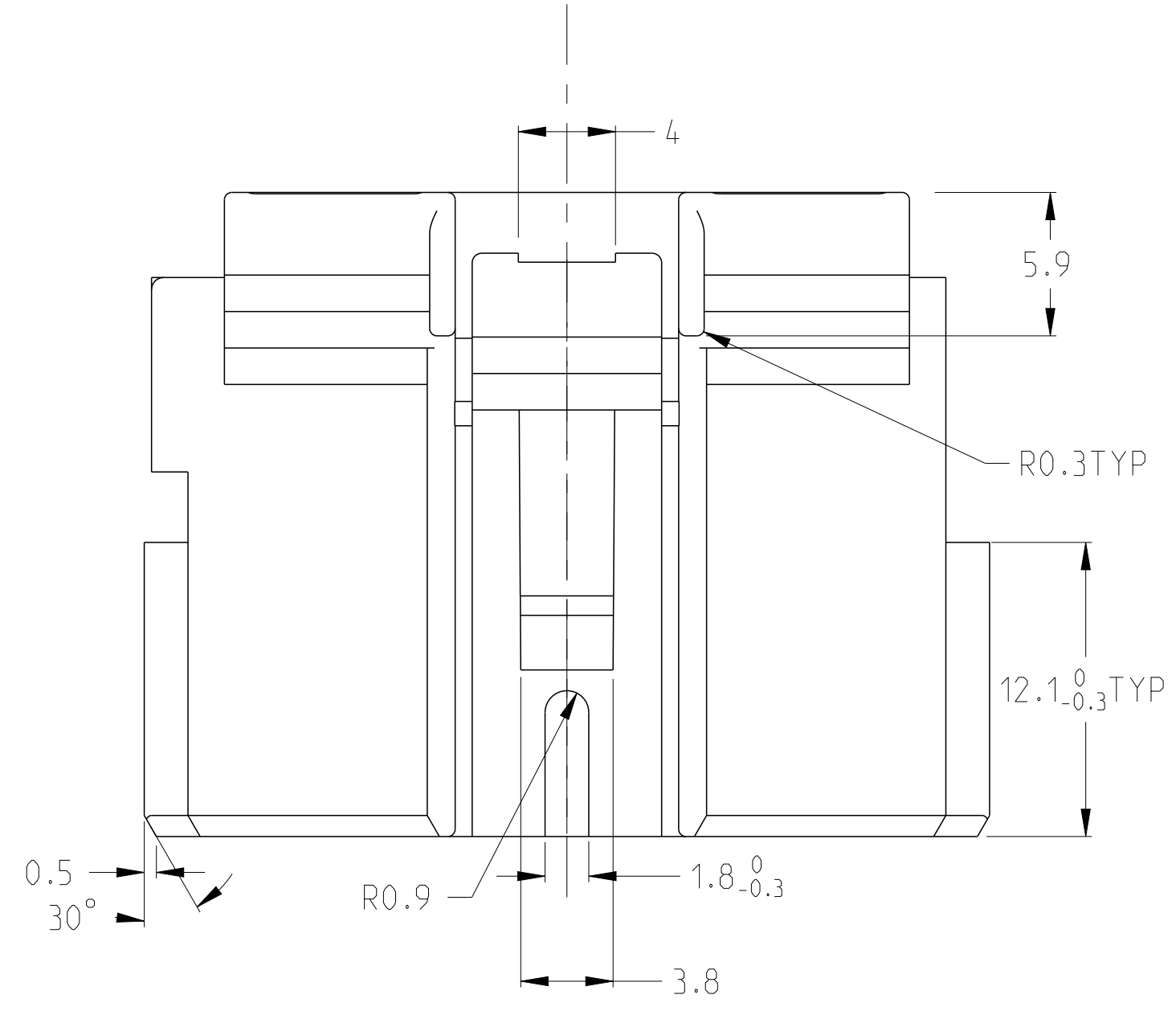
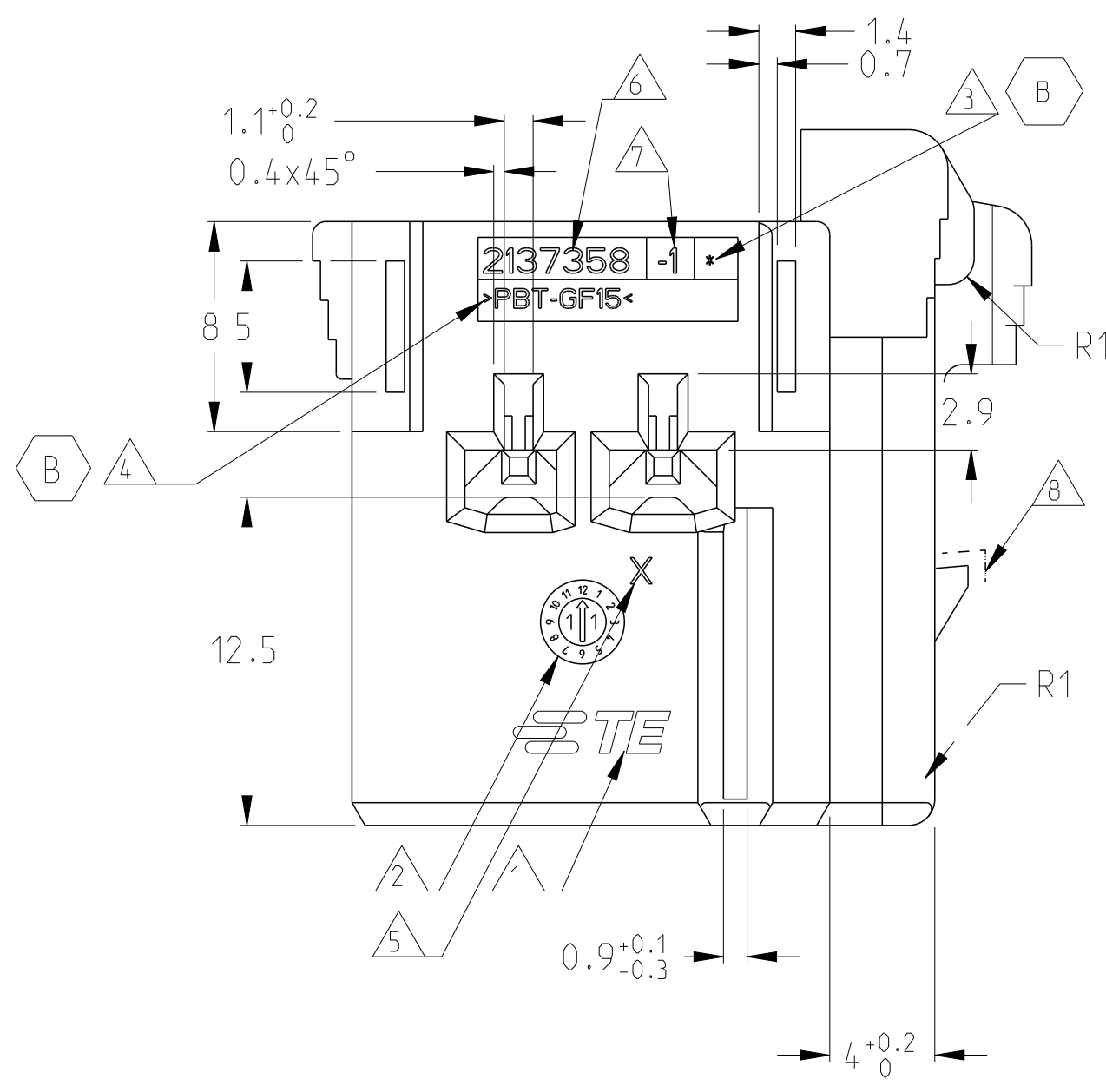
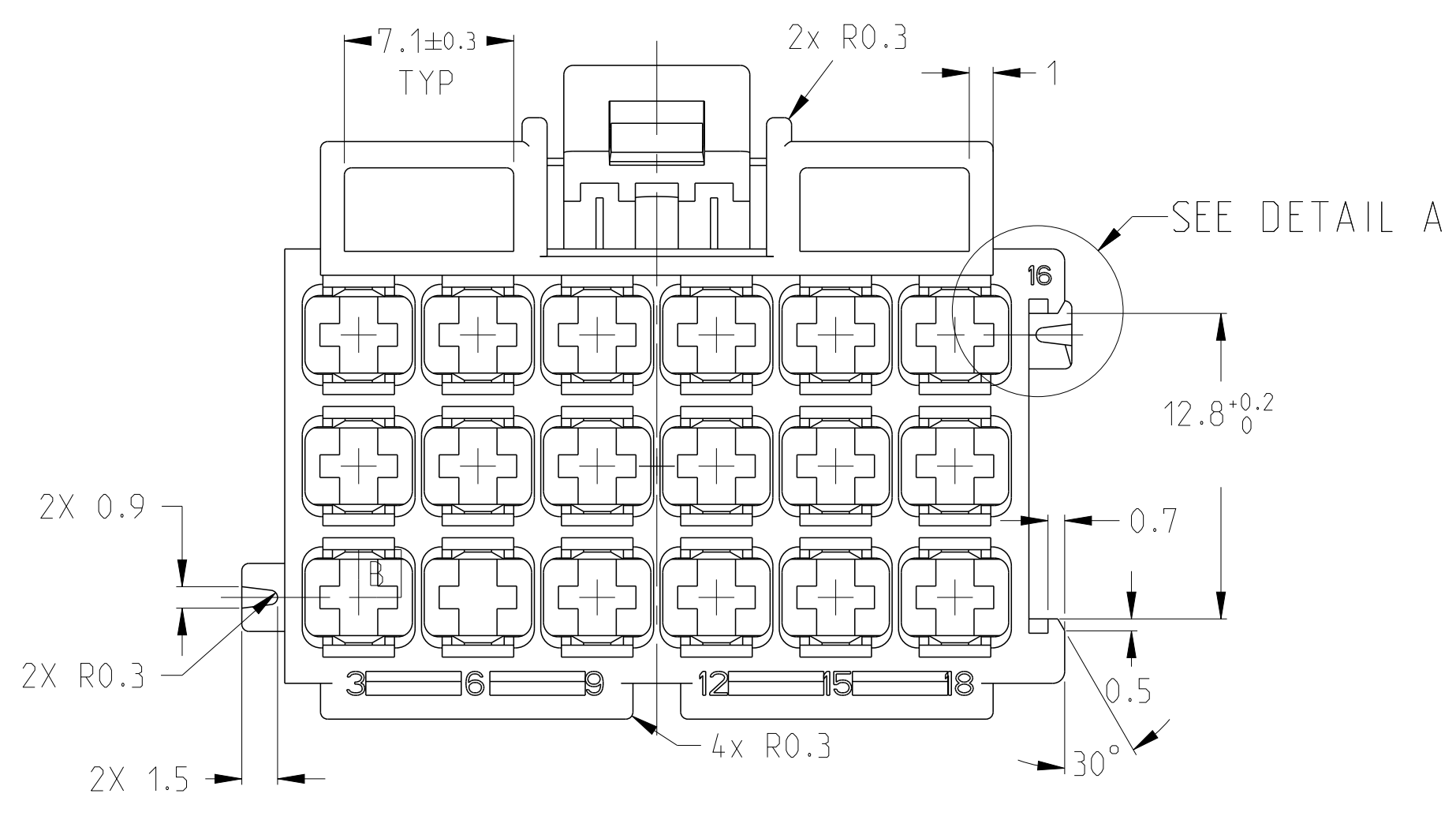

THIS DRAWING IS A CONTROLLED DOCUMENT.		OWN: H.XU 04SEPT12	TE Connectivity NAME: AMP-MCP 2.8mm RECEPTACLE HOUSING .18POS
DIMENSIONS: mm		CHK: Z.ZHOU 15NOV12	
TOLERANCES UNLESS OTHERWISE SPECIFIED:		APVD: W.YUAN 15NOV12	SIZE: -
0-PLC ±.015 1-PLC ±.015 2-PLC ±.015 3-PLC ±.015 4-PLC ±.015 ANGLES ±0°		PRODUCT SPEC: 108-101234	RESTRICTED TO: -
MATERIAL: PBT-GF15 1573359-4		APPLICATION SPEC: 116-101014	SCALE: 4:1
WEIGHT: 9.516g		116-101014	SHEET 1 OF 2
CUSTOMER DRAWING		00779	REV B

REVISIONS				
P	LTN	DESCRIPTION	DATE	APVD
-	-	SEE SHEET 1	-	-

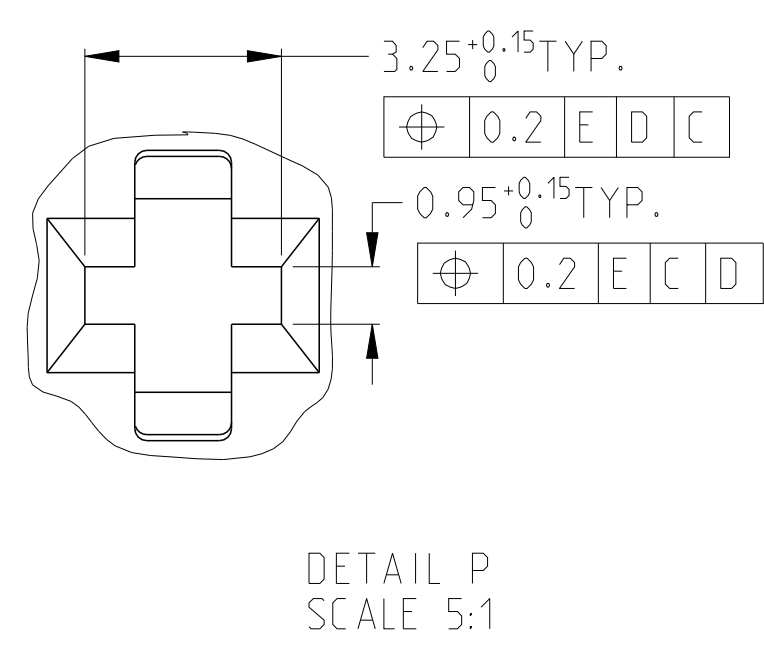
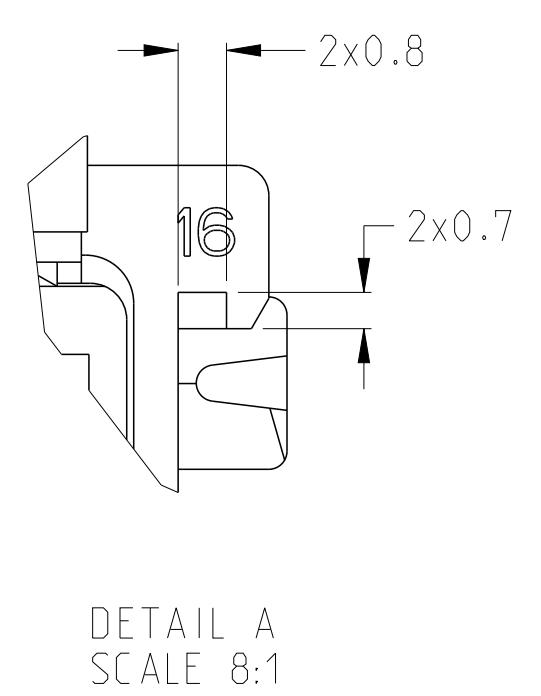
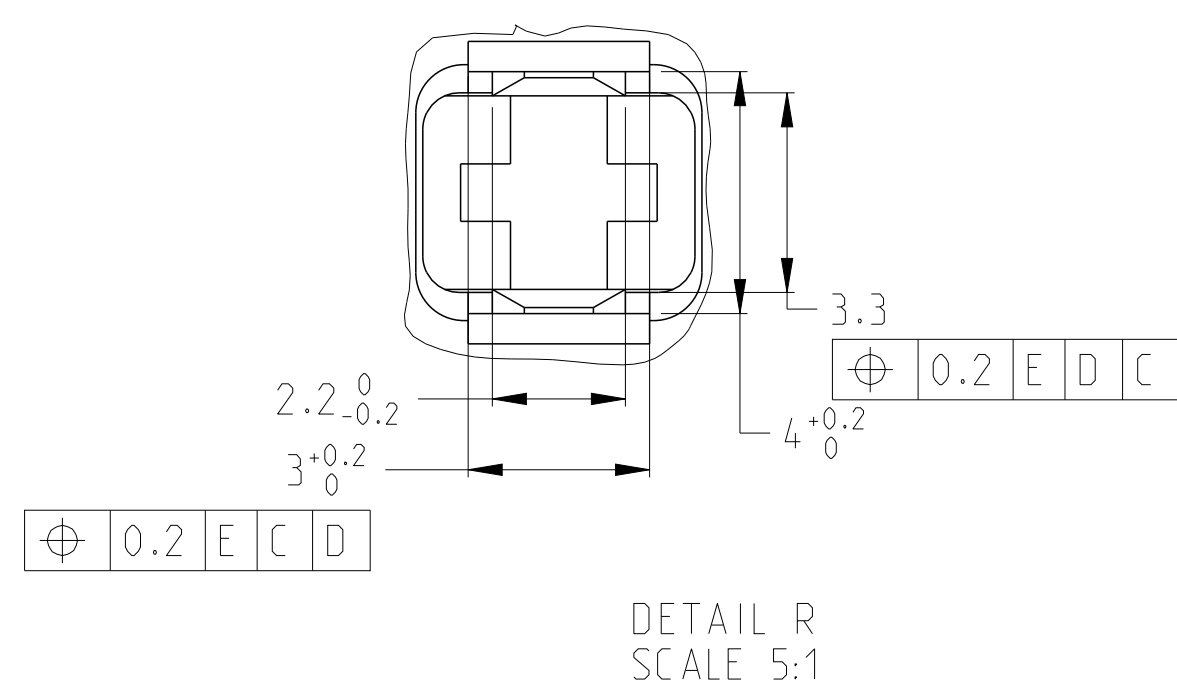
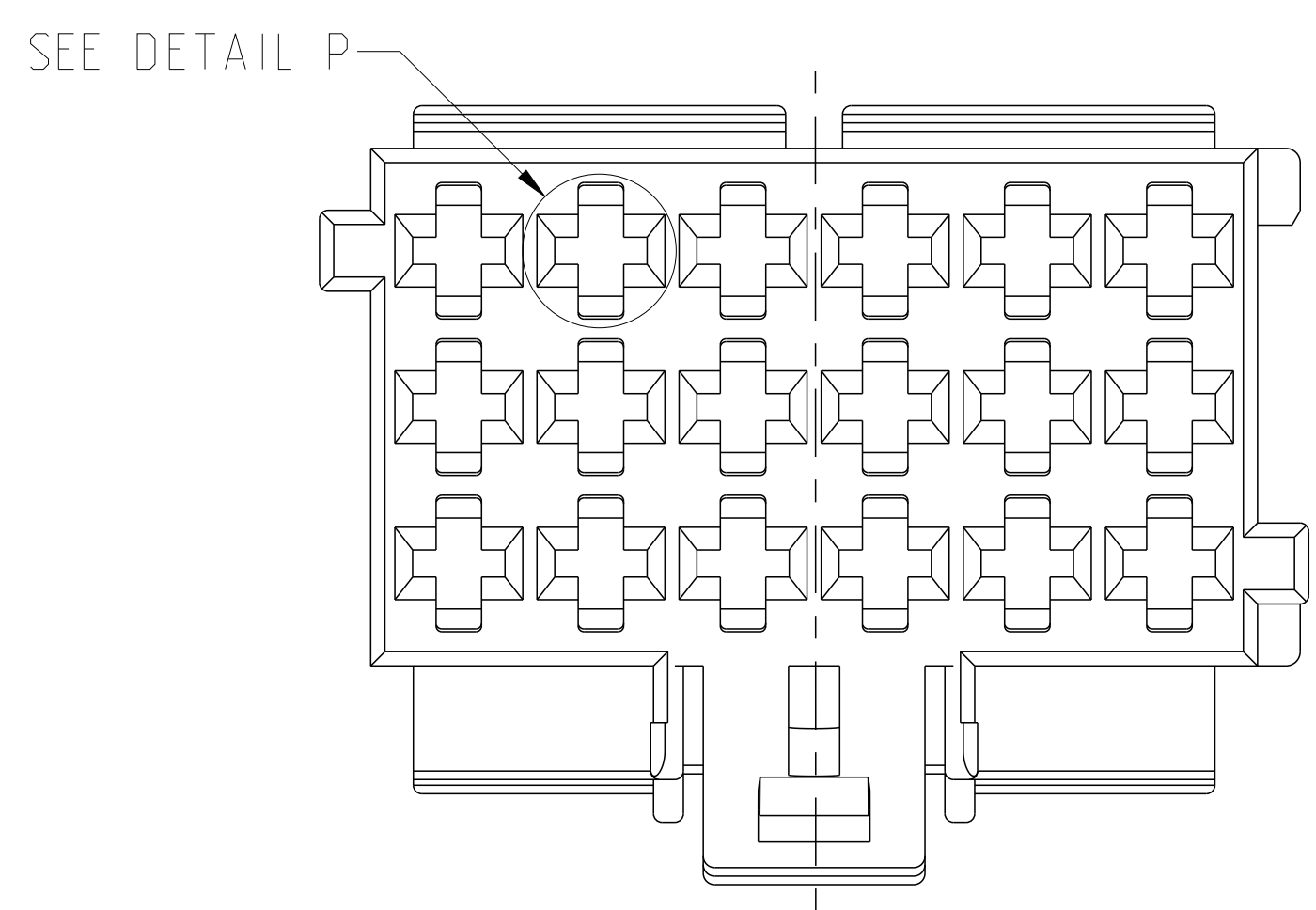
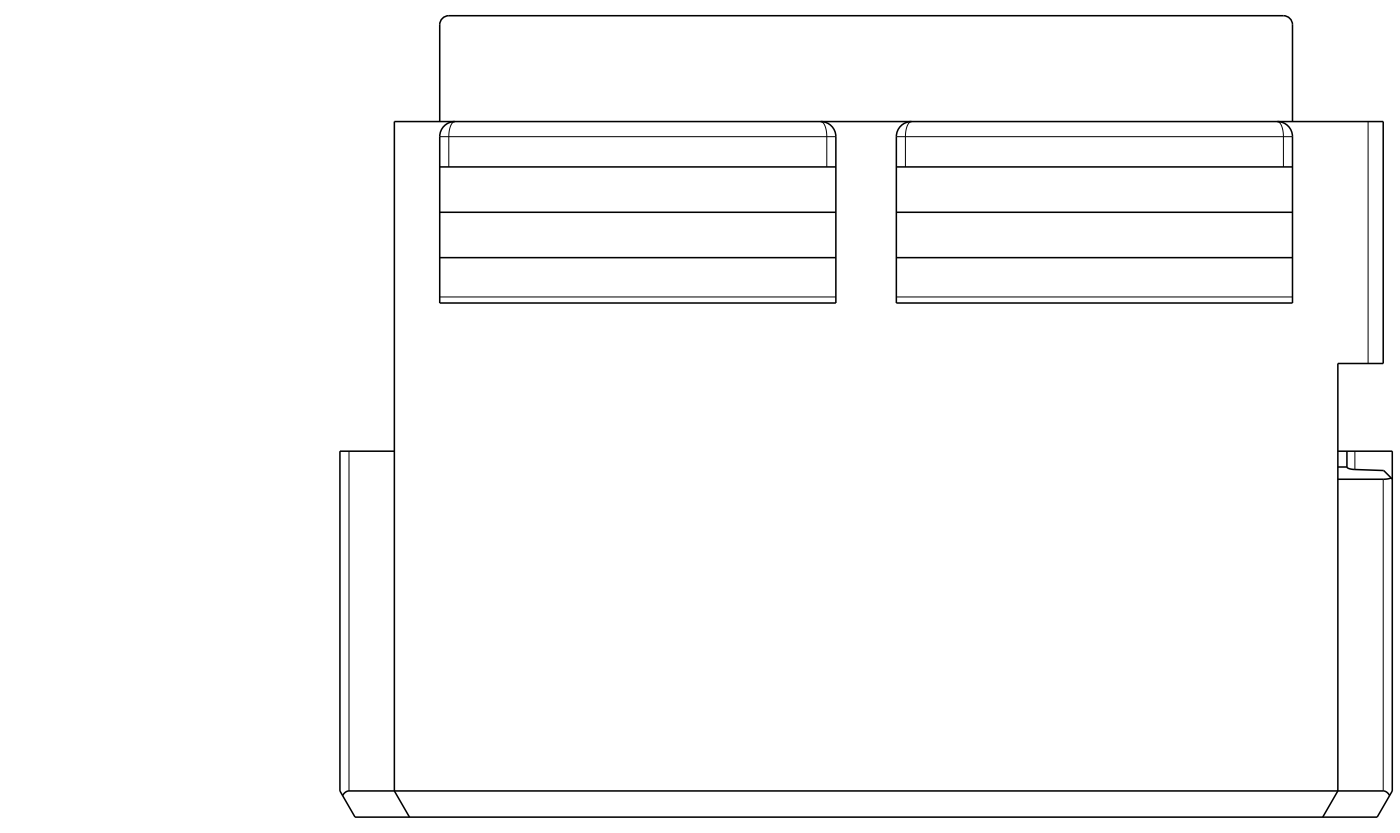
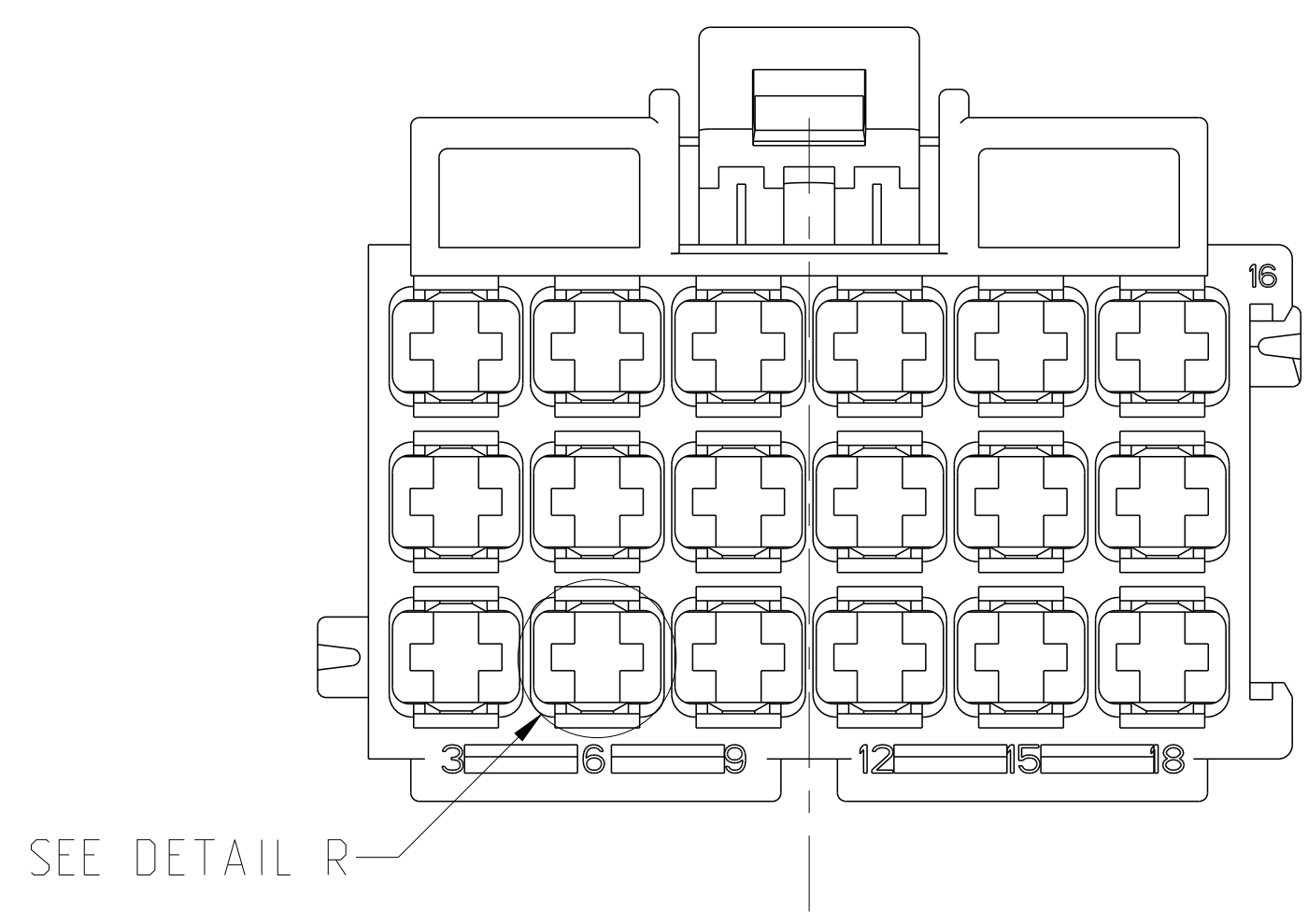

- NOTE:
- 1. TE LOGO.
  - 2. MAKING DATE.
  - 3. PART REVISION, ACTUAL STATUS ACC. TO TABLE
  - 4. MATERIAL-MAKING
  - 5. CAVITY MARK.
  - 6. TE PART NUMBER
  - 7. EXCHANGABLE
  - 8. BURRS PERMITTED ≤ 0.2MM
  - 9. GENERAL TOL: ± 0.2
  - 10. BURRS PERMITTED ≤ 0.5MM

REALIZED CODINGS:

BASIC CODING A = RIBS B-C

CODING B = RIBS A-C

CODING C = RIBS B-D

CODING D = RIBS C-E

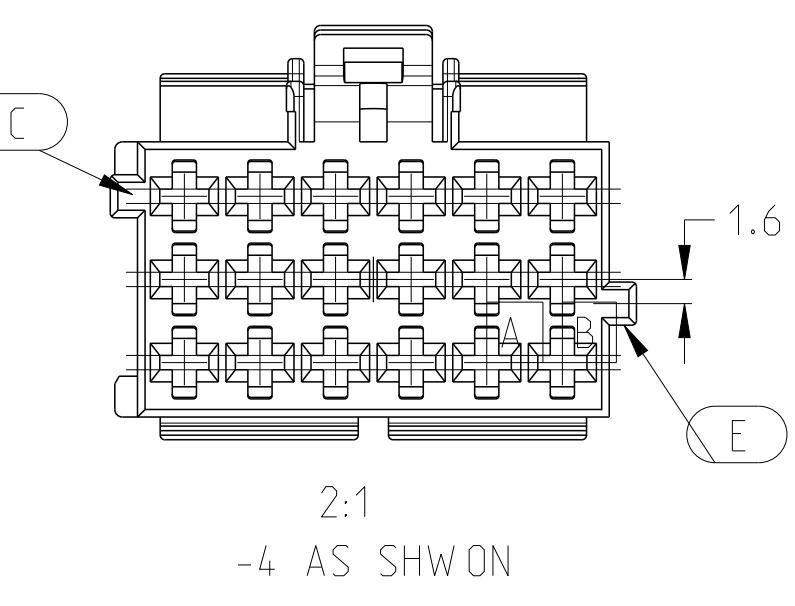
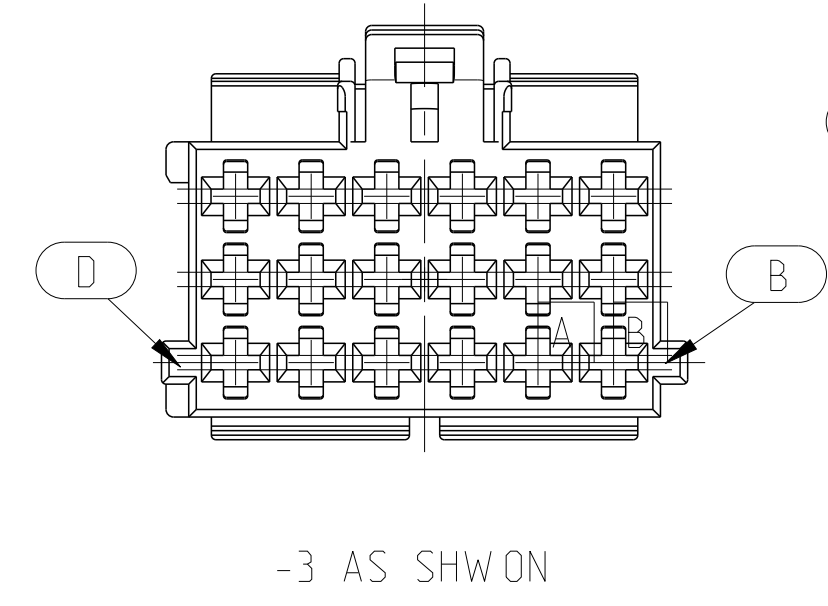
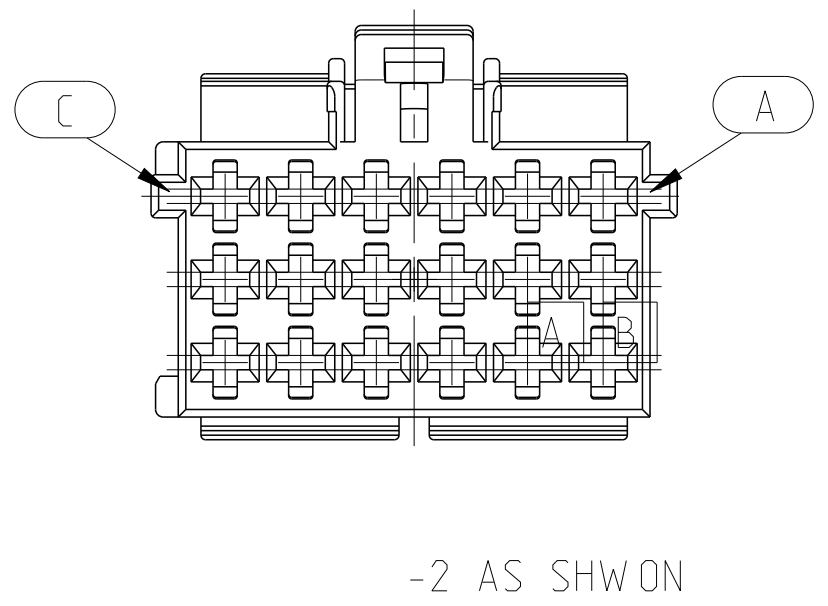
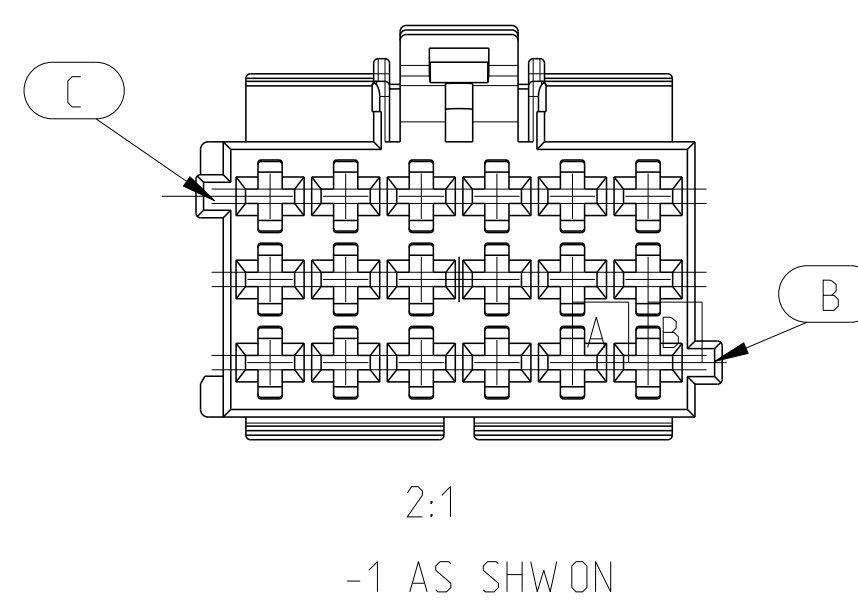

DESCRIPTION	COLOUR	WEIGHT	MATERIAL	TE P/N	PART REV	ITEM NO
MCP HOUSING, 18POS., CODING D	VIOLET	9.516g	PBT-GF15	-4	B	4
MCP HOUSING, 18POS., CODING C	BLUE	9.516g	PBT-GF15	-3	B	3
MCP HOUSING, 18POS., CODING B	NATURAL(WHITE)	9.516g	PBT-GF15	-2	B	2
MCP HOUSING, 18POS., CODING A	GREY	9.516g	PBT-GF15	-1	B	1

**PART LIST**

THIS DRAWING IS A CONTROLLED DOCUMENT.		OWN: H. XU	04/SEPT/2	TE Connectivity
DIMENSIONS: mm		CHK: Z. ZHOU	15/NOV/12	
TOLERANCES UNLESS OTHERWISE SPECIFIED:		APVD: W. YUAN	15/NOV/12	
1. PLC ±0.1 2. P.L.C ±0.1 3. P.L.C ±0.1 4. P.L.C ±0.1 ANGLES ±2°		NAME: AMP-MCP 2.8mm RECEPTACLE HOUSING .18POS	RESTRICTED TO	
MATERIAL: PBT-GF15 1573359-4	WEIGHT: 9.516g	SIZE: A1	CAGE CODE: 00779	DRAWING NO: ©=2137358
CUSTOMER DRAWING		SCALE: 4:1	SHEET: 2 OF 2	REV: B